

# /// /// /// /// /// /// /// /// **ZERO-MAX<sup>®</sup>**

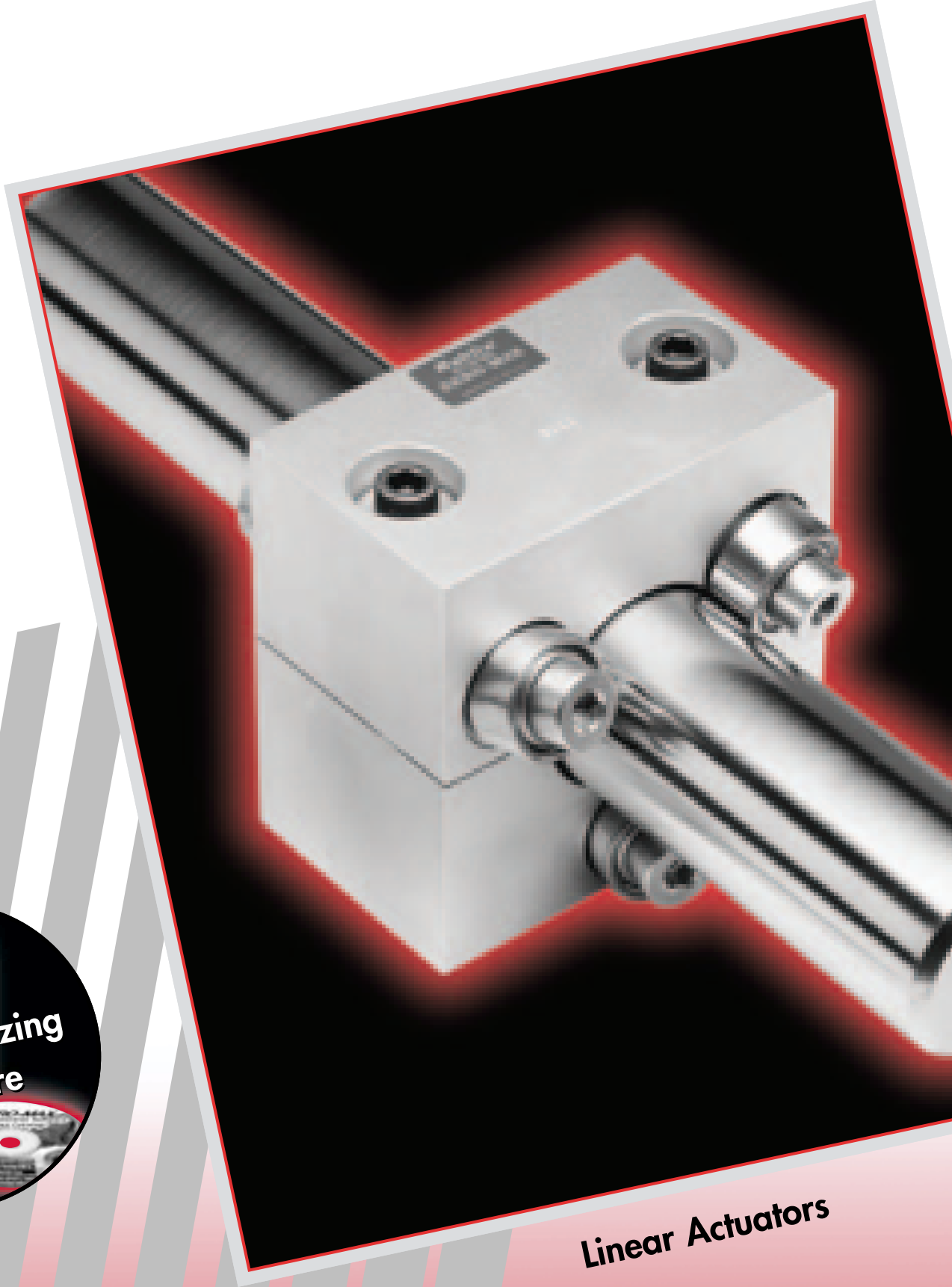

**Linear Actuators**



**INDUSTRIAL**  
**MAGZA**  
DIST. AUTORIZADO  
MEX (55) 53 63 23 31 MTY (81) 83 54 10 18  
QRO (442) 1 95 72 60 ventas@industrialmagza.com

**MAGZA**  
INDUSTRIAL  
DIST. AUTORIZADO  
MEX (55) 53 63 23 31 MTY (81) 83 54 10 18  
QRO (442) 1 95 72 60 ventas@industrialmagza.com

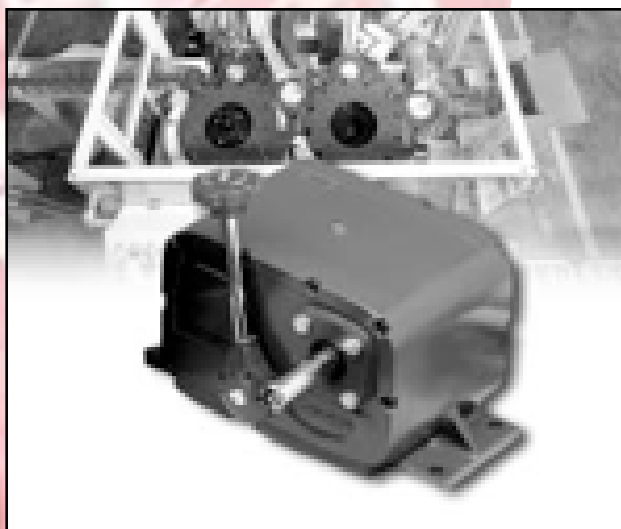

**Adjustable Speed Drives**

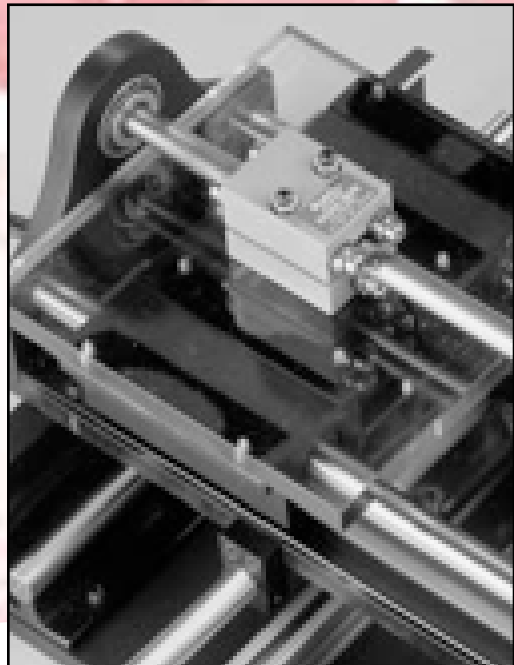

**Linear Actuators**

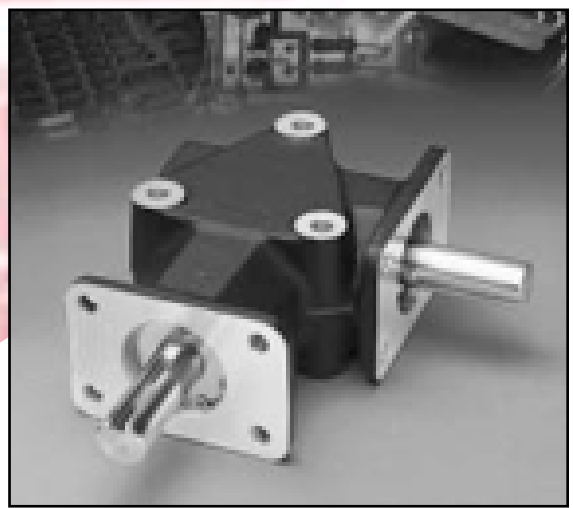

**Right Angle Gear Drives**

For nearly half a century, Zero-Max has supplied industries around the world with millions of adjustable speed drives, right angle gear drives and linear actuators in standard and custom designs. These products are designed to accurately assist in controlling demanding machine processes.

From precise adjustable speed drives used in agricultural equipment and conveyors, to right angle gear drives used in large printing presses, and linear actuators used in special machines to make styrofoam—there are Zero-Max products working dependably every second of every day.

Large and small companies in most manufacturing industries have learned to depend on and trust Zero-Max motion control products.

# Roh'lix® Linear Actuators

Designed to convert rotary motion into linear motion, Roh'lix Linear Actuators are ideal for positioning operations in all types of machinery. Available in 5 different sizes from 5 to 200 pounds thrust.

- Introduction . . . . . Page 6
- How They Work, Features/Benefits . . . . . 7
- Operating Characteristics . . . . . 8
- Life Expectancy/Installation . . . . . 9
- How To Select . . . . . 10-11
- Applications . . . . . 11

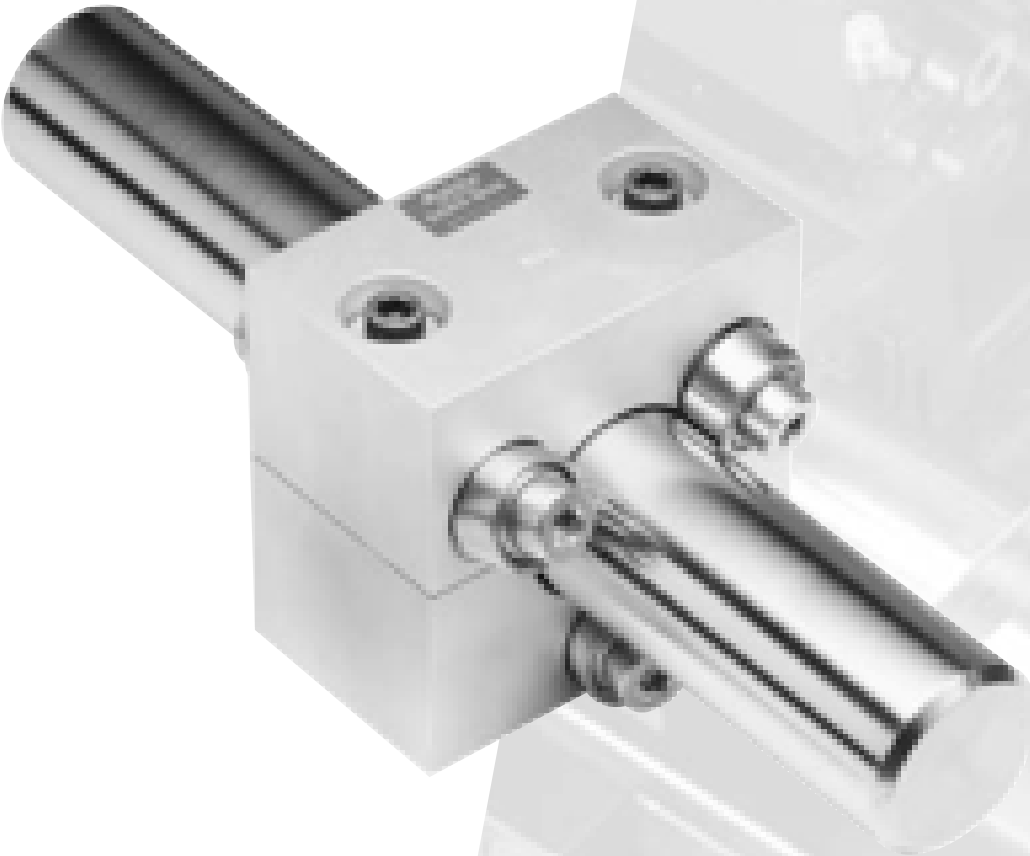

**INDUSTRIAL**  
**MAGZA**  
 DIST. AUTORIZADO  
 MEX (55) 53 63 23 31 MTY (81) 83 54 10 18  
 QRO (442) 1 95 72 60 ventas@industrialmagza.com

# Thousands of Quality Zero-Max Products Are Used Every Second, Every Day, Somewhere In The World

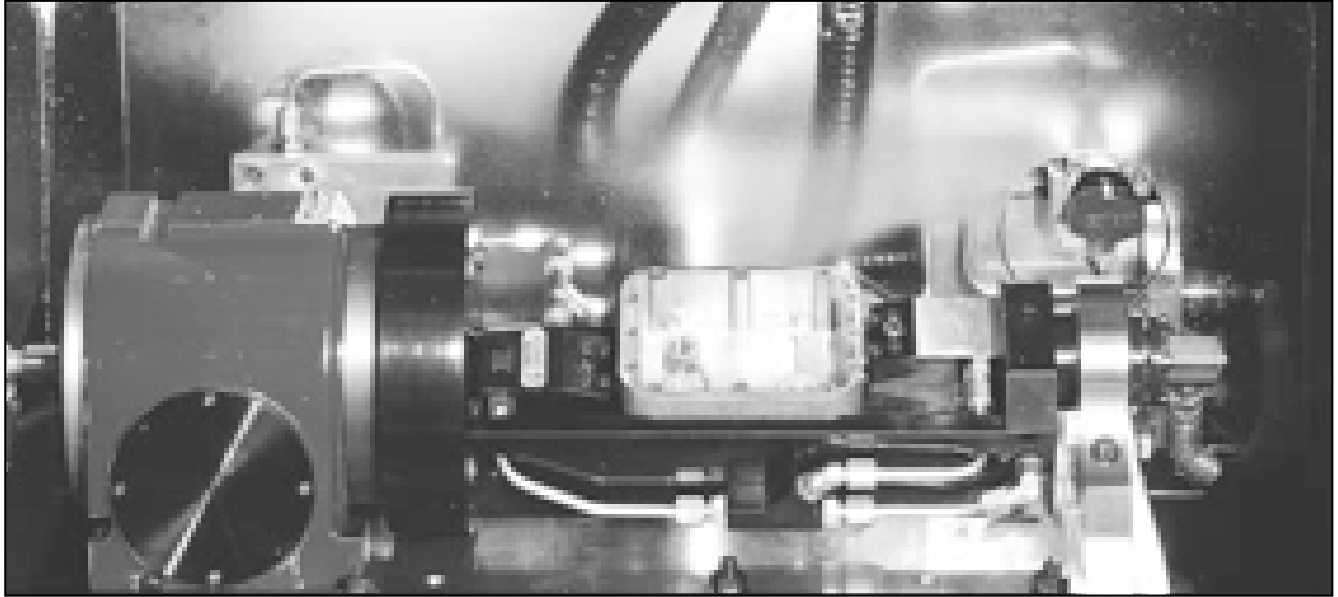

**INDUSTRIAL**  
**MAGZA**  
DIST. AUTORIZADO  
MEX (55) 53 63 23 31  
QRO (442) 1 95 72 60  
MTY (81) 83 54 10 18  
ventas@industrialmagza.com

### **Zero-Max® Adjustable Speed Drives**

are manufactured and assembled in our Plymouth, MN. U.S.A. facility. All components are thoroughly inspected prior to assembly. After assembly, each unit is “run-in” for at least four hours to assure consistent quality from unit to unit.

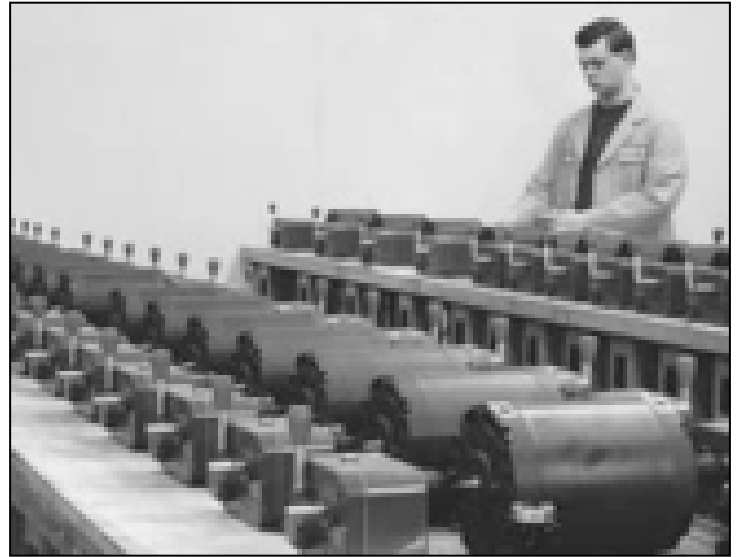

### **Crown Right Angle Gear Drives**

set the standard for 1:1 and 2:1 spiral bevel gear drives. Every component is precision machined, inspected and then carefully assembled. Crown Gear Drives are quiet in operation due to the special care taken in manufacturing and assembly.



### **Roh'lix® Linear Actuators**

are manufactured within tight tolerances to provide accurate linear travel with each shaft revolution. The Roh'lix principle allows the unit to slip when the thrust capacity is exceeded, thereby offering protection to other components in the power train.



## Roh'lix® Linear Actuators

The Roh'lix Linear Actuator is a device that converts rotary motion into linear motion. The Roh'lix uses **rolling** element ball bearings that trace a **helix** pattern along the shaft, which produces a Rolling Helix, or **Roh'lix** for short. Available sizes have thrust capacities ranging from 15 to 200 lbs (67 to 889 Newtons), shaft diameters ranging from 3/8 to 2.00 inches (8 to 50 mm), and leads ranging from 0.025 to 6.00 inches (0.625 to 150 mm).

The Roh'lix Linear Actuator consists of six preloaded bearings that contact the shaft at an angle. When the shaft is rotated, the bearings trace out an imaginary screw thread, causing the Roh'lix to travel linearly along the shaft.

The thrust of the Roh'lix is established by spring force between the two block halves. The thrust force

is adjusted by the thrust adjustment screws on the top of the block, allowing the thrust setting to be fine-tuned to individual applications. When the thrust setting is exceeded, the Roh'lix slips on the shaft until the source of the overload is corrected. The ability to slip allows the Roh'lix to provide overload protection for the equipment on which it is used.

The amount of linear distance the Roh'lix travels per shaft revolution is called lead. The lead is determined by the angle of the bearings in the Roh'lix block. The Roh'lix can be manufactured with virtually any fixed lead up to 3 times the shaft diameter. The lead, in combination with the driveshaft speed, determines the linear travel rate. By changing either the lead or the driveshaft speed, you can change the rate of linear travel.



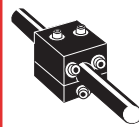

# How Roh'lix® Linear Actuators Work

Roh'lix Actuators have six precision ball bearings, three at each end of a two-piece aluminum block.

Mounted at an angle relative to the drive shaft axis, the bearings convert drive shaft rotation into proportional linear travel. This is called lead. The linear thrust capability of the Roh'lix is determined by the friction between

the smooth surfaces of the angled bearings and the drive shaft.

Thrust capability is varied by adjusting the cap screws located on the top of the load block.

Loads exceeding the thrust setting cause the Roh'lix to stop while the bearings rotate in place as long as the drive shaft is turning.



## Check These Roh'lix® Actuator Advantages

Features	Benefits
5 different sizes, wide range of leads, various shaft diameters available.	Many units to choose from to get the right one for your application.
2-piece, split aluminum block.	Easy installation; the block halves can be assembled around the shaft without necessitating the removal of driveshaft and/or pillow-block bearings.
Overload protection.	Roh'lix has the ability to slip in the event of a jam-up, protecting product equipment.
Adjustable thrust setting.	Thrust can be set precisely to carry the load without slipping, but not so high that the Roh'lix builds up unnecessary thrust before overloading.
Six ball bearings	High efficiency – exceeding 90%. Long life; ranging from 2 million to 100 million inches of linear travel.
Coil springs for thrust adjustment.	Preloads bearings to minimize backlash to less than 0.001 inch. Minimal backlash stays consistent throughout the lifetime of the unit.
Socket-head shoulder screws to mount the bearings to the block.	Allows for easy bearing replacement.

# Roh'lix® Operating Characteristics

## Efficiency

The rolling contact between the outer races of the six ball bearings and the driveshaft provides a smooth, quiet linear motion, resulting in a minimum of 90% efficiency.

## Backlash

Roh'lix bearings are preloaded by the coil springs to reduce backlash to less than 0.001 inch, which help maintain consistency throughout the life of the bearings.

## Positioning Accuracy

The Roh'lix is a friction drive device and as a result, will show an accumulated error that is, in general, up to 0.002 inches per shaft revolution. Where greater accuracy is required, linear encoders can be used to indicate position.

## Overload Protection

The Roh'lix has the ability to slip if an obstruction is encountered in the system. This unique advantage over other types of linear actuators can prevent damage and costly downtime.

## Lubrication

Roh'lix bearings are factory-lubricated for life and are designed to run on a clean, non-lubricated driveshaft.

## Shafting

Recommended driveshaft material is C-1060 hardened and ground shafting with a minimum hardness of HRC 58. Its hardness will provide optimum life expectancy and its ground surface provides a uniform friction surface. Stainless steel shafting, although slightly softer, is adequate for many applications requiring corrosion protection.

## Temperature

Acceptable temperature range is -10°F to +180°F. Special units available for higher or lower temperatures.

## Maintenance

Unit is maintenance free, however, the shafting may require occasional wiping to clean off foreign matter that may accumulate.

## Backdriving

By applying a thrust load to the Roh'lix unit, the shaft can be made to rotate. The thrust load will cause the Roh'lix and any device attached to it to travel along the shaft. Therefore, the Roh'lix should never be relied upon as the sole device to hold position.

## Tandem Roh'lix

Two Roh'lix may be used on a common shaft in series, or in parallel on separate shafts, however, the combined thrust rating must be derated by 20%. When installing the Roh'lix units, be sure to tighten the thrust adjustment screws an equal number of turns so that they share the thrust load equally.

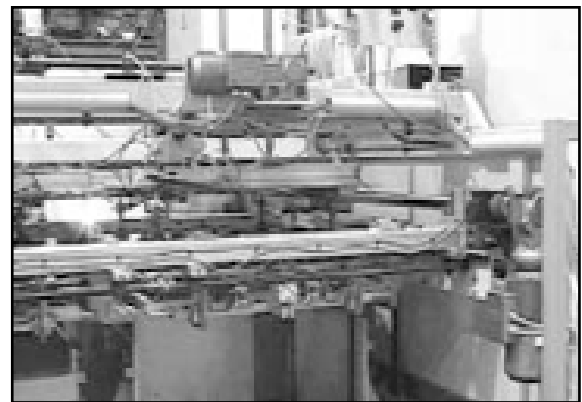
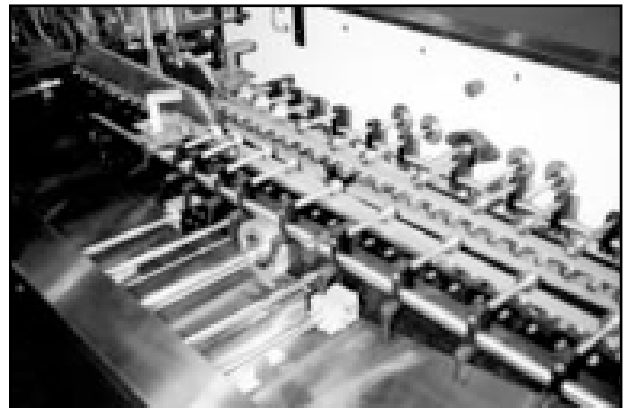



# Roh'lix® Operating Characteristics

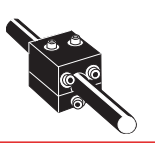

## Roh'lix Life Expectancy

Roh'lix lifetime can range anywhere from 2 million to over 100 million inches of linear travel, depending on the application variables. The following factors should be considered to maximize the lifetime of Roh'lix:

**Thrust:** Roh'lix lifetime is increased when the application thrust load is a smaller percentage of the unit's thrust rating. Selecting an oversized Roh'lix is advisable to achieve the greatest lifetime of the unit.

**Lead/Shaft Speed:** Higher lead units will produce longer lifetime because fewer bearing revolutions will be required to move the same linear distance as a low lead unit. Also, reductions in the driveshaft RPM will increase lifetime. For a given linear speed, a higher lead will allow a lower shaft speed, and the two factors in combination will work to yield a greater lifetime.

**Overloading:** Occasional slippage for short periods of time is acceptable. However, frequent or extended periods of slippage will result in reduced lifetime of the bearings.

**Other:** Minimize sideloads and twisting loads to gain maximum life from the Roh'lix.

## Loading

The Roh'lix is intended for axial loading. Sideloads and twisting loads (**Figure 1**) should be avoided whenever possible, as they cause uneven bearing loading and shorten lifetime.

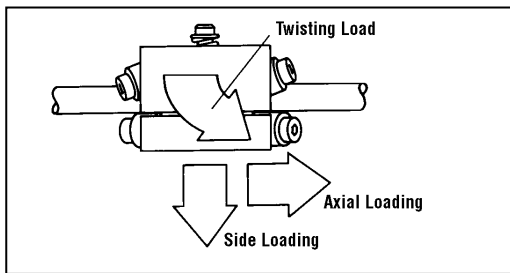

**Figure 1**

Whenever possible, the load weight on the Roh'lix should be supported by a separate linear bearing assembly. Where sideloads cannot be avoided, the amount of the sideload should be subtracted from the thrust capacity of the unit. The amount of the sideload should never exceed 50% of the actuator's thrust capacity. If necessary, select an oversized Roh'lix to handle these application conditions.

## Installation

The Roh'lix has a split-block for ease of installation. The two block halves can be assembled around the shaft, eliminating the need for removal of pillow-block bearings, coupling, etc. The split-block design is also a benefit for removal of the Roh'lix for service, such as bearing replacement.

## Thrust Adjustment

Thrust of the Roh'lix is set by one of three methods:

- 1) Adjust the thrust adjustment screws in increasing amounts until thrust setting is enough to carry load without slipping. This allows slippage before an overload builds up an unnecessary thrust load causing reduced bearing life.
- 2) Use a spring scale to set the amount of thrust (**Figure 1**). This technique works where the thrust requirement is known.
- 3) Use the thrust per turn rating (**Figure 2**) to determine the appropriate number of turns of the thrust adjustment screws. This technique also works where the thrust requirement is known.

Model #	Screw Length	Screw Size	Thrust per Turn
1	1.25	6-32	3 lbs.
2	1.50	10-32	17 lbs.
3	2.00	1/4-20	25 lbs.
4	2.25	1/4-20	25 lbs.
5	2.50	3/8-16	35 lbs.

**Figure 2**

To set a given thrust on the Roh'lix, start with the thrust adjustment screws loose then tighten by hand until the screw head lightly touches the top of the spring. Tighten both adjusting screws one full turn. This will set the thrust as shown in the thrust column of **Figure 2**. Finish the thrust adjustment by turning the additional turns as necessary.

**Magza Industrial**  
 MEX (55) 53 63 23 31  
 QRO (442) 1 95 72 60  
 MTY (81) 83 54 10 18  
 ventas@industrialmagza.com  
 DIST. AUTORIZADO

# How To Select A Roh'lix® Linear Actuator

## 1. Determine Thrust Requirement.

Horizontal Applications:  $F = \mu W$

Vertical Applications:  $F = W + \mu W$

$F$  = thrust requirement (Lbs.)

$\mu$  = Coefficient of friction

$W$  = weight of load being moved (Lbs.)

## 2. Determine Lead/ Driveshaft Speed/ Linear Speed.

$$\text{Driveshaft RPM} = \frac{60 \times \text{Linear Speed}}{\text{Roh'lix Lead}}$$

**Driveshaft RPM** = speed of shaft driving the Roh'lix (RPM)

**Linear Speed** = travel rate of the Roh'lix (inches per sec.)

**Roh'lix Lead** = lead of the Roh'lix (inches per shaft revolution)

## 3. Select Roh'lix Model.

Choose a Roh'lix Model from **Figure 2a** or **2b** that has a thrust equal to or exceeding the thrust requirement determined in **Step 1** and lead that fits the driveshaft RPM and linear speed needs from **Step 2**.

## 4. Verify Shaft Diameter.

Driveshaft speed should be within the maximum recommended driveshaft speed shown in **Figure 3**.

If driveshaft speed is above the recommended speed, try changing one or more of the following:

- 1) Change the bearing mounted method to B or C to increase the maximum recommended driveshaft speed above the application requirement, or
- 2) Change to hollow shafting, which will increase the maximum recommended speed by approximately 50% above ratings shown in **Figure 3**, or
- 3) Select a higher lead Roh'lix to reduce the shaft speed requirement, yet still maintain the desired linear travel rate.

### Inch Models

Size	Model Number	Shaft dia. (In)	Lead (In)	Thrust Rating (Lb)
1	1104	3/8	.03	15
	1111	3/8	.10	15
2	2102	3/8	.10	30
	2114	3/8	.20	30
	2103	3/8	.50	30
	2101	1/2	.10	30
	2115	1/2	.20	30
	2104	1/2	.50	30
	2112	1/2	1.00	30
	3123	1/2	.20	60
3	3109	1/2	.50	60
	3128	1/2	1.00	60
	3110	5/8	.10	60
	3145	5/8	.50	60
	3103	3/4	.10	60
	3107	3/4	.75	60
	3133	3/4	1.00	60
	4118	1	.20	100
4	4110	1	.50	100
	4111	1	1.00	100
	4125	1	2.00	100
	5106	1-1/2	1.00	200
5	5109	2	.38	200
	5112	2	3.00	200

Figure 2a

### Metric Models

Size	Model Number	Shaft dia.	Lead (mm)	Thrust Rating (newton)
1	1901	8	1.3	67
	1902	8	2.5	67
2	2901	8	2.5	133
	2902	8	15.0	133
	2903	12	5.0	133
	2904	12	15.0	133
	2905	12	25.0	133
	3901	12	2.5	266
3	3902	12	10.0	266
	3913	16	2.5	266
	3914	16	15.0	266
	3915	16	25.0	266
4	4901	25	2.5	444
	4902	25	5.0	444
	4903	25	25.0	444
5	5901	40	10.0	889
	5902	50	5.0	889
	5903	50	50.0	889

Leads are available from a minimum of 0.025 inch (.625mm) to maximum of 3 times the shaft diameter. Drive shaft diameters may be as small as 3/8 inch to as large as 2 inches. (8 to 50 mm)

Figure 2b

### Special Models

Stainless steel hardware and bearings may be supplied along with a clear chromated block for use in corrosive atmospheres in sizes 1 through 4, however thrust rating must be derated by 25%.

Anodized or stainless steel blocks are not available.

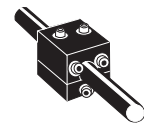

# How To Select A Roh'lix® Linear Actuator

## Maximum Recommended Drive Shaft Speed

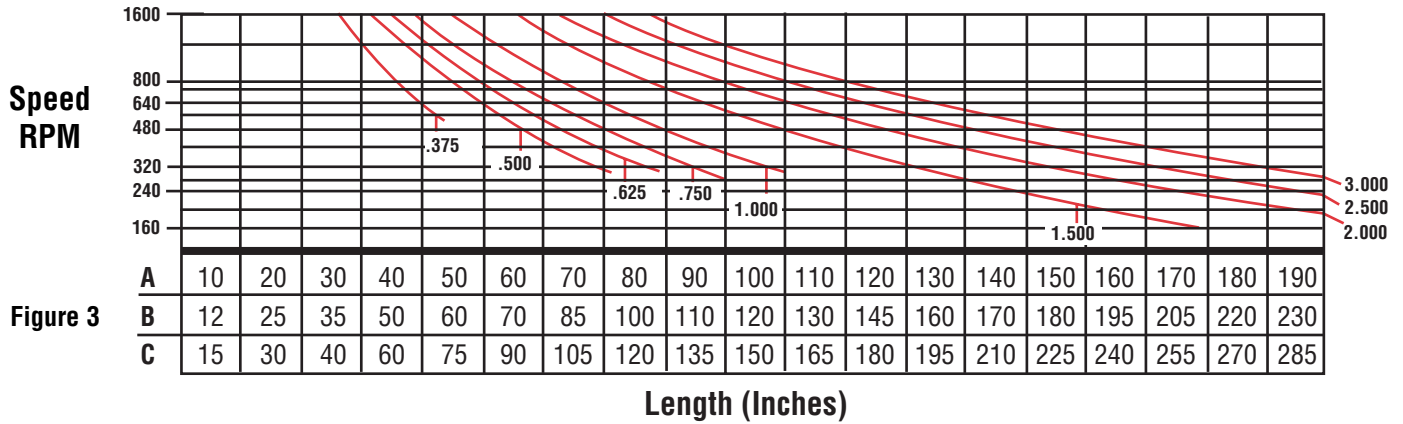

## Bearing Mounting Method

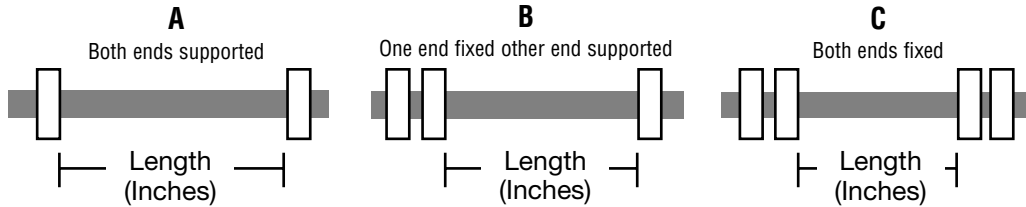

### Roh'lix Sizes 1-5

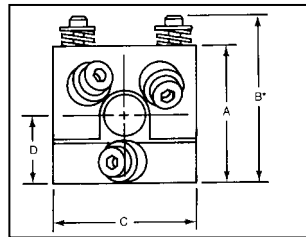
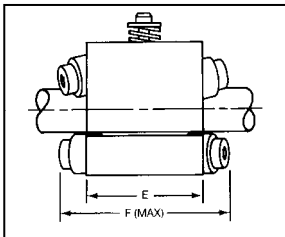

### Roh'lix Sizes 1-3

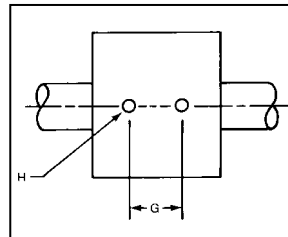

### Roh'lix Sizes 4-5

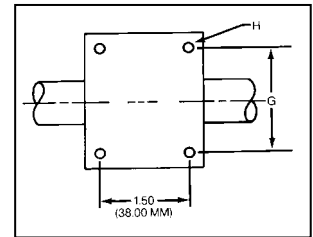

Size	Dimensions							H-Tapped Mounting Holes
	A	B	C	D	E	F	G	
1	1.14	1.66	1.12	.57	1.62	2.25	.75	#6-32 UNC x 1/4 DP
	(29)	(42.2)	(28.6)	(14.5)	(41.3)	(57.2)	(19)	(M3 x 0.5 x 6.35 DP)
2	1.52	1.91	1.50	.76	2.00	2.81	1.00	#10-32 UNF x 3/8 DP
	(38.6)	(48.5)	(38.1)	(19.3)	(50.8)	(71.4)	(25.4)	(M5 x 0.08 x 9.53)
3	2.02	2.69	2.00	1.01	2.50	3.42	1.25	1/4-20 UNC x 1/2 DP
	(51.3)	(68.3)	(50.8)	(25.6)	(63.5)	(86.9)	(31.1)	(M6 x 1.0 x 12.7 DP)
4	3.00	3.50	3.00	1.50	2.50	3.56	2.50	1/4-20 UNC x 1/2 DP
	(76.2)	(88.9)	(76.2)	(38.1)	(63.5)	(90.4)	(63.5)	(M6 x 1.0 x 12.7 DP)
5	4.50	4.68	4.50	2.25	2.75	4.68	4.00	1/4-20 UNC x 1/2DP
	(114.3)	(118.9)	(114.3)	(57.2)	(69.9)	(118.9)	(101.6)	(M6 x 1.0 x 12.7 DP)

Dimension at Zero Thrust Setting. Dimensions in ( ) are for metric models.

### Typical Roh'lix Applications Include:

Core Cutter, Door Opener, CNC Lathe Feeder, Paint Sprayer, Adjustable Web Guides, Microfiche File, X-Y Positioning Table, Height Gauge, Optical Measuring Scanner, Inspection Table, Parts Feeder, Pick and Place Machine, Screen Printer, Robotic Gantry, Ink Agitator, Transfer Table, and Back Gauge.

