

# /// /// /// /// /// /// /// /// /// **ZERO-MAX<sup>®</sup>**

**INDUSTRIAL MAGAZA<sup>®</sup>**  
DIST. AUTORIZADO  
MEX (55) 53 63 23 31 MTY (81) 83 54 10 18  
QRO (442) 1 95 72 60 ventas@industrialmagza.com



**QD Hub Style CD<sup>®</sup> Couplings**  
High Misalignment And High Torsional Stiffness

# QD Hub Style CD<sup>®</sup> Couplings

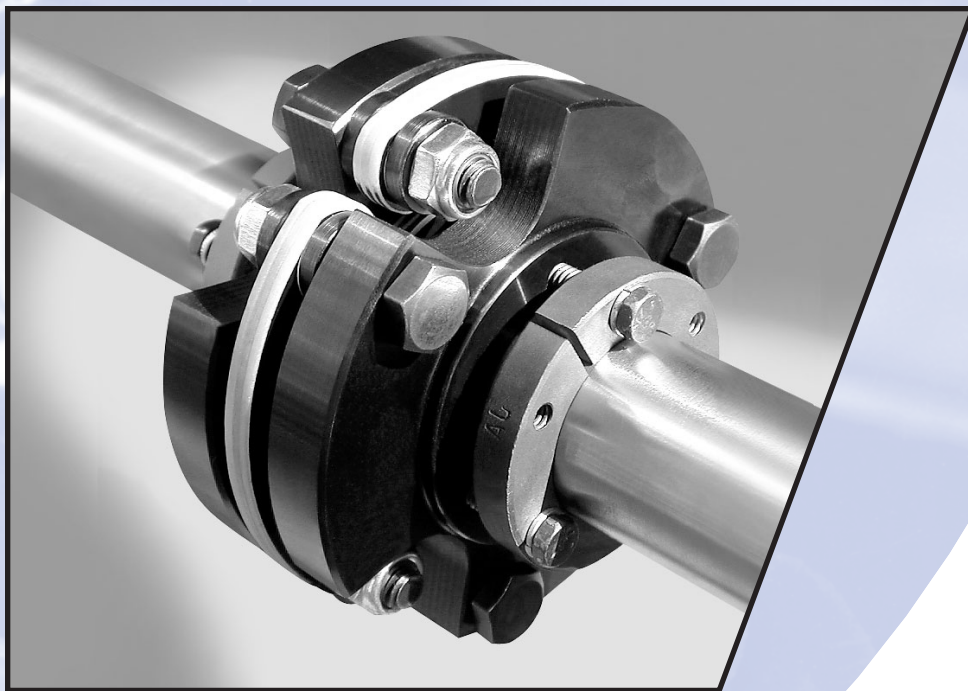

## QD Bushing Hub Couplings

Single disc coupling has machined hub to accept standard QD bushing.

*The new Zero-Max CD coupling with QD bushing hubs is available in both Single Flex and Double Flex models. The Single Flex model provides misalignment up to 3° angular, 0.025" parallel and 0.160" axial. The Double Flex model provides misalignment up to 3° angular, 0.089" parallel and 0.32" axial, with up to 16,000 in lbs of torque capacity for either model. Both models are available with steel hubs to accept QD bushings in inch or metric bore sizes. These CD couplings with QD bushing hubs are available in sizes 37 to 77 and are available in stock for immediate shipment from Zero-Max. The QD bushings can be purchased directly from most local distributors.*

Zero-Max CD<sup>®</sup> Couplings which combine the best features of both steel disc and elastomeric couplings are now available with QD bushing hubs. Fast and easy to install, these standard CD Couplings with the QD hubs are designed to accommodate a large range of QD bushing bore sizes. The QD bushings are available from your local distributor in either metric or inch bores.

Considered to be industry's most unique coupling innovation of the last decade, the patented CD<sup>®</sup> Coupling features a unique open arm disc pack design made of rugged composite material. The design provides the high misalignment capacity of elastomeric couplings but with higher torsional stiffness.

The Zero-Max CD<sup>®</sup> Coupling also has higher misalignment capacity compared to steel disc couplings. It provides superior damping and isolation of shock and vibrating loads. It eliminates fretting corrosion and results in a dramatic reduction of stress fractures at the bolt hole locations, a common problem with conventional steel disc couplings.

The CD<sup>®</sup> Coupling also has excellent chemical and moisture resistance in hostile environments, conditions which are too difficult or impossible for steel disc and elastomeric couplings.

# Single Flex Series 6A

## -Coupling Dimension Information

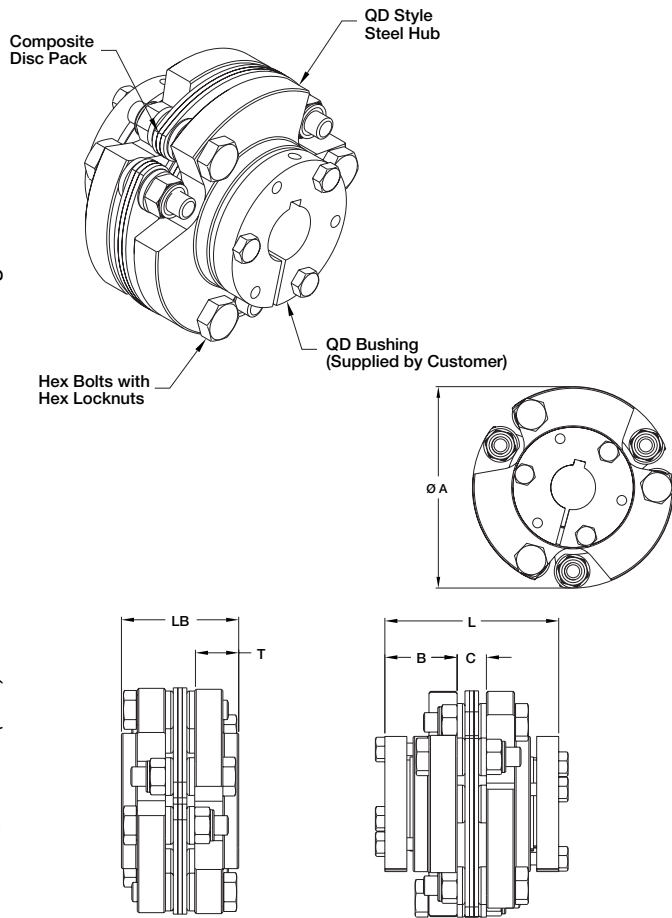

Bushing Model*	A	B	C	T	L	LB	
							Inch (mm)
6A37QD	JA	3.75 (95.3)	1.13 (28.6)	0.52 (13.3)	0.63 (16.0)	2.77 (70)	1.78 (45.2)
6A45QD	SH	4.50 (114)	1.44 (36.6)	0.58 (14.8)	0.88 (22.4)	3.46 (88)	2.34 (59.5)
6A52QD	SD	5.25 (133)	2.00 (50.8)	0.65 (16.4)	1.38 (35.1)	4.65 (118)	3.41 (87)
6A60QD	SD	6.00 (152)	2.00 (50.8)	0.77 (19.5)	1.38 (35.1)	4.77 (121)	3.53 (90)
6A67QD	SK	6.75 (172)	2.07 (52.6)	0.86 (21.8)	1.38 (35.1)	4.99 (127)	3.62 (92)
6A77QD	SF	7.75 (197)	2.19 (55.6)	1.01 (25.7)	1.50 (38.1)	5.39 (137)	4.01 (102)

## -Coupling Performance Information

Max HP/100 RPM	Continuous* Rated Torque	Torsional Stiffness	Maximum Misalignment			Unit Weight (w/Bushing)
			Angular	Parallel	Axial	
In lb (Nm)	In lb (Nm)	In Lbs/deg (Nm/Rad)	Degrees	Inch (mm)	Inch (mm)	Lb (Kg)
2.54	1,600 (181)	10,374 (67,167)	3	0.013 (0.3)	0.070 (1.8)	3.7 (1.7)
3.97	2,500 (282)	19,138 (123,909)	3	0.015 (0.4)	0.090 (2.3)	6.8 (3.1)
5.65	3,560 (402)	26,049 (168,656)	3	0.018 (0.5)	0.110 (2.8)	11.7 (5.3)
10.08	6,350 (718)	41,485 (268,595)	3	0.020 (0.5)	0.130 (3.3)	15.8 (7.2)
16.34	10,300 (1,164)	61,948 (401,084)	3	0.022 (0.6)	0.150 (3.8)	20.5 (9.3)
24.75	15,600 (1,763)	94,107 (609,303)	3	0.025 (0.6)	0.160 (4.1)	29.5 (13.4)

\*Peak torque of CD Coupling is two times the continuous torque rating. Apply proper service factor (See p 4).

# Double Flex Series 6P

## -Coupling Dimension Information

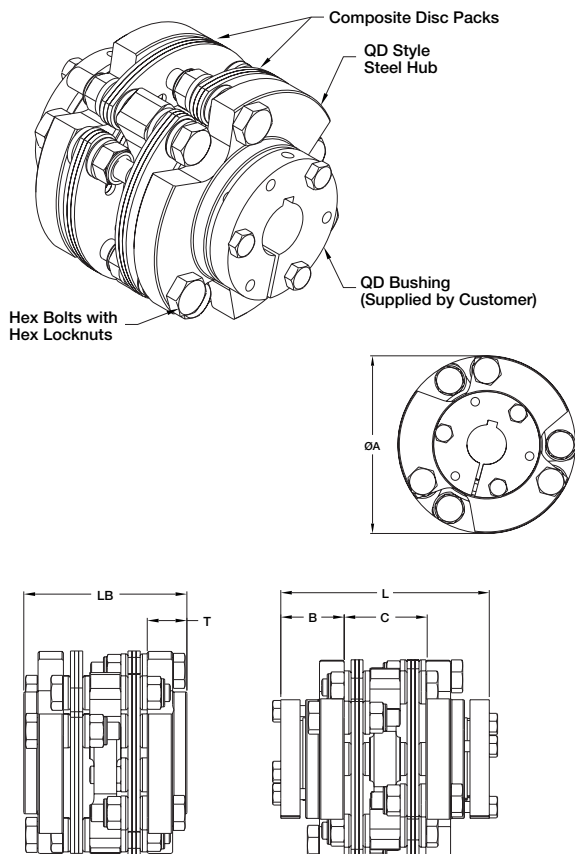

Bushing Model*	A	B	C	T	L	LB	
							Inch (mm)
6P37QD	JA	3.75 (95.3)	1.13 (28.6)	1.67 (42.4)	0.63 (16.0)	3.93 (99.6)	2.93 (75)
6P45QD	SH	4.50 (114)	1.44 (36.6)	1.85 (47.0)	0.88 (22.4)	4.73 (120)	3.61 (92)
6P52QD	SD	5.25 (133)	2.00 (50.8)	2.11 (53.5)	1.38 (35.1)	6.11 (155)	4.87 (124)
6P60QD	SD	6.00 (152)	2.00 (50.8)	2.41 (61.2)	1.38 (35.1)	6.41 (163)	5.17 (131)
6P67QD	SK	6.75 (172)	2.07 (52.6)	2.70 (68.7)	1.38 (35.1)	6.84 (174)	5.46 (139)
6P77QD	SF	7.75 (197)	2.19 (55.6)	3.15 (80.1)	1.50 (38.1)	7.53 (191)	6.15 (156)

## -Coupling Performance Information

Max HP/100 RPM	Continuous* Rated Torque	Torsional Stiffness	Maximum Misalignment			Unit Weight (w/bushing)
			Angular	Parallel	Axial	
In lb (Nm)	In lb (Nm)	In Lbs/deg (Nm/Rad)	Degrees	Inch (mm)	Inch (mm)	Lb (Kg)
2.54	1,600 (181)	5,051 (32,700)	3	0.049 (1.2)	0.140 (3.6)	4.0 (1.8)
3.97	2,500 (282)	9,317 (60,324)	3	0.052 (1.3)	0.180 (4.6)	8.1 (3.7)
5.65	3,560 (402)	12,682 (82,109)	3	0.062 (1.6)	0.220 (5.6)	13.9 (6.3)
10.08	6,350 (718)	20,196 (130,763)	3	0.069 (1.8)	0.260 (6.6)	18.9 (8.6)
16.34	10,300 (1,164)	30,159 (195,265)	3	0.076 (1.9)	0.300 (7.6)	24.7 (11.2)
24.75	15,600 (1,763)	45,815 (296,634)	3	0.089 (2.3)	0.320 (8.1)	36.8 (16.7)

\*Peak torque of CD Coupling is two times the continuous torque rating. Apply proper service factor (See p 4).

# QD Hub Style CD® Couplings

## Service Factor Guide

Load	Driving Equipment	
	Motor or Turbine	Reciprocating Engine
Uniform	1	1.5
Light Shock	1.5	2
Medium Shock	2	2.5
Heavy Shock	2.5	3

## How To Order

- Determine the complete model code and the bore size for coupling only, see example.

**Example** 6P45QD \*

<b>6</b>	<b>P</b>	<b>45</b>	<b>QD</b> *
<b>Configuration</b>		<b>Size</b>	
A = Single Flex		37	
P = Double Flex		45	
		52	
		60	
		67	
		77	

\*QD Bushings supplied by customer.

## Sizing software for CD Couplings

Zero-Max provides free software on a CD ROM to help select and size the correct CD Coupling. This CD ROM contains all Zero-Max product catalogs in a PDF format, a comprehensive sizing and selection program and CAD drawings for most of the Zero-Max products.



Visit the Zero-Max website for additional technical information at [www.zero-max.com](http://www.zero-max.com)

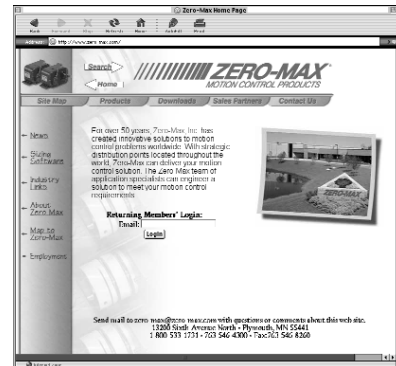

## WARRANTY

Zero-Max, Inc. the manufacturer, warrants that for a period of 12 months from date of shipment it will repair, or at its option, replace any new apparatus which proves defective in material or workmanship, or which does not conform to applicable drawings and specifications approved by the manufacturer. All repairs and replacements shall be F.O.B. factory. All claims must be made in writing to the manufacturer.

In no event and under no circumstances shall manufacturer be liable for (a) damages in shipment; (b) failures or damages due to misuse, abuse, improper installation or abnormal conditions of temperature, dirt, water or corrosives; (c) failures due to operation, intentional or otherwise, above rated capacities, and (d) non-authorized expenses for removal, inspection, transportation, repair or rework. Nor shall manufacturer ever be liable for consequential and incidental damages, or in any amount greater than the purchase price of the apparatus.

Zero Max, Inc. reserves the right to discontinue models or to change specifications at any time without notice. No discontinuance or change shall create any liability on the part of Zero-Max, Inc. in respect to its products in the hands of customers or products on order not incorporating such changes even though delivered after any such change.

This warranty is in LIEU OF ALL OTHER WARRANTIES, EXPRESS OR IMPLIED, INCLUDING (BUT NOT LIMITED TO) ANY IMPLIED WARRANTIES OF MERCHANTABILITY OR FITNESS FOR A PARTICULAR PURPOSE. THE TERMS OF THIS WARRANTY CONSTITUTE ALL BUYER'S OR USER'S SOLE AND EXCLUSIVE REMEDY, AND ARE IN LIEU OF ANY RIGHT TO RECOVER FOR NEGLIGENCE, BREACH OF WARRANTY, STRICT TORT LIABILITY OR UPON ANY OTHER THEORY. Any legal proceedings arising out of the sale or use of this apparatus must be commenced within 18 months of the date of purchase.

**CAUTION:** Rotating equipment must be guarded. Also refer to OSHA specifications and recommendations.

Zero-Max®, CD®, ETP®, ServoClass®, Torq-Tender®, Control-Flex®, Posi-Lok® and Roh'Lix® are registered trademarks of Zero-Max, Inc. OHLA™ is a trademark of Zero-Max, Inc.

© Zero-Max 2001 Printed in U.S.A.

# ////// ZERO-MAX®

13200 Sixth Avenue North, Plymouth, Minnesota 55441-5509  
800-533-1731 • (763) 546-4300 • Fax (763) 546-8260 • [www.zero-max.com](http://www.zero-max.com)