

General Purpose OEX Control

CBC-700 series

Simple, compact, high performance OEX control for either 90 or 24 VDC clutches and brakes. OEX spike duration and anti-overlap times delay are adjustable. Two optically isolated inputs.



- High performance
- Switch selectable OEX duration
- Force decay suppression with adjustable anti-overlap time delay
- Compact, flexible mounting
- Models for 24 or 90 volt clutches and brakes
- Cycle rate limited by clutch/brake



Specifications

	CBC-700-90	CBC-700-24
Part No.	6042-448-003	6042-448-002
Input	120 VAC, 50/60 Hz	24-28 VAC, 50/60 Hz
Output Voltages		
Steady State	90 VDC	24 VDC
Overexcitation	340 VDC	105 VDC
Output Current (Per channel alternately)	.5 Amps	3.5 Amps
OEX Pulse Duration	Adjustable through logic board dip switches (see service manual)	
Inputs	Two-optically isolated (10-30 VDC)	
Ambient Temperature Range	0°F to 140°F (-18°C to +60°C)	
Maximum Off State Leakage	<2 mA (inputs)	
Circuit Protection	2.5A Slo-Blo (5 x 20 mm)	5A Slo-Blo (5 x 20 mm)
Auxiliary Supply	12 VDC, 250 mA maximum	

Enclosure (Optional)



- Lift off hinge
- Quick-release latches
- Conforms to NEMA Type 13
- European Standard IEC 529, IP65

Part No.	6042-101-004
Size	8"H x 6"W x 4"D (203.2 x 152.4 x 101.6 mm)

Dimensions

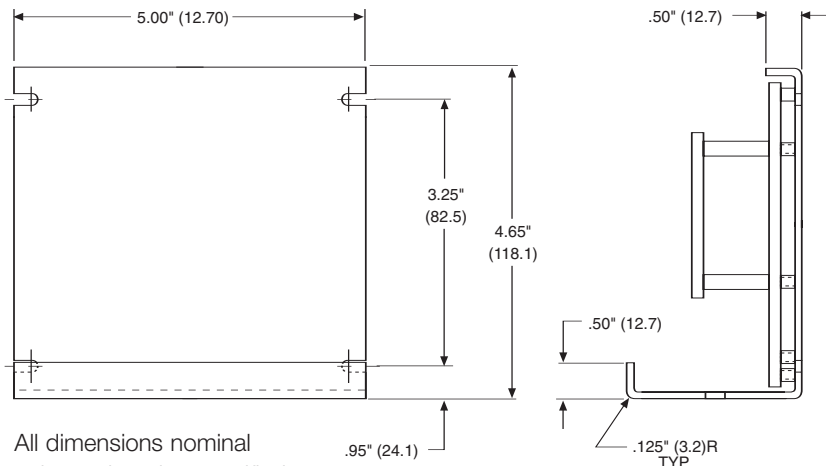

All dimensions nominal unless otherwise specified.

Connection Diagram

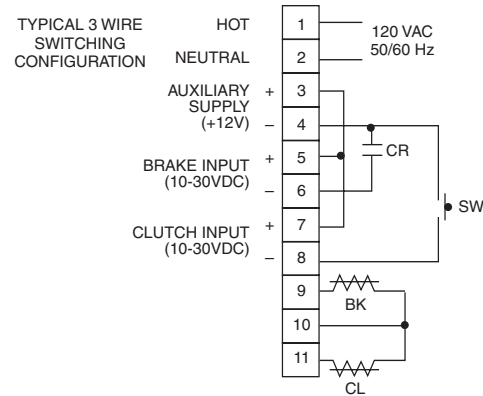

NOTE: CR, SW user furnished switch options for use with control.
 CR normally open relay contact
 SW normally open push button switch

Rapid Acceleration/Deceleration

**CBC-750 series
Dual channel, current based
OEX with switching logic**

Warner Electric's CBC-750 series of Constant Current Overexcitation Clutch/Brake Controls are solid-state electronic controls designed to increase the cycle rate capabilities and accuracies of electromagnetic clutches and brakes. The controls accomplish this by sending a momentary high voltage overexcitation spike to the clutch and/or brake magnetic coil to build a high density magnetic flux field almost instantaneously. By using overexcitation, the response time is reduced as dramatically as performance is increased. For example, the current build up time of a 5 inch, 6 volt magnet is reduced from 84 milliseconds to 2 milliseconds.

The CBC-750 user selects either 120, 220 or 240 VAC operation at the time of installation. Models for 6 volt, 24 volt, or 90 volt clutches and brakes are available.



- High performance OEX control
- Constant current output capability
- Models for 6, 24, and 90 V clutches and brakes
- Outputs short circuit protected.
- AC/DC optically isolated inputs
- Transformer isolation
Remote torque potentiometer capability
- Input/Output inhibit functions
- Switch selectable OEX function
- Automatic CH1/CH2 anit-overlap feature
- Heavy duty suppression circuits
- Selectable output current ranges
- Remote status indicators inputs and outputs



Shown with optional cover, part number 6041-101-004

LED indicators on the faceplate of each control tell the user the status of input signals, output activation and any auxiliary inputs. A reset switch resets the output should a short be detected. Remote torque adjust potentiometer inputs are also provided. Appropriate current range for each size clutch or brake is selected by a dip switch. Constant current for each level is assured by the control's design.

- Maintains torque at preset levels regardless of temperature variations
- Automatically controls OEX pulse duration for optimum response without overheating coils
- Automatically prevents clutch and brake "overlap"
- Configurable as an analog follower control through remote top input
- Integral switching logic through auxiliary, inhibit and override inputs

Specifications

	CBC-750-6	CBC-750-24	CBC-750-90
Part No.	6041-448-001	6041-448-002	6041-448-003
Input Power	120/220/240 VAC, ±10%, 50/60 Hz, 350 VA (switch selectable)		
Control Inputs	Opto-isolated 10-30 VDC @ 10-35 mA nominal sinking or sourcing, or 24 VAC (50/60Hz) @ 22 mA nominal, or 120 VAC (50/60 Hz) @ 20 mA nominal		
Clutch/brake Output			
Steady State Output			
Current controlled	.910 to 4.34 A max.	.227 to 1.175 A max.	.060-.310 A max.
Current Rise Time	Dependent on clutch/brake size		
Current Fall Time	Depending on clutch/brake size		
Overexcitation Voltage	75 VDC nom.	240 VDC nom.	450 VDC nom.
Overexcitation Time	Automatic adjustment by control feedback		
Anti-overlap Time	Automatic adjustment by control feedback		
Power Supply Output	12 VDC, ±0.6 VDC, 250 mA max.		
Auxiliary Indicator	Opto-isolated NPN transistors		
Outputs	24 VDC maximum, 20 mA max., reverse polarity protected		
Circuit Protection	Internal short circuit protection on each output channel.		
Fusing			
AC Input Line	2 Amp, 250 V Slo-Blo		
OEX Supply	10 Amp, 32 V Slo-Blo	5 Amp, 250 V Slo-Blo	1 Amp, 250 V Slo-Blo

Seven optically isolated inputs accept 10-30V A.C./D.C. (TB2) or 120 VAC (TB3), configured through set-up switches

1. Channel 2 Input
2. Channel 2 Input Inhibit (disregards channel 2 input signal)
3. Auxiliary Input
4. Channel 1 Input
5. Channel 1 Input Inhibit (disregards channel 1 input signal)
6. Output Inhibit (deactivates both output channels)
7. Channel 2 Override (applies full voltage to channel 1 output)

Connection Diagram

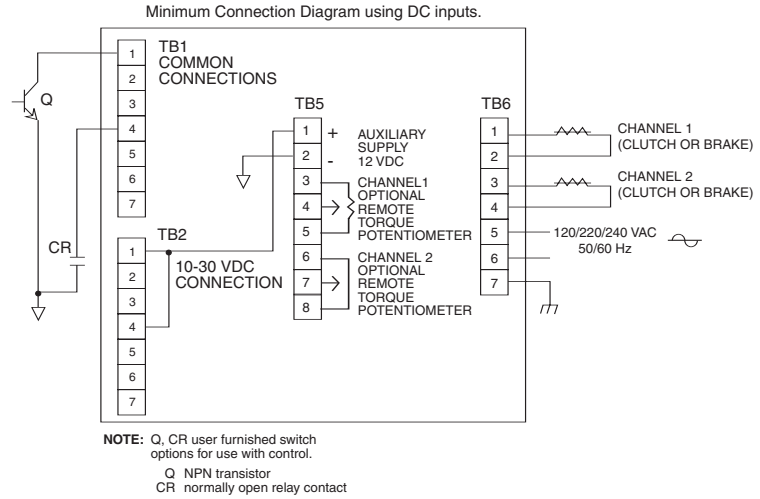

Dimensions

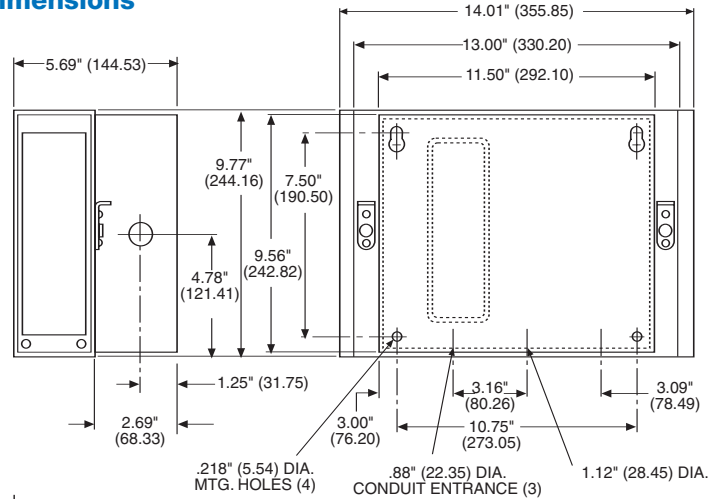

All dimensions nominal unless otherwise specified.

Setup Switches

SW1: AC Voltage selection switch on terminal board inside control unit

Max. Current Output

(SW7 & SW8 settings)

Nominal Voltage	1	2	3	4	5
6	0.910	2.35	3.183	3.760	4.340
24	0.227	0.641	0.881	0.940	1.175
90	0.060	0.176	0.256	0.282	0.310

SW8

Channel 2 current range selector (settings in diagram below)

SW7

Channel 1 current range selector (settings in diagram below)

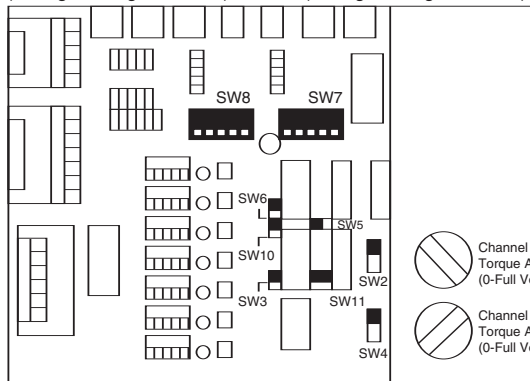

All switches are in the down (∩) position from factory

SW6

Channel 2 OEX enable (∩) / disable (∪)

SW5

Channel 1 OEX enable (∩) / disable (∪)

SW10

Channel 1 input invert ∩ (∩) ∪ (∩)

SW2

Channel 1 local (∩) or remote (∩) torque adjust

SW3 Level/pulse selector level (∩) pulse (∩)

SW4

Channel 2 local (∩) or remote (∩) torque adjust

SW11

Auxiliary input selector Channel 1 (∩) Channel 2 (∩)