

CB Mounting Requirements

CB Mounting Requirements

While Warner Electric wrap spring clutches are self-contained, packaged products, which are easy to mount, a few simple precautions should be taken to ensure maximum life.

All Warner Electric wrap spring clutch products are designed to be installed in parallel shaft applications where they are fully supported by the shaft on which they are mounted.

Each clutch/brake backing plate assembly has three or four mounting holes, plus an anti-rotation slot, and is designed to serve as a torque arm rather than as a rigid mounting plate. The plate should be restrained from rotating by a pin or shoulder bolt, while allowing for the plate to float axially. The anti-rotation device must be capable of withstanding the braking torque required by the load.

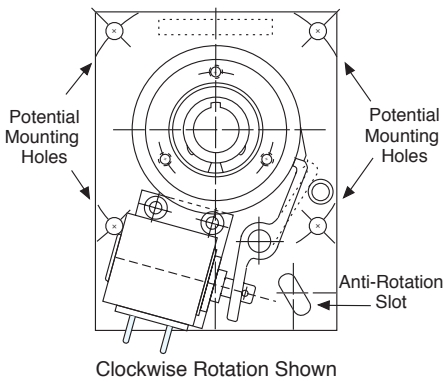

Important: Do not rigidly mount unit. Plate must be allowed to “float” axially.

On CB type units, the input rotation is always connected to the input hub, and the output is always through the shaft through the hollow bore of the clutch/brake.

Connecting the unit to the parallel shaft may be accomplished by pinning (for sizes 2, 4, and 5) or by key and set screw (for sizes 6 and 8).

When connecting the parallel shaft to the CB by using a belt, chain or gear drive, the input hub's radial bearing load capacity must not be exceeded. (See chart in next column). It may be necessary to counter bore or bearing mount the input pulley sprocket or gear.

Maximum Radial Bearing Load at Maximum Speed

- CB-2 = 7.5 lbs.
- CB-4 = 14 lbs.
- CB-5/Super CB-5 = 32 lbs.
- CB-6/Super CB-6 = 63 lbs.
- CB-8/Super CB-8 = 300 lbs.

CB and Super CB style clutch/brakes are designed for horizontal shaft mounting. While it is possible to mount units vertically, vertically mounted units will see lower life than those mounted horizontally due to the wear between hubs resulting from gravity.

Horizontal Mounting

Figure 1 illustrates an ideal CB mounting. The unit is attached to the output shaft with both a key and set screws. The plate is restrained from rotating, but not from axial movement, reducing the side load on the CB's internal plate bearing.

In cases where easy access to the input is desirable, the clutch/brake can be mounted on a stub shaft. However, the unit must still be fully supported, while overhanging loads on the input member must be avoided to maintain the life of the radial bearing.

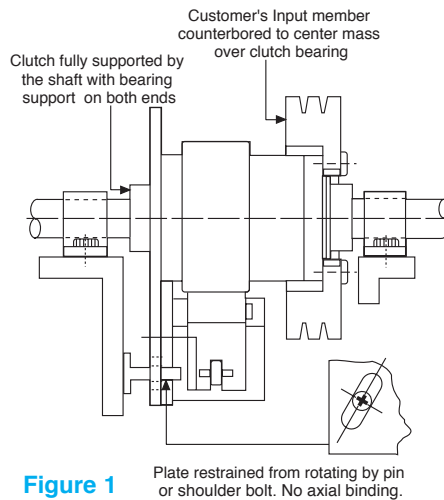

Figure 1

Figures 2 and 3 illustrate alternate mounting configurations for achieving proper support. Inputs are usually face-mounted to the input hub of the CB unit as shown in Figure 1. This type of mounting is facilitated by the drilled and tapped holes provided in the free hub flange. The configuration shown in Figure 2 is a possibility, if the radial load on the input hub of the CB is small compared to the specified load.

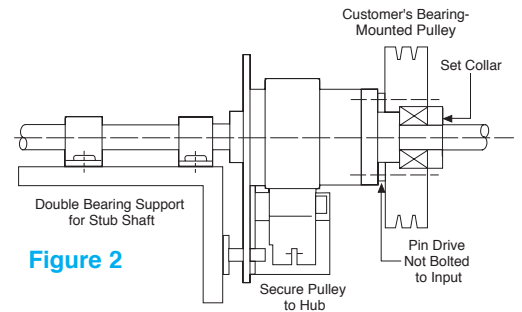

Figure 2

If the application contains a substantial radial bearing load, arrange the pulley over the centerline of the clutch free hub as illustrated in Figure 3. Place one support bearing as close to the pulley as possible, using a torque arm for anti-rotation.

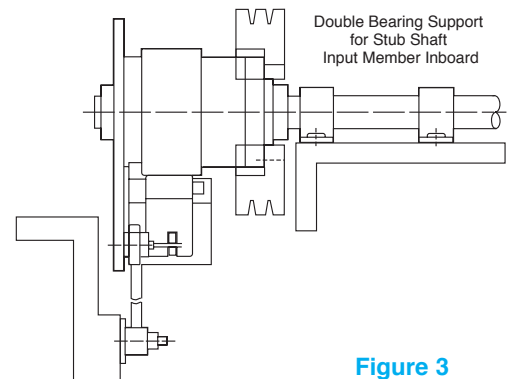

Figure 3

The smaller CB units (sizes 2, 4 and 5) have pilot holes in the output shaft, which guide drilling through the machine shaft for attaching the unit with a pin.

Vertical Mounting

When it is necessary to mount a unit vertically, mount it so the input hub is oriented in the upward position as illustrated in Figure 4.

Figure 4

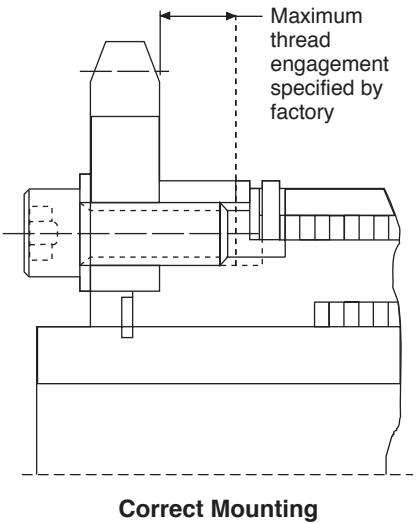
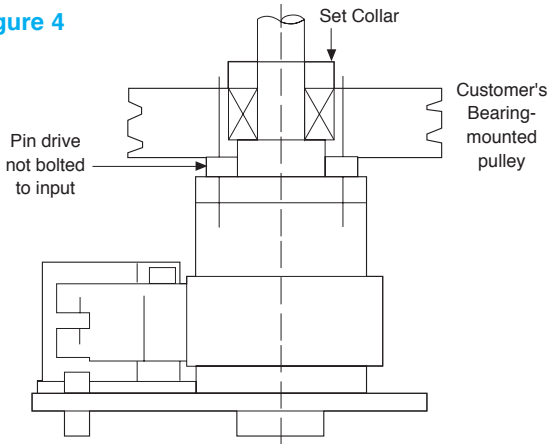

Thread Engagement Requirements

Just a reminder . . . While mounting a sprocket or pulley to the input hub of your CB-2, CB-4, CB-5, CB-6 or CB-8 the screws/bolts used must not protrude through the flange or hub. This will interfere or jam the control collar assembly, therefore causing the clutch to malfunction by failing to "drive" or causing the clutch to "slip." Please refer to the following chart for maximum thread engagement:

- CB-2 = .150 in.
- CB-4 = .280 in.
- CB-5/Super CB-5 = .350 in.
- CB-6/Super CB-6 = .312 in.
- CB-8/Super CB-8 = .360 in.

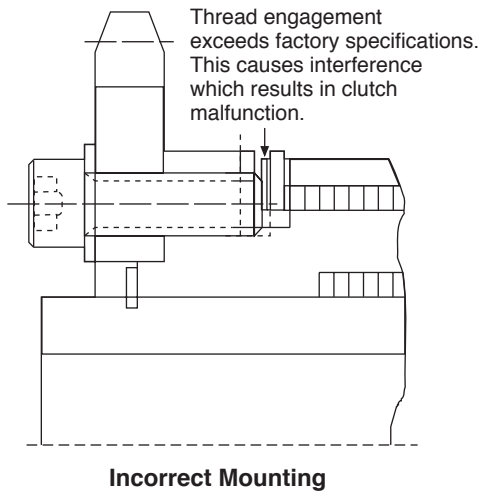

For further information and/or assistance, please call Warner Electric Technical Support at 800-825-9050.

CB Stop Collar Adjustment

CB Stop Collar Adjustment

Each CB and Super CB Series unit has an incrementally adjustable collar, which allows for changes to the output orientation.

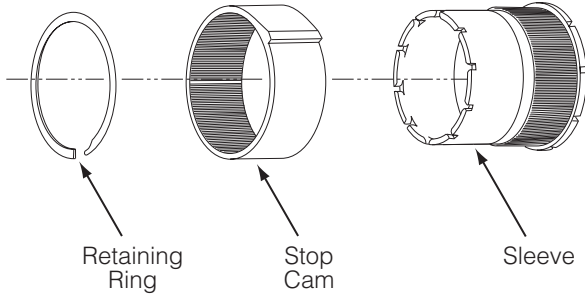

To adjust the stop collar output orientation:

- Wrap the brake spring down completely by rotating the output shaft in the driving direction until it cannot travel any further;
- Remove the retaining ring from its groove and slide it forward on the sleeve; then,
- Hold the actuator clear, while sliding the stop cam off the sleeve. Rotate the cam to the desired stop position, and slide it back onto the sleeve; and,
- Slide the retaining ring back into position.

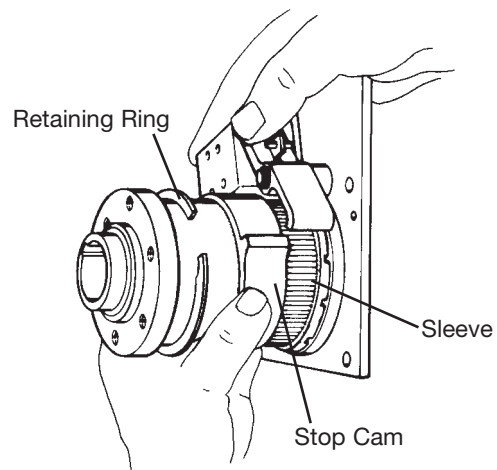

Adjustment Increments With Standard Stop Collars

CB-2	Infinitely Adjustable
CB-4	2.4° Adjustable
CB-5/Super CB-5	1.8° Adjustable
CB-6/Super CB-6	1.8° Adjustable
CB-8/Super CB-8	1.6° Adjustable

CB Spring Differential Setting

All CB and Super CB Series clutch/brakes are factory-set to the proper spring differential overtravel. If a spring must be replaced, prior to disassembly, make sure the two spring tang slots are marked to help ensure proper reassembly. (There should be punch marks from the factory on either side of the spring tang slots marking those used for the correct differential setting.) If the slots are unmarked and the unit has been disassembled, use the following procedure to reset the spring differential.

1. Remove the retaining ring from the input hub.
2. Rotate the clutch so the brake spring is fully wrapped down by rotating the output shaft in the driving direction until it cannot travel any farther.
3. With the brake fully engaged (per step 2), pull the input hub assembly out, and push the clutch spring out of its slot, allowing it to jump to wherever it comes to rest.
4. Unwrap the clutch spring and push it backwards into the nearest slot.
5. Push the input hub back into place, release the actuator, and rotate the clutch until the brake spring fully wraps down again.
6. With the brake fully engaged (wrapped down per step 2), hold the shaft with one hand and release the actuator. The stop collar will rotate forward as the brake is released and the clutch engages.

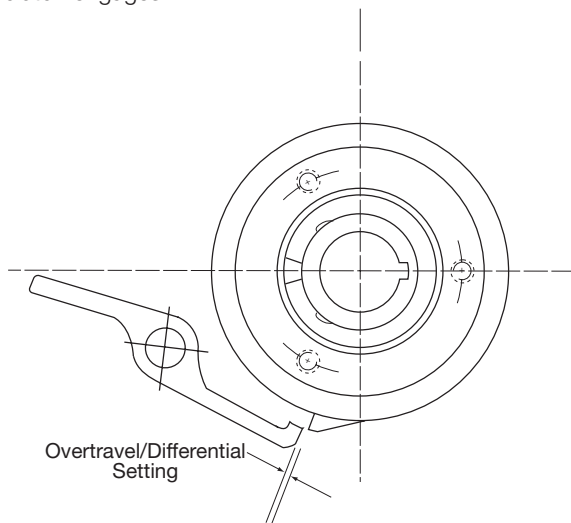

7. To calculate the overtravel, use a scale to measure the distance between the tip of the actuator, and the tip of the stop on the cam

The Amount of Acceptable Overtravel Varies with the Size of the Unit

CB-2	.09 to .19"
CB-4	.09 to .19"
CB-5/Super CB-5	.09 to .19"
CB-6/Super CB-6	.22 to .38"
CB-8/Super CB-8	.30 to .60"



MEX (55) 53 63 23 31 MTY (81) 83 54 10 18
 QRO (442) 1 95 72 60 ventas@industrialmagza.com

8. If the overtravel measurement is within these specified limits, reinstall the retaining ring and the unit's overtravel is reset.
- 9 A. If the overtravel *exceeds* the specified limit, move the brake spring backwards one slot (against the direction of rotation) and repeat steps two through seven.
- B. If the overtravel *is less than* the specified limit, move the brake spring forward one slot (in the direction of rotation,) and repeat steps two through seven.

If Spring Replacement Is Not Required

If the unit is disassembled and the drive and/or brake springs do not need to be replaced, proceed as follows:

- Reposition the drive and brake springs into their original positions onto the output shaft assembly.
- Reassemble the clutch, and position the spring tangs of the drive and brake springs in the factory marked locations on the control collar assembly (on the control collar, the designated tang slots are indicated with punch marks on either side of each slot).
- After the unit is completely reassembled, the differential setting should match that of the original factory setting.