

WSC Series Clutches

Mechanically Activated, Basic Wrap Spring Clutch Design

WSC Series wrap spring clutches are mechanically actuated, eliminating the need for external electrical control devices. These simple, trouble free, easy-to-install clutches feature a high torque capacity in a small, compact package.

A choice of three different operating styles is available.

Features

- Five standard sizes
- Standard bore sizes from 1/4" to 1-1/2"
- Static torque rating from 25 lb.in. to 2500 lb.in.
- Mechanically actuated
- Choice of hub or shaft input
- 1, 2 or 4 stop collars standard
- Overtravel stop
- Anti-overrun
- Adjustable stop feature
- Self-lubricating, no maintenance
- Simple mechanical actuation
- Easy-to-machine hubs readily adapt to application needs
- Single stop collars for single revolution operation
Multistops for less than one turn



Overrunning/One-Way (Model O)

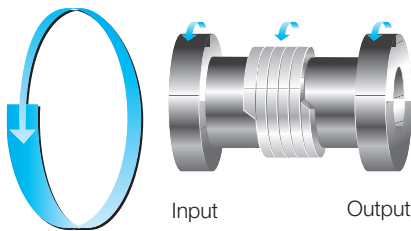

The overrunning clutch (Model O) transmits torque up to the rated value in the positive direction, when disengaged it only transmits some drag torque in the reverse direction. Major applications for this unit are anti-overrun protection and anti-backup devices.

The load is allowed to overrun the input, should the load speed exceed the input speed. In reverse it acts as a one-way clutch, preventing reverse rotation.

Start/Coast-To-Stop (Model SS)

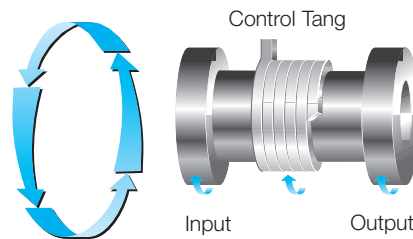

The start/coast-to-stop clutch (Model SS) accelerates the load just after the control collar has been released, thus the collar is free to rotate allowing the spring to grip both hubs together. To disconnect the clutch, the collar has to be restrained, stopping the collar from rotating via the stop face. The spring will then be opened and the clutch will be disengaged. The output is free to rotate and will be stopped by system friction and clutch drag torque.

The start/coast-to-stop clutch is engaged until the collar is stopped, which disengages the clutch allowing the load to coast to a stop.

Single Revolution (Model S)

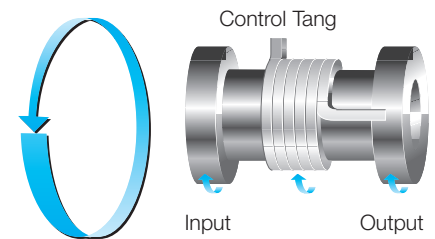

The single revolution clutch (Model S) accelerates in the same manner as the model SS. The deceleration starts when the collar is restrained, and the spring is opened, disengaging the clutch.

For Model S, the brake torque capability is limited to 10% of the rated torque.

All WSC Series clutches are easy to install. The shaft can be pinned or, on larger units, delivered with keyways, a simple solution for applications requiring accurate positioning. One, two or four stop per revolution collars are available.

Specifications	WSC-2	WSC-4	WSC-5	WSC-6	WSC-8
Static Torque (lb.in.)	25	120	250	500	2500
Inertia, shaft input rotating parts (lb.in. ²)	0.006	0.015	0.059	0.570	4.99
Inertia, hub input rotating parts (lb.in. ²)	0.008	0.023	0.069	0.73 (0.75" Bore) 0.68 (1.00" Bore)	11.91 (1.25" Bore) 11.60 (1.50" Bore)
Maximum radial bearing load at maximum speed (lbs.)	6.75	13.5	31.5	63.0	300.0
Maximum operating speed (RPM)	1800	1200	750	500	300
Weight (lbs.)	0.13	0.22	0.62	2.60	8.25

See page 32 for Minimum Inertia Requirements.
See page 8 for Mounting Instructions.

Optional Multiple Stop Collars



The WSC Series clutches feature a choice of collars with one, two or four stops as standard. Other stop collar configurations are available on special order.

Basic Selection

See pages 6–7 for basic product selection guidelines.

For complete Application Engineering information see pages 32–34.

How to Order

Order by part number (see chart on dimension pages) or specify as follows:

Specify:

1. WSC Series
2. Size: WSC-2, WSC-4, WSC-5, WSC-6, or WSC-8
3. Type of Operation:
S—Single revolution
SS—Start/Coast-To-Stop
O—Overrunning
4. Direction of rotation:
CW Clockwise
CCW Counterclockwise
(Direction of rotation is determined from the perspective of the input end.)
5. Hub input (HI) or shaft input (SI)
6. Standard Bore size:
WSC-2 = 1/4"
WSC-4 = 3/8"
WSC-5 = 1/2"
WSC-6 = 3/4" or 1"
WSC-8 = 1 1/4" or 1 1/2"

7. Stop collar:
Standard Stops: 1, 2 or 4

Example: WSC-6, S, CCW, HI, 1" bore, 4 stop collar.

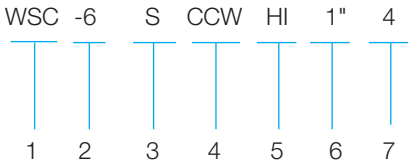

WSC-2, WSC-4, WSC-5 Clutches

Dimensions (mm)

WSC-2

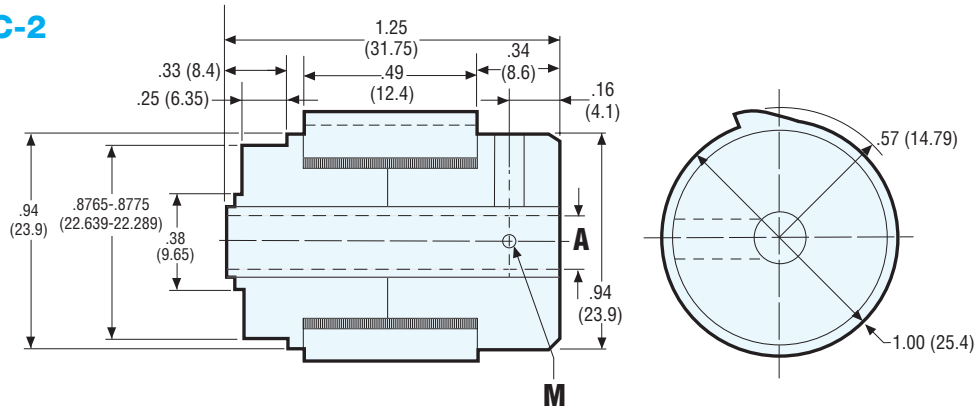

WSC-4

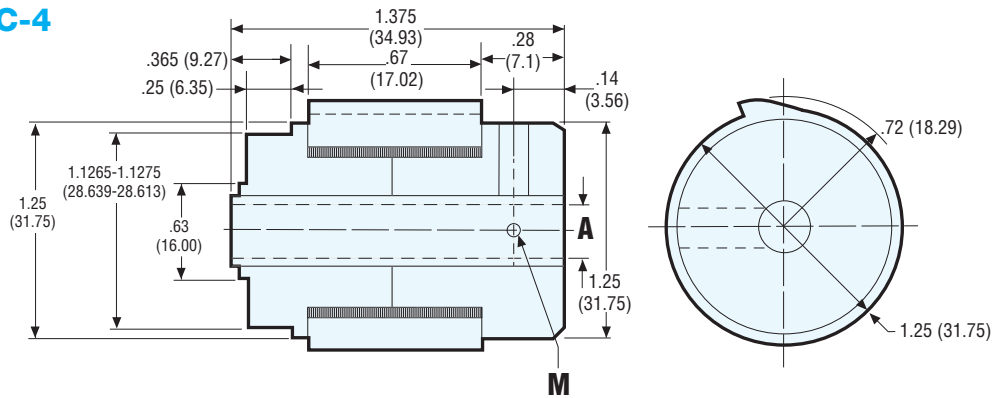

WSC-5

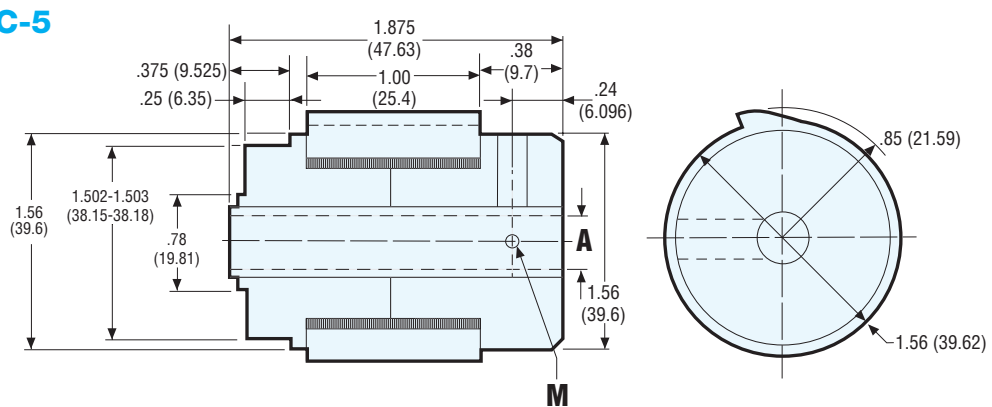

INDUSTRIAL MAGZA MEX (55) 53 63 23 31 MTY (81) 83 54 10 18
 DIST. AUTORIZADO QRO (442) 1 95 72 60 ventas@industrialmagza.com

WSC-2, WSC-4, WSC-5 Clutches

Part Numbers

WSC-2

Bore Size	Operation	Rotation	Input	Stops		
				1	2	4
0.25"	S (start/stop)	CW	Hub	202-10-016	202-10-009	202-10-020
0.25"	S (start/stop)	CCW	Hub	202-20-016	202-20-015	202-20-017
0.25"	S (start/stop)	CW	Shaft	202-30-011	202-30-007	202-30-015
0.25"	S (start/stop)	CCW	Shaft	202-40-014	202-40-008	202-40-017

These are the most commonly requested parts. Other units offering overrunning or start/coast-to-stop operation are available.

WSC-4

Bore Size	Operation	Rotation	Input	Stops		
				1	2	4
0.375"	S (start/stop)	CW	Hub	204-10-001	204-10-016	204-10-010
0.375"	S (start/stop)	CCW	Hub	204-20-004	204-20-008	204-20-016
0.375"	S (start/stop)	CW	Shaft	204-30-001	204-30-007	204-30-009
0.375"	S (start/stop)	CCW	Shaft	204-40-001	204-40-006	204-40-012

These are the most commonly requested parts. Other units offering overrunning or start/coast-to-stop operation are available.

WSC-5

Bore Size	Operation	Rotation	Input	Stops		
				1	2	4
0.5"	S (start/stop)	CW	Hub	205-10-001	205-10-014	205-10-017
0.5"	S (start/stop)	CCW	Hub	205-20-001	205-20-006	205-20-011
0.5"	S (start/stop)	CW	Shaft	205-30-001	205-30-014	205-30-016
0.5"	S (start/stop)	CCW	Shaft	205-40-004	205-40-016	205-40-007

These are the most commonly requested parts. Other units offering overrunning or start/coast-to-stop operation are available.

Bore Data

Model	Bore	
	A	M
WSC-2	.2505-.2503 (6.363-6.426)	#8-32
WSC-4	.3755-.3780 (9.538-9.601)	.125 dia. (3.175 dia.)
WSC-5	.5005-.5030 (12.713-12.776)	.187 dia. (4.75 dia.)

All dimensions are nominal unless otherwise noted.

Specifications	WSC-2	WSC-4	WSC-5
Static Torque (lb.in.)	25	120	250
Inertia, shaft input rotating parts (lb.in. ²)	0.006	0.015	0.059
Inertia, hub input rotating parts (lb.in. ²)	0.008	0.023	0.069
Maximum radial bearing load at maximum speed (lbs.)	6.75	13.5	31.5
Maximum operating speed (RPM)	1500	1200	750
Weight (lbs.)	0.13	0.22	0.62

WSC-6, WSC-8 Clutches

WSC-6

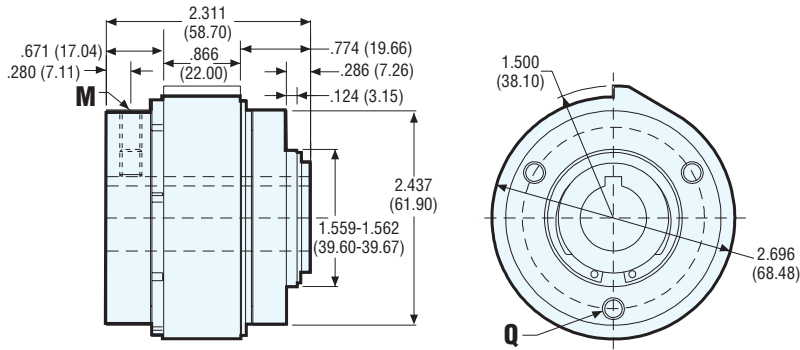

WSC-8

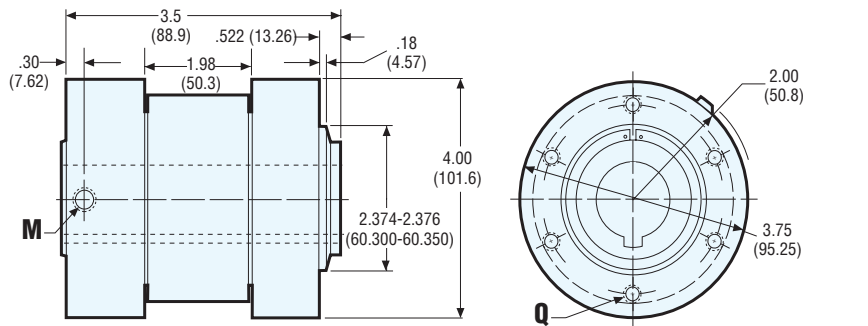

Bore & Keyway Data All dimensions are nominal unless otherwise noted.

Model	Bore A	Keyway Width B	Keyway Height C	M	Q
WSC-6	.7505-.7525 (19.063-19.114)	.1885 (4.788)	.09375 (2.381)	#1/4-20 Tap	3x #1/4-20 Tap on 2.062 (52.375) BC Max. Thread Engagement .310 (7.87)
WSC-6	1.0005-1.0025 (25.412-25.464)	—	—	#1/4-20 Tap	3x #1/4-20 Tap on 2.062 (52.375) BC Max. Thread Engagement .310 (7.87)
WSC-8	1.2505-1.2530 (31.762-31.814)	.3125 (7.9375)	.15625 (3.9688)	3/16-16	6x 5/16-18 on 3.375 (85.725) BC Max. Thread Engagement .375 (9.53)
WSC-8	1.5005-1.5030 (38.113-38.176)	.375 (9.525)	.125 (3.175)	3/16-16	6x 5/16-18 on 3.375 (85.725) BC Max. Thread Engagement .375 (9.53)

INDUSTRIAL MAGZA
 MEX (55) 53 63 23 31 MTY (81) 83 54 10 18
 QRO (442) 1 95 72 60 ventas@industrialmagza.com
 DIST. AUTORIZADO

Part Numbers

WSC-6

Bore Size	Operation	Rotation	Input	Stops		
				1	2	4
0.75"	S (start/stop)	CW	Hub	206-10-002	206-10-062	206-10-064
0.75"	S (start/stop)	CCW	Hub	206-20-002	206-20-023	206-20-058
0.75"	S (start/stop)	CW	Shaft	206-30-011	206-30-052	206-30-025
0.75"	S (start/stop)	CCW	Shaft	206-40-002	206-40-014	206-40-020
1.0"	S (start/stop)	CW	Hub	206-10-003	206-10-057	206-10-059
1.0"	S (start/stop)	CCW	Hub	206-20-003	206-20-060	206-20-013
1.0"	S (start/stop)	CW	Shaft	206-30-003	206-30-051	206-30-056
1.0"	S (start/stop)	CCW	Shaft	206-40-013	206-40-023	206-40-025

These are the most commonly requested parts. Other units offering overrunning or start/coast-to-stop operation are available.

WSC-8

Bore Size	Operation	Rotation	Input	Stops		
				1	2	4
1.25"	S (start/stop)	CW	Hub	208-10-004	208-10-027	208-10-028
1.25"	S (start/stop)	CCW	Hub	208-20-001	208-20-028	208-20-030
1.25"	S (start/stop)	CW	Shaft	208-30-001	208-30-021	—
1.25"	S (start/stop)	CCW	Shaft	208-40-013	208-40-015	208-40-017
1.50"	S (start/stop)	CW	Hub	208-10-007	208-10-025	208-10-030
1.50"	S (start/stop)	CCW	Hub	208-20-003	208-20-032	208-20-021
1.50"	S (start/stop)	CW	Shaft	208-30-003	208-30-025	208-30-027
1.50"	S (start/stop)	CCW	Shaft	208-40-003	208-40-020	208-40-022

These are the most commonly requested parts. Other units offering overrunning or start/coast-to-stop operation are available.

Specifications	WSC-6	WSC-8
Static Torque (lb.in.)	500	2500
Inertia, shaft input rotating parts (lb.in. ²)	0.570	4.99
Inertia, hub input rotating parts (lb.in. ²)	0.73 (0.75" Bore) 0.68 (1.00" Bore)	11.91 (1.25" Bore) 11.60 (1.50" Bore)
Maximum radial bearing load at maximum speed (lbs.)	63	300
Maximum operating speed (RPM)	500	300
Weight (lbs.)	2.60	8.25