

# Magnetic Particle Brakes and Clutches

Accurate torque control with instantaneous engagement!



## Available in a wide range of models and sizes

Warner Electric's magnetic particle brakes and clutches are quiet and clean and provide outstanding performance in slipping and torque control applications. They are ideal for unwind, rewind, and intermittent (point to point) tension applications. They are also ideal for controlled starting or stopping, torque limiting and cycling applications.

These units use high quality materials and unique designs to provide precision performance, superior heat dissipation and extremely long life. The magnetic powder, made from a patented alloy, provides extreme resistance to heat and wear, and, therefore, promotes long life and high thermal ratings. Also, one of the brake models, the PTB, incorporates a patented heat pipe that further extends its thermal capability. PTB units have thermal ratings three times higher than brakes with natural cooling and equivalent to water-cooled brakes.

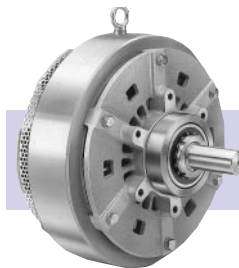

### Brakes

Six different brake models are available: four with male shafts and two

with hollow bores. The units with hollow bores can be shaft-mounted, if desired. Final selection is determined by torque and thermal requirements. The product selection section provides more specific information on these models.

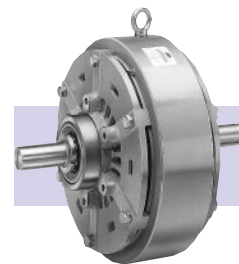

### Clutches

Three different clutch models, each with several sizes, are available to

handle a variety of applications. The face-mounted models can be used in parallel or inline applications. The shaft-mounted units offer a second option for parallel shaft applications and are ideal for tension rewind applications. Please see the product selection section for more specific information.

## Features and Benefits

### Precise Control

- Spherical particles provide smooth torque independent of speed. Low speed chatter is also eliminated.
- The magnetic circuit is designed to produce torque proportional to current.
- Unique design requires only one powder seal, thus reducing drag torque and allowing for a wider operating range.

### Extremely Long Life

- Spherical particles made from a patented alloy provide outstanding resistance to corrosion and mechanical breakdown.

### High Heat Dissipation

- One of the models, the PTB, uses a patented heat pipe that provides heat dissipation levels equal to water-cooled units and several times greater than natural cooling.
- The shaft mounted clutches provide self-cooling through the use of an integral fan that rotates with the input.

### Clean Operation

- All models are completely enclosed. Ideal for applications where clean operation is desired.

### Easy to Mount

- Precision pilots are provided to position units for easy installation.
- Clutches and brakes with hollow bores are offered for applications where shaft mounting is desired.

### Smooth Engagement

- Torque characteristics provide for smooth and controllable acceleration or deceleration of the load.

### Fast Response

- Fine particles respond quickly to field for millisecond engagement, if required.

### No Maintenance

- Adjustment or lubrication is not required.

### Quiet Operation

- Engagement is smooth and quiet.

### Low Current Draw

- Efficient magnetic circuit design allows for minimal current draw.

### Torque independent of slip speed

Torque is transmitted through magnetic particle chains that are formed by an electromagnetic field. The torque is independent of slip speed, depending only on circuit current, and is infinitely variable from 0 (disengaged) to rated torque.

### No wearing parts

There are no friction surfaces to grab or wear, and the units are not affected by changes in atmospheric or other environmental conditions.

### Efficient/Compact design

High torque to size ratio and low electric power consumption.

### Versatile mounting

Convenient bolt circle for easy mounting. Mounting brackets available for all sizes. Brakes are available with solid shafts and through bores. Can be mounted horizontally or vertically to solve virtually any motion control requirement.

### Distributor Item

Off the shelf availability. Interchangeable with industry standard sizes.

## Specials Designs

### ▪ **Special Shaft Configurations**

Customer specified shaft configurations for easy machine mounting and retrofitting.

### ▪ **Wash Down Environment**

Stainless steel units available for extreme environments.

### ▪ **Special Torque**

Maximum torque configurations to meet customer specifications.

### ▪ **Special Mounting Configurations**

Customer specified bolt patterns, special mounting brackets.

### ▪ **Metric units**

# Magnetic Particle Brakes and Clutches

## Design and Operation

Warner Electric magnetic particle clutches and brakes are unique because of the wide operating torque range available. Torque to current is almost linear and can be controlled very accurately. The unique features of the magnetic particle clutches and brakes make them ideal for tension control, load simulation, cycling/ indexing, and soft starts and stops. Controls information starts on page 40.

### MPB Products

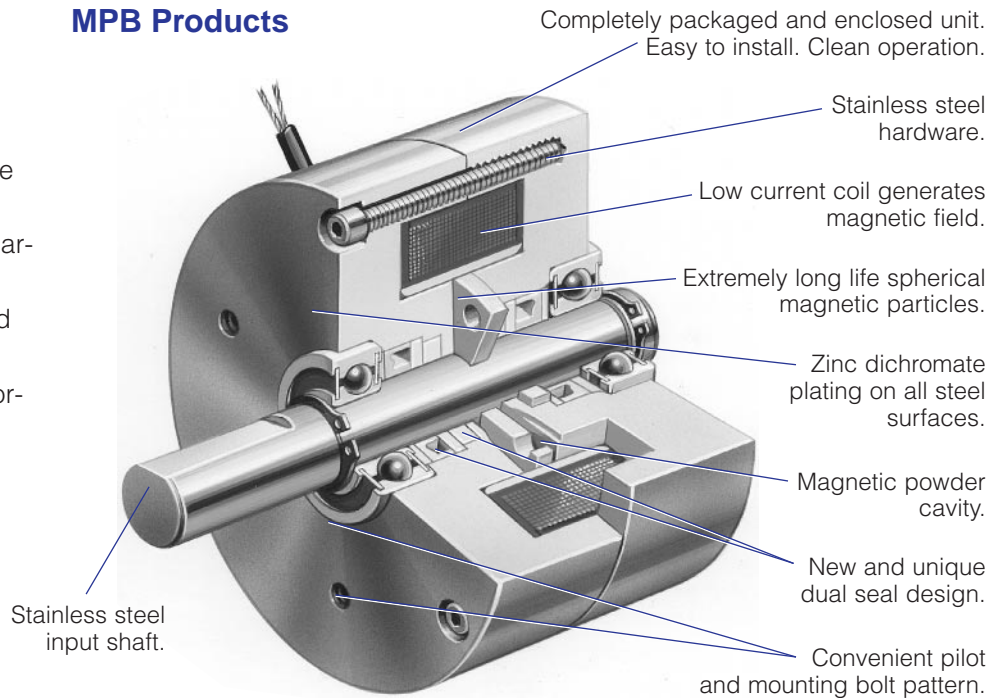

### PTB Brake

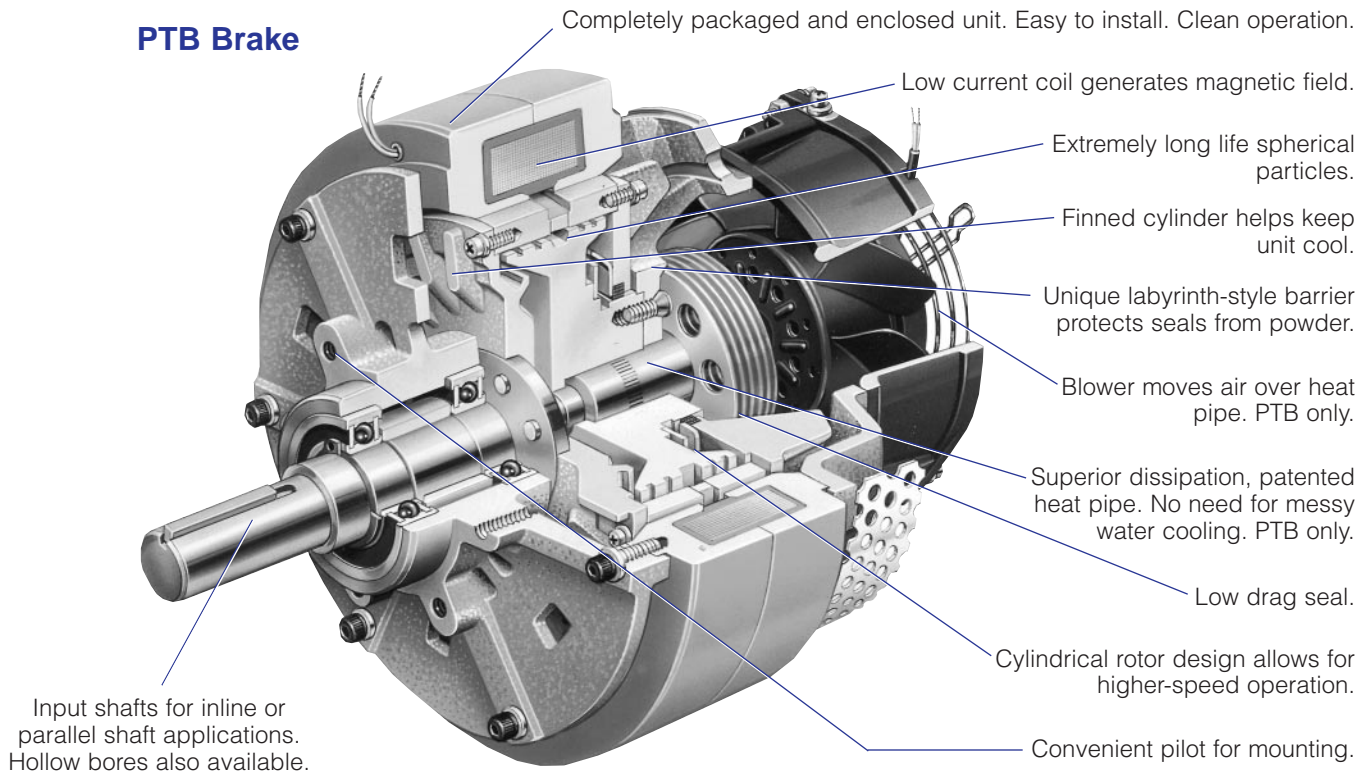

# Magnetic Particle Brakes and Clutches

## POC Clutch

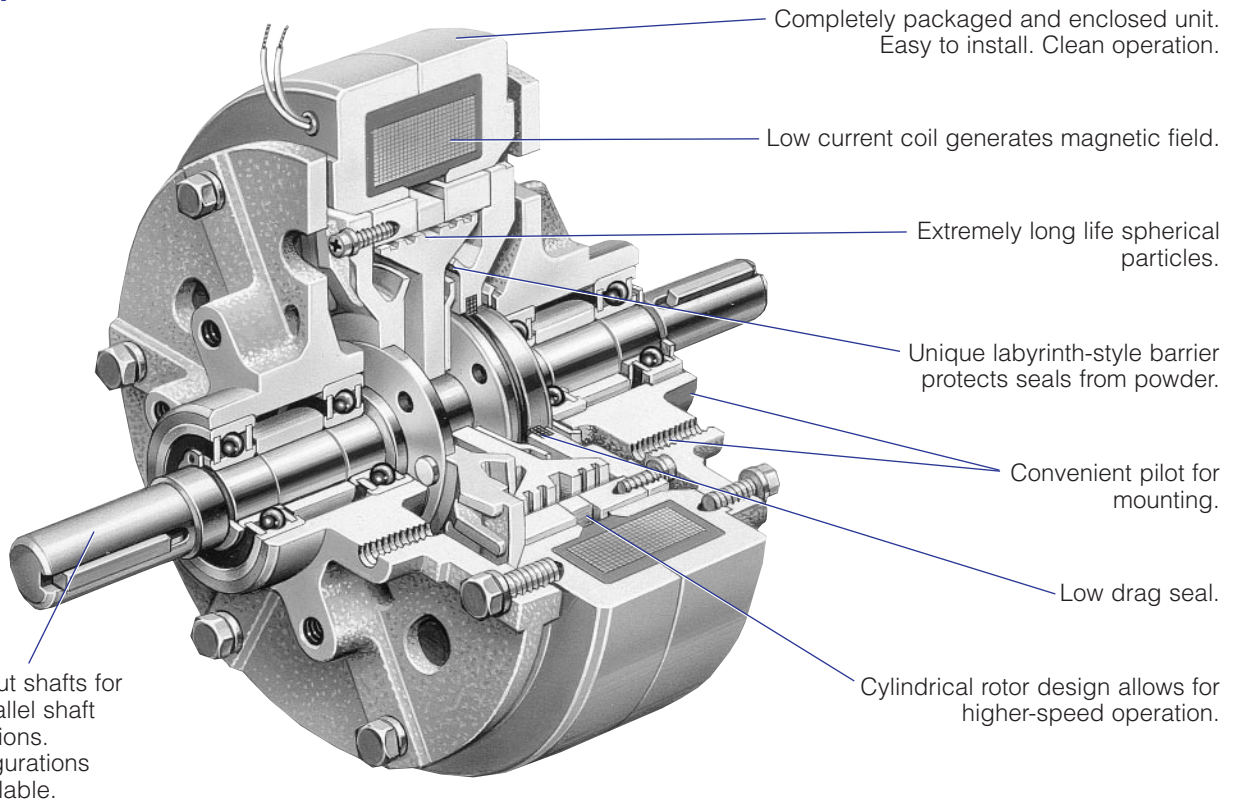

## Principle of Operation

The magnetic particle unit consists of four main components: 1) housing; 2) shaft/disc; 3) coil and 4) magnetic powder. The coil is assembled inside the housing. The shaft/disc fits inside the housing/coil assembly with an air gap between the two; the air gap is filled with fine magnetic powder.

### Engagement

When DC current is applied to the magnetic particle unit, a magnetic flux (chain) is formed, linking the shaft/disc to the housing. As the current is increased, the magnetic flux becomes stronger, increasing the torque. The magnetic flux creates extremely smooth torque and virtually no “stick-slip”.

### Disengagement

When DC current is removed, the magnetic powder is free to move within the cavity, allowing the input shaft to rotate freely.

### Cycling

A cycling effect is achieved by turning the current to the coil on and off.

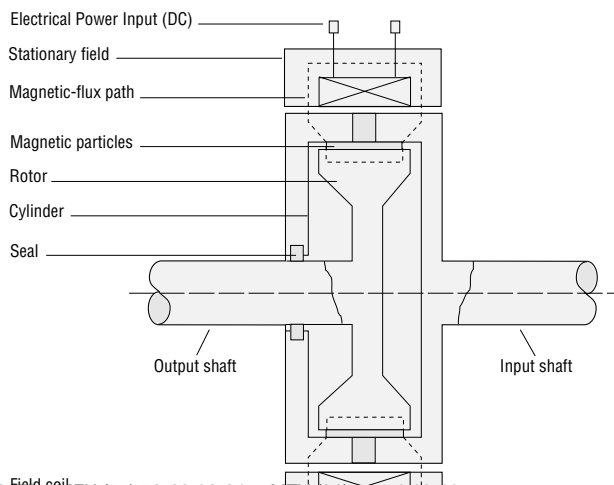
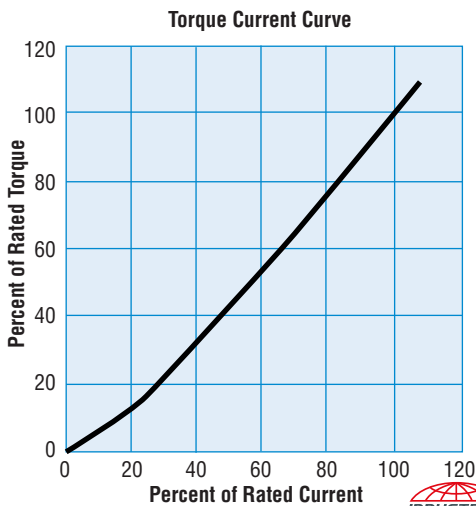

# Magnetic Particle Brakes and Clutches











## Selection

Unit torque ratings go from as low as 2.0 lb.in. to as high as 578 lb.ft. Also, many models are available to handle specific mounting requirements. The clutch family has three options. The MPC and POC have shaft inputs and outputs and is ideal for inline applications. The PHC models have a hollow bore and can be shaft-mounted for parallel shaft applications. The PMC clutch covers the lower end of the torque range and has a flanged input hub. Also, this unit is often mounted as a brake.

The brake family includes seven models. The MPB covers the low torque ranges and comes with shaft inputs or hollow bores. The POB is a shaft input brake that covers the medium and high torque extremes of the torque range. The PRB series covers the mid range. With four models that have different input and housing options. The PTB model uses a patented heat pipe cooling method that has a cooling capacity equivalent to water-cooled units, but without the hassles of water cooling.

## Selection Requirements

To properly size a magnetic particle brake or clutch, torque transmitted and heat generated must be considered. If you know these values, refer to the specifications and thermal curves to select a unit. For sizing and selection calculation see pages 13 through 30. To select a control for your application refer to the control section on pages 40 & 41.

Product	Model	Torque Ratings (lb.ft.)	Heat Dissipation Ratings Watts [HP <sub>T</sub> ]
Brake	 <b>MPB</b>	0.17 lb.ft.–20 lb.ft.	10–200 [0.013 to 0.27]
	 <b>POB</b>	2.1, 4.3, 289, and 578	60 to 4,000 [0.080 to 5.36]
	 <b>PRB-H</b>	8.6 to 144	95 to 575 [0.13 to 0.77]
	 <b>PRB-HF</b>	8.6 to 144	110 to 750 [0.15 to 1.00]
	 <b>PRB-S</b>	8.6 to 144	102 to 660 [0.14 to 0.88]
	 <b>PRB-SF</b>	8.6 to 144	121 to 800 [0.16 to 1.07]
	 <b>PTB-BL3</b>	18 to 144	500 to 4,100 [0.67 to 5.50]
Brake or Clutch	 <b>PMC-A3</b>	0.72 to 2.8 (8.6 to 34 lb. in.)	30 to 66 [0.040 to 0.088]
Clutch	 <b>MPC</b>	0.17 lb.ft. to 10.0 lb.ft.	10 to 140 [0.13 to 0.188]
	 <b>PHC-R</b>	4.3 to 144	70 to 1,150 [0.094 to 1.54]
	 <b>POC</b>	2.1 to 578	60 to 4,000 [0.080 to 5.36]

# Magnetic Particle Brakes and Clutches

Description	Cooling Method	Applications	Dimension Drawings (page no.)
Low and high torque units. Light duty thermal. All brakes have output shafts and pilots for mounting. Optional brackets available.	Natural	Tension unwind, light duty unwind	102
Low and high torque units are offered in this model. All units have male input shafts and pilots for mounting, except for the size 80, which is foot-mounted.	Natural	Tension unwind	104–105
This is the basic PRB model. It is offered with a hollow bore and a pilot for mounting.	Natural	Tension unwind	106
Like the PRB-H, this model has a hollow bore and mounting pilot, but it also has a finned housing for increased heat dissipation.	Natural with finned housing	Tension unwind	107
This model has a pilot for mounting, like the PRB-H. However, it has a male input shaft instead of a hollow bore.	Natural	Tension unwind	108
This version of the PRB has both the male input shaft and a finned housing for increased heat dissipation. It also is pilot mounted.	Natural with finned housing	Tension unwind	109
The PTB-BL3 offers superior heat dissipation capability. Units are pilot-mounted and a male input shaft is provided for connecting to the load.	Heat Pipe with 115VAC blower	Tension unwind, load for testing. Ideal for applications requiring high heat dissipation	103
These units offer precise control in the small tension ranges. They have flanged input hubs and double-ended output shafts for maximum mounting flexibility. They can be easily mounted as clutches or brakes.	Natural	Tension unwind or rewind, soft start or stop, torque limiting	110–111
Low and medium torque units for light duty rewind applications. Shaft in–shaft out with pilots, allow for sample mounting. Optional brackets available.	Natural	Tension rewind, light duty rewind	112
This model has a hollow bore, making it ideal for applications where shaft mounting is preferred. It has a piloted input flange for pulley or sprocket attachment.	Self-cooling with integral fan	Tension rewind, soft start	113
This model is preferred in many applications. It is offered with male input and output shafts and all units are pilot mounted, except for the size 80. This largest unit, the size 80, is footmounted.	Natural	Tension rewind	114–115

# Magnetic Particle Brakes and Clutches

## Mechanical and Electrical Data (24 VDC)

Model	Size	Torque lb.ft. (lb.in.)	Drag Torque lb.ft. (lb.in.)	Max. Speed RPM	Inertia lb.ft. <sup>2</sup> (lb.in. <sup>2</sup> )	Resistance Ohms 75°F	Amperes 75°F	Max. Heat Diss. Watts @ Max. RPM	Weight lbs.
<b>MPB</b>	2	(2)	(.40)	1800	(1.31 x 10 <sup>-3</sup> )	303	0.079	10	1
	15	(15)	(.40)	1000	(1.39 x 10 <sup>-2</sup> )	80	0.302	20	3
	70	(70)	(1)	1000	(8.03 x 10 <sup>-2</sup> )	35	0.677	100	7
	120	(120)	(2)	1000	(3.75 x 10 <sup>-1</sup> )	33	0.742	140	12
	240	(240)	(4)	1000	(1.35)	14	1.693	200	20
<b>POB</b>	0.3	2.1	.065	1800	.0128	35.6	.674	105	5.3
	0.6	4.3	.13	1800	.0173	21.1	1.14	80	7.5
	40	289	8.7	1800	5.93	5.1	4.66	1990	176
	80	578	17	1500	23.5	4.3	5.57	3900	573
<b>PRB-H</b>	1.2	8.6	.26	1800	.104	31.6	.760	95	11
	2.5	18	.54	1800	.161	25.6	.937	118	15
	5	36	1.1	1800	.453	19.3	1.24	170	29
	10	72	2.2	1800	1.51	14.8	1.62	355	57
	20	144	4.3	1800	4.46	12.5	1.93	570	101
<b>PRB-HF</b>	1.2	8.6	.26	1800	.104	31.6	.760	112	11
	2.5	18	.54	1800	.161	25.6	.937	156	18
	5	36	1.1	1800	.453	19.3	1.24	235	31
	10	72	2.2	1800	1.51	14.8	1.62	435	62
	20	144	4.3	1800	4.46	12.5	1.93	745	108
<b>PRB-S</b>	1.2	8.6	.26	1800	.106	31.6	.760	106	13
	2.5	18	.54	1800	.164	25.6	.937	136	20
	5	36	1.1	1800	.458	19.3	1.24	195	38
	10	72	2.2	1800	1.52	14.8	1.62	385	73
	20	144	4.3	1800	4.51	12.5	1.93	660	124
<b>PRB-SF</b>	1.2	8.6	.26	1800	.106	31.6	.760	124	13
	2.5	18	.54	1800	.164	25.6	.937	180	22
	5	36	1.1	1800	.458	19.3	1.24	295	40
	10	72	2.2	1800	1.52	14.8	1.62	465	77
	20	144	4.3	1800	4.51	12.5	1.93	800	132
<b>PTB</b>	2.5	18	.54	1800	.0973	15.8	1.52	880	24
	5	36	1.1	1800	.249	8.8	2.74	1850	38
	10	72	2.2	1800	1.04	9.0	2.68	3050	76
	20	144	4.3	1800	2.23	7.20	3.34	4400	114
<b>PMC-A3</b>	10	(8.6)	(.25)	1800	.239	35.1	.684	30	2
	20	(17)	(.51)	1800	.413	31.6	.760	40	2.9
	40	(34)	(1)	1800	1.14	26.3	.912	68	5.5
<b>MPC</b>	2	(2)	(.40)	1800	(1.33 x 10 <sup>-3</sup> )	303	0.079	10	1
	15	(15)	(.40)	1000	(1.48 x 10 <sup>-2</sup> )	80	0.302	20	6
	70	(70)	(1)	1000	(8.89 x 10 <sup>-2</sup> )	35	0.677	100	17
	120	(120)	(2)	1000	(3.62 X 10 <sup>-1</sup> )	33	0.742	140	22
<b>PHC-R</b>	0.6	4.3	.13	1800	.0223	21.1	1.14	105	9.3
	1.2	8.6	.26	1800	.0392	20.6	1.16	200	13
	2.5	18	.54	1800	.126	15.8	1.52	395	22
	5	36	1.1	1800	.323	8.8	2.74	620	38
	10	72	2.2	1500	1.42	9.0	2.68	940	95
	20	144	4.3	1500	3.01	7.20	3.34	1350	154
<b>POC</b>	0.3	2.1	.065	1800	.0128	35.6	.674	105	5.5
	0.6	4.3	.13	1800	.0173	21.1	1.14	80	7.9
	1.2	8.6	.26	1800	.0304	20.6	1.16	145	12
	2.5	18	.54	1800	.0973	15.8	1.52	195	22
	5	36	1.1	1800	.249	8.8	2.74	290	38
	10	72	2.2	1800	1.04	9.0	2.68	460	77
	20	144	4.3	1800	2.23	7.2	3.34	790	128
	40	289	8.7	1800	5.93	5.1	4.66	1990	220
	80	578	17	1800	23.5	4.3	5.57	3900	551

# Magnetic Particle Brakes and Clutches

## Selection Requirements

### Torque

The torque required is calculated differently for different applications. For tension applications, torque is a function of roll radius and tension. For controlled starting and stopping, torque is a function of inertia, speed, and desired time to start or stop the load. For torque limiting applications, allowable drive through torque is used to select a unit. Please follow the selection example that applies to your application to determine the torque required in units of pound-feet.

### Heat

When a brake or clutch is slipping, heat is generated. This is the result of mechanical energy being converted to thermal energy. Tension applications are considered continuous slip applications. Heat generated is a function of tension and linear material speed and is generally described in terms of "thermal horsepower" (HPt). For starting and stopping applications, heat is generated when the unit slips during the stopping and starting of the load. Here heat is a function of speed, inertia, and cycle rate, and is described in terms "energy rate" (ft. lbs./min.). The selection example that fits your application will determine heat in the appropriate units.

The amount of energy the application produces must be less than the capabilities of the clutch or brake to dissipate. If the energy generated by the application is greater, then the controlling device will be destroyed from excessive heat buildup.

Environmental considerations such as -25°F to +140°F (-31.7°C to +60°C) high ambient temperature can reduce the unit's ability to dissipate heat. For applications with high ambient temperatures or where heat dissipation is marginal, fans or blowers may be used to improve dissipation.

## Heat Dissipation Curves

Determine your slip RPM requirements and torque requirements. Where the two points intersect must be under the curve for the unit selected. Remember to check at both minimum and maximum torque-speed conditions.

### MPC/MPB Clutches/Brakes

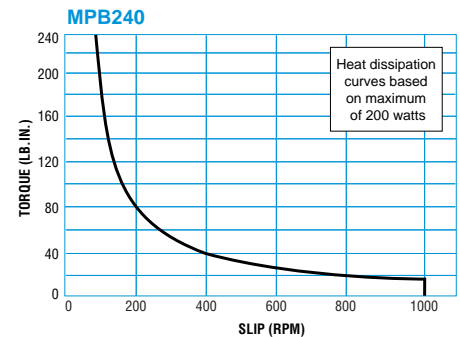
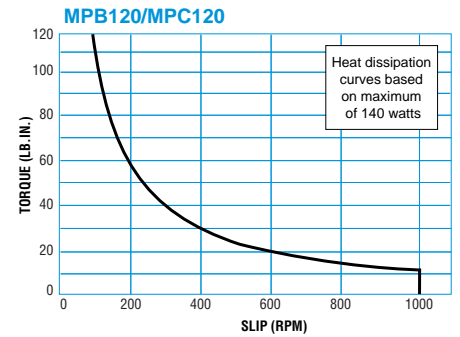
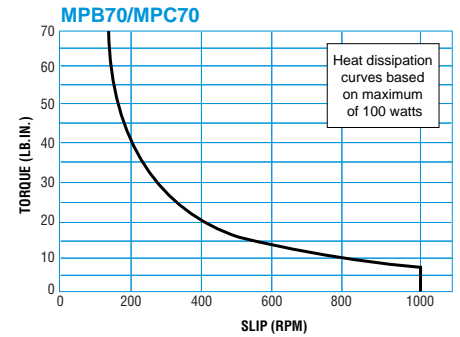
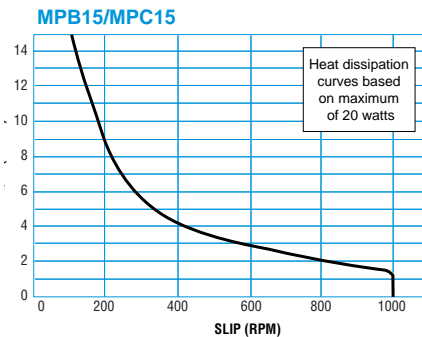
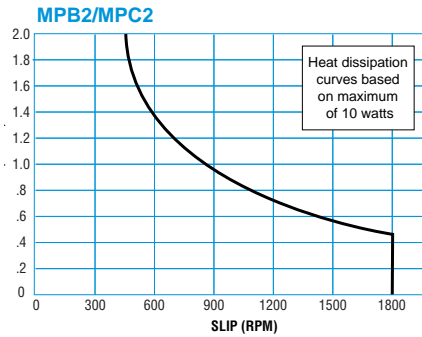



# Magnetic Particle Brakes and Clutches

## Heat Dissipation Curves

### Operating Temperature

The surface temperature of the unit must be less than the temperature indicated in the following chart.

### Maximum Surface Temperature

Model	Temp (°F)
PMC-A3	167
POC/PHC-R/POB	176
PRB/PTB-BL3	194

### PHC-R Clutches

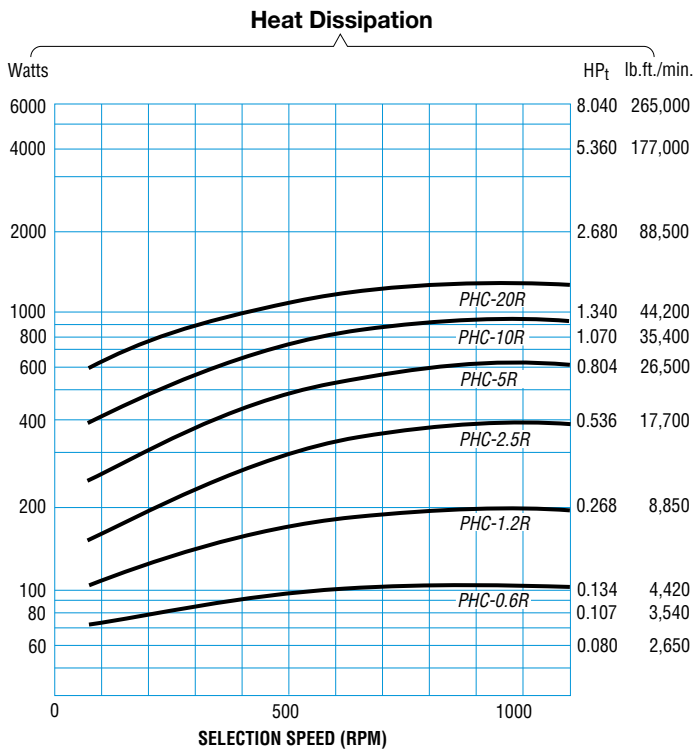

### PMC-A3 Clutches or Brakes

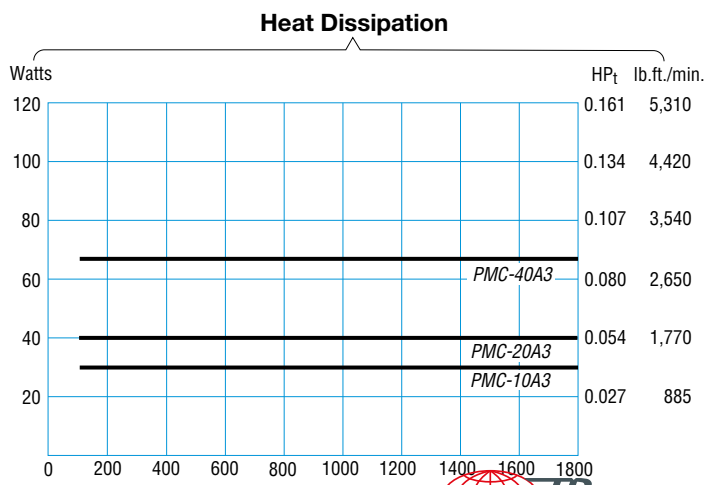

### POC/POB Clutches/Brakes

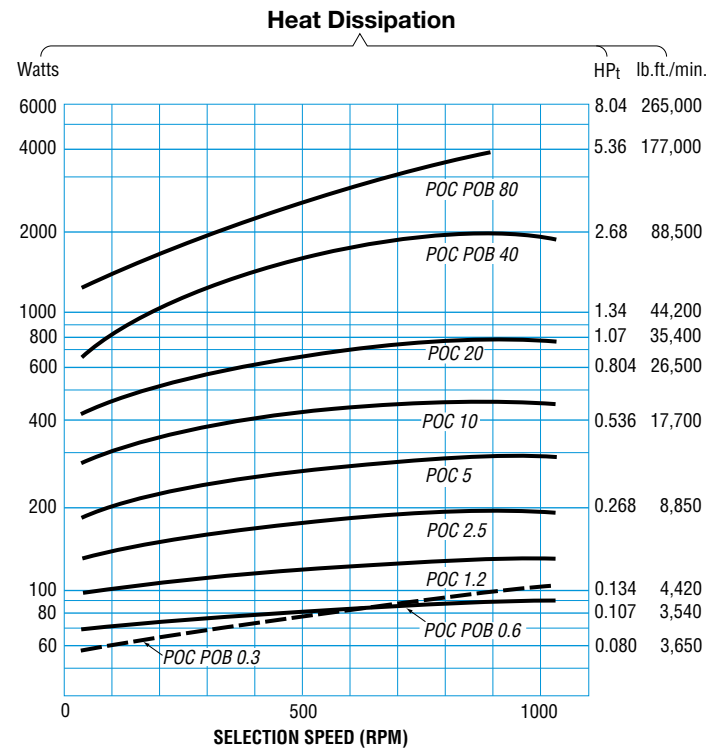

### PTB-BL3 Brakes

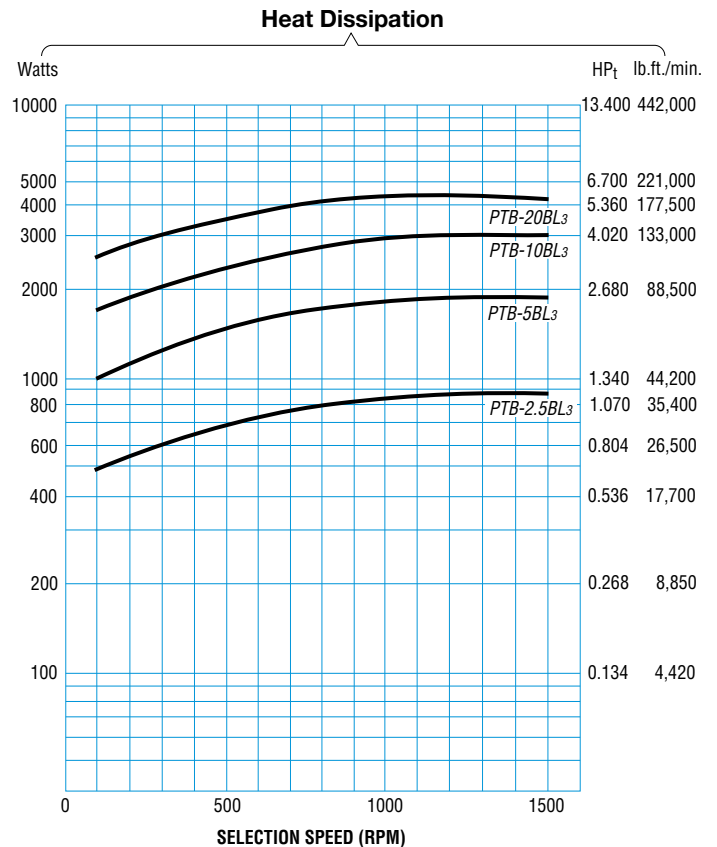

# Magnetic Particle Brakes and Clutches

## PRB-1.2H, S, HF, SF Brakes

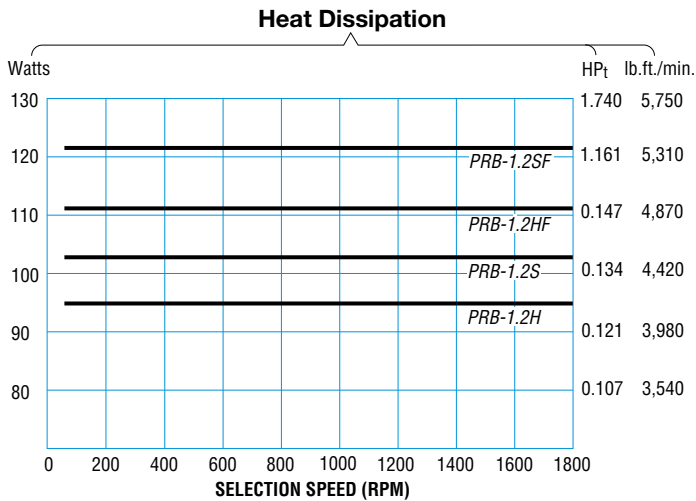

## PRB-5H, S, HF, SF Brakes

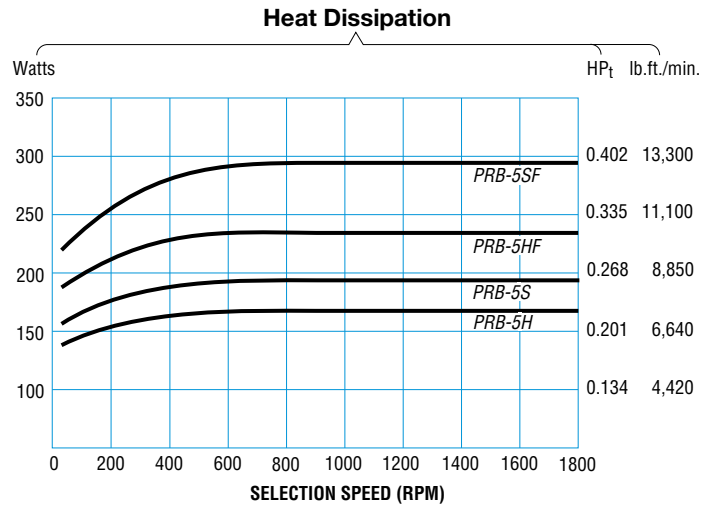

## PRB-2.5H, S, HF, SF Brakes

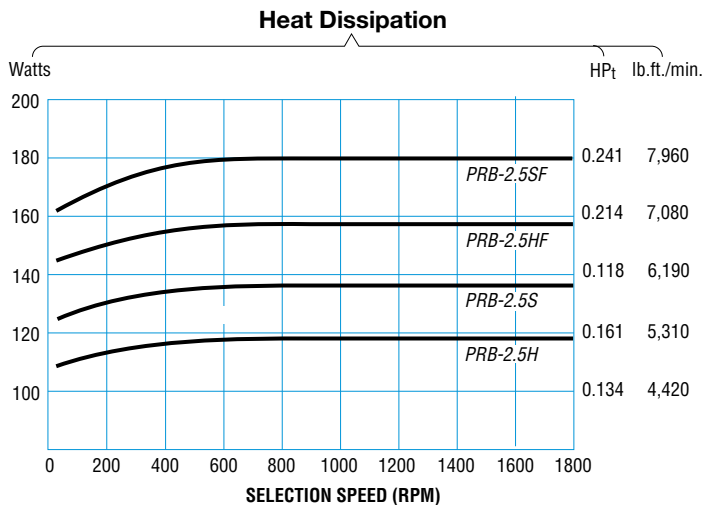

## PRB-10H, S, HF, SF Brakes

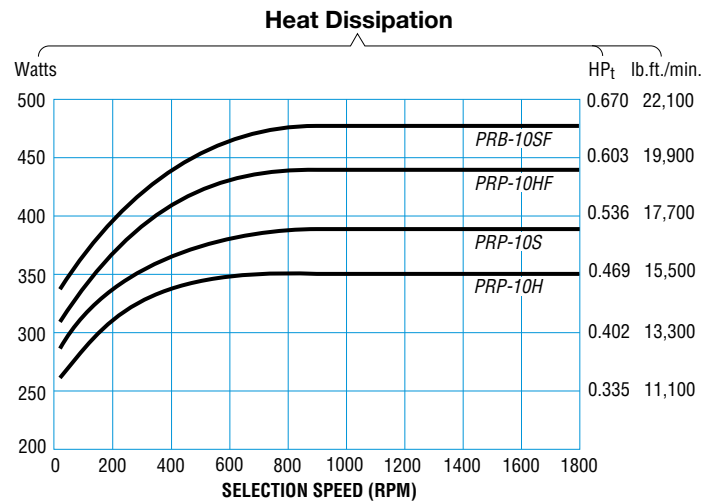

## PRB-20H, S, HF, SF Brakes

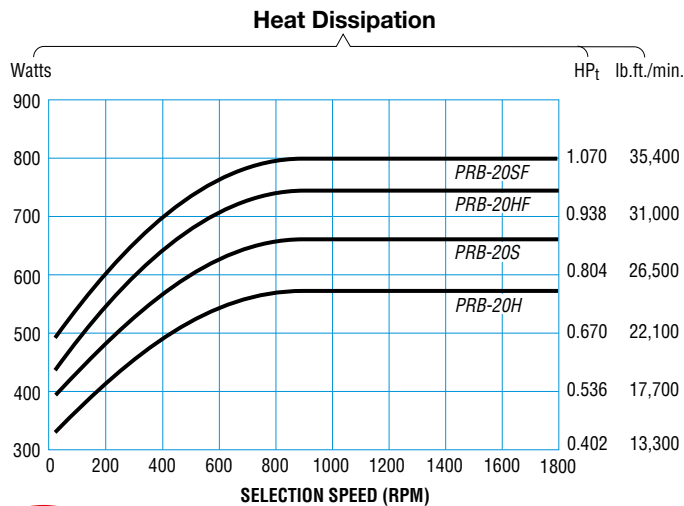

# MPB Series Brakes

Low and high torque units. Light duty thermal. All brakes have output shafts and pilots for mounting. Optional brackets available.

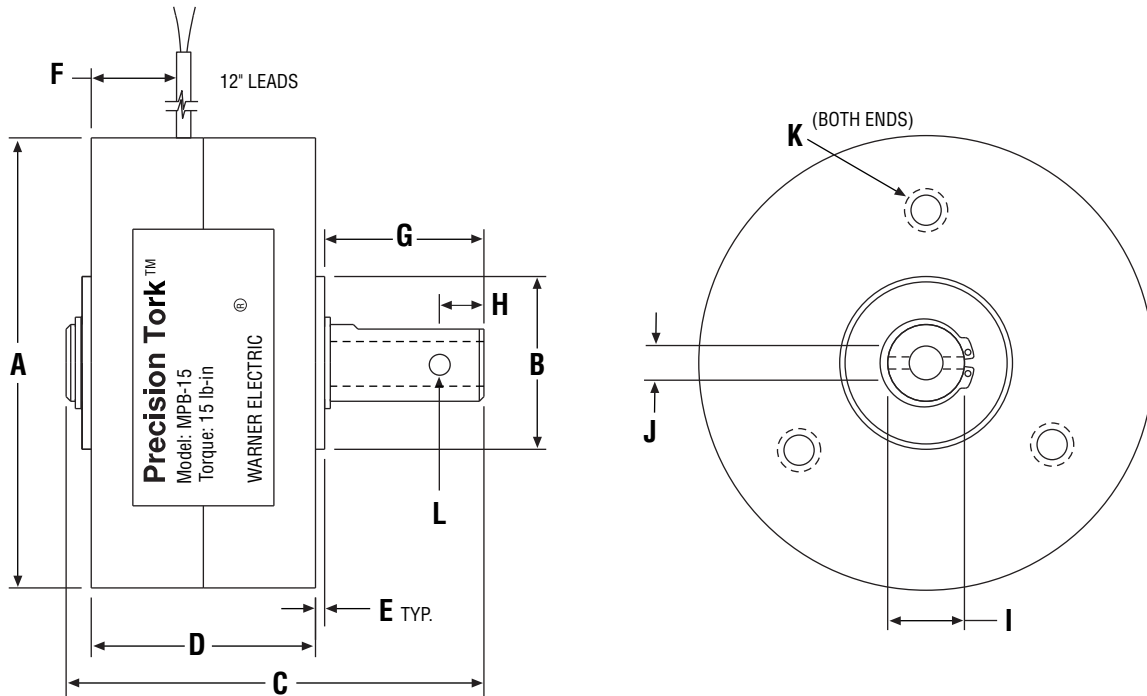

Optional mounting bracket, see page 116.

## Dimensions inches (mm)

Model	A	B	C	D	E	F	G	H	I (Shaft)	J (Bore)	K	L
MPB2-1	2.11	0.750/0.749	2.23	1.15	0.06	0.72	0.88	—	0.2947/0.2492	—	(3) #6-32 on 1.350 BC	1 Flat
MPB15-1	2.93	1.125/1.124	3.05	1.46	0.07	0.86	1.35	—	0.3747/0.3742	—	(3) #8-32 on 2.000 BC	1 Flat
MPB15-2	2.93	1.125/1.124	2.05	1.46	0.07	0.86	0.35	0.18	—	0.375/0.376	(3) #8-32 on 2.000 BC	0.125 Thru Hole
MPB15-3	2.93	1.125/1.124	2.70	1.46	0.07	0.86	1.00	—	0.4997/0.4992	—	(3) #8-32 on 2.000 BC	1 Flat
MPB70-1	4.48	1.625/1.624	2.62	1.76	0.10	0.98	0.50	0.18	—	0.500/0.501	(4) #10-32 on 4.228 BC	0.125 Thru Hole
MPB70-2	4.48	1.625/1.624	3.37	1.76	0.10	0.98	1.25	—	0.7497/0.7492	—	(4) #10-32 on 4.228 BC	0.188 Keyway
MPB120-1	5.25	1.625/1.624	4.02	2.17	0.10	1.18	1.50	0.50	—	0.500/0.501	(4) #1/4-20 on 4.812 BC	0.156 Thru Hole
MPB120-2	5.25	1.625/1.624	4.02	2.17	0.10	1.18	1.50	—	0.7497/0.7492	—	(4) #1/4-20 on 4.812 BC	0.188 Keyway
MPB240-1	6.21	2.441/2.440	4.66	2.65	0.10	1.46	1.65	—	0.7497/0.7492	—	(4) #1/4-20 on 5.875 BC	0.188 Keyway
MPB240-2	6.21	2.441/2.440	3.51	2.65	0.10	1.46	0.50	—	—	0.875/0.876	(4) #1/4-20 on 5.875 BC	0.188 Keyway
MPB240-3	6.21	2.441/2.440	3.51	2.65	0.10	1.46	0.50	—	—	1.000/1.001	(4) #1/4-20 on 5.875 BC	0.250 Shallow Keyway

## Specifications

Model Number	Max. Drag Torque 0 Excit. (lb.-in.)	Rated Torque (lb.-in.)	Rated Voltage	Resistance (Ohms)	Rated Current (Amps)	Build Up Time		Inertia of Output Shaft (lb.-in. <sup>2</sup> )	Max. Heat Dissipation (watts)	Max. Speed Recom. (RPM)	Weight
						W/out OEX (Millisec)	With OEX (Millisecs)				
MPB2	0.40	2	24	303	0.079	8	4	$1.31 \times 10^{-3}$	10	1,800	1
	0.40	2	90	1,539	0.058	8	4	$1.31 \times 10^{-3}$	10	1,800	1
MPB15	0.40	15	24	89	0.302	25	9	$1.39 \times 10^{-2}$	20	1,000	3
	0.40	15	90	1,501	0.060	25	9	$1.39 \times 10^{-2}$	20	1,000	3
MPB70	1.00	70	24	35	0.677	70	17	$8.03 \times 10^{-2}$	100	1,000	7
	1.00	70	90	613	0.147	70	17	$8.03 \times 10^{-2}$	100	1,000	7
MPB120	2.00	120	24	33	0.742	90	25	$3.75 \times 10^{-1}$	140	1,000	12
	2.00	120	90	475	0.190	90	25	$3.75 \times 10^{-1}$	140	1,000	12
MPB240	4.00	240	24	14	1.693	150	45	1.35	200	1,000	20
	4.00	240	90	186	0.485	150	45	1.35	200	1,000	20

All dimensions are nominal unless otherwise specified.  MEX (55) 53 63 23 31 MTY (81) 83 54 10 18  
 QRO (442) 1 95 72 60 ventas@industrialmagza.com

The PTB-BL3 offers superior heat dissipation capability. Units are pilot mounted and a male input shaft is provided for connecting to the load.

## Dimensions

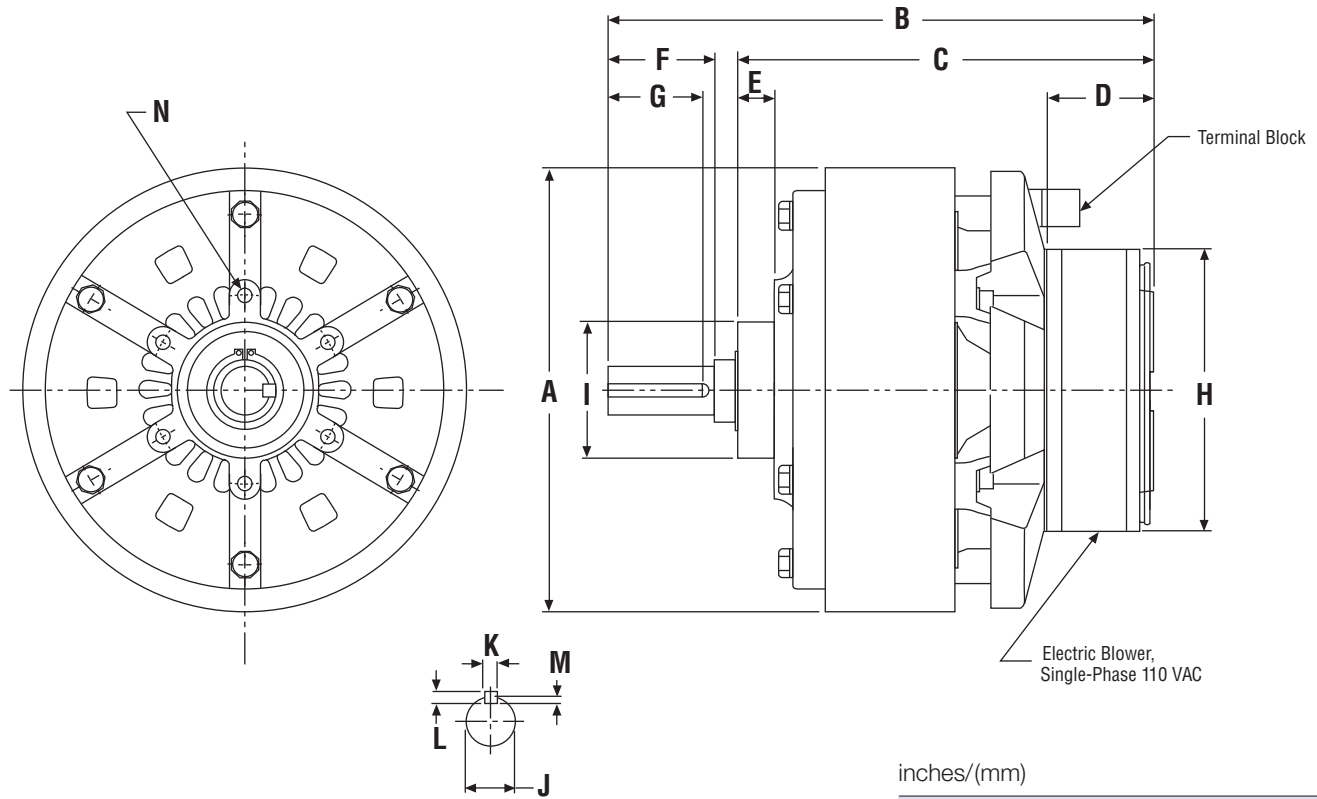

inches/(mm)

Shaft Dimensions				
Size	J	K	L	M
2.5	0.7874/0.7866 (20.000/19.979)	0.1978/0.1973 (5.024/5.012)	0.20 (5)	0.12 (3)
5	0.9843/0.9834 (25.000/24.979)	0.2768/0.2762 (7.030/7.015)	0.28 (7)	0.16 (4)
10	1.1811/1.1803 (30.000/29.979)	0.2768/0.2762 (7.030/7.015)	0.28 (7)	0.16 (4)
20	1.3780/1.3770 (35.000/34.975)	0.3949/0.3943 (10.030/10.015)	0.31 (8)	0.18 (4.5)

## Specifications

Model	Nominal Part Number	Torque (lb. ft.)	E-Stop Torque (lb. ft.)	Nominal Drag Torque (lb. ft.)	Maximum Speed (rpm)	Inertia Input (lb. ft. <sup>2</sup> )	Max. Heat Diss. Watts @ Max. RPM	Weight (lbs.)
2.5	5401-169-141	18	23	.54	1,800	.0973	880	24
5	5401-169-151	36	47	1.1	1,800	.249	1,850	38
10	5401-169-161	72	88	2.2	1,800	1.04	3,050	76
20	5401-169-171	144	180	4.3	1,800	2.23	4,400	114

**Note:** All dimensions are nominal unless otherwise noted.

inches/(mm)

Size	A	B	C	D	E	F	G	H*	I	N		
										Thread Size	Depth	Bolt Circle
2.5	7.17 (182)	8.72 (221.5)	6.67 (169.5)	1.69 (43)	0.59 (15)	1.69 (43)	1.50 (38)	□ 4.72 □ (120)	2.1654/2.1642 (55.000/54.970)	M6	0.51 (13)	3.071 (78)
5	8.62 (219)	10.81 (274.5)	8.19 (208)	2.42 (61.5)	0.91 (23)	2.24 (57)	1.85 (47)	○ 5.91 ○ (150)	2.9134/2.9122 (74.000/73.970)	M6	0.51 (13)	3.937 (100)
10	11.42 (290)	13.19 (335)	10.12 (257)	2.42 (61.5)	0.98 (25)	2.64 (67)	2.20 (56)	○ 5.91 ○ (150)	3.9370/3.9356 (100.000/99.965)	M10	0.71 (18)	5.512 (140)
20	13.19 (335)	13.88 (352.5)	10.61 (269.5)	2.42 (61.5)	0.98 (25)	2.80 (71)	2.36 (60)	○ 5.91 ○ (150)	4.3307/4.3293 (110.000/109.965)	M10	0.71 (18)	5.906 (150)

\*Adjacent symbol denotes shape of blower.

# POB Series Brakes

Low and high torque units are offered in this model. All units have male input shafts and pilots for mounting, except for the size 80, which is foot-mounted.

## Dimensions

### Sizes 0.3, 0.6 and 40

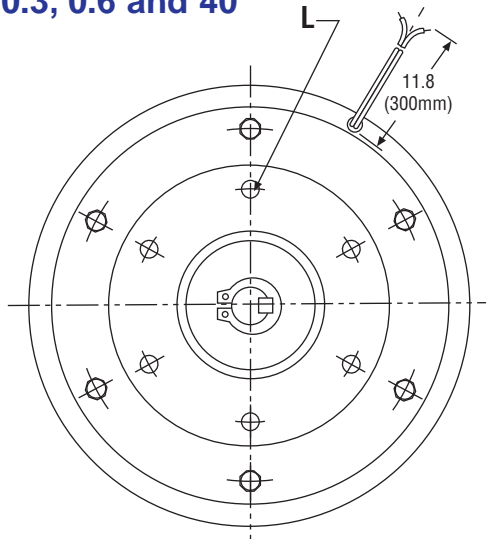

End View (POB-0.3 and POB-0.6)

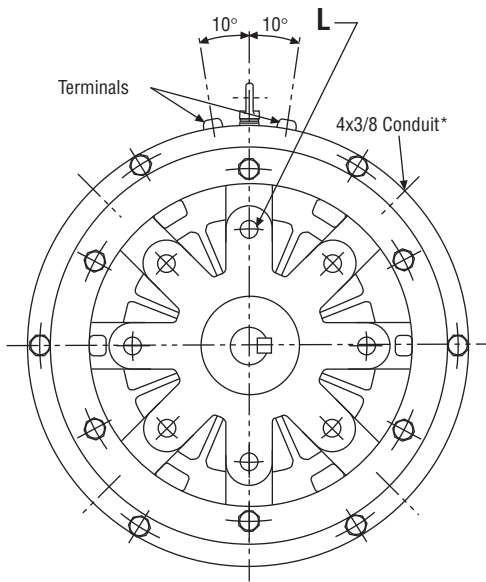

End View (POB-40)

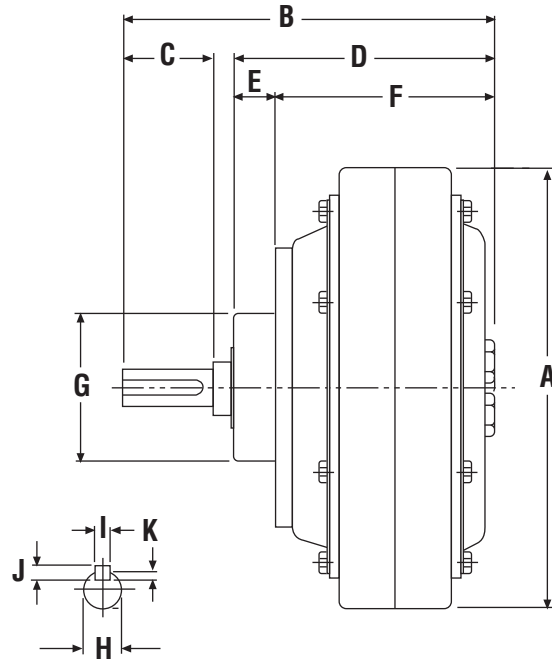

inches/(mm)

Size	Shaft Dimensions			
	H	I	J	K
0.3	0.3937/0.3931 (10.000/9.985)	0.1584/0.1580 (4.024/4.012)	0.16 (4)	0.10 (2.5)
0.6	0.4724/0.4717 (12.000/11.982)	0.1584/0.1580 (4.024/4.012)	0.16 (4)	0.10 (2.5)
40	1.7717/1.7707 (45.000/44.975)	0.4739/0.4731 (12.036/12.018)	0.31 (8)	0.18 (4.5)

inches/(mm)

Size	A	B	C	D	E	F	G	L			
								Thread Size	Depth	No. of Holes	Bolt Circle
0.3	4.72 (120)	4.13 (105)	0.91 (23)	2.95 (75)	0.43 (11)	2.52 (65)	1.6535/1.6526 (42.000/41.975)	M5	0.39 (10)	6	2.520 (64)
0.6	5.28 (134)	4.29 (109)	1.02 (26)	3.01 (76.5)	0.39 (10)	2.62 (66.5)	1.6535/1.6526 (42.000/41.975)	M5	0.43 (11)	6	2.520 (64)
40	15.55 (395)	12.99 (330)	3.62 (92)	8.82 (224)	1.30 (33)	7.52 (191)	5.1181/5.1165 (130.000/129.960)	M12	.79 (20)	8	2.520 (64)

\*Air inlet for optional forced air cooling. Consult factory.

## Size 80

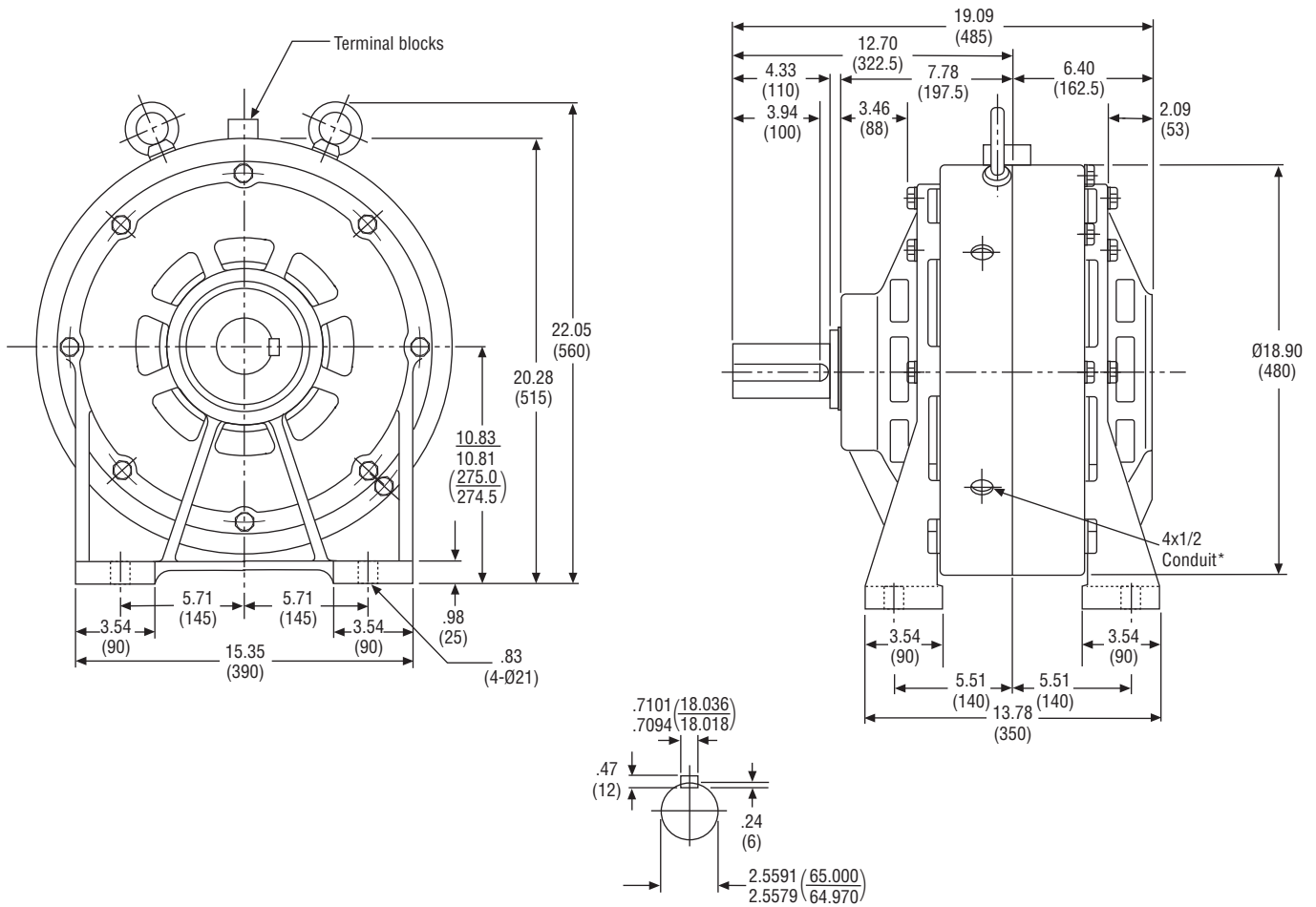

## Specifications

Size	Part Number	Rated Torque (lb. ft.)	E-Stop Torque (lb. ft.)	Drag Torque (lb. ft.)	Maximum Speed (rpm)	Inertia Input (lb. ft. <sup>2</sup> )	Max. Heat Diss. Watts @ Max. RPM	Weight (lbs.)
0.3	5401-169-211	2.1	3.0	.065	1,800	.0128	105	5.3
0.6	5401-169-221	4.3	5.9	.13	1,800	.0173	80	7.5
40	5401-169-281	289	361	8.7	1,800	5.93	1,990	176
80	5401-169-291	578	723	17	1,500	23.5	3,900	573

**Note:** All dimensions are nominal unless otherwise noted.

# PRB-H Series Brakes

This is the basic PRB model. It is offered with a hollow bore and a pilot for mounting.

## Dimensions

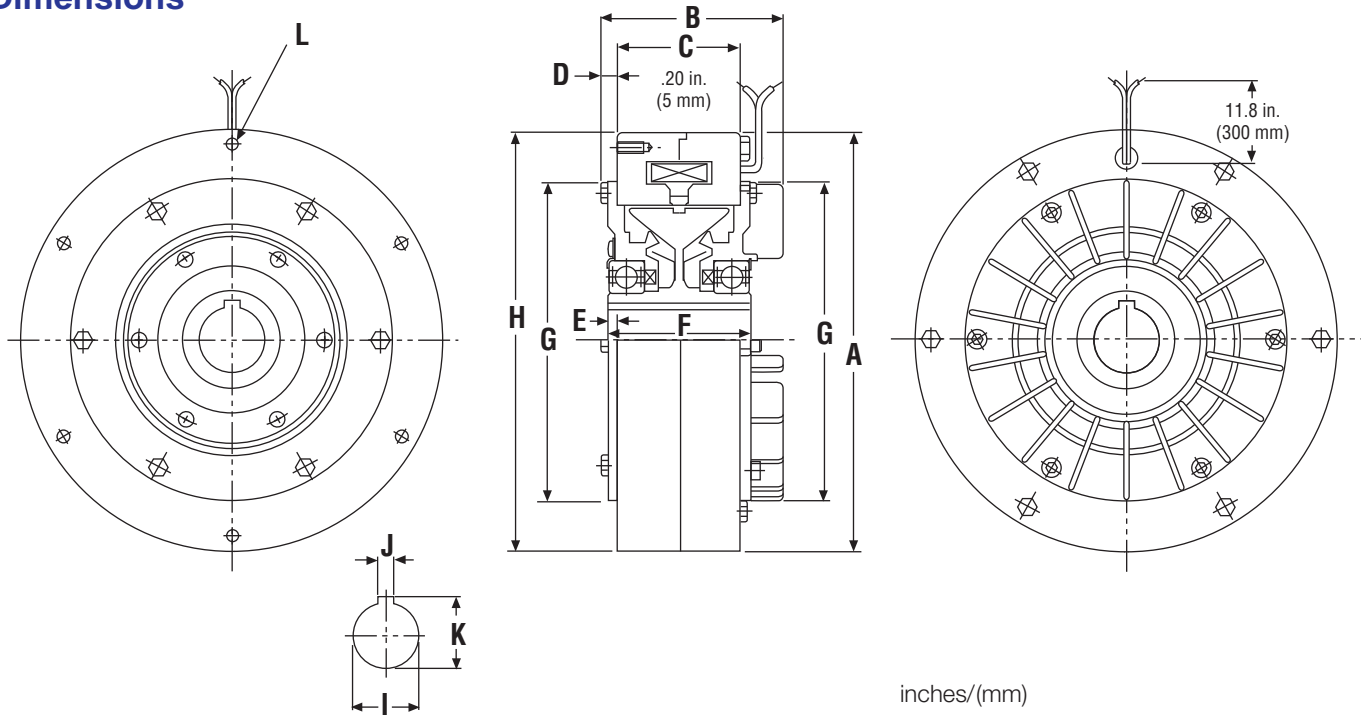

inches/(mm)

Bore Sizes			
Size	I	J	K
1.2	0.5913/0.5906 (15.018/15.000*)	0.1980/0.1972 (5.028/5.010)	0.6791/0.6693 (17.250/17.000)
2.5	0.7882/0.7874 (20.021/20.000*)	0.1980/0.1972 (5.028/5.010)	0.8760/0.8661 (22.250/22.000)
5	1.1819/1.1811 (30.021/30.000*)	0.2770/0.2761 (7.035/7.013)	1.3091/1.2992 (33.250/33.000)
10	1.1819/1.1811 (30.021/30.000)	0.2770/0.2761 (7.035/7.013)	1.3091/1.2992 (33.250/33.000)
20	1.5758/1.5748 (40.025/40.000)	0.3951/0.3942 (10.035/10.013)	1.7224/1.7126 (43.750/43.500)

## Specifications

Size	Part Number	Torque (lb. ft.)	E-Stop Torque (lb. ft.)	Drag Torque (lb. ft.)	Maximum Speed (rpm)	Inertia Input (lb. ft. <sup>2</sup> )	Max. Heat Diss. Watts @ Max. RPM	Weight (lbs.)
1.2	5401-169-331	8.6	12	.26	1,800	.104	95	11
2.5	5401-169-341	18	23	.54	1,800	.161	118	15
5	5401-169-351	36	43	1.1	1,800	.453	170	29
10	5401-169-361	72	101	2.2	1,800	1.51	355	57
20	5401-169-371	144	180	4.3	1,800	4.46	570	101

**Note:** All dimensions are nominal unless otherwise noted.

\* For availability of inch series bores, contact your Warner Electric representative.

inches/(mm)

Size	A	B	C	D	E	F	G	H	L			
									Thread Size	No. of Depth	Bolt Holes	Circle
1.2	5.35 (136)	2.48 (63)	1.65 (42)	0.28 (7)	0.22 (5.5)	2.09 (53)	4.29 (109)	5.3543/5.3528 (136.000/135.960)	M5	0.39 (10)	6	4.92 (125)
2.5	6.30 (160)	2.87 (73)	1.85 (47)	0.30 (6.5)	0.26 (6.5)	2.36 (60)	4.88 (124)	6.2992/6.2976 (160.000/159.960)	M5	0.39 (10)	6	5.83 (148)
5	7.68 (195)	3.33 (84.5)	2.24 (57)	0.31 (8)	0.20 (5)	2.64 (67)	5.87 (149)	7.6772/7.6754 (195.000/194.954)	M6	0.47 (12)	6	7.13 (181)
10	9.84 (250)	4.09 (104)	2.68 (68)	0.33 (8.5)	0.20 (5)	3.07 (78)	7.40 (188)	9.8425/9.8407 (250.000/249.954)	M6	0.47 (12)	8	9.17 (233)
20	12.01 (305)	5.06 (128.5)	3.15 (80)	0.47 (12)	0.30 (7.5)	3.74 (95)	9.21 (234)	12.0079/12.0058 (305.000/304.948)	M8	0.47 (12)	8	11.10 (282)

Like the PRB-H, this model has a hollow bore and mounting pilot, but it also has a finned housing for increased heat dissipation.

## Dimensions

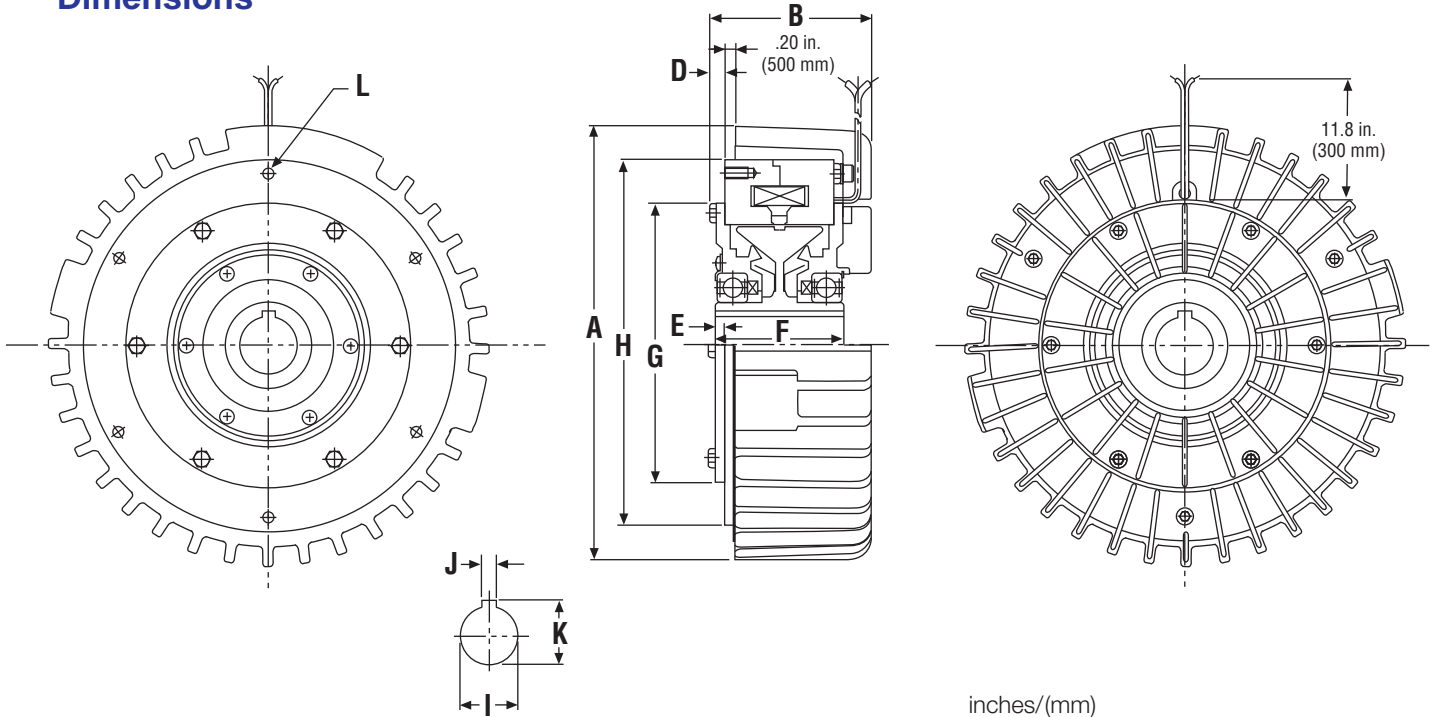

inches/(mm)

Bore Sizes			
Size	I	J	K
1.2	0.5913/0.5906 (15.018/15.000*)	0.1980/0.1972 (5.028/5.010)	0.6791/0.6693 (17.250/17.000)
2.5	0.7882/0.7874 (20.021/20.000*)	0.1980/0.1972 (5.028/5.010)	0.8760/0.8661 (22.250/22.000)
5	1.1819/1.1811 (30.021/30.000*)	0.2770/0.2761 (7.035/7.013)	1.3091/1.2992 (33.250/33.000)
10	1.1819/1.1811 (30.021/30.000)	0.2770/0.2761 (7.035/7.013)	1.3091/1.2992 (33.250/33.000)
20	1.5758/1.5748 (40.025/40.000)	0.3951/0.3942 (10.035/10.013)	1.7224/1.7126 (43.750/43.500)

## Specifications

Size	Part Number	Torque (lb. ft.)	E-Stop Torque (lb. ft.)	Drag Torque (lb. ft.)	Maximum Speed (rpm)	Inertia Input (lb. ft. <sup>2</sup> )	Max. Heat Diss. Watts @ Max. RPM	Weight (lbs.)
1.2	5401-169-431	8.6	12	.26	1,800	.104	112	11
2.5	5401-169-441	18	23	.54	1,800	.161	156	18
5	5401-169-451	36	43	1.1	1,800	.453	235	31
10	5401-169-461	72	101	2.2	1,800	1.51	435	62
20	5401-169-471	144	180	4.3	1,800	4.46	745	108

**Note:** All dimensions are nominal unless otherwise noted.

\* For availability of inch series bores, contact your Warner Electric representative.

inches (mm)

Size	A	B	D	E	F	G	H	L			
								Thread Size	Depth	No. of Holes	Bolt Circle
1.2	6.26 (159)	2.48 (63)	0.28 (7)	0.22 (5.5)	2.09 (53)	4.29 (109)	5.3543/5.3528 (136.000/135.960)	M5	0.39 (10)	6	4.92 (125)
2.5	7.44 (189)	2.87 (73)	0.30 (7.5)	0.26 (6.5)	2.36 (60)	4.88 (124)	6.2992/6.2976 (160.000/159.960)	M5	0.39 (10)	6	5.83 (148)
5	9.06 (230)	3.33 (84.5)	0.31 (8)	0.20 (5)	2.64 (67)	5.87 (149)	7.6772/7.7147 (195.000/195.954)	M6	0.47 (12)	6	7.13 (181)
10	11.67 (296.5)	4.09 (104)	0.33 (8.5)	0.20 (5)	3.07 (78)	7.40 (188)	9.8425/9.8407 (250.000/249.954)	M6	0.47 (12)	8	9.17 (233)
20	14.29 (363)	5.06 (128.5)	0.47 (12)	0.30 (7.5)	3.74 (95)	9.21 (234)	12.0079/12.0058 (305.000/304.948)	M8	0.47 (12)	8	11.10 (282)



# PRB-S Series Brakes

This model has a pilot for mounting, like the PRB-H. However, it has a male input shaft instead of a hollow bore.

## Dimensions

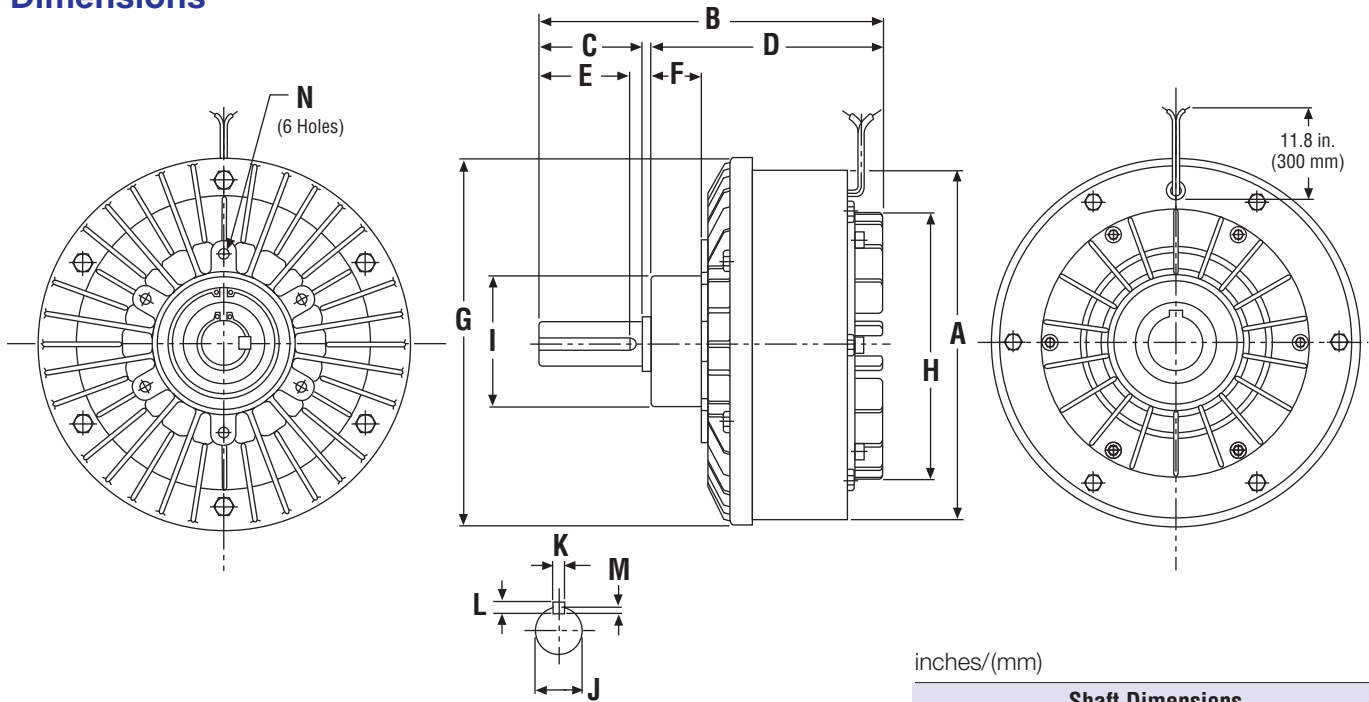

inches/(mm)

Shaft Dimensions				
Size	J	K	L	M
1.2	0.5906/0.5901 (15.000/14.988)	0.1978/0.1973 (5.024/5.012)	0.20 (5)	0.12 (3)
2.5	0.7874/0.7866 (20.000/19.979)	0.1978/0.1973 (5.024/5.012)	0.20 (5)	0.12 (3)
5	0.9843/0.9834 (25.000/24.979)	0.2768/0.2762 (7.030/7.015)	0.28 (7)	0.16 (4)
10	1.1811/1.1803 (30.000/29.979)	0.2768/0.2762 (7.030/7.015)	0.28 (7)	0.16 (4)
20	1.3780/1.3770 (35.000/34.975)	0.3949/0.3943 (10.030/10.015)	0.31 (8)	0.18 (4.5)

## Specifications

Model	Part Number	Torque (lb. ft.)	E-Stop Torque (lb. ft.)	Drag Torque (lb. ft.)	Maximum Speed (rpm)	Inertia Input (lb. ft. <sup>2</sup> )	Max. Heat Diss. Watts @ Max. RPM	Weight (lbs.)
1.2	5401-169-531	8.6	12	.26	1,800	.106	106	13
2.5	5401-169-541	18	23	.54	1,800	.164	136	20
5	5401-169-551	36	43	1.1	1,800	.458	195	38
10	5401-169-561	72	101	2.2	1,800	1.52	385	73
20	5401-169-571	144	180	4.3	1,800	4.51	660	124

**Note:** All dimensions are nominal unless otherwise noted.

inches (mm)

Size	A	B	C	D	E	F	G	H	I	N		
										Thread Size	Depth	Bolt Circle
1.2	5.35 (136)	5.14 (130.5)	1.36 (34.5)	3.68 (93.5)	1.18 (30)	0.67 (17)	5.71 (145)	4.29 (109)	1.6535/1.6526 (42.000/41.975)	M6	0.47 (12)	2.52 (64)
2.5	6.30 (160)	6.10 (155)	1.69 (43)	4.29 (109)	1.50 (38)	0.83 (21)	6.69 (170)	4.88 (124)	2.1654/2.1642 (55.00/54.970)	M6	0.51 (13)	3.07 (78)
5	7.68 (195)	7.44 (189)	2.24 (57)	5.02 (127.5)	1.97 (50)	1.10 (28)	8.15 (207)	5.87 (149)	2.9134/2.9122 (74.000/73.970)	M6	0.51 (13)	3.94 (100)
10	9.84 (250)	9.19 (233.5)	2.64 (67)	6.40 (162.5)	2.36 (60)	1.26 (32)	10.31 (262)	7.40 (188)	3.9370/3.9356 (100.000/99.965)	M10	0.71 (18)	5.51 (140)
20	12.01 (305)	10.37 (263.5)	2.80 (71)	7.38 (187.5)	2.36 (60)	1.26 (32)	12.56 (319)	9.21 (234)	4.3307/4.3293 (110.000/109.965)	M10	0.71 (18)	5.91 (150)

**Note:** This is a stationary field clutch. The tapped holes "L" in the field are for securing the housing to prevent it from rotating. See installation instructions. Do not block ventilation openings when mounting.

This version of the PRB has both the male input shaft and a finned housing, for increased heat dissipation. It also is pilot mounted.

## Dimensions

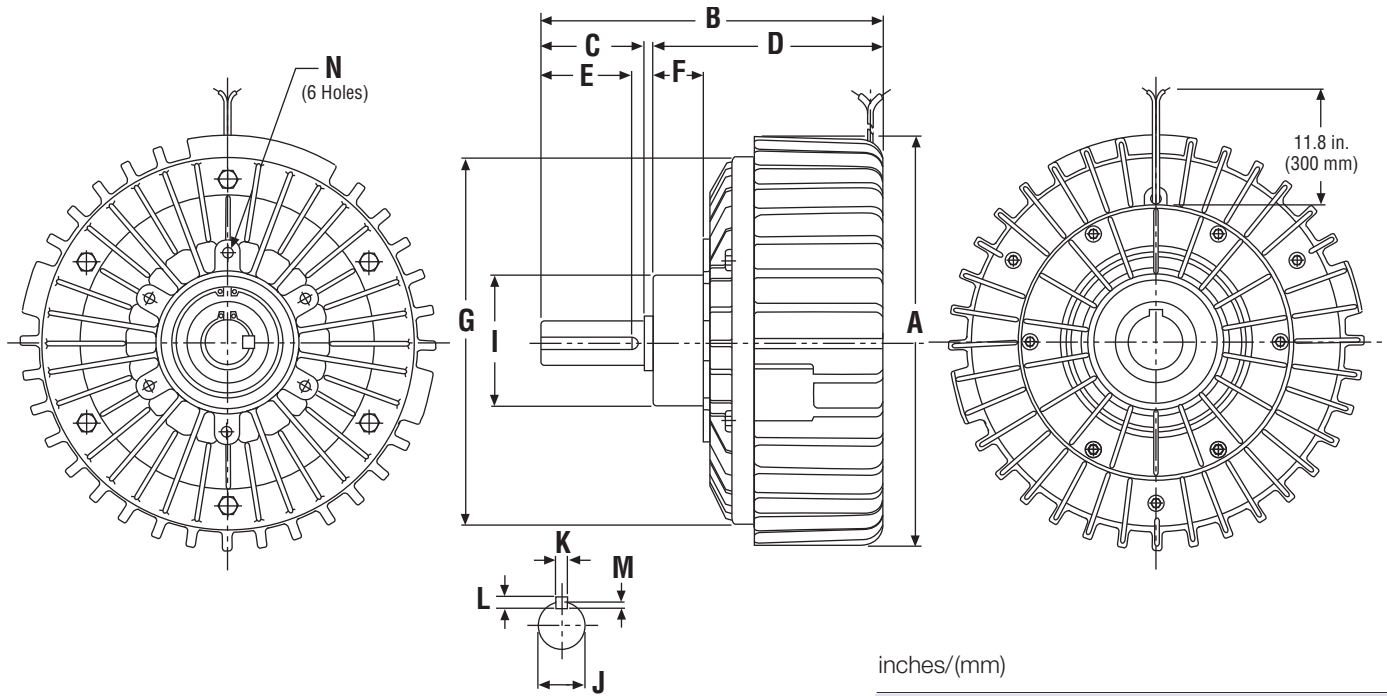

inches/(mm)

Shaft Dimensions				
Size	J	K	L	M
1.2	0.5906/0.5901 (15.000/14.988)	0.1978/0.1973 (5.024/5.012)	0.20 (5)	0.12 (3)
2.5	0.7874/0.7866 (20.000/19.979)	0.1978/0.1973 (5.024/5.012)	0.20 (5)	0.12 (3)
5	0.9843/0.9834 (25.000/24.979)	0.2768/0.2762 (7.030/7.015)	0.28 (7)	0.16 (4)
10	1.1811/1.1803 (30.000/29.979)	0.2768/0.2762 (7.030/7.015)	0.28 (7)	0.16 (4)
20	1.3780/1.3770 (35.000/34.975)	0.3949/0.3943 (10.030/10.015)	0.31 (8)	0.18 (4.5)

## Specifications

Model	Part Number	Torque (lb. ft.)	E-Stop Torque (lb. ft.)	Drag Torque (lb. ft.)	Maximum Speed (rpm)	Inertia Input (lb. ft. <sup>2</sup> )	Max. Heat Diss. Watts @ Max. RPM	Weight (lbs.)
1.2	5401-169-631	8.6	12	.26	1,800	.106	124	13
2.5	5401-169-641	18	23	.54	1,800	.164	180	22
5	5401-169-651	36	43	1.1	1,800	.458	295	40
10	5401-169-661	72	101	2.2	1,800	1.52	465	77
20	5401-169-671	144	180	4.3	1,800	4.51	800	132

**Note:** All dimensions are nominal unless otherwise noted.

inches/(mm)

Size	A	B	C	D	E	F	G	I	N		
									Thread Size	Depth	Bolt Circle
1.2	6.28 (159.5)	5.14 (130.5)	1.36 (34.5)	3.68 (93.5)	1.18 (30)	0.67 (17)	5.71 (145)	1.6535/1.6526 (42.000/41.975)	M6	0.47 (12)	2.52 (64)
2.5	7.44 (189)	6.10 (155)	1.69 (43)	4.29 (109)	1.50 (38)	0.83 (21)	6.69 (170)	2.1654/2.1642 (55.000/54.970)	M6	0.51 (13)	3.07 (78)
5	9.06 (230)	7.44 (189)	2.24 (57)	5.02 (127.5)	1.97 (50)	1.10 (28)	8.15 (207)	2.9134/2.9122 (74.000/73.970)	M6	0.51 (13)	3.94 (100)
10	11.67 (296.5)	9.19 (233.5)	2.64 (67)	6.40 (162.5)	2.36 (60)	1.26 (32)	10.31 (262)	3.9370/3.9356 (100.000/99.965)	M10	0.71 (18)	5.51 (140)
20	14.29 (363)	10.37 (263.5)	2.80 (71)	7.38 (187.5)	2.36 (60)	1.26 (32)	12.56 (319)	4.3307/4.3293 (110.000/109.965)	M10	0.71 (18)	5.91 (150)

# PMC Series Clutches/Brakes

These units offer precise control in the small tension ranges. They have flanged input hubs and double-ended output shafts for maximum mounting flexibility. They can be easily mounted as clutches or brakes.

## Dimensions Sizes 10 and 20

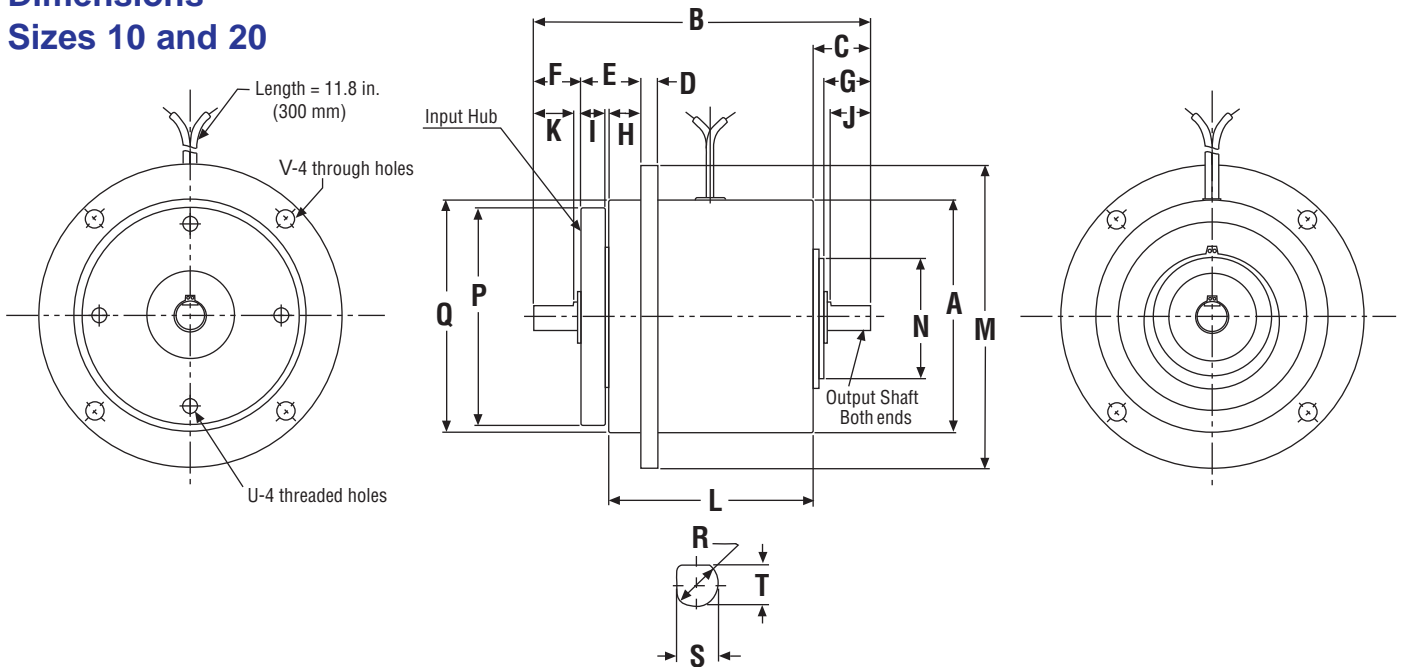

## Specifications

Size	Part Number	Torque (lb. in.)	E-Stop Torque (lb. in.)	Drag Torque (lb. in.)	Maximum Speed (rpm)	Inertia Input (lb. in. <sup>2</sup> )	Output (lb. in. <sup>2</sup> )	Max. Heat Diss. Watts @ Max. RPM	Weight (lbs.)
10	5401-270-111	8.6	11.5	.25	1,800	.239	.0291	30	2.0
20	5401-270-121	17	20.4	.51	1,800	.413	.0752	40	2.9

inches/(mm)

Size	A	B	C	D	E	F	G	H	I	J	K	L	M	N
10	2.28 (58)	3.03 (77)	0.55 (14)	0.16 (4)	0.59 (15)	0.47 (12)	0.47 (12)	0.31 (8)	0.24 (6)	0.39 (10)	0.39 (10)	2.01 (51)	2.99 (76)	1.18 (30)
20	2.72 (69)	4.57 (116)	1.30 (33)	0.16 (4)	0.87 (22)	0.98 (25)	0.94 (24)	0.59 (15)	0.24 (6)	0.79 (20)	0.79 (20)	2.01 (51)	3.62 (92)	1.38 (35)

Size	Shaft Dimensions					U		V		
	P	Q	R	S	T	Thread Size	Depth	Bolt Circle	Hole Size	Bolt Circle
10	2.1260/2.1248 (54.000/53.970)	2.2835/2.2823 (58.000/57.970)	0.2756/0.2750 (7.000/6.985)	0.24 (6)	— (—)	M4	0.24 (6)	1.81 (46)	0.18 (4.5)	2.68 (68)
20	2.1260/2.1248 (54.000/53.970)	2.7165/2.7154 (69.000/68.970)	0.4724/0.4720 (12.000/11.988)	0.45 (11.5)	0.45 (11.5)	M4	0.24 (6)	1.81 (46)	0.18 (4.5)	3.23 (82)

**Note:** All dimensions are nominal unless otherwise noted.

## Dimensions Size 40

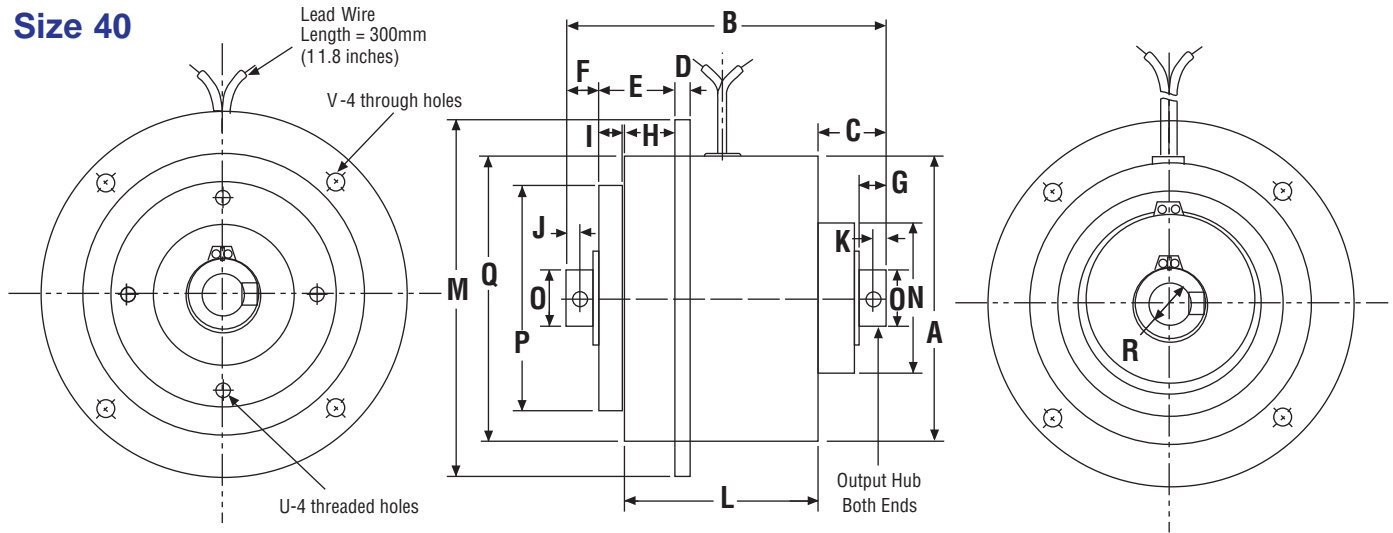

## Specifications

Size	Part Number	Torque (lb. in.)	E-Stop Torque (lb. in.)	Drag Torque (lb. in.)	Maximum Speed (rpm)	Inertia Input (lb. in. <sup>2</sup> )	Output (lb. in. <sup>2</sup> )	Max. Heat Diss. Watts @ Max. RPM	Weight (lbs.)
40	5401-270-131	34	42.5	1.0	1,800	1.14	.372	68	5.5

inches/(mm)

Size	A	B	C	D	E	F	G	H	I	J	K	L	M	N	O
40	3.39 (86)	3.82 (97)	0.83 (21)	0.16 (4)	0.87 (22)	0.39 (10)	0.34 (8.7)	0.59 (15)	0.24 (6)	0.16 (4)	0.16 (4)	2.32 (59)	4.41 (112)	1.97 (50)	0.79 (20)

Size	Bore			U		V		
	P	Q	R	Thread Size	Depth	Bolt Circle	Hole Size	Bolt Circle
40	2.7559/2.7547 (70.000/69.970)	3.3858/3.3844 (86.000/85.965)	0.4731/0.4724 (12.018/12.000)	M4	0.24 (6)	2.36 (60)	0.18 (4.5)	3.94 (100)

**Note:** All dimensions are nominal unless otherwise noted.

# MPC Series Clutches

Low and medium torque units for light duty rewind applications. Shaft in-shaft out with pilots, allow for sample mounting. Optional brackets available.

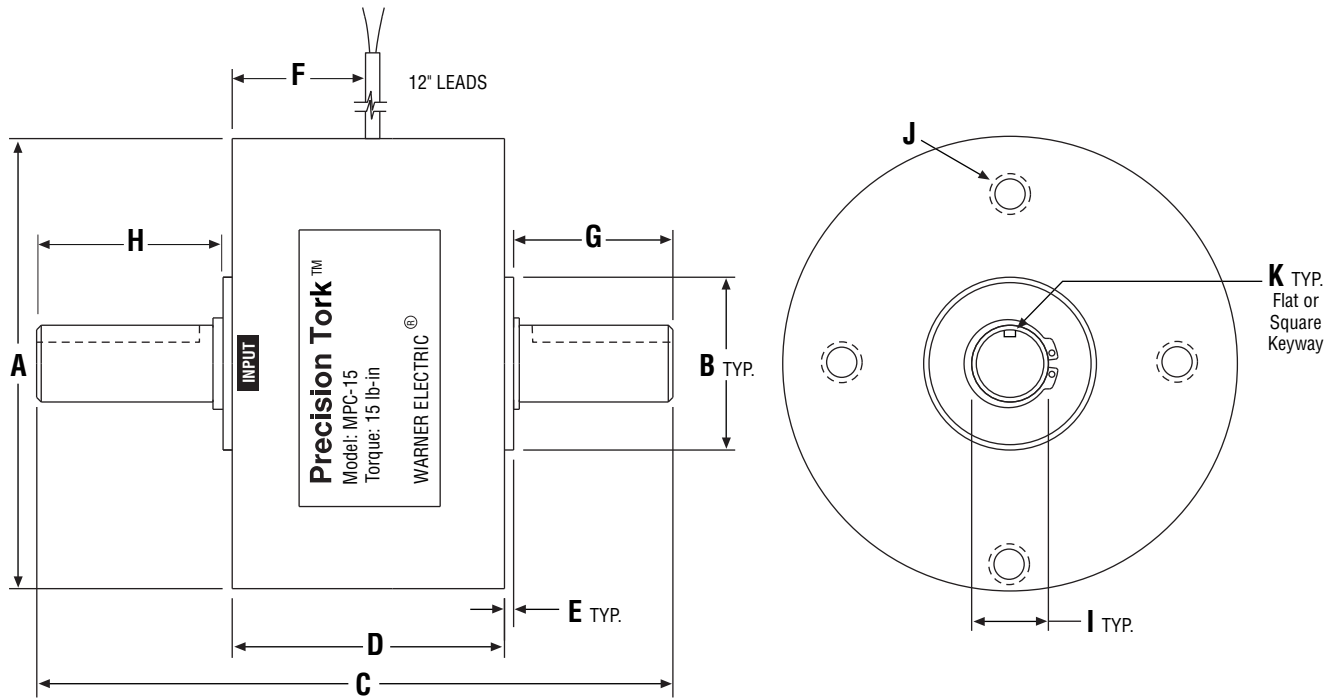

Optional mounting bracket, see page 116.

## Dimensions inches/(mm)

Model	A	B	C	D	E	F	G (Output)	H (Input)	I	J	K
MPC2	2.11	0.750/0.749	3.82	1.86	0.06	1.14	0.88	0.88	0.2497/0.2492	(3) #6-32 on 1.350 BC	Flat
MPC15	2.96	1.125/1.124	4.81	2.80	0.07	1.67	1.00	1.00	0.4997/0.4992	(3) #8-32 on 2.000 BC	Flat
MPC70	4.48	1.625/1.624	6.55	3.67	0.10	2.08	1.35	1.35	0.7497/0.7492	(4) #10-32 on 4.228 BC	0.188 Keyway
MPC120	5.25	1.625/1.624	7.02	4.00	0.10	2.40	1.50	1.35	0.7497/0.7492	(4) #1/4-20 on 4.812 BC	0.188 Keyway

## Specifications

Model Number	Max. Drag Torque		Rated Torque (lb.-in.)	Rated Voltage	Resistance (Ohms)	Rated Current (Amps)	Build Up Time		Inertia of Output Shaft (lb.-in. <sup>2</sup> )	Max. Heat Dissipation (watts)	Max. Speed Recom. (RPM)	Weight
	0 Excit. (lb.-in.)						W/out OEX (Millisec)	With OEX (Millisecs)				
MPC2	0.40	2	24	90	303	0.079	8	4	1.33 x 10 <sup>-3</sup>	10	1,800	1
	0.40	2										
MPC15	0.40	15	24	90	80	0.302	25	9	1.48 x 10 <sup>-2</sup>	20	1,000	6
	0.40	15										
MPC70	1.00	70	24	90	35	0.677	70	17	8.84 x 10 <sup>-2</sup>	100	1,000	17
	1.00	70										
MPC120	2.00	120	24	90	33	0.742	90	25	3.82 x 10 <sup>-1</sup>	140	1,000	22
	2.00	120										

All dimensions are nominal unless otherwise noted.

# PHC-R Series Clutches

This model has a hollow bore, making it ideal for applications where shaft mounting is preferred. It has a piloted input flange for pulley or sprocket attachment.

## Dimensions

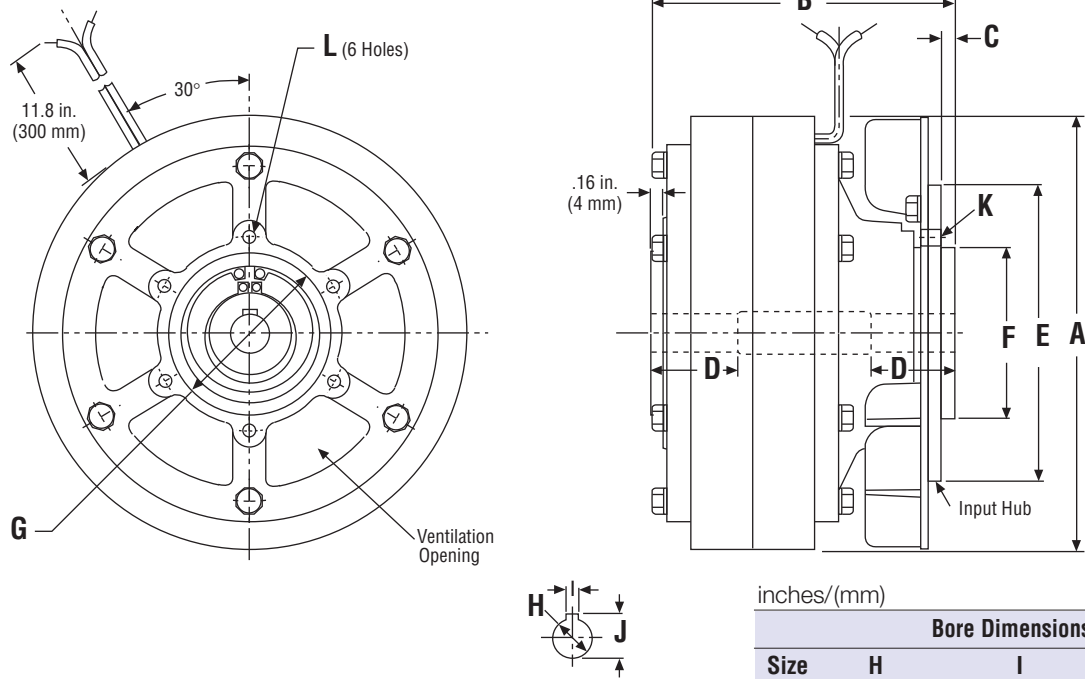

## Specifications

Size	Part Number	Nominal Torque (lb. ft.)	Nominal Drag Torque (lb. ft.)	Maximum Speed (rpm)	Inertia Input (lb. ft. <sup>2</sup> )	Output (lb. ft. <sup>2</sup> )	Max. Heat Diss. Watts @ Max. RPM	Weight (lbs.)
0.6	5401-270-321	4.3	.13	1,800	.0223	.00712	105	9.3
1.2	5401-270-331	8.6	.26	1,800	.0392	.0171	200	13
2.5	5401-270-341	18	.54	1,800	.126	.0494	395	22
5	5401-270-351	36	1.1	1,800	.323	.138	620	38
10	5401-270-361	72	2.2	1,500	1.42	.617	940	95
20	5401-270-371	144	4.3	1,500	3.01	1.30	1,350	154

inches/(mm)

Size	Bore Dimensions		
	H	I	J
0.6	0.4731/0.4724 (12.018/12.000)	0.1586/0.1579 (4.028/4.010)	0.5413/0.5315 (13.75/13.50)
1.2	0.5913/0.5906 (15.018/15.000)	0.1980/0.1972 (5.028/5.010)	0.6791/0.6693 (17.25/17.00)
2.5	0.9851/0.9843 (25.021/25.000)	0.2770/0.2761 (7.035/7.013)	1.1122/1.1024 (28.25/28.00)
5	1.3789/1.3780 (35.025/35.000)	0.3951/0.3942 (10.035/10.013)	1.5256/1.5157 (38.75/38.50)
10	1.7726/1.7717 (45.025/45.000)	0.4741/0.4731 (12.043/12.016)	1.9193/1.9094 (48.75/48.50)
20	2.1665/2.1654 (55.030/55.000)	0.5922/0.5912 (15.043/15.016)	2.3720/2.3622 (60.25/60.00)

**Note:** All dimensions are nominal unless otherwise noted.

inches/(mm)

Size	A	B	C	D	E	F	G	K			L		
								Thread Size	Depth	Bolt Circle	Thread Size	Depth	Bolt Circle
0.6	5.28 (134)	3.62 (92)	0.16 (4)	1.00 (25.5)	3.50 (89)	1.9685/1.9675 (50.000/49.975)	1.9685/1.9675 (50.000/49.975)	M4	0.24 (6)	2.362 (60)	M4	0.24 (6)	2.362 (60)
1.2	5.98 (152)	3.78 (96)	0.16 (4)	0.98 (25)	3.50 (89)	1.7717/1.7707 (45.000/44.975)	2.7559/2.7547 (70.000/69.970)	M5	0.24 (6)	2.165 (55)	M4	0.31 (8)	3.150 (80)
2.5	7.17 (182)	5.20 (132)	0.20 (5)	1.77 (45)	5.51 (140)	2.7559/2.7547 (70.000/69.970)	2.7559/2.7429 (70.000/69.670)	M6	0.39 (10)	3.150 (80)	M6	0.35 (9)	3.150 (80)
5	8.62 (219)	5.83 (148)	0.16 (4)	1.57 (40)	6.50 (165)	3.4252/3.4238 (87.000/86.965)	3.4252/3.4238 (87.000/86.965)	M8	0.39 (10)	4.016 (102)	M8	0.39 (10)	4.016 (102)
10	11.42 (290)	7.22 (183.5)	0.24 (6)	2.36 (60)	7.48 (190)	4.1339/4.1325 (105.000/104.965)	4.3307/4.3293 (110.000/109.965)	M10	0.51 (13)	5.512 (140)	M8	0.39 (10)	4.724 (120)
20	13.19 (335)	8.74 (222)	0.35 (9)	2.95 (75)	8.66 (220)	5.1181/5.1165 (130.000/129.960)	5.1181/5.1165 (130.000/129.960)	M10	0.59 (15)	5.906 (150)	M10	0.53 (13.5)	5.906 (150)

**Note:** This is a stationary field clutch. The tapped holes "L" in the field are for securing the housing to prevent it from rotating. This can be done with cap screws (see figure 3, page 32). Do not block ventilation openings when mounting.

# POC Series Clutches

This model is preferred in many applications. It is offered with male input and output shafts and all units are pilot mounted, except for the size 80. This largest unit, the size 80, is foot mounted.

## Dimensions Sizes 0.3 through 40

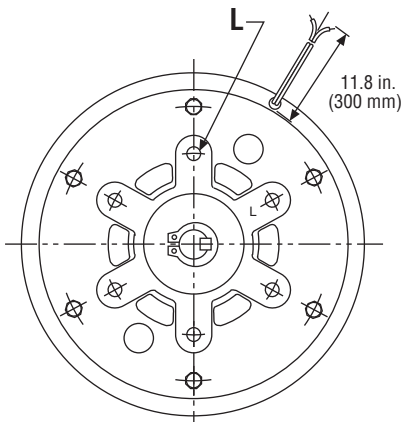

End View (Size 20 and smaller)

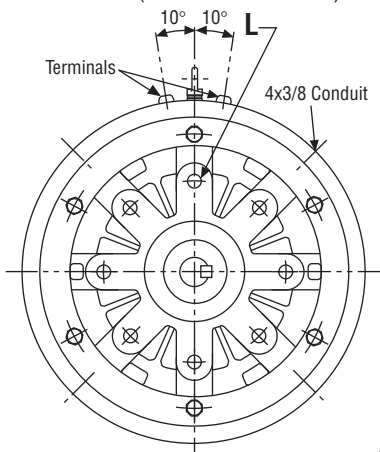

End View (POC-40)

All dimensions are nominal unless otherwise noted.

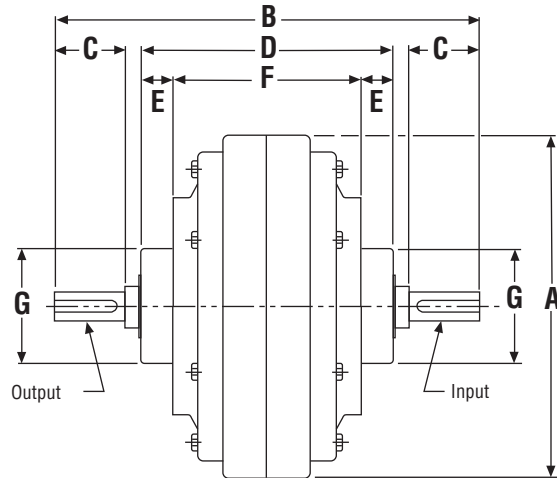

inches/(mm)

Size	Shaft Dimensions			
	H	I	J	K
0.3	0.3937/0.3931 (10.000/9.985)	0.1584/0.158 (4.024/4.012)	0.16 (4)	0.10 (2.5)
0.6	0.4724/0.4717 (12.000/11.982)	0.1584/0.1580 (4.024/4.012)	0.16 (4)	0.10 (2.5)
1.2	0.5906/0.5544 (15.000/14.082)	0.1584/0.1580 (4.024/4.012)	0.20 (5)	0.12 (3)
2.5	0.7874/0.7866 (20.000/19.979)	0.1978/0.1973 (5.024/5.012)	0.20 (5)	0.12 (3)
5	0.9843/0.9834 (25.000/24.979)	0.2768/0.2762 (7.030/7.015)	0.28 (7)	0.16 (4)
10	1.1811/1.1803 (30.000/29.979)	0.2768/0.2762 (7.030/7.015)	0.28 (7)	0.16 (4)
20	1.3780/1.3770 (35.000/34.975)	0.3949/0.3943 (10.030/10.015)	0.31 (8)	0.18 (4.5)
40	1.7717/1.7707 (45.000/44.975)	0.4739/0.4731 (12.036/12.018)	0.31 (8)	0.18 (4.5)

inches/(mm)

Size	A	B	C	D	E	F	G	L			
								Thread Size	Depth	No. of Holes	Bolt Circle
0.3	4.72 (120)	5.79 (147)	0.91 (23)	3.43 (87)	0.43 (11)	2.56 (65)	1.6535/1.6526 (42.000/41.975)	M5	0.39 (10)	6 x 2	2.520 (64)
0.6	5.28 (134)	6.10 (155)	1.02 (26)	3.54 (90)	0.39 (10)	2.76 (70)	1.6535/1.6526 (42.000/41.975)	M5	0.43 (11)	6 x 2	2.520 (64)
1.2	5.98 (152)	7.40 (188)	1.36 (34.5)	4.17 (106)	0.51 (13)	3.15 (80)	1.6535/1.6526 (42.000/41.975)	M6	0.51 (13)	6 x 2	2.520 (64)
2.5	7.17 (182)	8.96 (227.5)	1.69 (43)	4.86 (123.5)	0.59 (15)	3.68 (93.5)	2.1654/2.1642 (55.000/54.970)	M6	0.51 (13)	6 x 2	3.071 (78)
5	8.62 (219)	11.18 (284)	2.24 (57)	5.94 (151)	0.91 (23)	4.13 (105)	2.9134/2.9122 (74.000/73.970)	M6	0.51 (13)	6 x 2	3.937 (100)
10	11.42 (290)	13.70 (348)	2.64 (67)	7.56 (192)	0.98 (25)	5.59 (142)	3.9370/3.9356 (100.000/99.965)	M10	0.71 (18)	6 x 2	5.512 (140)
20	13.19 (335)	15.04 (382)	2.80 (71)	8.50 (216)	0.98 (25)	6.54 (166)	4.3307/4.3293 (110.000/109.965)	M12	0.71 (18)	6 x 2	5.906 (15)
40	15.55 (395)	19.29 (490)	3.62 (92)	10.94 (278)	1.30 (33)	8.35 (212)	5.1181/5.1165 (130.000/129.960)	M12	0.79 (20)	8 x 2	7.874 (200)

\*Air inlet for optional forced air cooling. Consult factory.



MEX (55) 53 63 23 31  
QRO (442) 1 95 72 60

MTY (81) 83 54 10 18  
ventas@industrialmagza.com

## Dimensions Size 80

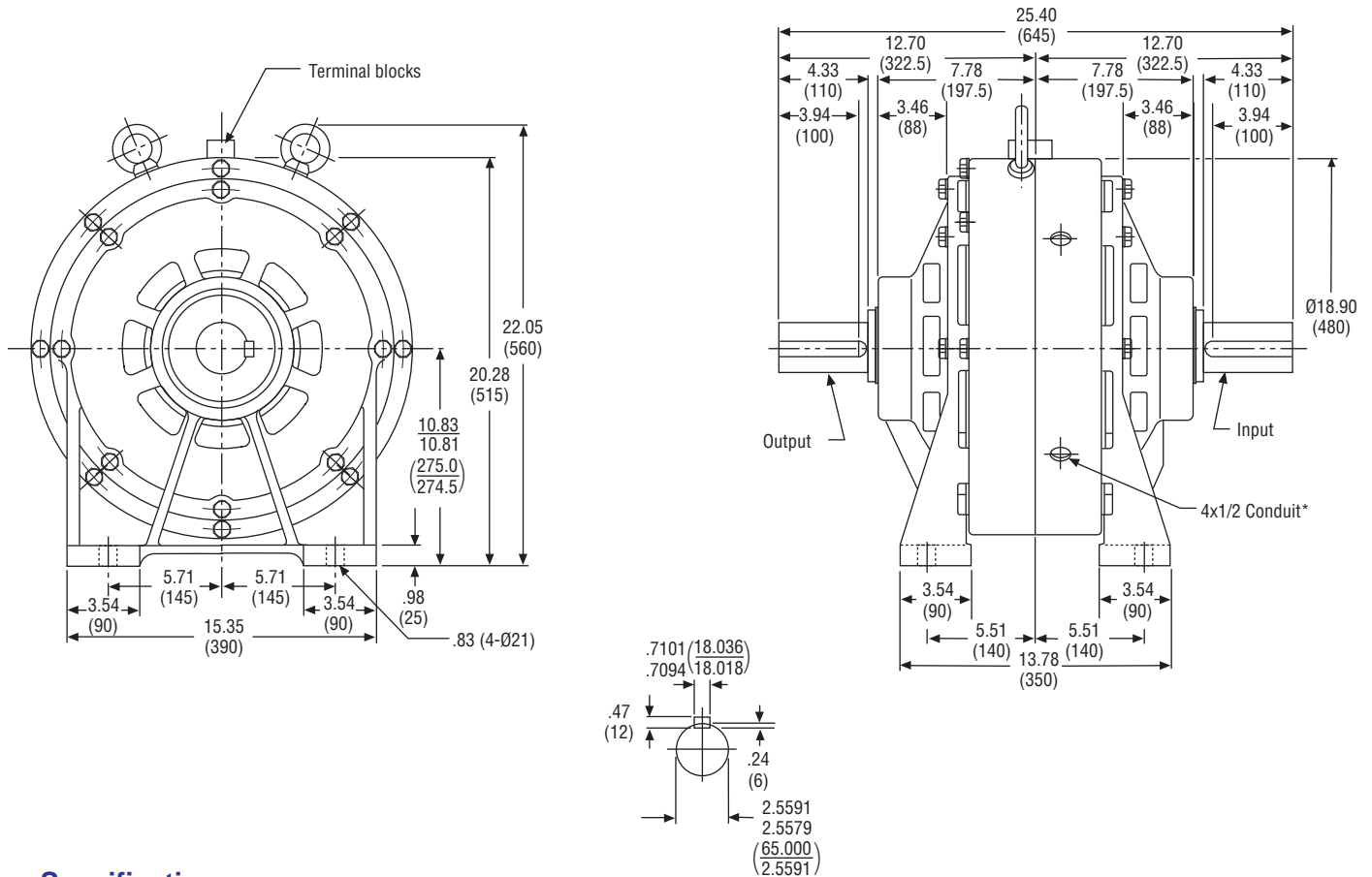

## Specifications

Size	Part Number	Torque (lb. ft.)	Drag Torque (lb. ft.)	Maximum Speed (rpm)	Inertia Input (lb. ft. <sup>2</sup> )	Output (lb. ft. <sup>2</sup> )	Max. Heat Diss. Watts @ Max. RPM	Weight (lbs.)
0.3	5401-270-211	2.1	.065	1,800	.0128	.00477	105	5.5
0.6	5401-270-221	4.3	.13	1,800	.0173	.00570	80	7.9
1.2	5401-270-231	8.6	.26	1,800	.0304	.0104	145	12
2.5	5401-270-241	18	.54	1,800	.0973	.0387	195	22
5	5401-270-251	36	1.1	1,800	.249	.114	290	38
10	5401-270-261	72	2.2	1,800	1.04	.437	460	77
20	5401-270-271	144	4.3	1,800	2.23	1.19	790	128
40	5401-270-281	289	8.7	1,800	5.93	3.08	1,990	220
80	5401-270-291	578	17	1,500	23.5	15.2	3,900	551



# Optional Accessories

## Optional Mounting Bracket (for mounting MPB Brakes and MPC Clutches)

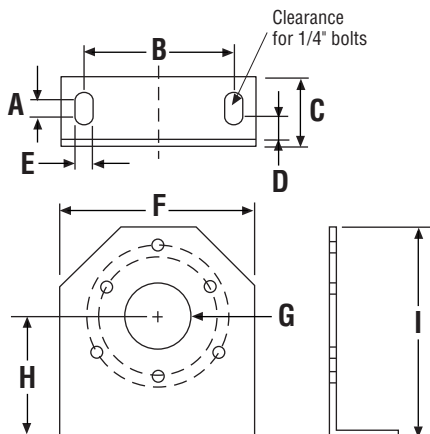

inches/(mm)

Model/Part #	Fits Size	A	B	C	D	E	F	G	H	I
<b>MPB-2B</b> MB2/MC2	2	0.270 (6.9)	1.750 (44.5)	1.155 (29.3)	0.390 (9.9)	0.280 (7.1)	2.500 (63.5)	0.750 (19.1)	1.500 (38.1)	3.000 (76.2)
<b>MPB-15B</b> MB/MC3,MB/MC4	7, 15, 35	0.270 (6.9)	2.500 (63.5)	1.155 (29.3)	0.390 (9.9)	0.280 (7.1)	3.500 (88.9)	1.125 (28.6)	2.000 (50.8)	4.000 (101.6)
<b>MPB-70B</b> MB/MC5	70	0.270 (6.9)	4.875 (123.8)	1.155 (29.3)	0.390 (9.9)	0.280 (7.1)	6.000 (152.4)	1.625 (41.3)	3.500 (88.9)	6.000 (152.4)
<b>MPB-120B</b> MB/MC5.5	120	0.270 (6.9)	4.875 (123.8)	1.155 (29.3)	0.390 (9.9)	0.280 (7.1)	6.000 (152.4)	1.625 (41.3)	3.500 (88.9)	6.250 (158.8)
<b>MPB-240B</b> MB/MC6	240	0.270 (6.9)	4.875 (123.8)	1.155 (29.3)	0.390 (9.9)	0.280 (7.1)	6.500 (165.1)	2.441 (62.0)	4.000 (101.6)	7.500 (190.5)

All dimensions are nominal unless otherwise noted.

**Note:** All MPC Series clutches require 2 mounting brackets.  
MPB Series brakes require 1 mounting bracket.

## Optional Torque Arm (for shaft mounting PRB-H and PRB-HF Brakes)

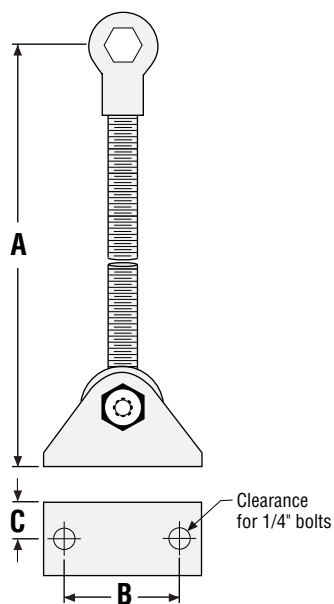

inches/(mm)

Model	Part Number	A inches (mm)	B inches (mm)	C inches (mm)
PRB-1.2H/HF	5401-101-001	9.03 (229.4)	1.50 (38.1)	0.31 (7.9)
PRB-2.5H/HF	5401-101-001	9.03 (229.4)	1.50 (38.1)	0.31 (7.9)
PRB-5H/HF	5401-101-002	11.19 (284.2)	1.50 (38.1)	0.38 (9.5)
PRB-10H/HF	5401-101-002	11.19 (284.2)	1.50 (38.1)	0.38 (9.5)
PRB-20H/HF	5401-101-003	19.31 (490.5)	2.38 (60.3)	0.38 (9.5)

All dimensions are nominal unless otherwise noted.

## Overhung Load

When an overhung load (side load) is applied to the shaft, verify that this load does not exceed the maximum allowable. Operating speed and where the load is applied to the shaft (see Dimension A, Figure 4) must be known. For speed, determine the speed coefficient from the coefficient table. Also, determine the allowable overhung load from the chart based on Dimension A. Multiply the load from the chart times the speed coefficient to determine the allowable load for the application.

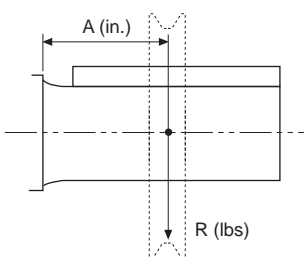

**Figure 4**  
**Overhung Load**

**Note:** Shaft extensions are not recommended.

## Pulley or Sprocket Load

For most applications, the overhung load is caused by pulleys or sprockets. The smaller the pitch diameter (PD) of the pulley or sprocket, the higher the belt or chain tension, and, therefore, the greater the overhung load. To determine the minimum pulley diameter for the application, use the following equation:

$$\text{Minimum PD (in.)} = \frac{24 \text{ TK}}{\text{CR}}$$

T = Torque (lb.ft.) This is the torque actually being transmitted, not necessarily the maximum torque capacity of the brake.

K = Safety factor for the tension in type of drive. Use 1.2 to 1.5 for sprockets, 2 to 4 for belts.

C = Speed coefficient from table.

R = Radial load allowable at 1,000 RPM. (The allowable radial loads for various locations on the shaft are given in the Allowable Load chart.)

**Example:** Determine the minimum sprocket diameter that can be used on a PRS-5S. Dimension A is 1.1 inches, the torque requirement is 20 lb.ft. and the speed is 600 RPM.

$$\text{Minimum PD (in.)} = \frac{24 \times 20 \times 1.5}{1.2 \times 214}$$

$$= 2.8 \text{ inch minimum PD}$$

## Allowable Overhung Load

Type	A (in.)	R (lbs.)	A (in.)	R (lbs.)	A (in.)	R (lbs.)
MPB2/MPC2	.40	5	.50	4	.80	2.5
MPB15/MPC15	.40	25	.50	20	1	10
MPB70/MPC70	.40	37.5	.50	30	1.25	12
MPB120/MPC120	.50	30	1	15	1.5	10
MPB240	.50	50	1	25	1.5	16
POC/POB-0.3	.40	30	.50	28	.90	22
POC/POB-0.6	.40	45	.50	42	1.0	29
POC/POB-1.2	.40	52	.70	43	1.4	31
PRB-1.2S/SF	.40	73	.70	66	1.4	60
POC/POB-2.5	.40	88	.90	67	1.7	48
PTB-2.5BL3 PRB-2.5S/SF	.40	125	.90	104	1.7	82
POC/POB-5 PTB-5BL3	.40	204	1.1	136	2.2	93
PRB-5S/SF	.40	286	1.1	214	2.2	165
POC/POB-10	.40	313	1.3	235	2.6	159
PTB-10BL3 PRB-10S/SF	.40	433	1.3	368	2.6	282
POC/POB-20 PTB-20BL3	.40	379	1.4	265	2.8	198
PRB-20S/SF	.40	521	1.4	412	2.8	348
POC/POB-40	.40	581	1.8	432	3.6	324
POC/POB-80	.40	860	2.2	648	4.3	498

**Note:** This table is based on 1,000 rpm and a bearing life of 6,000 hours. Also, this table assumes that no thrust load is applied.

## Speed Coefficient

Speed (rpm)	Speed Coefficient	Speed (rpm)	Speed Coefficient
50	2.74	1,000	1.00
100	2.18	1,200	0.95
200	1.72	1,400	0.89
400	1.37	1,600	0.86
600	1.20	1,800	0.82
800	1.09	2,000	0.80