



Introduction

Ultrasonic signals are like audible sound waves, except the frequencies are much higher.

Ultrasonic transducers have piezoelectric crystals which resonate to a desired frequency and convert electric energy into acoustic energy and vice versa.

Diagram A shows how sound waves transmitted in the shape of a cone are reflected back to the transducer. At this stage, an output signal is produced to perform some kind of indicating or control function.

A minimum distance from the sensor is required to provide a time delay so that the "echoes" can be interpreted. Variables which can affect the operation of an ultrasonic sensor include: target surface angle, reflective surface roughness, change in temperature or humidity. The targets can have any kind of reflective form and even round objects are an acceptable target.

Advantages of Ultrasonic Sensors

- Discrete distances to moving objects can be detected and measured
- Less affected by target materials and surfaces
- Not affected by color
- Solid state – virtually unlimited maintenance-free life
- Small objects can be detected over longer distances
- Resistance to external disturbances such as vibration, infrared radiation, ambient noise, and EMI radiation

Applications for Ultrasonic Sensors

- Loop control
- Roll diameter, tension control, winding and unwind
- Web break detection
- Level detection/control
- Presence detection

UT30 Series

The Warner Electric UT30 Series Ultrasonic Sensors feature three types of sensors:

- Range measurement with analog output
- Proximity detection with range and hysteresis control
- Long range measurement with analog output
- CE Approved

Range Measurement with Analog Output

This type of sensor is capable of both 4–20mA and/or 0–10V output signals, with an added feature of inverting these signals to 20–4mA and for 10–0V by means of simply wiring the units in the instructed way. Long range sensors come with current (mA) output signals only.

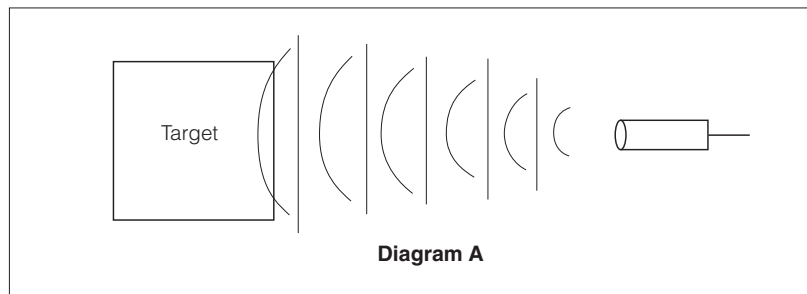

A range measurement sensor works in a very precise, easily controllable way. Precise distance of an object moving to and from the transducer is measured via time intervals between transmitted and reflected bursts of ultrasonic sound. The internal circuit reads this time and then proportionately provides an output in either MAs or volts to that distance.

General Installation Information

Target Angle

This term refers to the "tilt response" limitations of a given sensor. Since ultrasonic sound waves reflect off the target/object, target angles indicate acceptable amounts of tilt for a given sensor. If an application requires a target angle beyond the capabilities of a single sensor, two sensors can be teamed to provide even a broader angle of tilt.

Beam Spread

This term is defined as the area in which a round wand will be sensed if passed through the target area. This is the maximum spreading of the ultrasonic sound as it leaves the transducer.



**Threaded plastic barrel
 M 30 x 1.5**

Analog Output

- 4–20mA and 0–10V
- Wire selectable inverted or non-inverted outputs

Specifications

Sensing Range	4–40" (101..1016mm)	8–80" (203..2032mm)
Ordering Information		
Model Description	UT30UP-DCA4-1016-CSI	UT30UP-DCA4-2032-CSI
Part Number	7600-448-001	7600-448-002
Electrical Data		
Voltage Range (min./max.)	20–30 VDC reverse polarity protected	20–30 VDC reverse polarity protected
Input Current	50mA	50mA
Transducer Frequency	212 KHz	150 KHz
Short Circuit Protected	Yes	Yes
LED – (strength indicator)	Yes – green to red; Page 152	Yes – green to red; Page 152
Response Time	30 mSec	50 mSec
Range Control	Zero and span (2 potentiometers)	Zero and span (2 potentiometers)
Mechanical Data		
Temperature Range (min./max.)	–25°F to +140°F (–31.7°C to +60°C)	–25°F to +140°F (–31.7°C to +60°C)
Degree of Protection	IP65/NEMA12	IP65/NEMA12
Body Material	Valox plastic	Valox plastic
Termination Cable 6 ft. (2m)	PVC 4 x 22 gauge	PVC 4 x 22 gauge
Plug/socket	Versions available to order	Versions available to order
Accessories	1) Brackets	1) Brackets
Humidity	0–95% non-condensing	0–95% non-condensing

Dimensions

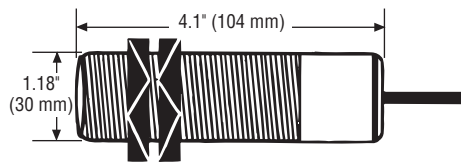

Mounting Bracket

M 30 ST

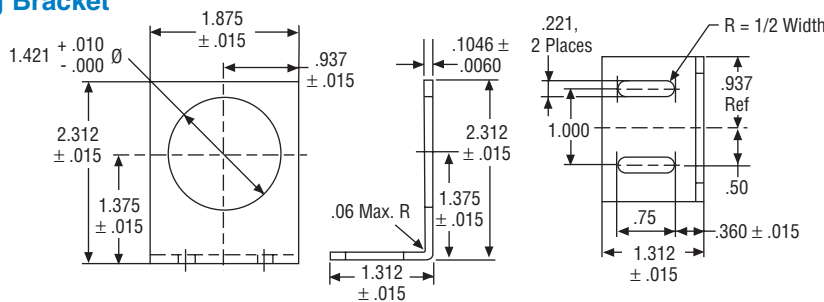

Accessories

Brackets for M 30 x 1.5

Ordering Information

Plastic – BK5-D34PA
 Part Number: 596-0223-041

Metal – M 30 ST
 Part Number: 7430-448-003

***Power Supply** - NG24 110/220 VAC Input
 24 VDC @ 300mA Output
 Part Number: 7500-448-020

Note: Provides output to appropriate analog input control. (Ex. TCS-200-1)

Wiring Data

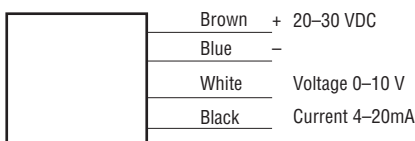

Non-Inverted Output

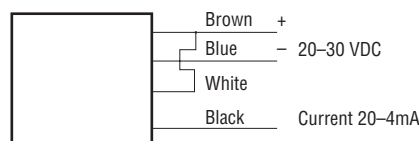

Current Output Inverted

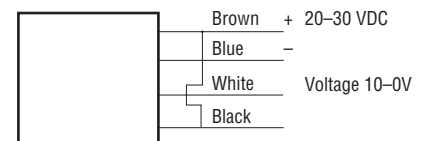

Voltage Output Inverted

***Note:** Some controls do not have 24 VDC outputs for the ultrasonic sensor power. These controls require the use of the NG 24 power supply

Operation and Setup

Minimum Analog Ranging

Minimum analog ranging is when you desire to have the full 4–20 mA or 0–10V output over the minimum 5-inch sensing span. Five inches of minimum sensing span can be adjusted anywhere in the sensing range. For example 10”–15” or 25”–30”. To make this adjustment, place the target at the minimum sensing range and adjust P1 to 4mA. Then move the target to the maximum sensing range and adjust P2 to 20mA. Recheck the ratings and make appropriate adjustments, if necessary. See Diagram A.

Maximum Analog Ranging

Analog sensing in the maximum range means utilizing the entire 36” span (4”–40”) and 72” span (8”–80”). To adjust, set the target at the minimum range, either 4” or 8”, and adjust P1 to 4mA. Move the target to the maximum range and adjust P2 to 20mA. Recheck readings and make appropriate adjustments, if necessary. See Diagram B.

Inverted Analog Outputs

Inverted outputs means that the 4–20mA or 0–10V output signal will decrease proportionally with distance. To adjust, place the target at the minimum sensing distance and adjust P1 to 20mA. Place the target at the maximum sensing distance and adjust P2 to 4mA. Re-check readings and make appropriate adjustments, if necessary. See Diagram C.

LED Operation (Note D)

The LED is green when the unit is powered. It will fade to red as a target is detected with increased intensity as more signal is being reflected from the target. **Note:** Any color other than green equals a workable signal level.

Adjustment Pots Zero and Span Control

