

Magnetic Brakes and Clutches

M Series – Permanent Magnet

Fast, precise torque adjustment!

Precision Tork™ clutches and brakes

Precision Tork units provide constant torque independent of slip speed. They offer excellent overload and jam protection for all drive train components and also provide soft starts with zero slip when a preset torque is reached. Precision Tork permanent magnet clutches and brakes do not require maintenance and provide extremely long life. Since they operate from permanent magnets, no outside control or power source is required.

Features and Benefits

Fast, precise torque adjustment

- Torque is set with a large knurled adjustment ring.
- Infinite adjustability between minimum and maximum settings. This allows units to be fine tuned to your unique requirement.
- Easy to read graduations.

Torque is constant with respect to speed

- Torque is extremely consistent and smooth at low, as well as high, speeds.
- By using the Precision Tork unit, you can solve almost any torque control problem.

No external control or power source

- Simple to install
- Nothing to monitor
- Unaffected by power interruption or power fluctuation
- Safe to use

Dependable performance

- Smallest possible transition from static to dynamic torque. Virtually eliminates the “stick-slip” phenomenon associated with friction devices.
- Long life. The only wearing parts are the ball bearings.
- Extremely accurate. Precision Tork units out-perform all other devices at low RPM.

Versatile mounting: Easy to retrofit

- Clutches are available with hollow bores for mounting on motor shafts or jack shafts.
- Bolt circles allow for fixed mounting, adding a pulley, or stub shaft adapter.
- Brakes are available with solid shaft outputs.

Distributor item

- Off the shelf availability.
- Interchangeable with competitors' products.

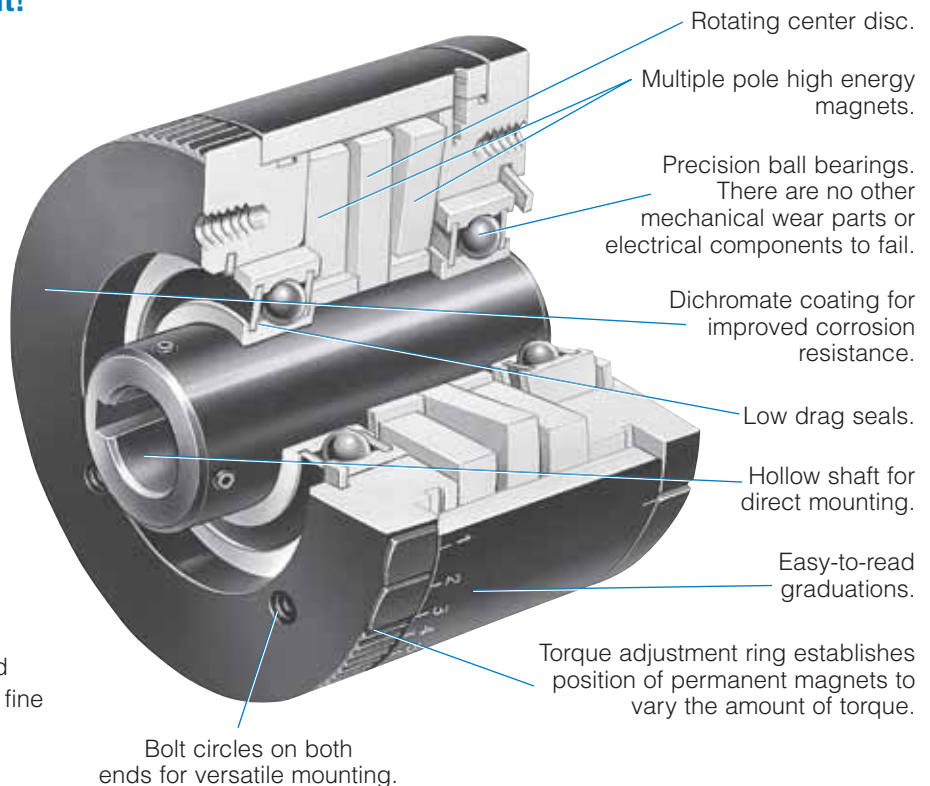

Special Applications

Specials are our business. . .

- Special shaft bores and keyways
- Shaft extensions
- System retrofits
- Metric bores and keyways
- Stainless steel construction
- Fixed torque units



Magnetic Brakes and Clutches

M Series – Permanent Magnet

Unwind tension control

Brake mounted on shaft of unwind spool or bobbin.



Film unwind
Tension provided by hysteresis units.

Information required:

Full roll diameter (in.) = 6 in.
Core diameter (in.) = 4 in.
Average tension (lbs.) = 4 lbs.
Velocity (feet per min.) = 100 fpm

How to size:

$$\begin{aligned} \text{Average radius (in.)} &= \frac{\text{Full roll dia. (in.)} + \text{Core dia. (in.)}}{4} \\ &= \frac{6 + 4}{4} = 2.5 \text{ in.} \end{aligned}$$

Torque (lb.in.) =

$$\begin{aligned} \text{Avg. tension (lbs.)} \times \text{Avg. radius (in.)} \\ = 4 \times 2.5 = 10 \text{ lb.in.} \end{aligned}$$

Check tension range:

$$\begin{aligned} \text{Max. tension} &= \text{Torque (lb.in.)} \times \\ &\frac{2}{\text{Core dia. (in.)}} = 10 \times \frac{2}{4} = 5 \text{ lbs.} \end{aligned}$$

Min. tension = Torque (lb.in.) x

$$\frac{2}{\text{Full roll dia. (in.)}} = 10 \times \frac{2}{6} = 3.3 \text{ lbs.}$$

Slip watts =

$$\begin{aligned} \frac{\text{Max. tension (lbs.)} \times \text{velocity (fpm)}}{44.2} \\ = 11.3 \text{ watts} \end{aligned}$$

Select Model MC4

Cycling

Bottle capping

Constant torque provided by a hysteresis clutch.

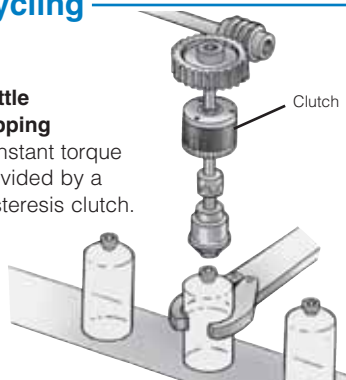

Information required:

Slip RPM = 500 RPM
Torque = 8 lb.in.
% slip time of total cycle time = 25%

How to size:

$$\begin{aligned} \text{*Watts} &= .0118 \times \text{torque (lb.in.)} \times \text{slip} \\ \text{RPM} \times \% \text{ slip time} &= .0118 \times 8 \times \\ 500 \times .25 &= 11.8 \text{ watts} \end{aligned}$$

Select an MC4 from the specification chart.

*Note: Consult factory if peak slip watts are extremely high or if duration of slip period is in excess of 1 minute.

Nip roll or pulley tension control

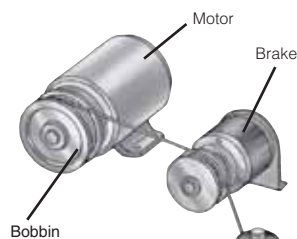

Coil winding

Constant tension provided by hysteresis unit.

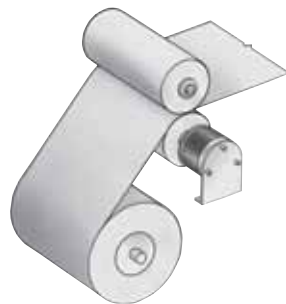

Film tensioning

Constant tensioning supplied by hysteresis unit.

Information required:

Pulley or nip roll diameter = 4 in. Tension = 6 lbs. Velocity = 100 fpm

How to size:

$$\text{Torque (lb.in.)} = \text{Tension (lbs.)} \times \frac{\text{Dia. (in.)}}{2} = 6 \times \frac{4}{2} = 12 \text{ lb.in.}$$

$$\text{Slip watts} = \frac{\text{Tension (lbs.)} \times \text{velocity (fpm)}}{44.2} = \frac{6 \times 100}{44.2} = 13.5 \text{ watts}$$

Select Model MC5

Overload protection/Torque limiting/Soft start

Motor horsepower method

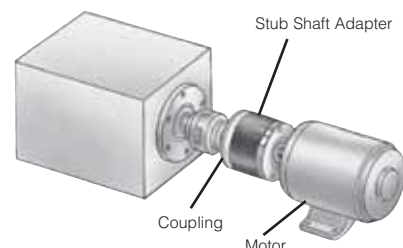

Torque limiting

Hysteresis clutch provides overload protection.

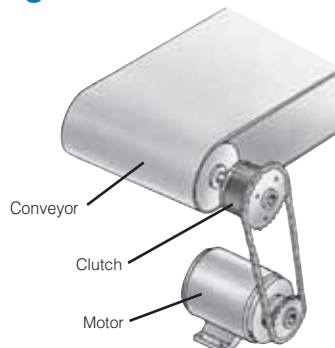

Material handling

Hysteresis clutch provides overload protection and soft start.

Information required:

Motor HP = 1/2 HP
Motor RPM = 1750 RPM

How to size:

$$\begin{aligned} \text{Torque (lb.in.)} &= \frac{\text{HP} \times 63000}{\text{RPM}} = \\ \frac{1/2 \times 63000}{1750} &= 18 \text{ lb.in.} \end{aligned}$$

Select an MC5 from the specification chart.

Magnetic Brakes and Clutches

M Series – Permanent Magnet

Specifications

Clutches



Model Size	Torque	Heat Dissipation (watts)	Inertia (oz.in./sec. ²)	Bending Moment (lb.in.)	Max. RPM	Weight (lbs.)	Bore Range/Shaft Dia. (in.)
MC1.5	1–10 oz.in.	10	0.7×10^{-3}	5	3600	11 oz.	1/4
MC2	1–22 oz.in.	10	0.7×10^{-3}	5	3600	11 oz.	1/4
MC3	0.3–6.0 lb.in.	18	6.5×10^{-3}	10	1800	2	3/8
MC4	0.5–11 lb.in.	22	13.3×10^{-3}	10	1800	2.5	3/8, 1/2, 5/8
MC5	1–30 lb.in.	72	77×10^{-3}	25	1800	9	3/8, 1/2, 5/8, 3/4, 7/8, 1
MC5.5	1–50 lb.in.	110	120×10^{-3}	25	1800	11	5/8, 3/4, 7/8, 1
MC6	2–70 lb.in.	150	196×10^{-3}	25	1800	12	5/8, 3/4, 7/8, 1
MC9	15–300 lb.in.	345	600×10^{-3}	50	1200	45	5/8, 3/4, 7/8, 1, 1-1/8, 1-1/4

Brakes



MB1	0-1.1 oz.in.	3	3.5×10^{-5}	1	3600	2 oz.	3/16
MB1.5	1-10 oz.in.	10	0.9×10^{-3}	5	3600	11 oz.	1/4
MB2	1–22 oz.in.	10	0.9×10^{-3}	5	3600	11 oz.	1/4
MB3	0.3–6.0 lb.in.	18	6.9×10^{-3}	10	1800	2	3/8
MB4	0.5–11 lb.in.	22	13.7×10^{-3}	10	1800	2.5	5/8
MB5	1–30 lb.in.	72	82×10^{-3}	25	1800	9	1
MB5.5	1–50 lb.in.	110	125×10^{-3}	25	1800	11	1
MB6	2–70 lb.in.	150	201×10^{-3}	25	1800	12	1
MB9	15–300 lb.in.	345	600×10^{-3}	50	1200	45	1

Typical Mounting Arrangements

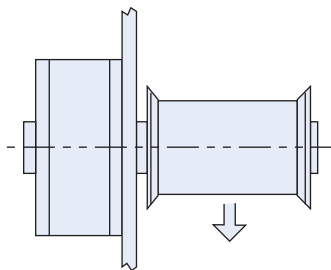

Brake:

Typical setup for tensioning wire, film and fibers.

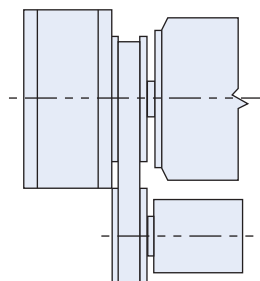

Clutch:

Typical setup for material handling, soft starts and torque limiting.

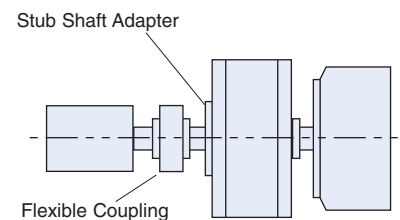

Clutch Coupling:

Typical setup for torque limiting protection used for labeling, capping and printing applications.

Magnetic Brakes and Clutches

M Series – Permanent Magnet

Heat Dissipation Charts

Clutches/Brakes

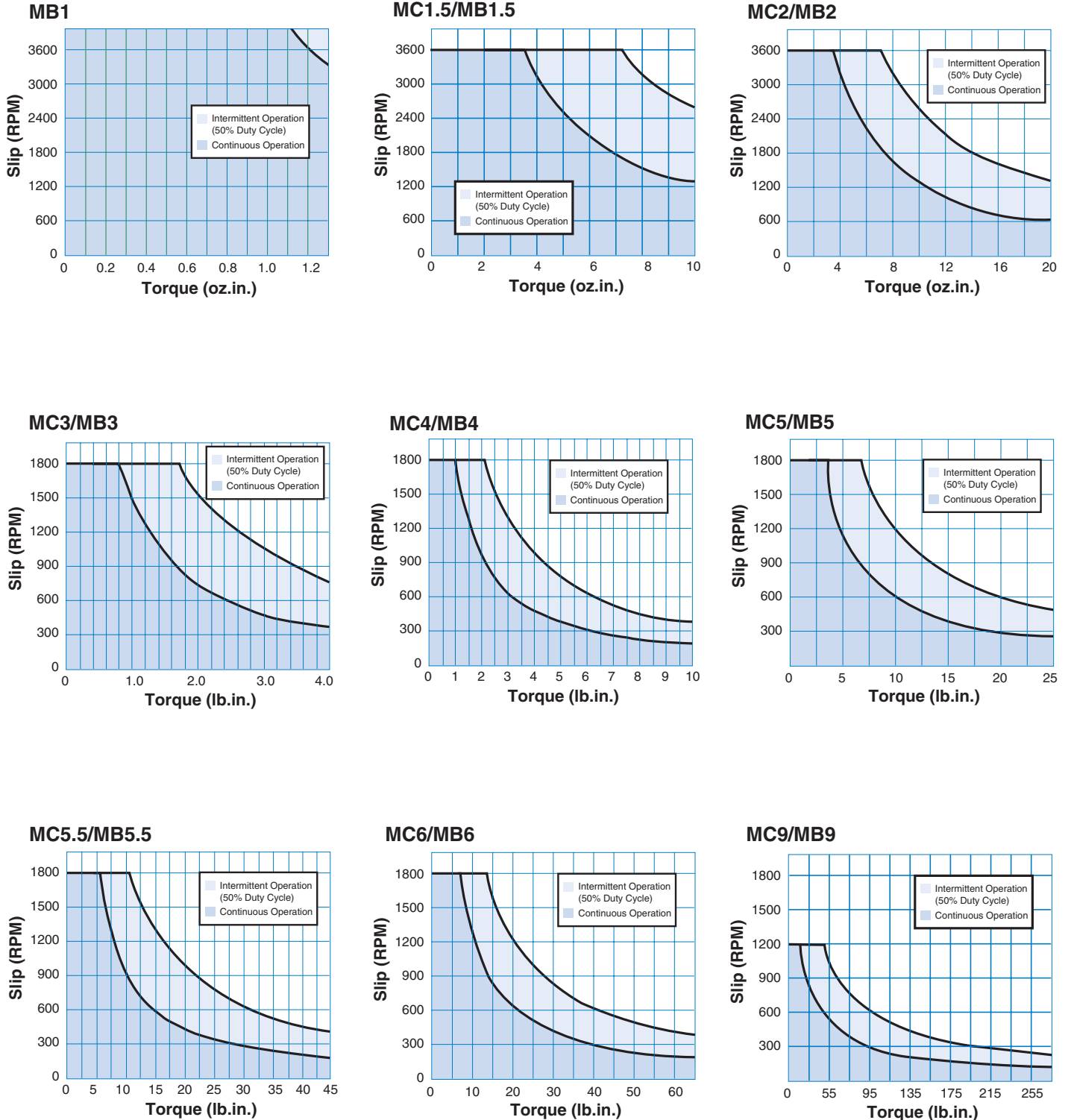

Note: Torque output at a given setting will vary up to 3% from unit to unit. Matched units are available upon request.



MEX (55) 53 63 23 31 MTY (81) 83 54 10 18
 QRO (442) 1 95 72 60 ventas@industrialmagza.com

Magnetic Brakes and Clutches

M Series – Permanent Magnet

Torque Setting Charts

Clutches/Brakes

MB1

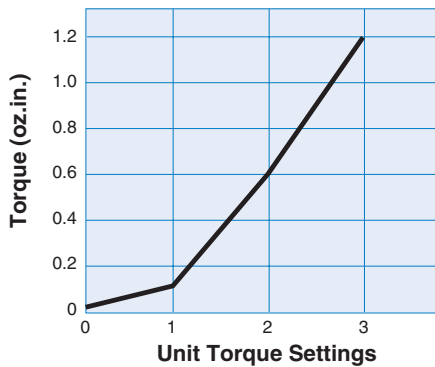

MC2/MB2

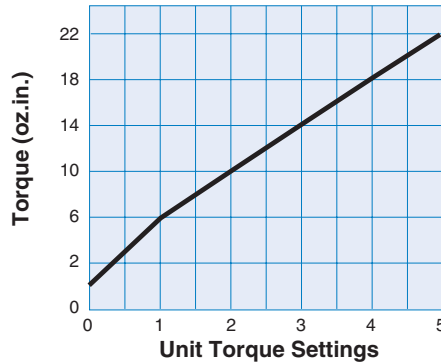

MC3/MB3

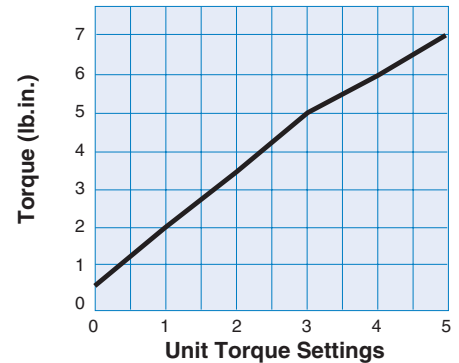

MC4/MB4

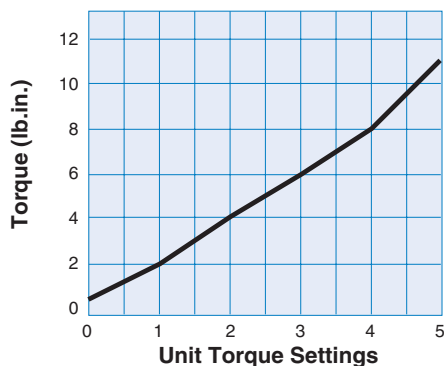

MC5/MB5

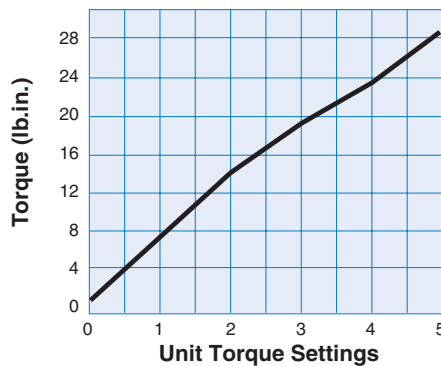

MC5.5/MB5.5

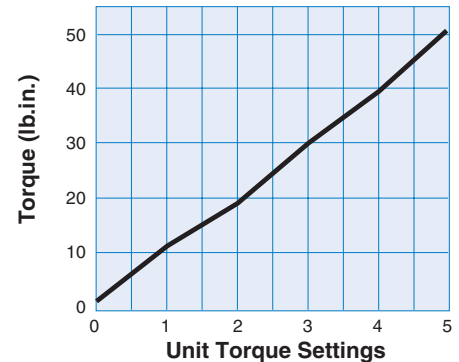

MC6/MB6

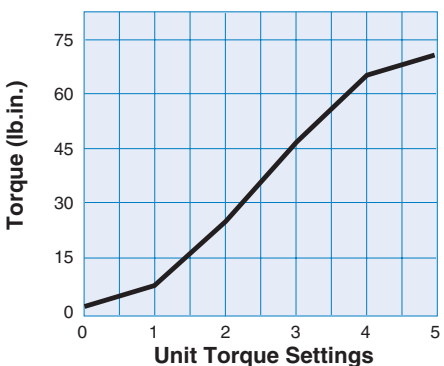

MC9/MB9

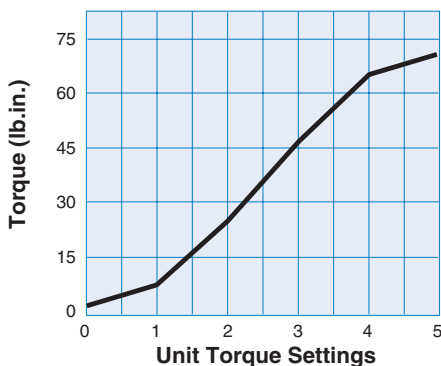

Note: Torque output at a given setting will vary up to 3% from unit to unit. Matched units are available upon request.



MEX (55) 53 63 23 31 MTY (81) 83 54 10 18
 QRO (442) 1 95 72 60 ventas@industrialmagza.com

Magnetic Brakes and Clutches

M Series – Permanent Magnet

MC – Magnetic Clutches

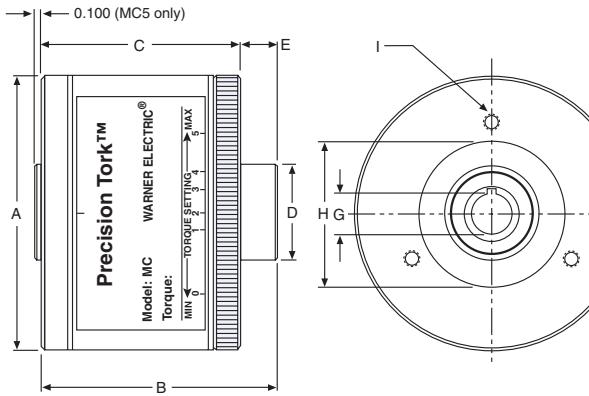

Drawing A

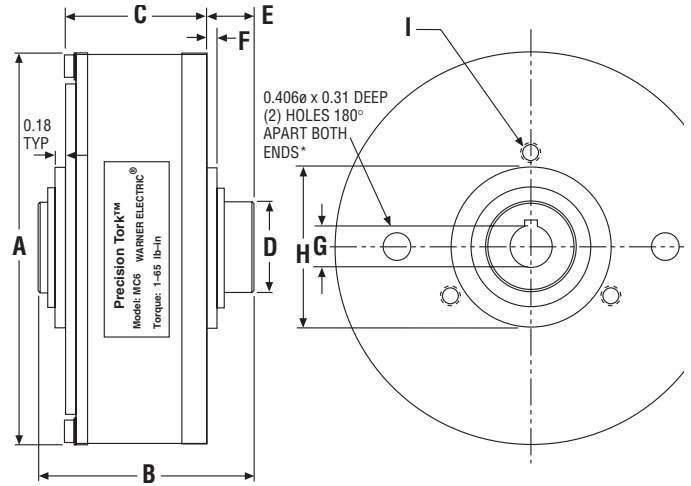

Drawing B

Model	Drawing	A	B	C	D	E	F
MC1.5*	A	1.85	1.61	1.35	0.375	0.26	–
MC2*	A	1.85	1.61	1.35	0.375	0.26	–
MC3*	A	2.75	2.24	2.00	0.590	0.24	–
MC4*	A	3.23	2.26	2.00	0.984	0.26	–
MC5*	A	4.65	3.18	2.65	1.378	0.42	–
MC5.5*	A	5.29	3.25	2.65	1.378	0.60	–
MC6**	B	6.10	3.18	2.04	1.378	0.73	0.18
MC9**	B	9.4	4.17	3.49	1.77	0.55	0.13

* Set screw adjustment

** Spanner wrench required for adjustment. Spanner wrench P/N YZ00-0007

Bore & Keyseat Sizes

Model	Keyseat	Lockdown Method	G (Bore)	H (Pilot-Both Ends)	I (Both Ends)
MC1.5	None	3/32 Roll Pin	1/4	0.875/0.874 x 0.08 dp	3) 6-32 x 5/16 dp 1.25 B.C.
MC2	None	3/32 Roll Pin	1/4	0.875/0.874 x 0.08 dp	3) 6-32 x 5/16 dp 1.25 B.C.
MC3	None	2) Set Screws	3/8	1.383/1.381 x .120 dp	3) 10-32 x 7/16 dp 1.875 B.C.
MC4	None	3/32 Roll Pin	3/8	1.850x1.849 x 0.08 dp	3) 10-32 x 7/16 dp 2.375 B.C.
	1/8 Key	2) Set Screws	1/2		
	3/16 Key	2) Set Screws	5/8		
MC5	None	2) Set Screws	3/8	2.441/2.440 x .100 dp	3) 10-32 x 1/2 dp 3.00 B.C.
	1/8 Key	2) Set Screws	1/2		
	3/16 Key	2) Set Screws	5/8		
	3/16 Key	2) Set Screws	3/4		
	3/16 Key	2) Set Screws	7/8		
	1/4 Shallow	2) Set Screws	1		
MC5.5	3/16 Key	2) Set Screws	5/8	2.441/2.440 x .100 dp	3) 10-32 x 1/2 dp 3.00 B.C.
	3/16 Key	2) Set Screws	3/4		
	3/16 Key	2) Set Screws	7/8		
	1/4 Shallow	2) Set Screws	1		
MC6	3/16 Key	2) Set Screws	5/8	2.441/2.440	3) 1/4-20 x 5/16 dp 2.875 B.C.
	3/16 Key	2) Set Screws	3/4		
	3/16 Key	2) Set Screws	7/8		
	1/4 Shallow	2) Set Screws	1		
MC9	3/16 Key	2) Set Screws	5/8	3.250/3.248	4) 5/16-18 x 1/2 dp 5.875 B.C.
	3/16 Key	2) Set Screws	3/4		
	3/16 Key	2) Set Screws	7/8		
	1/4 Key	2) Set Screws	1		
	1/4 Key	2) Set Screws	1-1/8		
	1/4 Key	2) Set Screws	1-1/4		

Magnetic Brakes and Clutches

M Series – Permanent Magnet

MB – Magnetic Brakes

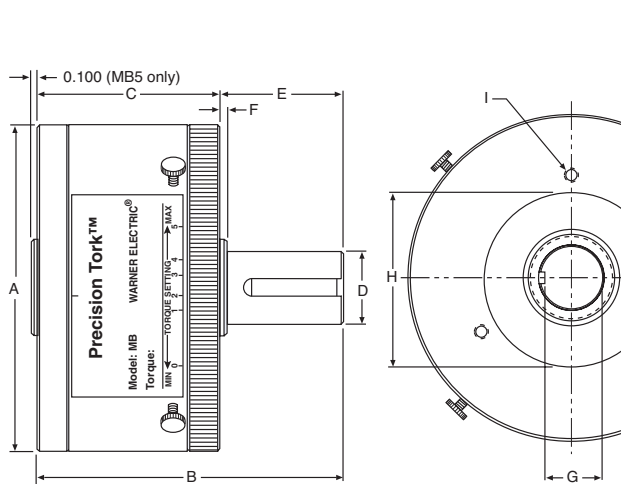

Drawing C

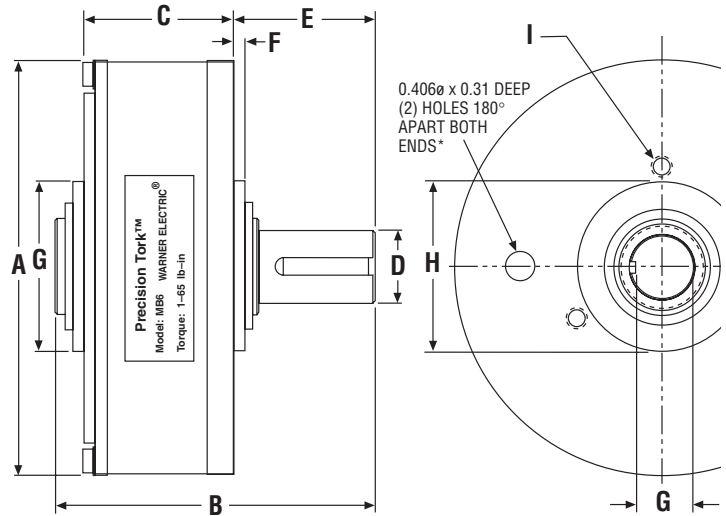

Drawing D

Optional Mounting brackets, see page 127

Model	Drawing	A	B	C	D (Shaft)	E	F	G	H (Pilot-Both Ends)	I (Both Ends)
MB1*	C	1.00	1.39	0.85	3/16	0.58	–	0.170 Flat	0.301/0.302 x 0.100 dp	3) 4-40 x 1/4 dp 0.610 B.C.
MB1.5*	C	1.85	2.35	1.35	1/4	1.00	–	0.230 Flat	0.875/0.874 x 0.08 dp	3) 6-32 x 5/16 dp 1.250 B.C.
MB2*	C	1.85	2.35	1.35	1/4	1.00	–	0.230 Flat	0.875/0.874 x 0.08 dp	3) 6-32 x 5/16 dp 1.250 B.C.
MB3*	C	2.75	3.02	2.00	3/8	1.03	0.03	0.350 Flat	1.383/1.381 x 0.12 dp	3) 10-32 x 7/16 dp 1.875 B.C.
MB4*	C	3.23	2.97	2.00	5/8	0.97	0.09	0.518/0.503	1.850/1.849 x 0.08dp	3) 10-32 x 7/16 dp 2.375 B.C.
MB5*	C	4.65	4.40	2.65	1	1.75	0.11	0.859/0.844	2.441/2.440 x 0.100 dp	3) 10-32 x 1/2 dp 3.000 B.C.
MB5.5*	C	5.29	4.53	2.65	1	1.88	0.25	0.859/0.844	2.441/2.440 x 0.100 dp	3) 10-32 x 1/2 dp 3.000 B.C.
MB6**	D	6.10	4.50	2.04	1	2.22	0.18	0.859/0.844	2.441/2.440	3) 1/4-20 x 5/16 dp 2.875 B.C.
MB9**	D	9.40	5.41	3.49	1	1.80	0.13	0.859/0.844	3.250/3.248	3) 5/16-18 x 1/2 dp 5.875 B.C.

* Thumb screw adjustment

** Spanner wrench required for adjustment. Spanner wrench P/N YZ00-0007

Stub Shaft Adapter



- Utilized when "clutch coupling" configuration is desired.
- Comes complete with attachment hardware and drive key.
- Stub shaft adapters should be used in conjunction with a flexible coupling.

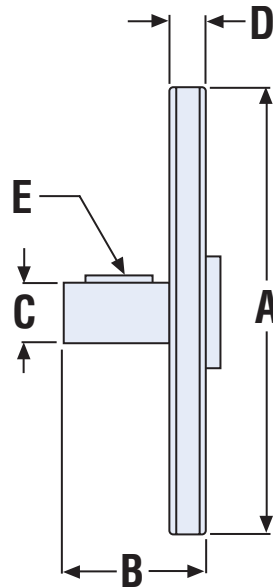

Model Size	Clutch Model	A	B	C	D	E
A2-14	MC2	1.60	0.78	1/4	0.15	Flat
A3-38	MC3	2.36	1.19	3/8	0.19	Flat
A4-38	MC4	2.86	1.19	3/8	0.19	Flat
A4-58	MC4	2.86	1.19	5/8	0.19	3/16" Key
A5-1	MC5, MC5.5	3.45	1.72	1	0.27	1/4" Key
A5-12	MC5, MC5.5	3.45	1.47	1/2	0.27	1/8" Key
A6-34	MC6	3.40	1.70	3/4	0.35	3/16" Key