

Clutch Coupling

SFC-825 Flange Mounted

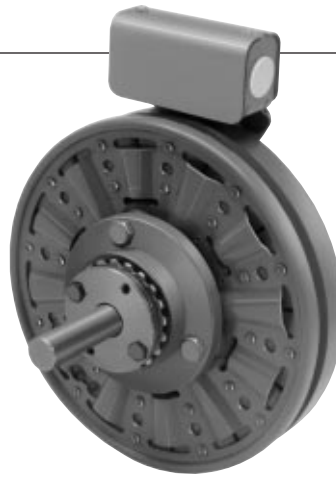

See page 252 for details on Bushings.

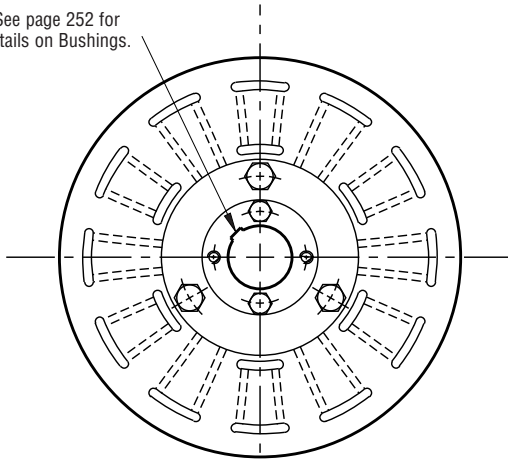

ARMATURE VIEW

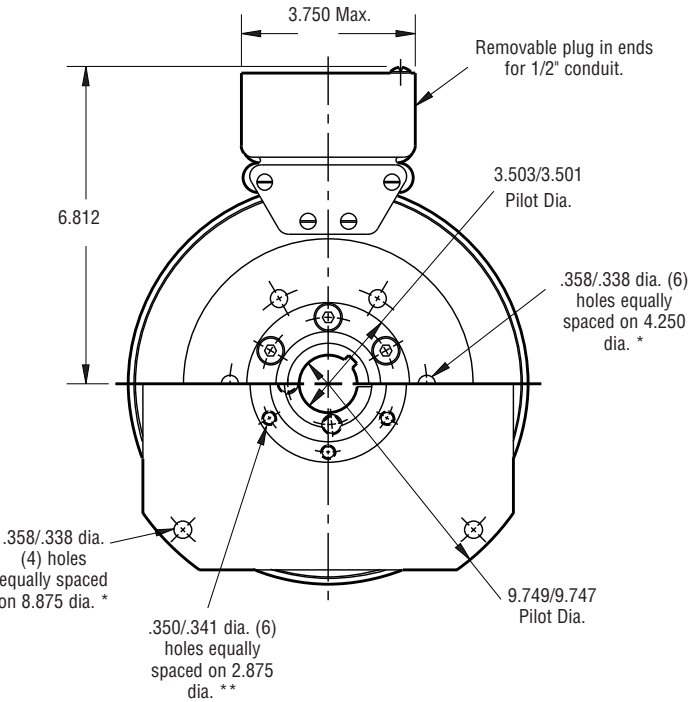

FIELD VIEW

(Inside & Outside Mounted)

Customer Shall Maintain:

1. Concentricity of field mounting pilot diameter with rotor mounting shaft within .006 T.I.R.
2. Squareness of field mounting face with rotor shaft within .006 T.I.R. measured at field mounting bolt circle.
3. Rotor mounting shaft concentric with armature mounting shaft within .006 T.I.R.
4. Angular alignment of shafts within 1/2 degree.

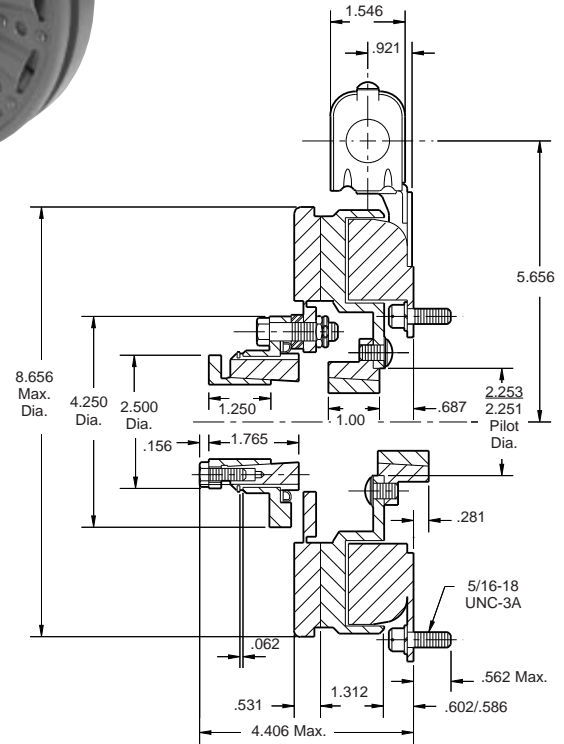

* Mounting holes are within .010 of true position relative to pilot diameter.

** Mounting holes are within .008 of true position relative to pilot diameter.

Armature Shaft	.500 – 1.500
Rotor Shaft	.500 – 1.250
Static Torque	125 lb. ft.
Maximum Speed	4,000 rpm
Standard Voltage	D.C. 6, 24, 90

All dimensions are nominal unless otherwise noted.

Information on inertia and weights begins on page 239. Coil data is on pages 250 and 251.

Note: The two mating shafts on which the clutch is mounted must be mounted rigidly to prevent flexing during engagement. Any flexing will cause vibration and rapid clutchwear. The drive motor should not be mounted on the reducer "scoop" mount or other flexible mounts.

Drawing I-25564

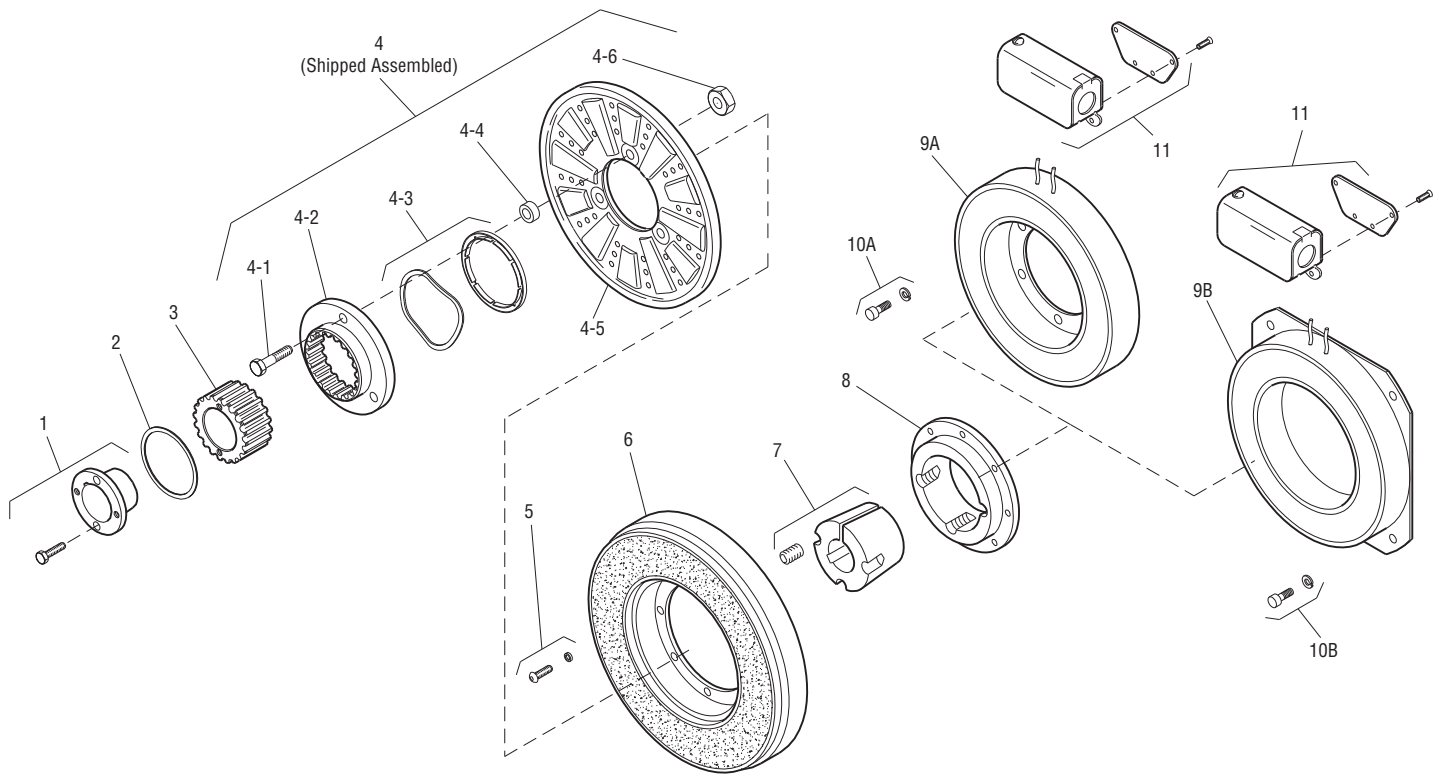

Item	Description	Part Number	Qty.
1	Bushing*		1
	1/2" to 1-1/2" Bore	180-0002 to 180-0018	
2	Retainer Ring	748-0006	1
3	Splined Hub	540-0057	1
4	Armature & Splined Adapter	5201-111-001	1
4-1	Capscrew	797-0341	3
4-2	Splined Adapter	104-0008	1
4-3	Autogap Accessory	5321-101-006	1
4-4	Spacer	748-0333	3
4-5	Armature	5321-111-022	1
4-6	Locknut	661-0004	3
5	Mounting Accessory	5201-101-007	1
6	Rotor		1
	Standard Friction Material	5201-751-003	
	†Optional LK Facing	5201-751-007	
7	Bushing*		1
	1/2" to 1-1/4" Bore	180-0101 to 180-0013	
8	Rotor Hub	540-0013	1
9A	Field - Inside Mounted		1
	6 Volt	5201-451-006	
	24 Volt	5201-451-008	
	90 Volt	5201-451-010	

Item	Description	Part Number	Qty.
9B	Field - Outside Mounted		1
	6 Volt	5201-451-014	
	24 Volt	5201-451-016	
	90 Volt	5201-451-018	
10A	Mounting Accessory - I.M.	5321-101-001	1
10B	Mounting Accessory - O.M.	5321-101-002	1
11	Conduit Box	5200-101-012	1

How to Order:

1. Specify Bore Size for Item 1.
2. Specify Bore Size for Item 7.
3. Specify Voltage for Item 9A or 9B.
4. Specify Inside Mounted for Items 9A and 10A or Outside Mounted for Items 9B and 10B.
5. See Controls Section.

Example:

SFC-825 Clutch Coupling per I-25564 - 90 Volt, Inside Mounted, 1" Bore (Item 1), 1" Bore (Item 7)

These units, when used in conjunction with the correct Warner Electric conduit box, meet standards of UL508 and are listed under guide card #NMTR, file #59164. These units are CSA certified under file #LR11543.

*See page 252 for specific part numbers.

Refer to Service Manual P-207.

†Optional LK facing available. For more information, see page 232.