

Clutch Coupling

SFC-400 Flange Mounted

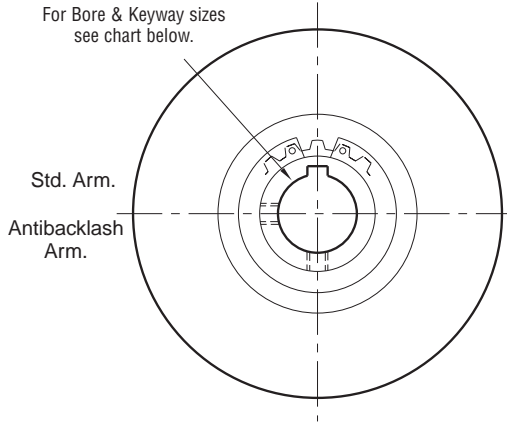

ARMATURE VIEW

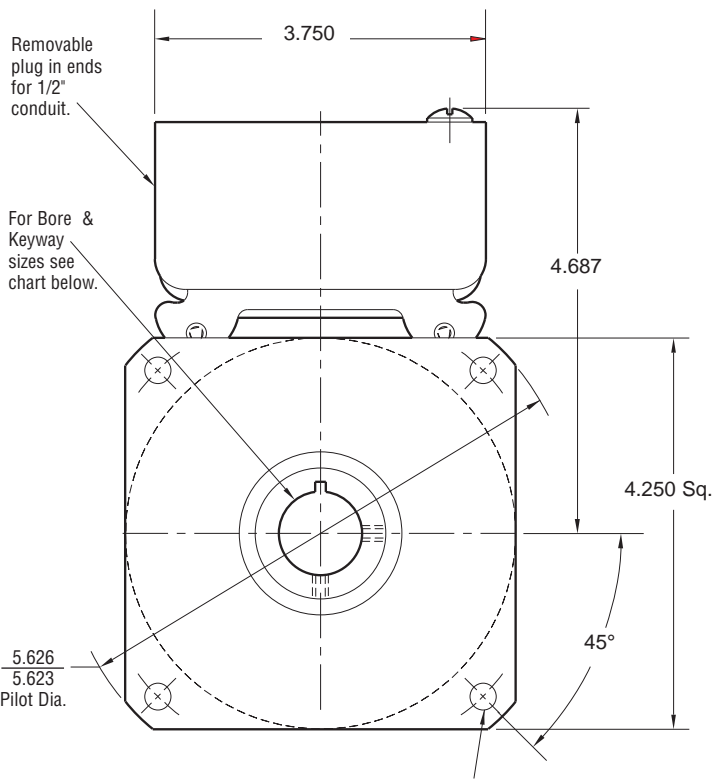

.296/.280 dia. (4) holes equally spaced on 5.000 dia.*

FIELD VIEW

*Mounting holes are within .010 of true position relative to pilot diameter.

Customer Shall Maintain:

1. Squareness of field mounting face with rotor shaft within .003 T.I.R. measured at pilot diameter.
2. Concentricity of field mounting pilot diameter with rotor mounting shaft within .003 T.I.R.
3. Rotor and armature shafts in line within .003 T.I.R.

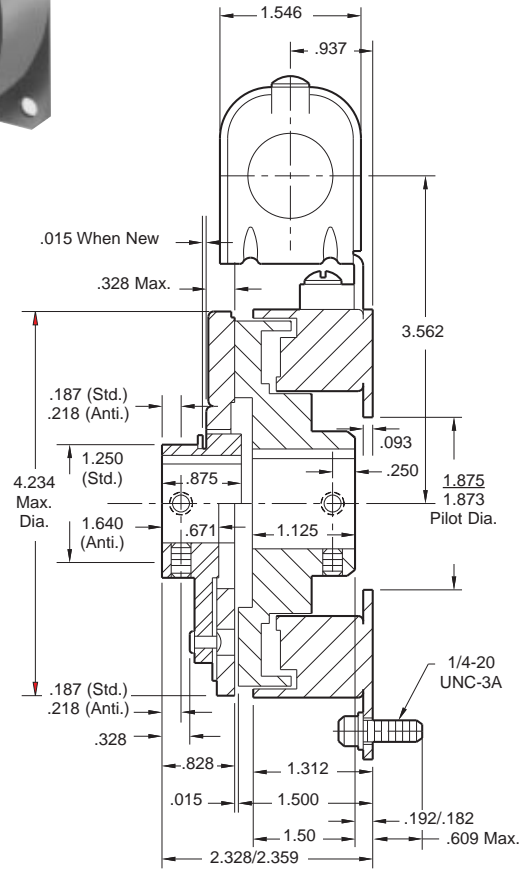

Bore and Keyway Dimensions

Armature Bore Dia.	Keyway	Rotor Bore Dia.	Keyway
.501/.500	.125 x .062	.501/.500	.125 x .062
*.563/.562			
.626/.625		.626/.625	
*.688/.687	.187 x .093	.751/.750	.187 x .093
.751/.750		.876/.875	
.876/.875		1.001/1.000	

*Available on special order only

Static Torque	270 lb. in.
Maximum Speed	4,500 rpm
Standard Voltage	D.C. 6, 24, 90

All dimensions are nominal unless otherwise noted.

Information on inertia and weights begins on page 239. Coil data is on pages 250 and 251.

Drawing I-25697

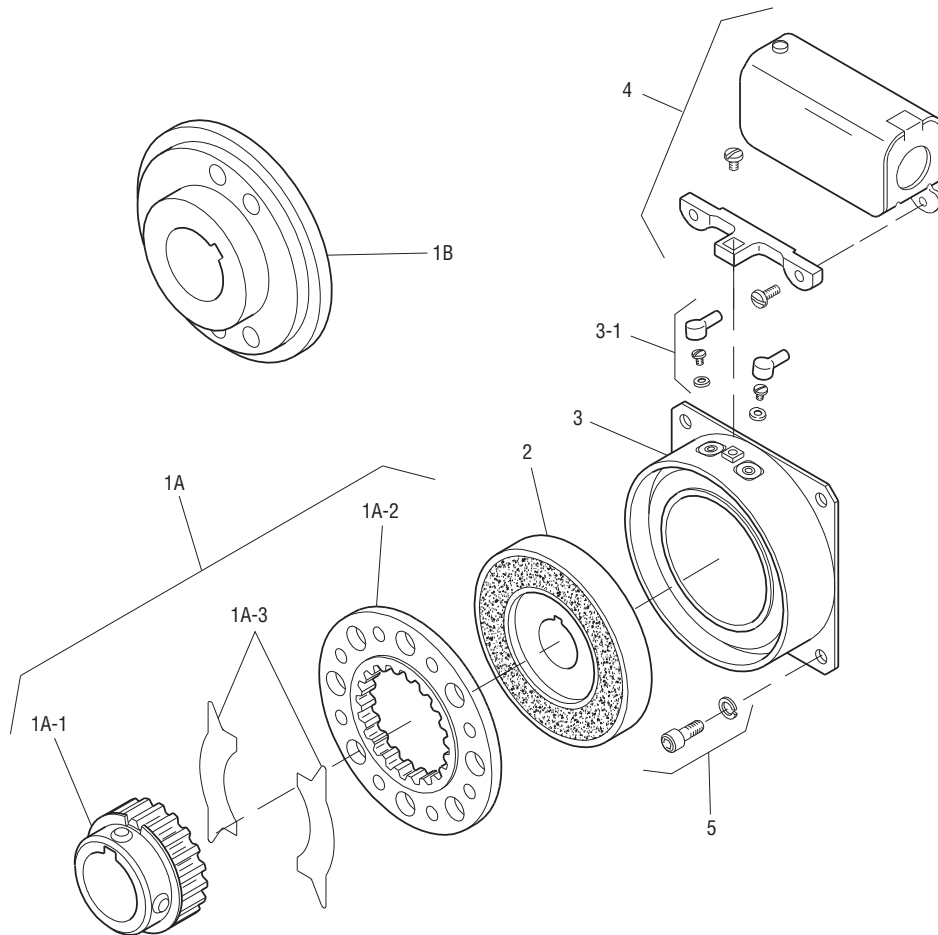

Item	Description	Part Number	Qty.
1A	Armature and Hub		
1A-1	Armature Hub		1
	1/2" Bore	5104-541-002	
	5/8" Bore	5104-541-004	
	3/4" Bore	5104-541-006	
	7/8" Bore	5104-541-007	
1A-2	Armature	5125-111-001	1
1A-3	Release Spring	5104-101-003	1
1B	Antibacklash Armature		1
	1/2" Bore	5367-111-003	
	5/8" Bore	5367-111-005	
	3/4" Bore	5367-111-007	
	7/8" Bore	5367-111-008	
2	Rotor		1
	1/2" Bore	5104-751-033	
	5/8" Bore	5104-751-034	
	3/4" Bore	5104-751-035	
	7/8" Bore	5104-751-036	
	1" Bore	5104-751-037	
3	Field		1
	6 Volt	5104-451-032	
	24 Volt	5104-451-033	
	90 Volt	5104-451-034	

Item	Description	Part Number	Qty.
3-1	Terminal Accessory	5103-101-002	1
4	Conduit Box	5200-101-010	1
5	Mounting Accessory	5104-101-002	1

How to Order:

1. Specify Type of Armature Desired.
2. Specify Bore Size for Item 1A-1 or 1B and Item 2.
3. Specify Voltage for Item 3.
4. See Controls Section.

Example:

SFC-400 Clutch Coupling per I-25697 - 90 Volt
 3/4" Armature Hub Bore
 3/4" Rotor Bore

These units, when used in conjunction with the correct Warner Electric conduit box, meet standards set forth in UL508 and are listed under guide card #NMTR2, file #59164.

These units are CSA certified under file #LR11543.

Refer to Service Manual P-200.