

Clutch Coupling

SFC-120 Flange Mounted

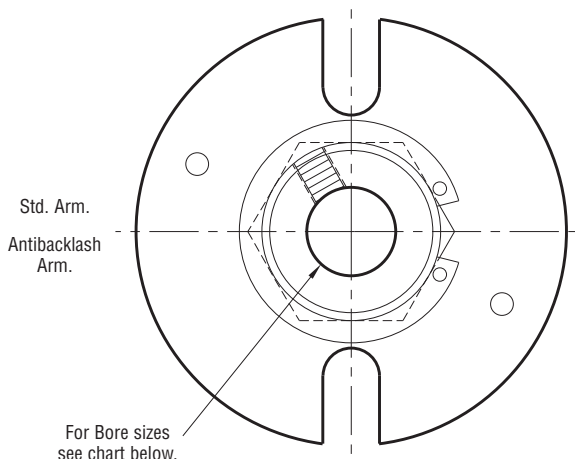

ARMATURE VIEW

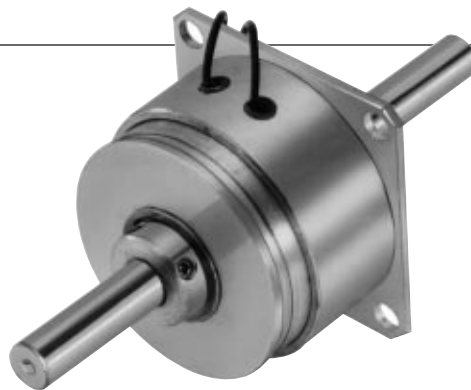
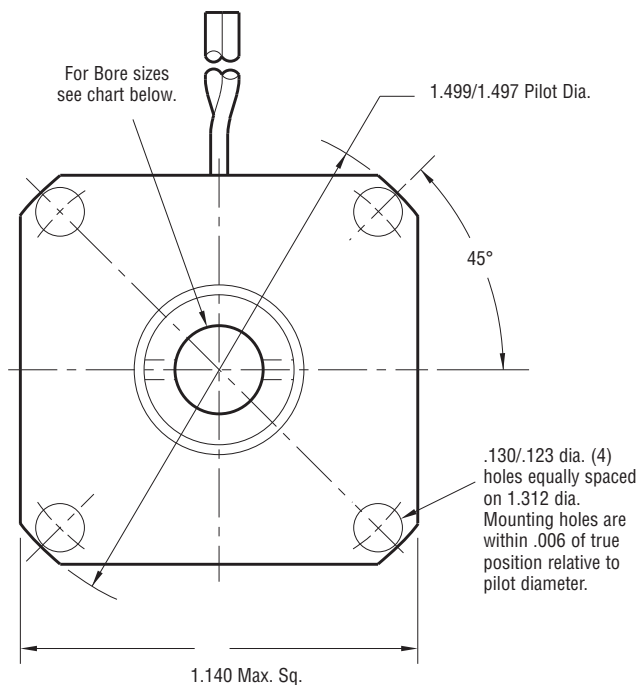

FIELD VIEW

Customer Shall Maintain:

1. Squareness of field mounting face with rotor shaft within .003 T.I.R. measured at pilot diameter
2. Concentricity of field mounting pilot diameter with rotor mounting shaft within .003 T.I.R.
3. Rotor and armature shafts in line within .003 T.I.R.

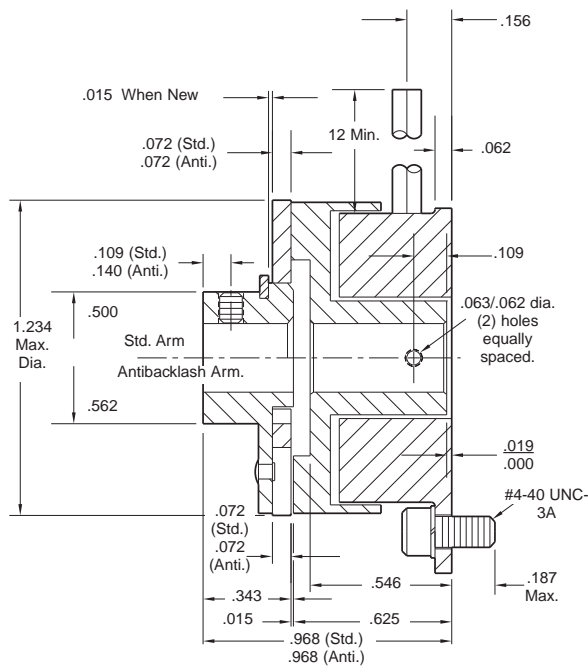

Bore Dimensions

Rotor Bore Dia.	Armature Bore Dia.
.188/.187	.188/.187
.251/.250	.251/.250
.313/.312	(.313/.312)*

*(Antibrake Armatures)

Static Torque	5 lb. in.
Maximum Speed	3,600 rpm
Standard Voltage	D.C. 6, 24, 90

All dimensions are nominal unless otherwise noted.

Information on inertia and weights begins on page 239. Coil data is on pages 250 and 251.

Drawing I-25503

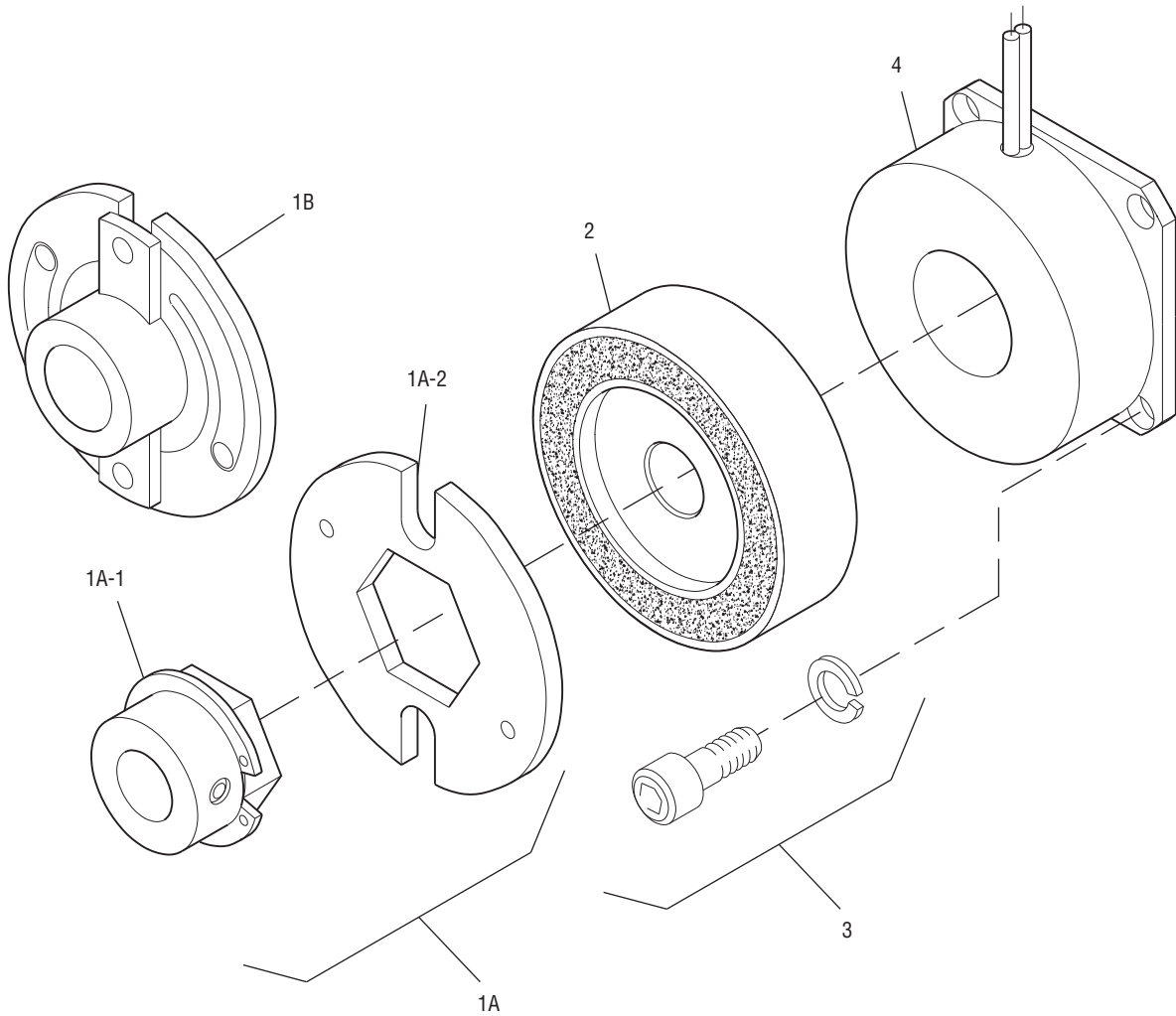

Item	Description	Part Number	Qty.
1A	Armature and Hub		
1A-1	Armature Hub		1
	3/16" Bore	5622-541-009	
	1/4" Bore	5622-541-008	
1A-2	Armature	110-0110	1
1B	Antibacklash Armature		1
	3/16" Bore	5622-111-004	
	1/4" Bore	5622-111-002	
	5/16" Bore	5622-111-003	
2	Rotor		1
	3/16" Bore	5602-751-004	
	1/4" Bore	5602-751-002	
	5/16" Bore	5602-751-003	
3	Mounting Accessory	5101-101-001	1
4	Field		1
	6 Volt	5602-451-003	
	24 Volt	5602-451-005	
	90 Volt	5602-451-007	

How to Order:

1. Specify Type of Armature Desired.
2. Specify Bore Size for Item 1A-1 or 1B and Item 2.
3. Specify Voltage for Item 4.
4. See Controls Section.

Example:

SFC-120 Clutch per I-25503 - 90 Volt
 Standard Armature
 1/4" Armature Hub Bore
 1/4" Rotor Bore

These units meet standards set forth in UL508 and are listed under guide card #NMTR2, file #59164.

These units are CSA certified under file #LR11543.

Refer to Service Manual P-200.