

Clutch Coupling

SFC-120 Bearing Mounted

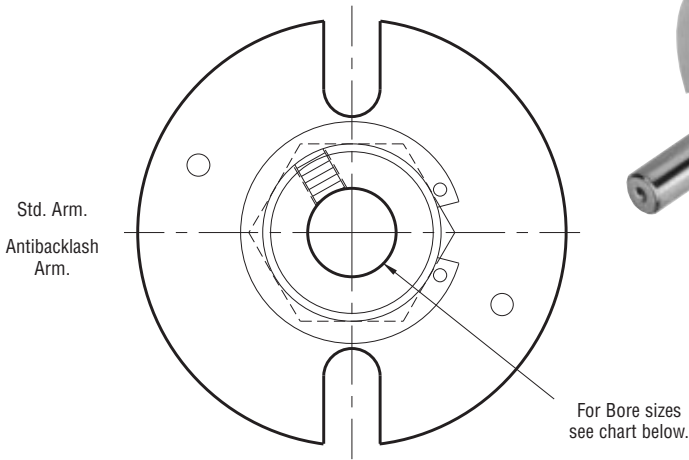

ARMATURE VIEW

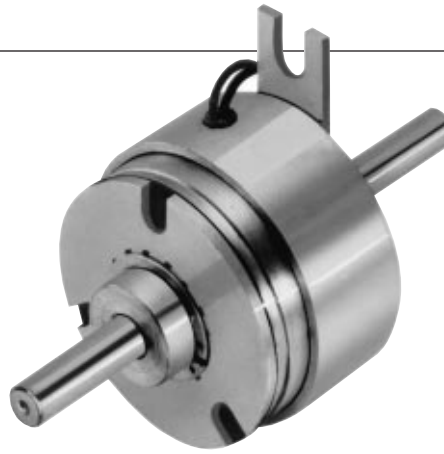
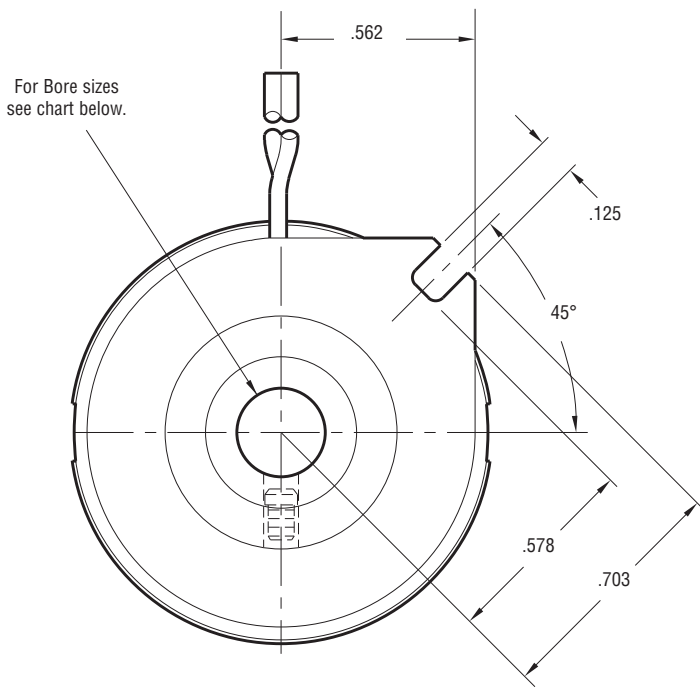

FIELD VIEW

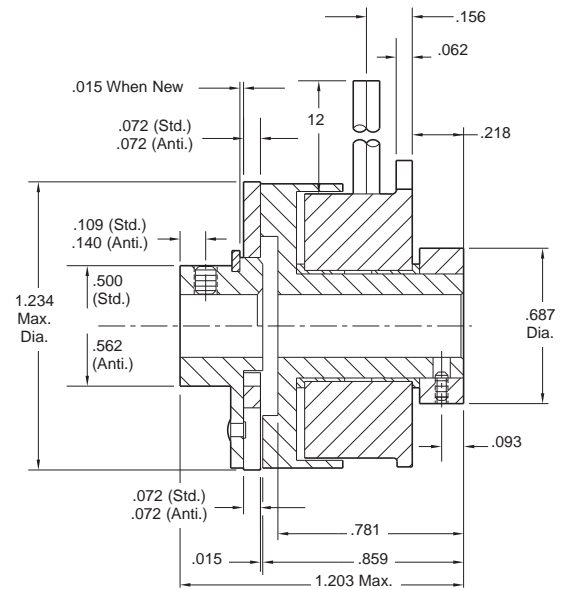

Bore Dimensions

Rotor Bore Dia.	Armature Bore Dia.
.188/.187	.188/.187
.251/.250	.251/.250
.313/.312	(.313/.312)*

*(Antibacklash Armatures)

Static Torque	5 lb. in.
Maximum Speed	3,600 rpm
Standard Voltage	D.C. 6, 24, 90

All dimensions are nominal unless otherwise noted.

Information on inertia and weights begins on page 239. Coil data is on pages 250 and 251.

Customer Shall Maintain:

1. Alignment between rotor and armature shafts to be .003 T.I.R.



Drawing I-25504

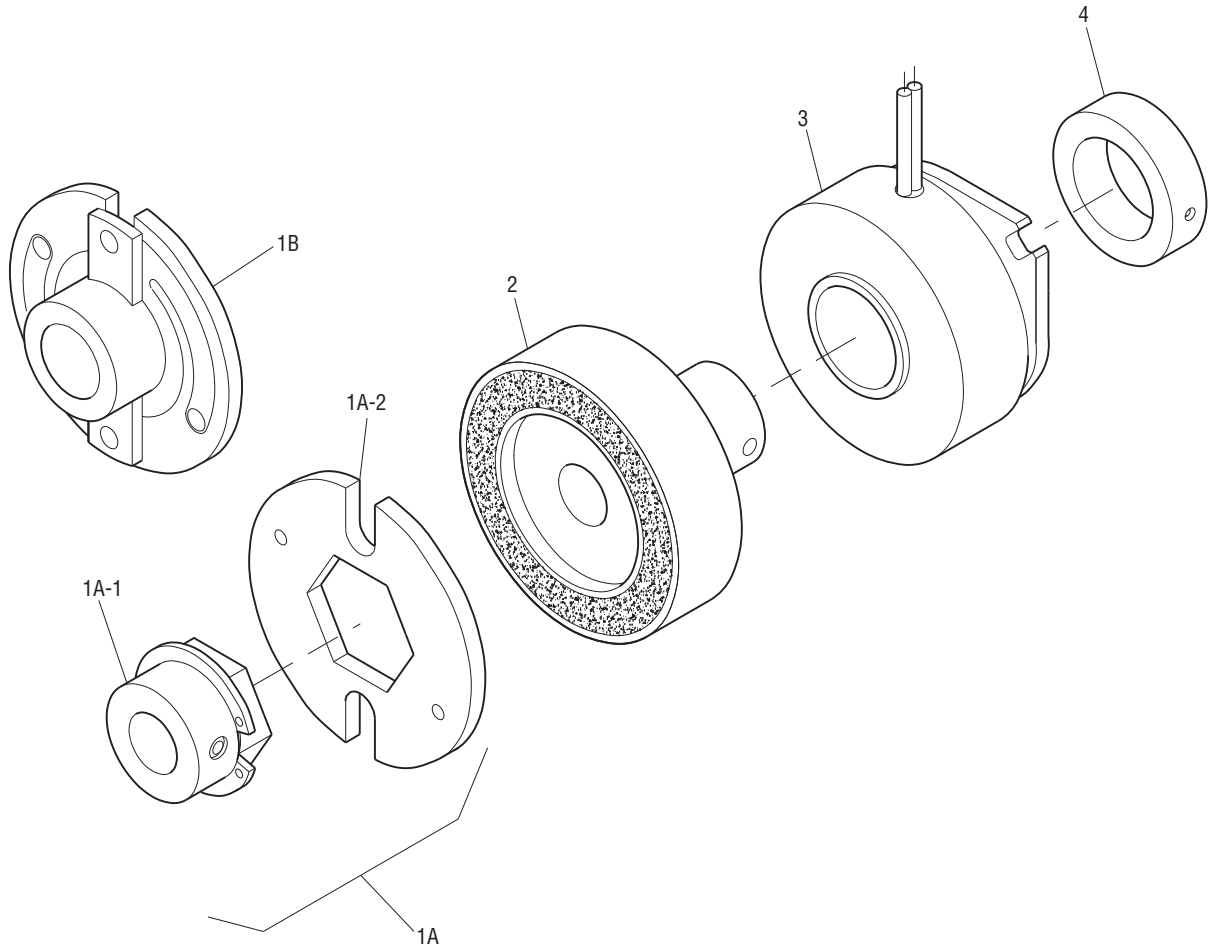

Item	Description	Part Number	Qty.
1A	Armature and Hub		
1A-1	Armature Hub		1
	3/16" Bore	5622-541-009	
	1/4" Bore	5622-541-008	
1A-2	Armature	110-0110	1
1B	Antibacklash Armature		1
	3/16" Bore	5622-111-004	
	1/4" Bore	5622-111-002	
	5/16" Bore	5622-111-003	
2	Rotor		1
	3/16" Bore	5602-751-008	
	1/4" Bore	5602-751-006	
	5/16" Bore	5602-751-007	
3	Field		1
	6 Volt	5602-451-021	
	24 Volt	5602-451-023	
	90 Volt	5602-451-025	
4	Set Collar	5602-266-001	1

How to Order:

1. Specify Type of Armature Desired.
2. Specify Bore Size for Item 1A-1 or 1B and Item 2.
3. Specify Voltage for Item 3.
4. See Controls Section.

Example:

SFC-120 Clutch per I-25504 - 90 Volt
Standard Armature
1/4" Armature Hub Bore

These units meet standards set forth in UL508 and are listed under guide card #NMTR2, file #59164.

These units are CSA certified under file #LR11543.

Refer to Service Manual P-200.