

# Clutch Coupling

## SFC-1000 Bearing Mounted

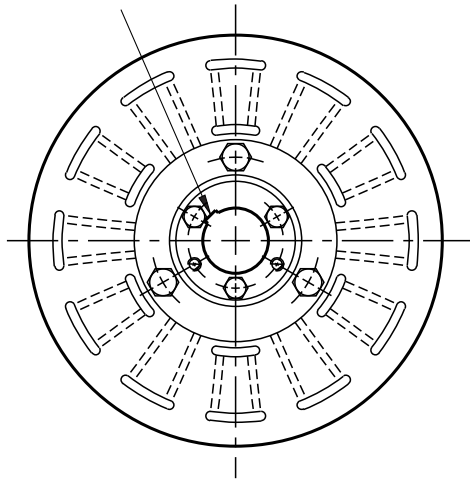

See page 252 for details on Bushings.



**ARMATURE VIEW**

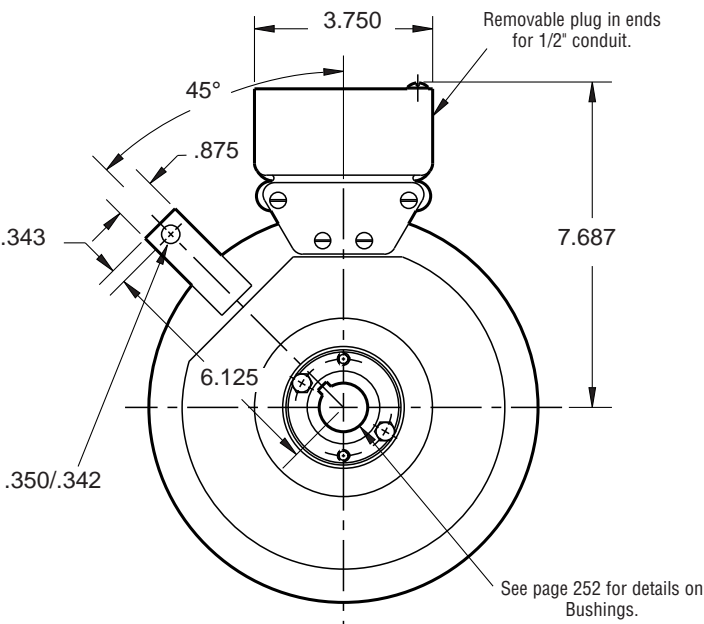

**FIELD VIEW**

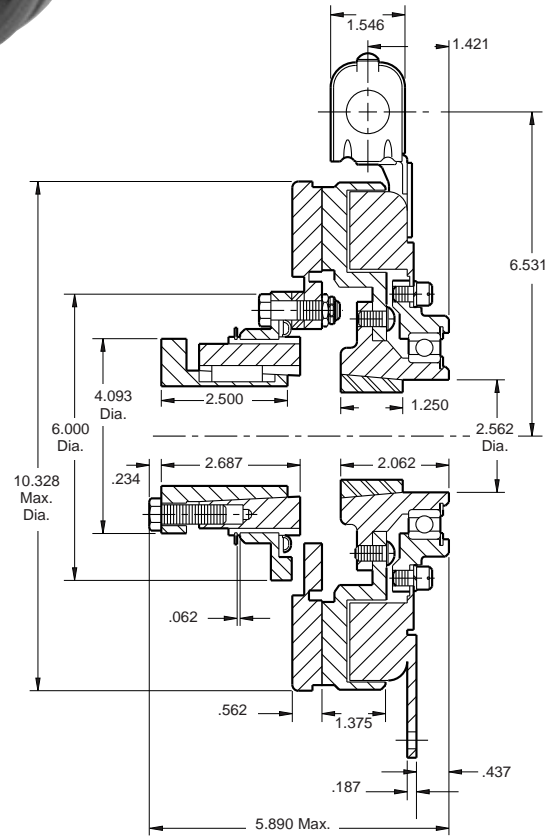

Armature Shaft	.750 – 2.687
Rotor Shaft	.500 – 2.000
Static Torque	240 lb. ft.
Maximum Speed	2,500 rpm
Standard Voltage	D.C. 6, 24, 90

**Customer Shall Maintain:**

1. Armature mounting shaft concentric with field and rotor mounting shaft within .006 T.I.R.
2. Angular alignment of shafts within 1/2 degree.

All dimensions are nominal unless otherwise noted.

Information on inertia and weights begins on page 239. Coil data is on pages 250 and 251.



Drawing I-25598

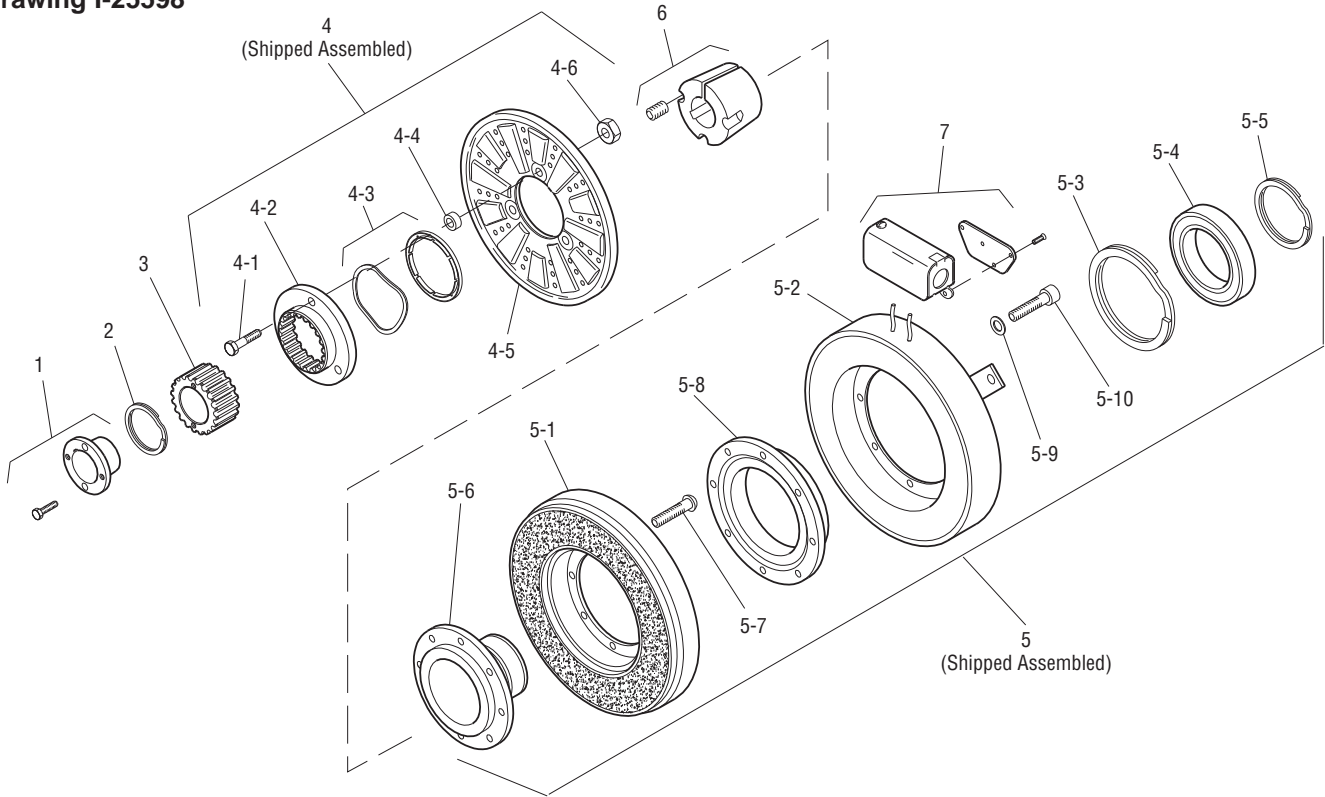

Item	Description	Part Number	Qty.
1	Bushing*		1
	3/4" to 2-11/16" Bore	180-0026 to 180-0057	
2	Retainer Ring	748-0007	1
3	Splined Hub	540-0062	1
4	Armature & Splined Adapter	5202-111-001	1
4-1	Capscrew	797-0341	3
4-2	Splined Adapter	104-0009	1
4-3	Autogap Accessory	5322-101-004	1
4-4	Spacer	748-0333	3
4-5	Armature	5322-111-036	1
4-6	Locknut	661-0004	3
5	Field & Rotor Assembly		1
	6 Volt	5202-452-012	
	24 Volt	5202-452-014	
	90 Volt	5202-452-015	
5-1	Rotor		1
	Standard Friction Material	5202-751-003	
	†Optional LK Facing	5202-751-007	
5-2	Field & Bearing Assembly		1
	6 Volt	5202-451-040	
	24 Volt	5202-451-042	
	90 Volt	5202-451-043	
5-3	Retainer Ring	748-0116	1
5-4	Ball Bearing	166-1046	1

Item	Description	Part Number	Qty.
5-5	Retainer Ring	748-0582	1
5-6	Rotor Hub	540-1300	1
5-7	Buttonhead Capscrew	797-1261	6
5-8	Ring Adapter	748-1047	1
5-9	Lockwasher	950-0359	6
5-10	Socket Head Capscrew	797-0422	6
6	Bushing*		1
	1/2" to 2" Bore	180-0155 to 180-0179	
7	Conduit Box	5200-101-012	1

**How to Order:**

1. Specify Bore Size for Items 1 and 6.
2. Specify Voltage for Item 5.
3. See Controls Section.

**Example:**

SFC-1000 Clutch Coupling per I-25598 - 90 Volt, 1" Bore

These units, when used in conjunction with the correct Warner Electric conduit box, meet the standards of UL508 and are listed under guide card #NMTR, file #59164. These units are CSA certified under file #LR11543.

\*See page 252 for specific part numbers.

Refer to Service Manual P-207.

†Optional LK facing available. For more information, see page 232.