

# Clutch

## SF-650 Flange Mounted

See page 230 for details on Drive Pin mountings.

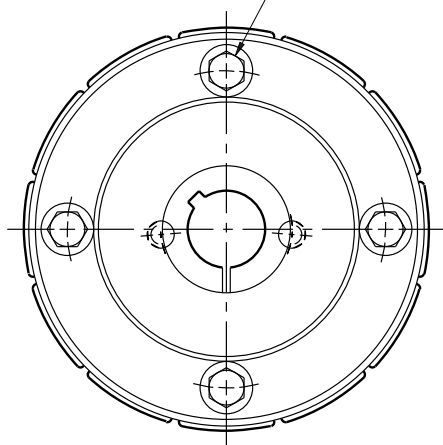

**ARMATURE VIEW**

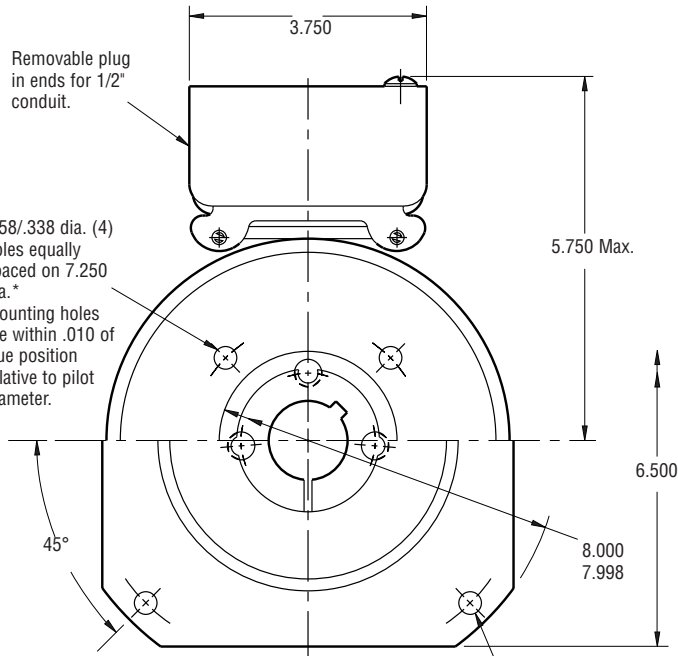
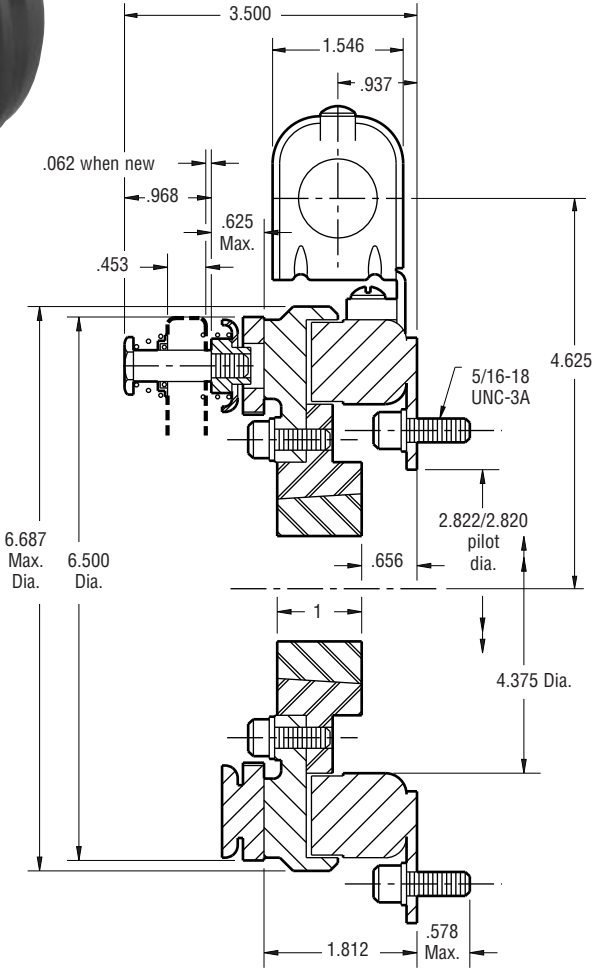
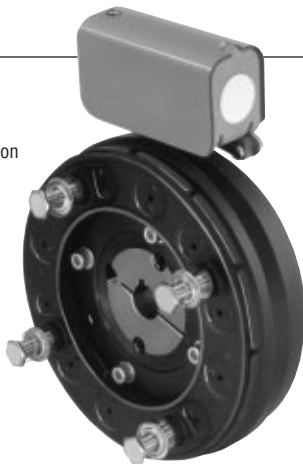

**FIELD VIEW**

(Inside & Outside Mounted)

**Customer Shall Maintain:**

1. Concentricity of field mounting pilot diameter with rotor mounting shaft within .006 T.I.R.
2. Squareness of field mounting face with shaft within .006 T.I.R. measured at field mounting bolt circle.
3. Rotor mounting pilot diameter must be concentric with shaft within .006 T.I.R.

Shaft Size	.500 – 1.625
Static Torque	95 lb.ft.
Maximum Speed	3,600 rpm
Standard Voltage	D.C. 6, 24, 90

All dimensions are nominal unless otherwise noted.  
 Information on inertia and weights begins on page 239. Coil data is on pages 250 and 251.



Drawing I-25749

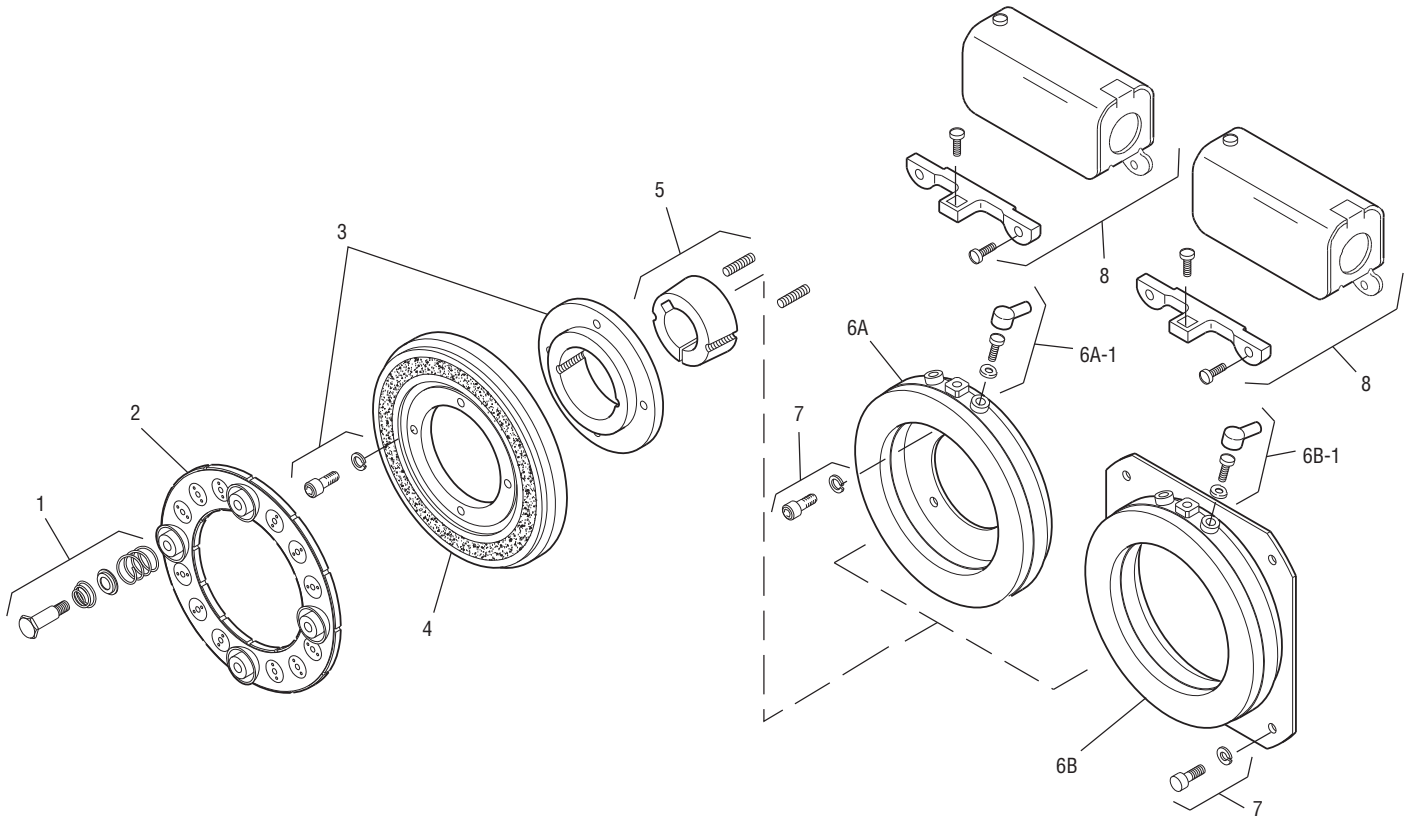

Item	Description	Part Number	Qty.
1	Armature Accessory	5181-101-010	4
2	Armature	5281-111-002	1
3	Rotor Hub & Mounting Acc.	5207-101-005	1
4	Rotor	5281-751-001	1
5	Bushing*		1
	1/2" to 1-5/8" Bore	180-0326 to 180-0344	
6A	Field - Inside Mounted		1
	6 Volt	5207-451-009	
	24 Volt	5207-451-012	
	90 Volt	5207-451-011	
6A-1	Terminal Accessory	5311-101-001	1
6B	Field - Outside Mounted		1
	6 Volt	5207-451-003	
	24 Volt	5207-451-006	
	90 Volt	5207-451-005	
6B-1	Terminal Accessory	5311-101-001	1
7	Mounting Accessory	5321-101-002	1
8	Conduit Box	5200-101-010	1

**How to Order:**

1. Specify Bore Size for Item 5.
2. Specify Voltage for Item 6.
3. Specify Inside or Outside Mounted for Item 6.
4. See Controls Section.

**Example:**

SF-650 Clutch per I-25749 - 90 Volt  
1" Bore

These units, when used in conjunction with the correct Warner Electric conduit box, meet the standards of UL508 and are listed under guide card #NMTR, file #59164.

These units are CSA certified under file #LR11543

\*See page 252 for specific part numbers.

Refer to Service Manual P-202.