

Clutch

SF-650 Bearing Mounted

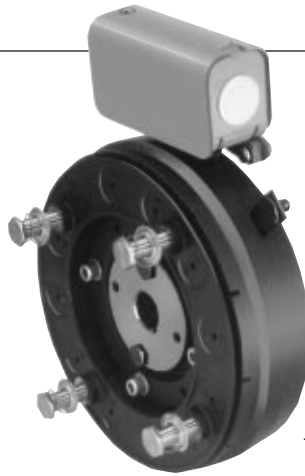

See page 230 for details on Drive Pin mountings.

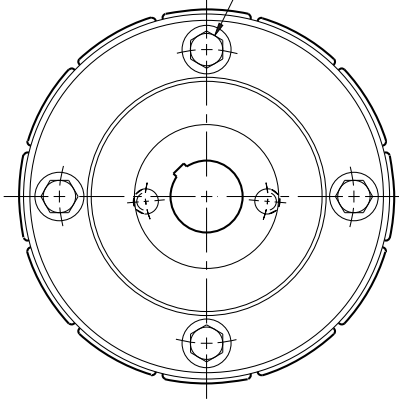

ARMATURE VIEW

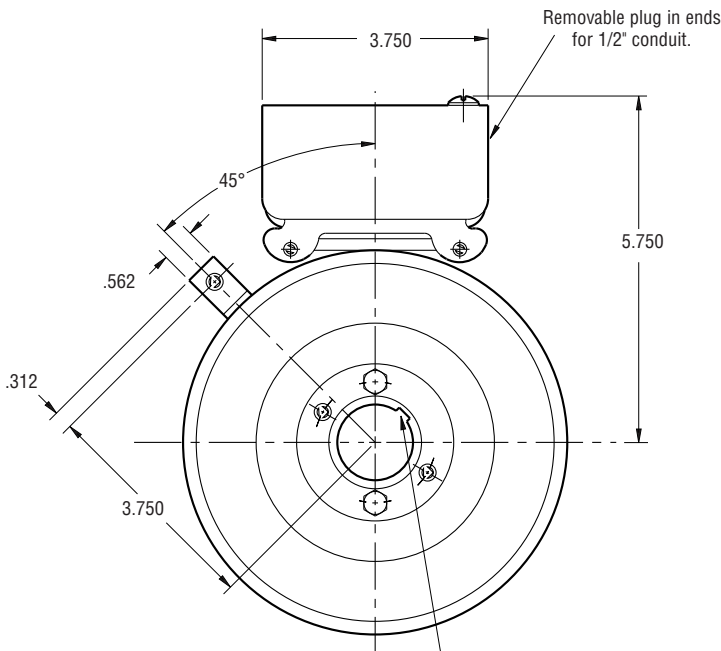

See page 252 for details on Bushings.

FIELD VIEW

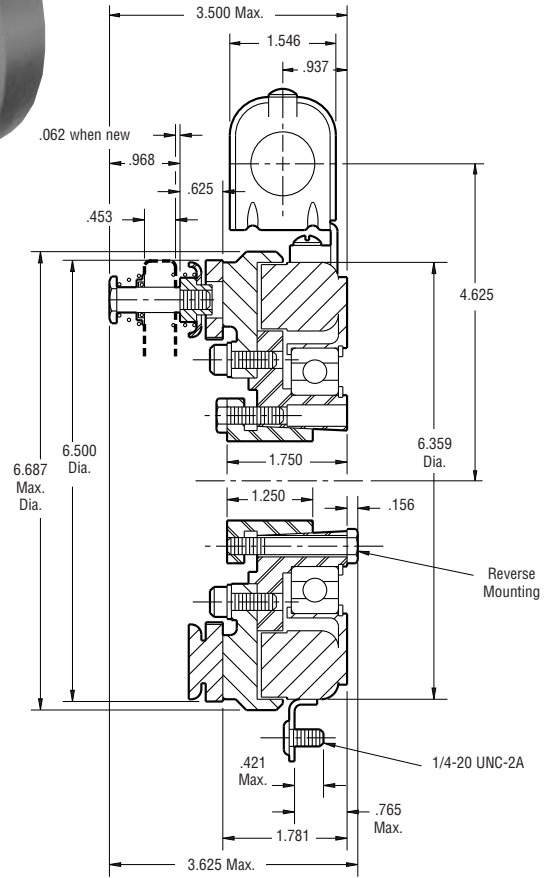

Shaft Size	.500 – 1.500
Static Torque	95 lb.ft.
Maximum Speed	3,600 rpm
Standard Voltage	D.C. 6, 24, 90

All dimensions are nominal unless otherwise noted.

Information on inertia and weights begins on page 239. Coil data is on pages 250 and 251.



Drawing I-25750

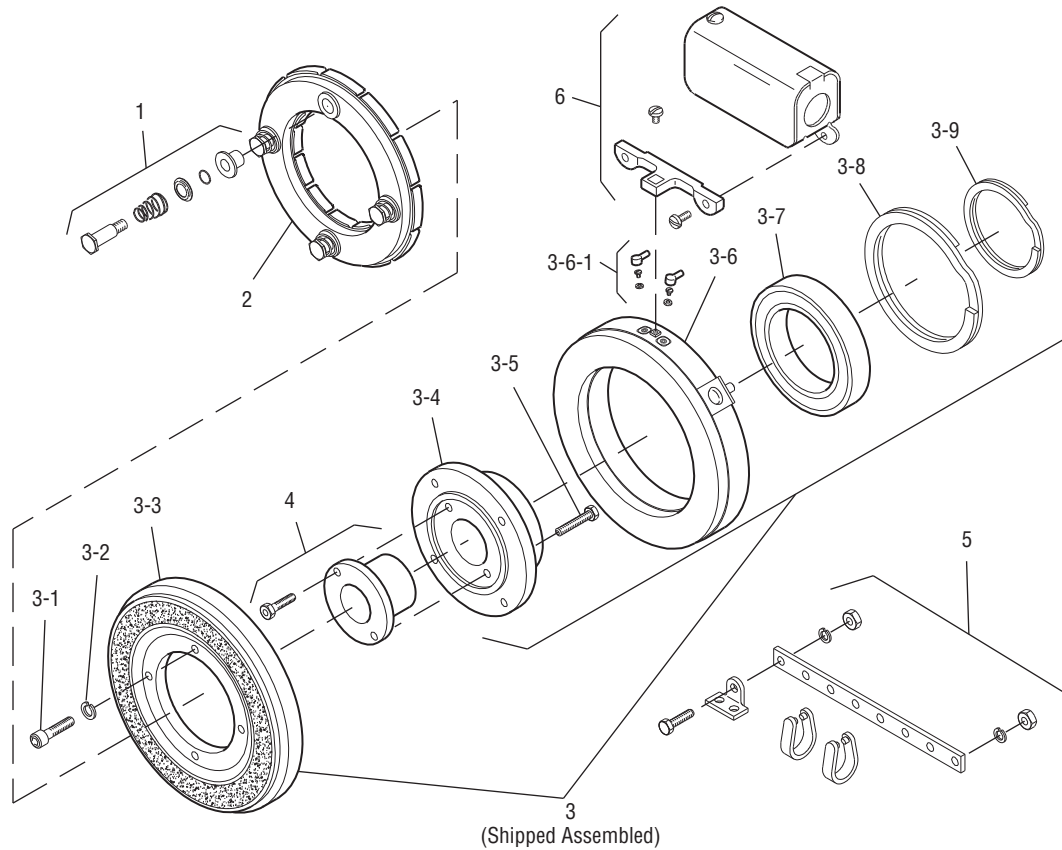

Item	Description	Part Number	Qty.
1	Autogap Accessory	5181-101-010	4
2	Armature	5281-111-002	1
3	Field and Rotor Assembly		1
	6 Volt	5207-452-002	
	24 Volt	5207-452-005	
	90 Volt	5207-452-004	
3-1	Capscrew	797-0083	4
3-2	Lockwasher	950-0355	4
3-3	Rotor Assembly	5281-751-001	1
3-4	Rotor Hub	540-0614	1
3-5	Reverse Mounting Accessory	5201-101-005	1
3-6	Field		1
	6 Volt	5281-451-002	
	24 Volt	5281-451-004	
	90 Volt	5281-451-005	
3-6-1	Terminal Accessory	5311-101-001	1
3-7	Ball Bearing	166-0104	1
3-8	Retainer Ring - External	748-0004	1
3-9	Retainer Ring -Internal	748-0104	1

Item	Description	Part Number	Qty.
4	Bushing*		1
	1/2" to 1-1/2" Bore	180-0002 to 180-0018	
†5	Torque Arm Accessory	5207-101-003	1
6	Conduit Box	5200-101-010	1

How to Order:

1. Specify Voltage for Item 3.
2. Specify Bore Size for Item 4.
3. See Controls Section.

Example:

SF-650 Clutch, bearing mounted per I-25750 - 90 Volt, 1" Bore

These units, when used in conjunction with the correct Warner Electric conduit box, meet the standards of UL508 and are listed under guide card #NMTR, file #59164.

These units are CSA certified under file #LR11543

*See page 252 for specific part numbers.

Refer to Service Manual P-202.

†Optional – not included in price.