

# Clutch

## SF-250 Flange Mounted

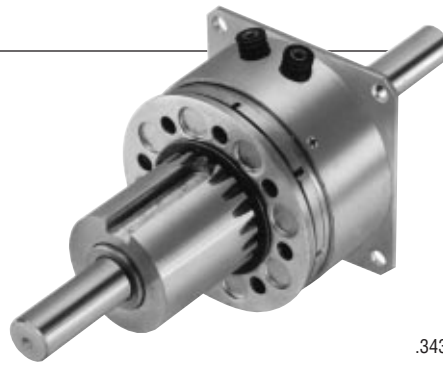

For Bore & Keyway sizes see chart below.

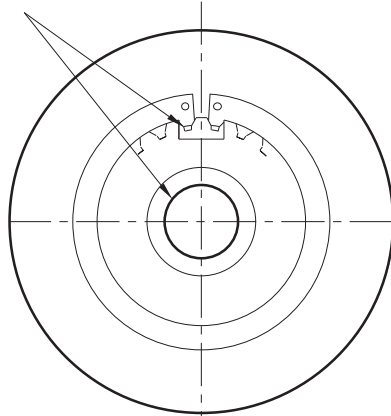

**ARMATURE VIEW**

For Bore & Keyway sizes see chart below.

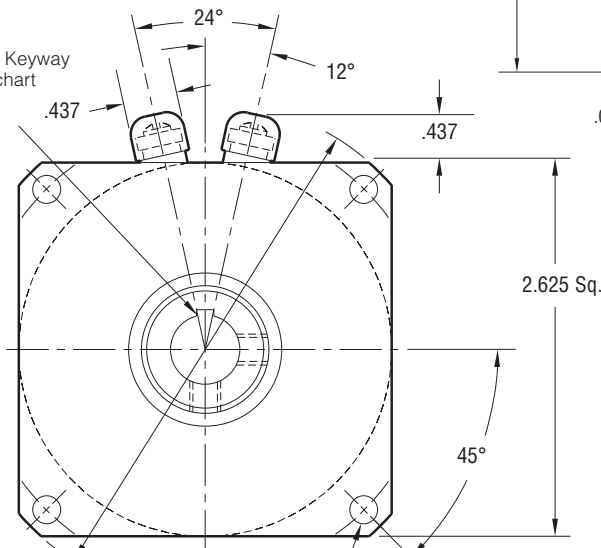

**FIELD VIEW**

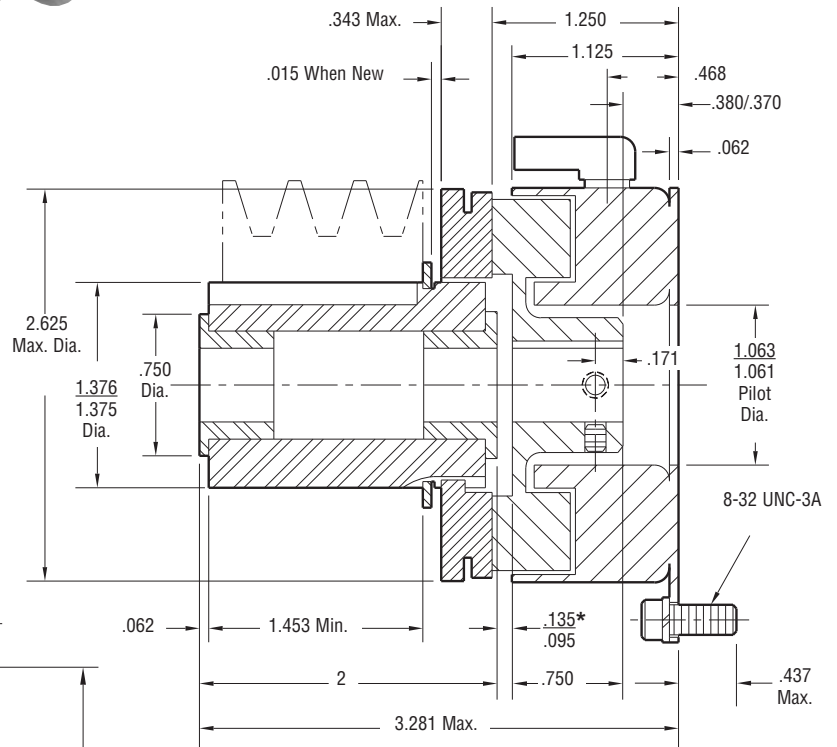

\*Customer shall maintain dimension as noted.

### Bore and Keyway Dimensions

Armature Bore Dia.	Keyway	Rotor Bore Dia.	Keyway
.3750/.3745		.376/.375	.093 x .046
.5000/.4995	.312 x .156	.438/.437	.125 x .031
*.5625/.5620	x 1.250	.501/.500	.125 x .031
.6250/.6245			

\*Available on special order only.

Static Torque	70 lb.in.
Maximum Speed	7,500 rpm
Standard Voltage	D.C. 6, 24, 90

All dimensions are nominal unless otherwise noted. Information on inertia and weights begins on page 239. Coil data is on pages 250 and 251.

### Customer Shall Maintain:

1. Squareness of field mounting face with shaft within .003 T.I.R. measured at pilot diameter.
2. Concentricity of field mounting pilot diameter with rotor mounting shaft within .003 T.I.R.

\*Mounting holes are within .010 of true position relative to pilot diameter.



Drawing I-25520

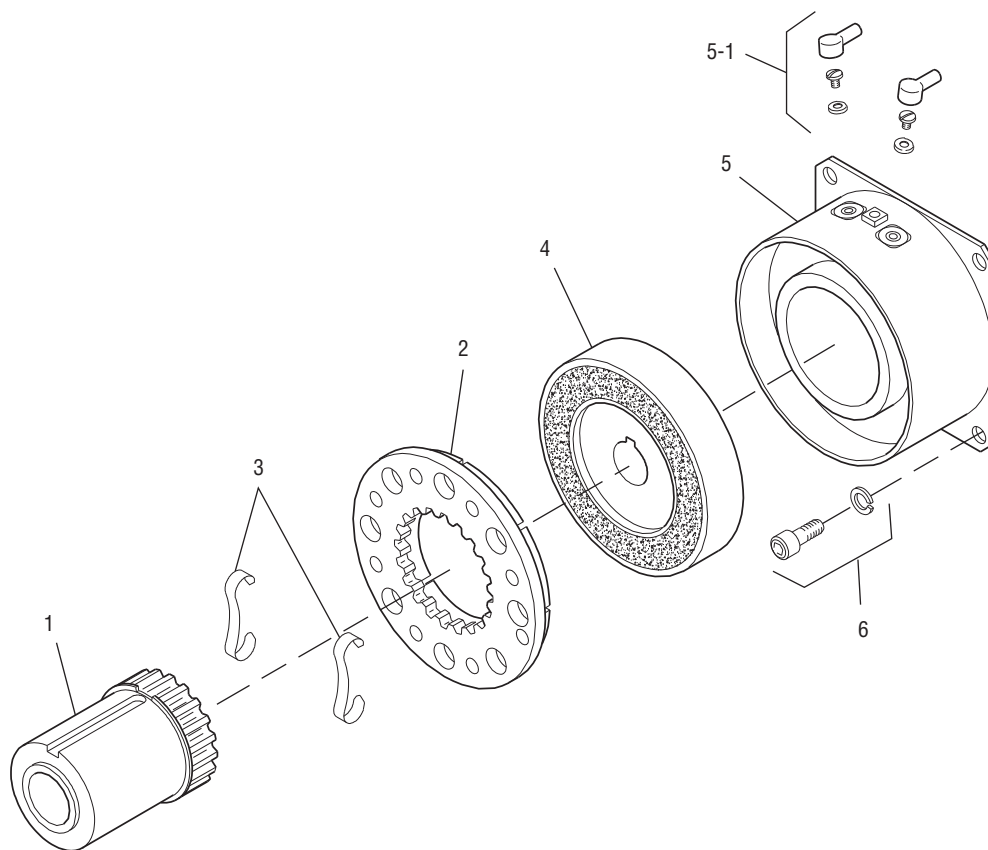

Item	Description	Part Number	Qty.
1	Armature Hub		1
	3/8" Bore	5124-541-002	
	1/2" Bore	5124-541-003	
	5/8" Bore	5124-541-005	
2	Armature	5124-111-001	1
3	Release Spring	5103-101-003	1
4	Rotor		1
	3/8" Bore	5103-751-008	
	1/2" Bore	5103-751-010	
5	Field		1
	6 Volt	5103-451-002	
	24 Volt	5103-451-004	
	90 Volt	5103-451-007	
5-1	Terminal Accessory	5103-101-002	1
6	Mounting Accessory	5102-101-001	1

**How to Order:**

1. Specify Bore Size for Item 1 and Item 4.
2. Specify Voltage for Item 5.
3. See Controls Section.

**Example:**

SF-250 Clutch per I-25520 - 90 Volt  
 3/8" Armature Hub Bore  
 3/8" Rotor Bore

These units meet standards set forth in UL508 and are listed under guide card #NMTR2, file #59164.

These units are CSA certified under file #LR11543.

Refer to Service Manual P-200.