

Clutch

SF-250 Bearing Mounted

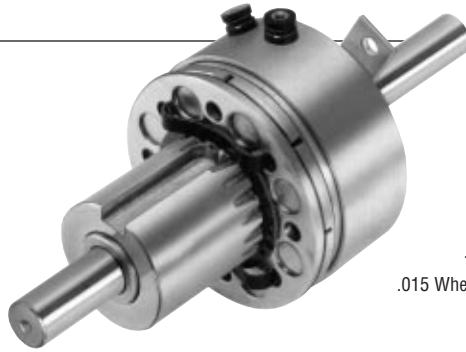

For Bore & Keyway sizes see chart below.

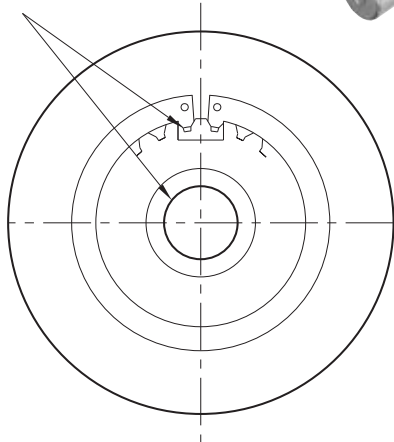

ARMATURE VIEW

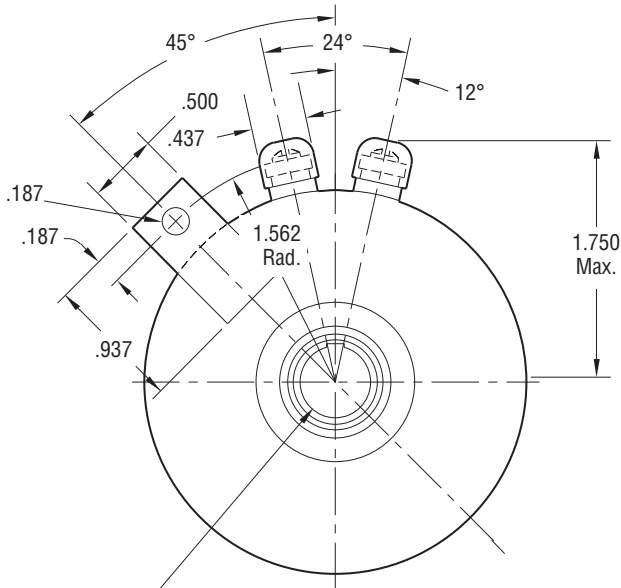

For Bore & Keyway sizes see chart below.

FIELD VIEW

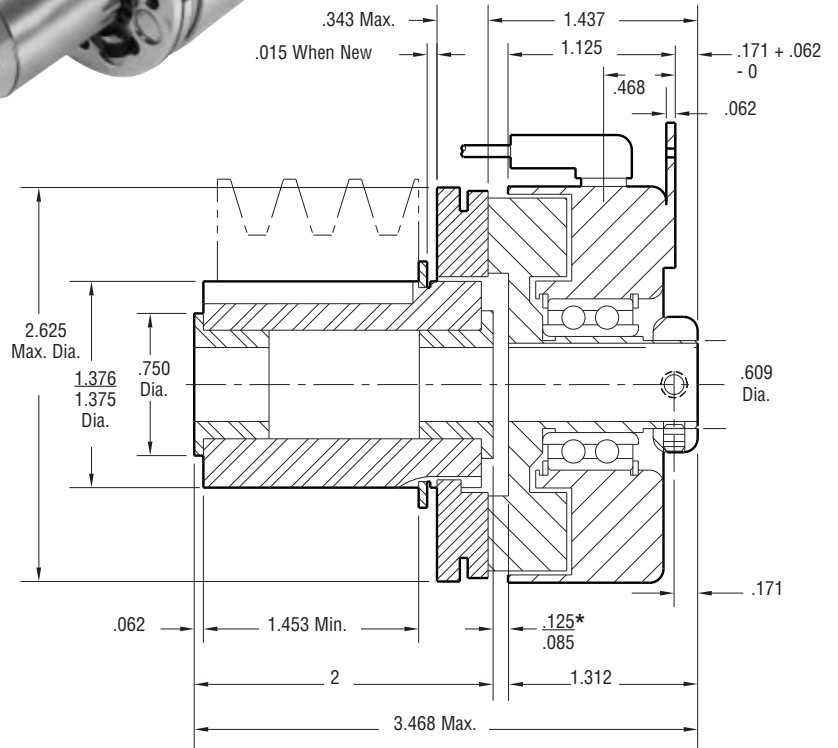

*Customer shall maintain dimension as noted.

Bore and Keyway Dimensions

Armature Bore Dia.	Keyway	Rotor Bore Dia.	Keyway
.3750/.3745		.376/.375	.093 x .046
.5000/.4995	.312 x .156	.438/.437*	.125 x .062
.5625/.5620*	x 1.25	.501/.500	.125 x .062
.6250/.6245			

* Available on special order only.

Static Torque	70 lb.in.
Maximum Speed	7,500 rpm
Standard Voltage	D.C. 6, 24, 90

All dimensions are nominal unless otherwise noted.

Information on inertia and weights begins on page 239. Coil data is on pages 250 and 251.



SF-250 Bearing Mounted

Drawing I-25521

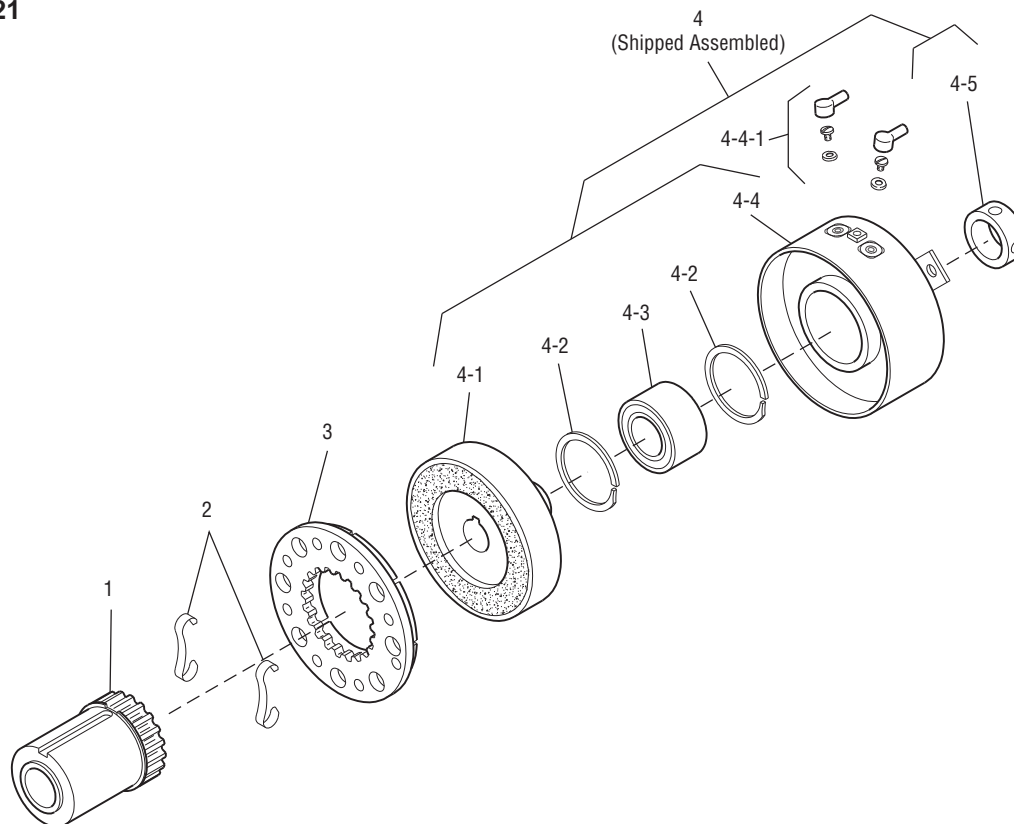

Item	Description	Part Number	Qty.
1	Armature Hub		1
	3/8" Bore	5124-541-002	
	1/2" Bore	5124-541-003	
	5/8" Bore	5124-541-005	
2	Release Spring Optional	5103-101-003	1
3	Armature	5124-111-001	1
4	Field and Rotor Assembly		1
	6 Volt – 3/8" Bore	5103-452-002	
	24 Volt – 3/8" Bore	5103-452-004	
	90 Volt – 3/8" Bore	5103-452-007	
	6 Volt – 1/2" Bore	5103-452-016	
	24 Volt – 1/2" Bore	5103-452-018	
	90 Volt – 1/2" Bore	5103-452-021	
4-1	Rotor		1
	3/8" Bore	5103-751-014	
	1/2" Bore	5103-751-016	
4-2	Retainer Ring	748-0371	2
4-3	Ball Bearing	166-0108	1
4-4	Field		1
	6 Volt	5103-451-018	
	24 Volt	5103-451-020	
	90 Volt	5103-451-023	
4-4-1	Terminal Accessory	5103-101-002	1
4-5*	Set Collar	266-0005	1

*Used with 1/2" Bore only.

How to Order:

1. Specify Bore Size for Item 1 and Item 4.
2. Specify Voltage for Item 4.
3. See Controls Section.

Example:

SF-250 Clutch per I-25521 - 90 Volt
 1/2" Armature Hub Bore
 1/2" Rotor Bore

These units meet standards set forth in UL508 and are listed under guide card #NMTR2, file #59164.

These units are CSA certified under file #LR11543.

Refer to Service Manual P-200.