

# Clutch

## SF-170 Flange Mounted

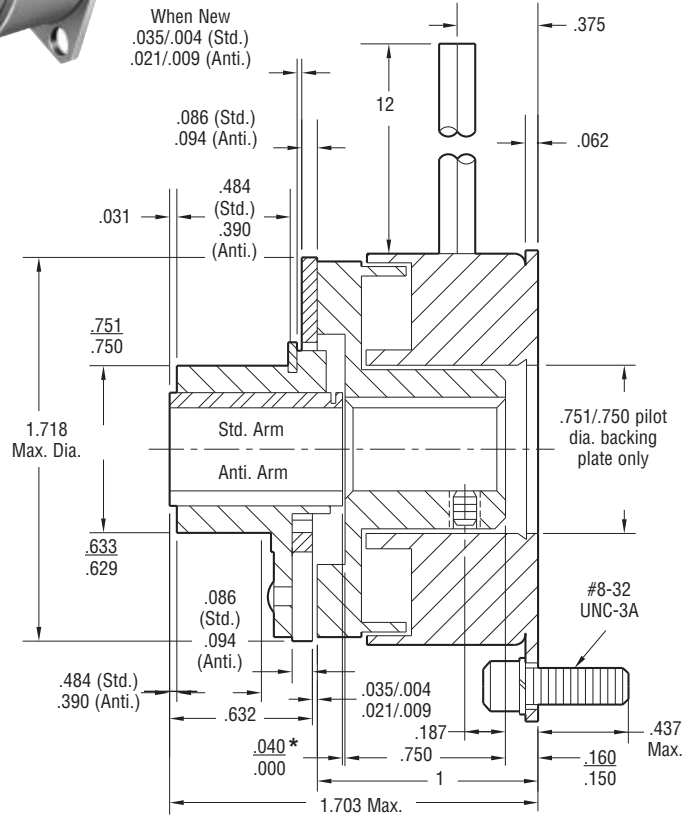
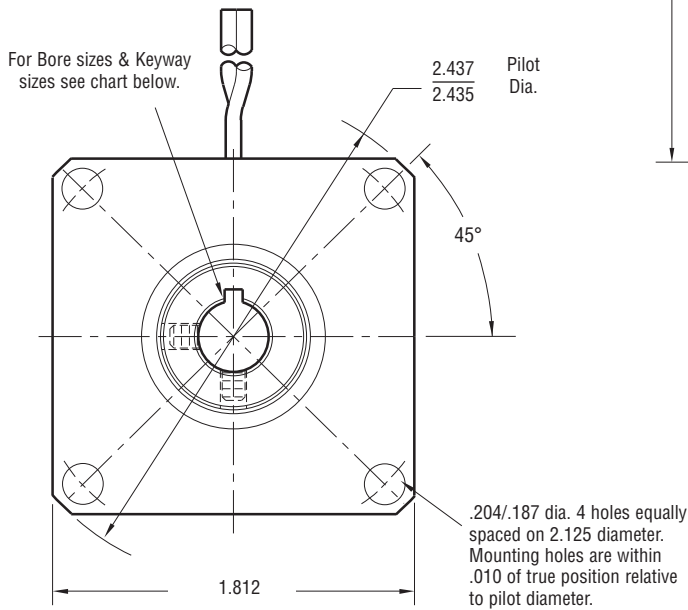
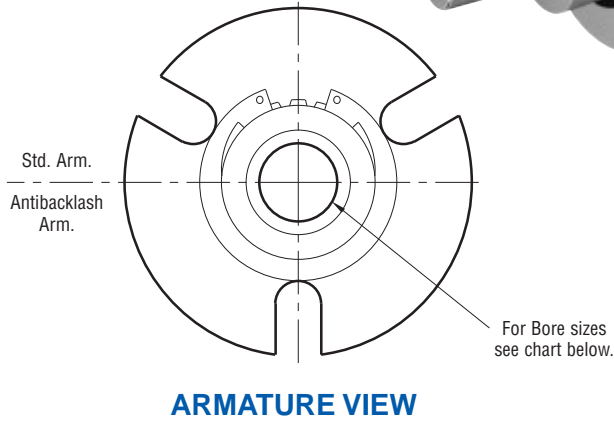
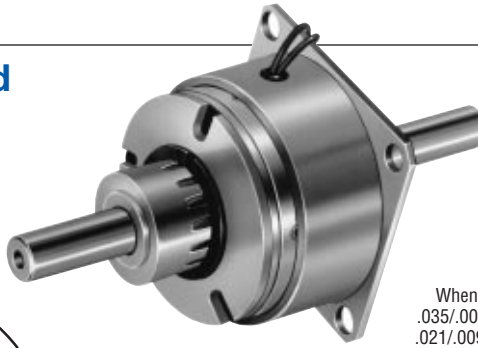

\*Diameter over knurl.

### Rotor Bore Dimensions

Rotor Bore Dia.	Keyway	Armature Bore Dia.
.251/.250	.062/.031	.2522/.2507
.313/.312	.062/.031	.3145/.3130
.376/.375	.093/.047	.3773/.3755

Static Torque	15 lb.in.
Maximum Speed	5,000 rpm
Standard Voltage	D.C. 6, 24, 90

All dimensions are nominal unless otherwise noted.

Information on inertia and weights begins on page 239. Coil data is on pages 250 and 251.

### Customer Shall Maintain:

1. Squareness of field mounting face with shaft with .003 T.I.R. measured at pilot diameter.
2. Concentricity of field mounting pilot diameter with rotor mounting shaft within .003 T.I.R.



Drawing I-25754

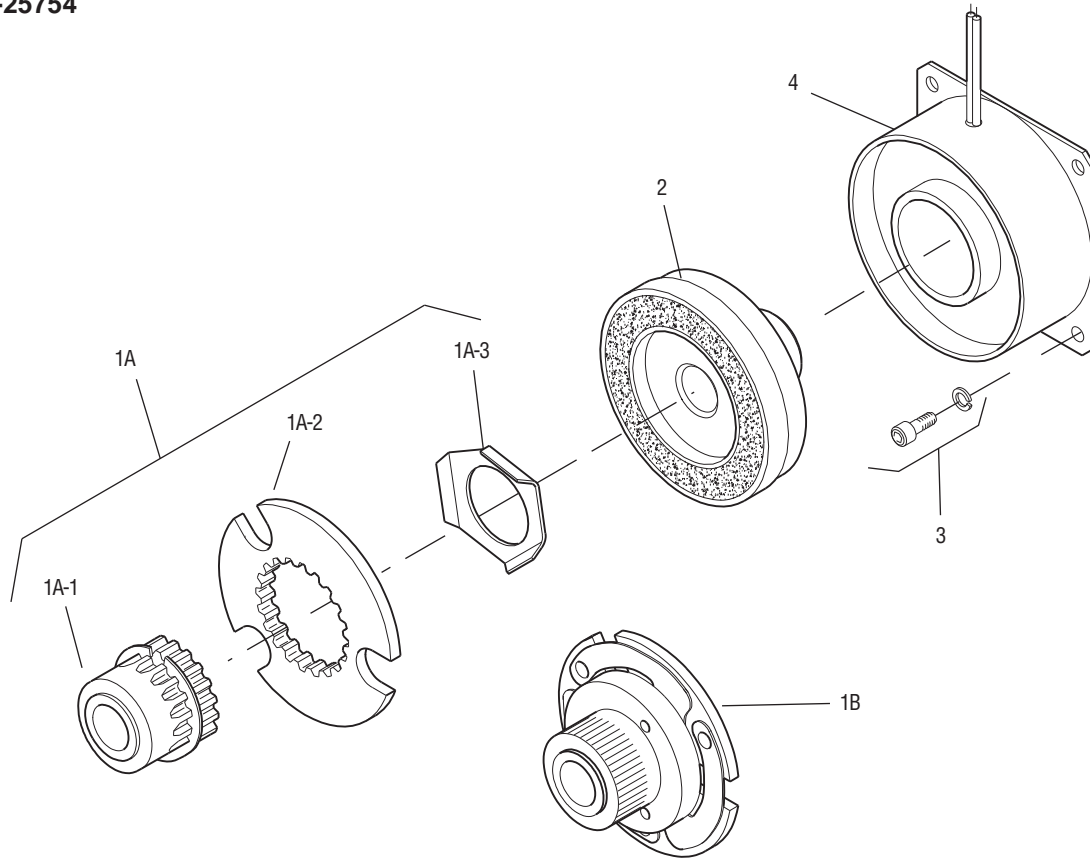

Item	Description	Part Number	Qty.
1A	Armature and Hub		
1A-1	Armature Hub		1
	1/4" Bore	5123-541-002	
	5/16" Bore	5123-541-003	
	3/8" Bore	5123-541-004	
1A-2	Armature	110-0111	1
1A-3	Release Spring	808-0019	1
1B	Antibacklash Armature		1
	1/4" Bore	5603-111-033	
	5/16" Bore	5603-111-034	
	3/8" Bore	5603-111-035	
2	Rotor		1
	1/4" Bore	5603-751-028	
	5/16" Bore	5603-751-029	
	3/8" Bore	5603-751-030	
3	Mounting Accessory	5102-101-001	1
4	Field		1
	6 Volt	5603-451-047	
	24 Volt	5603-451-049	
	90 Volt	5603-451-051	

**How to Order:**

1. Specify Type of Armature Desired.
2. Specify Bore Size for Item 1A-1 or 1B and Item 2.
3. Specify Voltage for Item 4.
4. See Controls Section.

**Example:**

SF-170 Clutch per I-25754 - 90 Volt  
 Antibacklash Armature  
 1/4" Armature Hub Bore  
 1/4" Rotor Bore

These units meet standards set forth in UL508 and are listed under guide card #NMTR2, file #59164.

These units are CSA certified under file #LR11543.

Refer to Service Manual P-200.