

Clutch, Hi-Torque

SF-1525 H.T. Flange Mounted

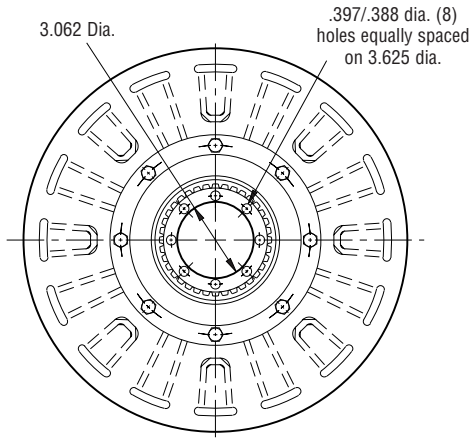

ARMATURE VIEW

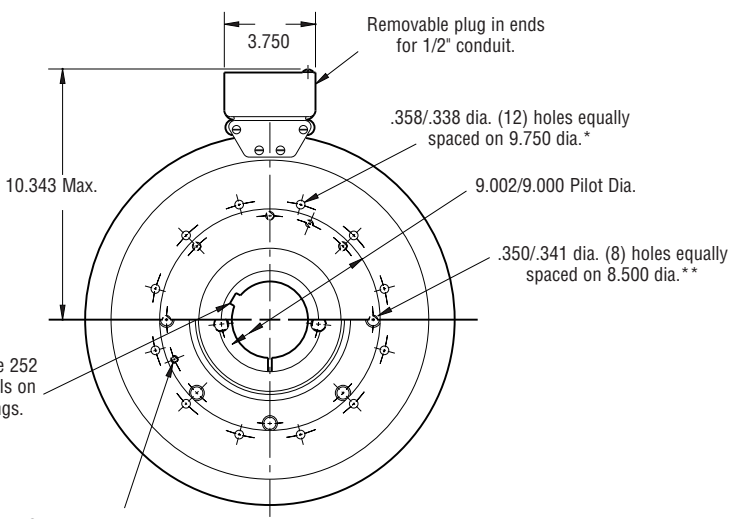

FIELD VIEW

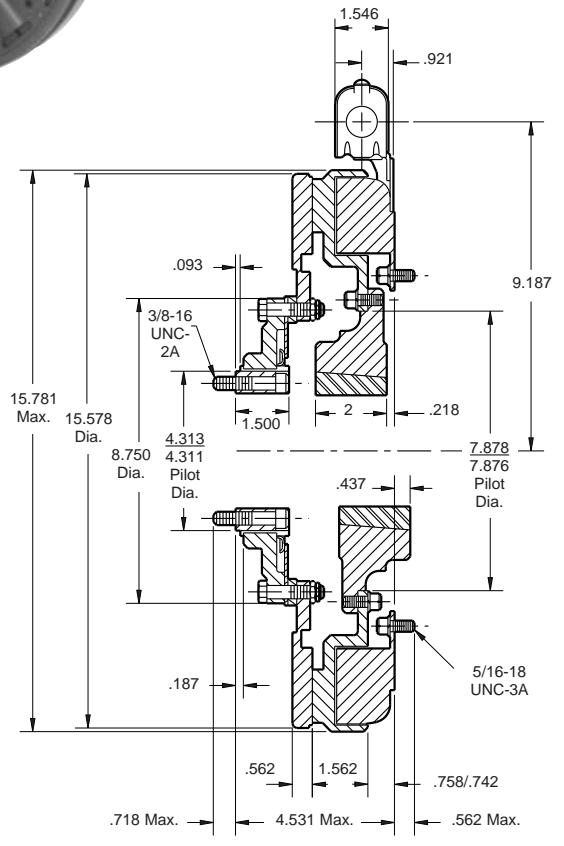

Customer Shall Maintain:

1. Concentricity of field mounting pilot diameter with rotor mounting shaft within .006 T.I.R.
2. Squareness of field mounting face with rotor mounting shaft within .006 T.I.R. measured at field mounting bolt circle.
3. Rotor mounting shaft concentric with armature center of rotation within .006 T.I.R.
4. Armature hub pilot diameter to be concentric with armature center of rotation within .010 T.I.R.

* Mounting holes are within .010 of true position relative to pilot diameter.

** Mounting holes are within .008 of true position relative to pilot diameter.

When Hub is Furnished by Customer:

Rotor mounting pilot diameter must be concentric with rotor mounting shaft within .006 T.I.R.

Shaft Size	.937– 3.000
Static Torque	1,350 lb.ft.
Maximum Speed	2,000 rpm
Standard Voltage	D.C. 6, 90

All dimensions are nominal unless otherwise noted.

Information on inertia and weights begins on page 239. Coil data is on pages 250 and 251.



Drawing I-25627

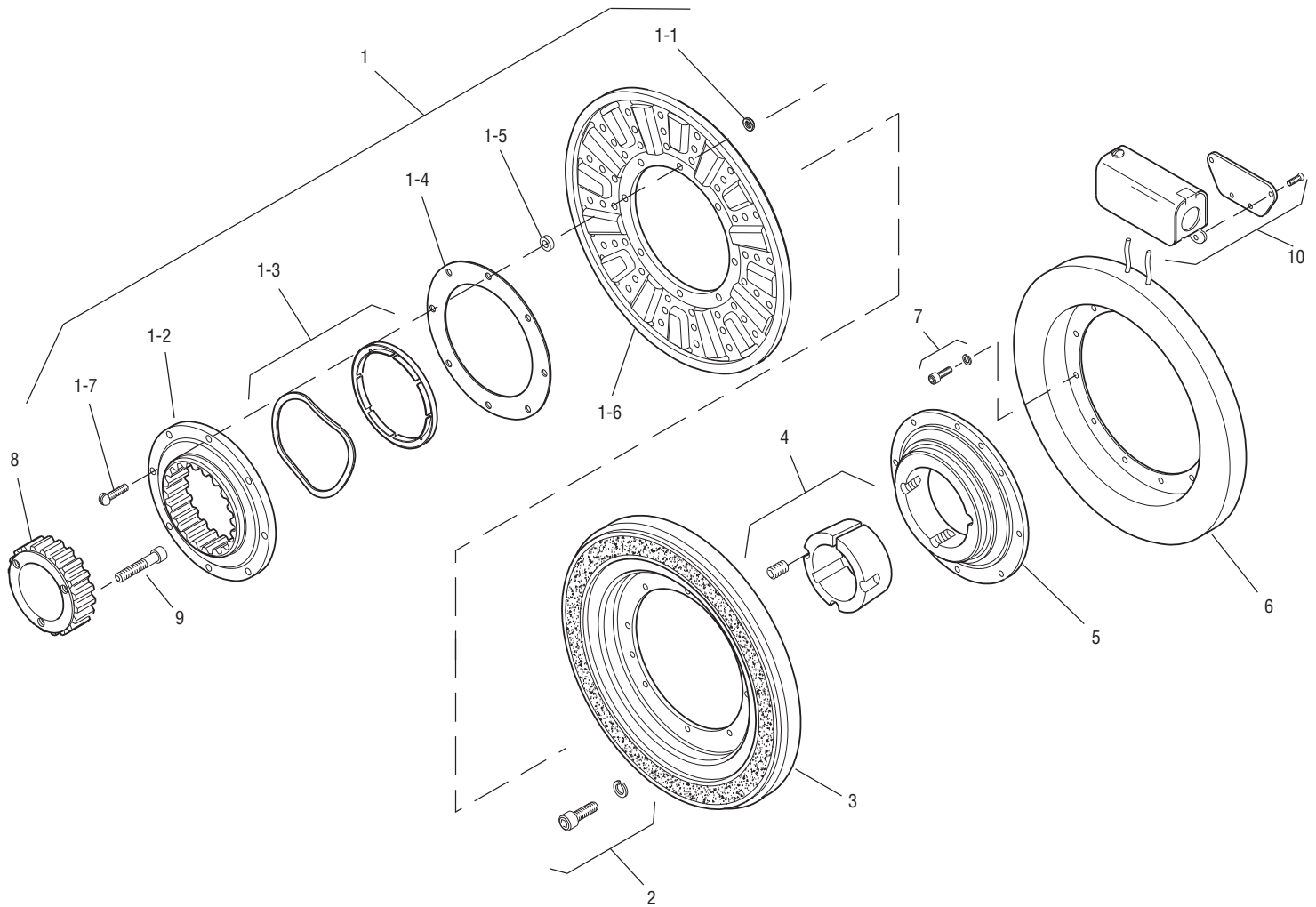

Item	Description	Part Number	Qty.
1	Armature Assembly	5204-111-004	1
1-1	Locknut	661-0004	8
1-2	Splined Adapter	104-0011	1
1-3	Autogap Accessory	5323-101-002	1
1-4	Retainer Plate	686-0003	1
1-5	Spacer	748-0333	8
1-6	Armature	5324-111-034	1
1-7	Screw	797-0342	8
2	Mounting Accessory	5321-101-002	2
3	Rotor	5204-751-001	1
4	Bushing*		
	15/16" to 3" Bore	180-0223 to 180-0256	1
5	Rotor Hub	540-0004	1
6	Field - Inside Mounted		1
	6 Volt	5204-451-005	
	90 Volt	5204-451-006	

Item	Description	Part Number	Qty.
7	Mounting Accessory - I.M.	5321-101-001	2
8	Splined Hub	540-0148	1
9	Mounting Accessory	5202-101-001	1
10	Conduit Box	5200-101-012	1

How to Order:

1. Specify Bore Size of Item 4.
2. See Controls Section.

Example:

SF-1525 Clutch, Hi-Torque, per I-25627 - 90 Volt, 2" Bore
 These units, when used in conjunction with the correct Warner Electric conduit box, meet the standards of UL508 and are listed under guide card #NMTR, file #59164. These units are CSA certified under file #LR11543.

*See page 252 for specific part numbers.

Refer to Service Manual P-215.