

SF-1525 Flange Mounted

See page 230 for details on Drive Pin mountings.

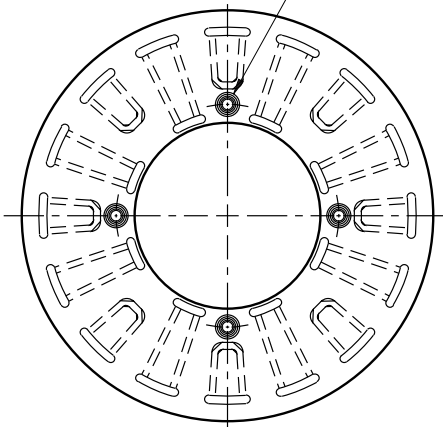

ARMATURE VIEW

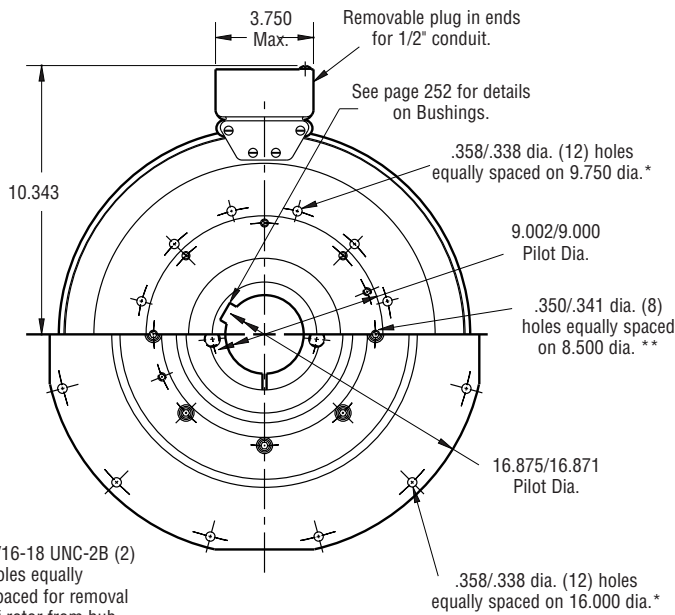
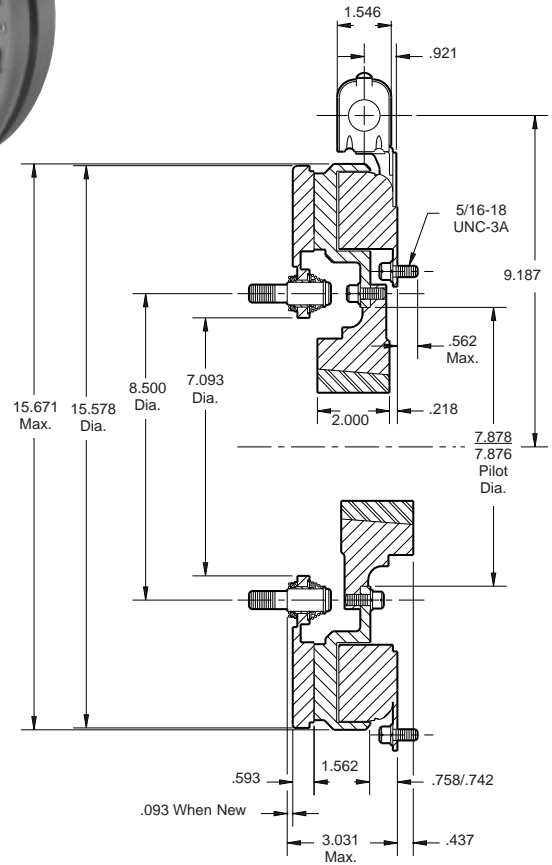

FIELD VIEW

(Inside & Outside Mounted)

Customer Shall Maintain:

1. Concentricity of field mounting pilot diameter with rotor mounting shaft within .006 T.I.R.
2. Squareness of field mounting face with rotor mounting shaft within .006 T.I.R. measured at field mounting bolt circle.
3. Rotor mounting shaft concentric with armature center of rotation within .006 T.I.R.
4. Armature hub pilot diameter to be concentric with armature center of rotation within .010 T.I.R.

When Hub is Furnished by customer:

Rotor mounting pilot diameter must be concentric with rotor mounting shaft within .006 T.I.R.

* Mounting holes are within .010 of true position relative to pilot diameter.
 ** Mounting holes are within .008 of true position relative to pilot diameter.

Shaft Size	.937 – 3.000
Static Torque	700 lb.ft.
Maximum Speed	2,000 rpm
Standard Voltage	D.C. 6, 24, 90

All dimensions are nominal unless otherwise noted.

Information on inertia and weights begins on page 239. Coil data is on pages 250 and 251.



Drawing I-25625

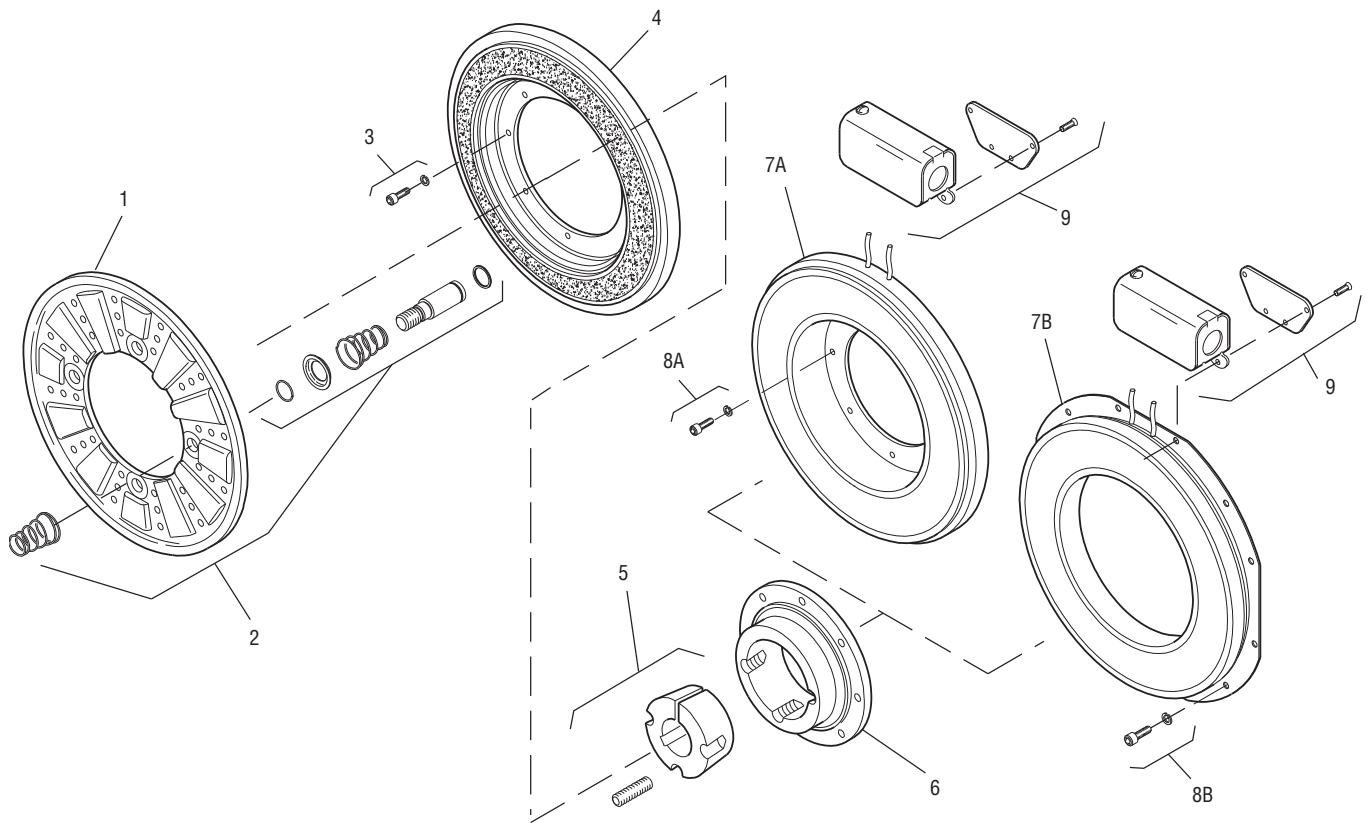

Item	Description	Part Number	Qty.
1	Armature	5304-111-004	1
2	Autogap Accessory	5201-101-008	4
3	Mounting Accessory	5321-101-002	2
4	Rotor		1
	Standard Friction Material	5204-751-002	
	†Optional LK Facing	5204-751-004	
5	Bushing*		1
	15/16" to 3" Bore	180-0223 to 180-0256	
6	Rotor Hub	540-0004	1
7A	Field - Inside Mounted		1
	6 Volt	5204-451-013	
	24 Volt	5204-451-015	
	90 Volt	5204-451-016	
7B	Field - Outside Mounted		1
	6 Volt	5204-451-055	
	24 Volt	5204-451-056	
	90 Volt	5204-451-057	
8A	Mounting Accessory - I.M.	5321-101-001	2

Item	Description	Part Number	Qty.
8B	Mounting Accessory - O.M.	5321-101-001	2
9	Conduit Box	5200-101-012	1

How to Order:

1. Specify Bore Size for Item 5.
2. Specify Voltage for Item 7A or 7B.
3. Specify Inside Mounted for Items 7A and 8A or Outside Mounted for Items 7B and 8B.
4. See Controls Section.

Example:

SF-1525 Clutch per I-25625 - 90 Volt, 2" Bore, Inside Mounted.

These units, when used in conjunction with the correct Warner Electric conduit box, meet the standards of UL508 and are listed under guide card #NMTR, file #59164. These units are CSA certified under file #LR11543.

*See page 252 for specific part numbers.

Refer to Service Manual P-215.

†Optional LK facing available. For more information, see page 232.