

SF-1225 Flange Mounted

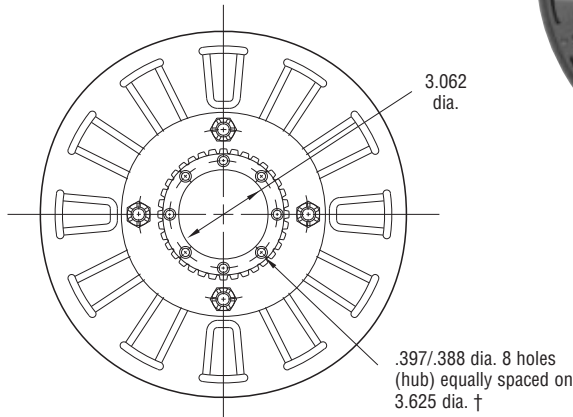

ARMATURE VIEW

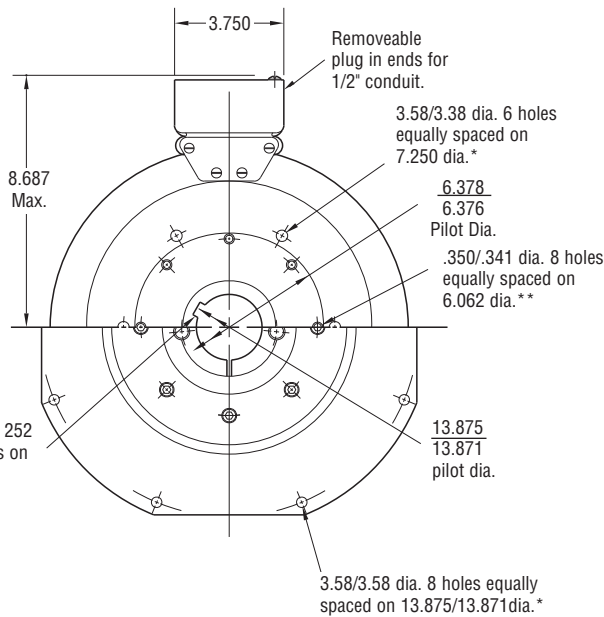

FIELD VIEW

(Inside & Outside Mounted)

Customer Shall Maintain:

1. Concentricity of field mounting pilot diameter with rotor mounting shaft within .006 T.I.R.
2. Squareness of field mounting face with shaft within .006 T.I.R. measured at field mounting bolt circle.
3. Armature hub pilot diameter to be concentric with rotor mounting shaft within .010 T.I.R.

When Hub is Furnished by customer:

Rotor mounting pilot diameter must be concentric with rotor mounting shaft within .006 T.I.R.

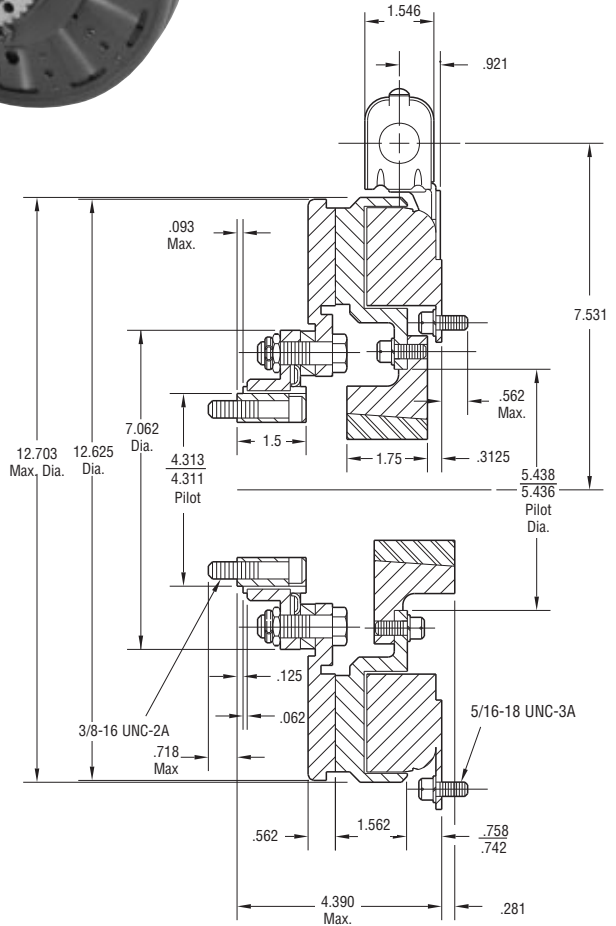

\* Mounting holes are within .010 of true position relative to pilot diameter.

\*\* Mounting holes are within .008 of true position relative to pilot diameter.

† Mounting holes are within .003 of true position relative to pilot diameter.

Shaft Size	.500 – 2.500
Static Torque	465 lb.ft.
Maximum Speed	3,000 rpm
Standard Voltage	D.C. 6, 24, 90

All dimensions are nominal unless otherwise noted.

Information on inertia and weights begins on page 239. Coil data is on pages 250 and 251.

## SF-1225 Flange Mounted

**Drawing I-25601**

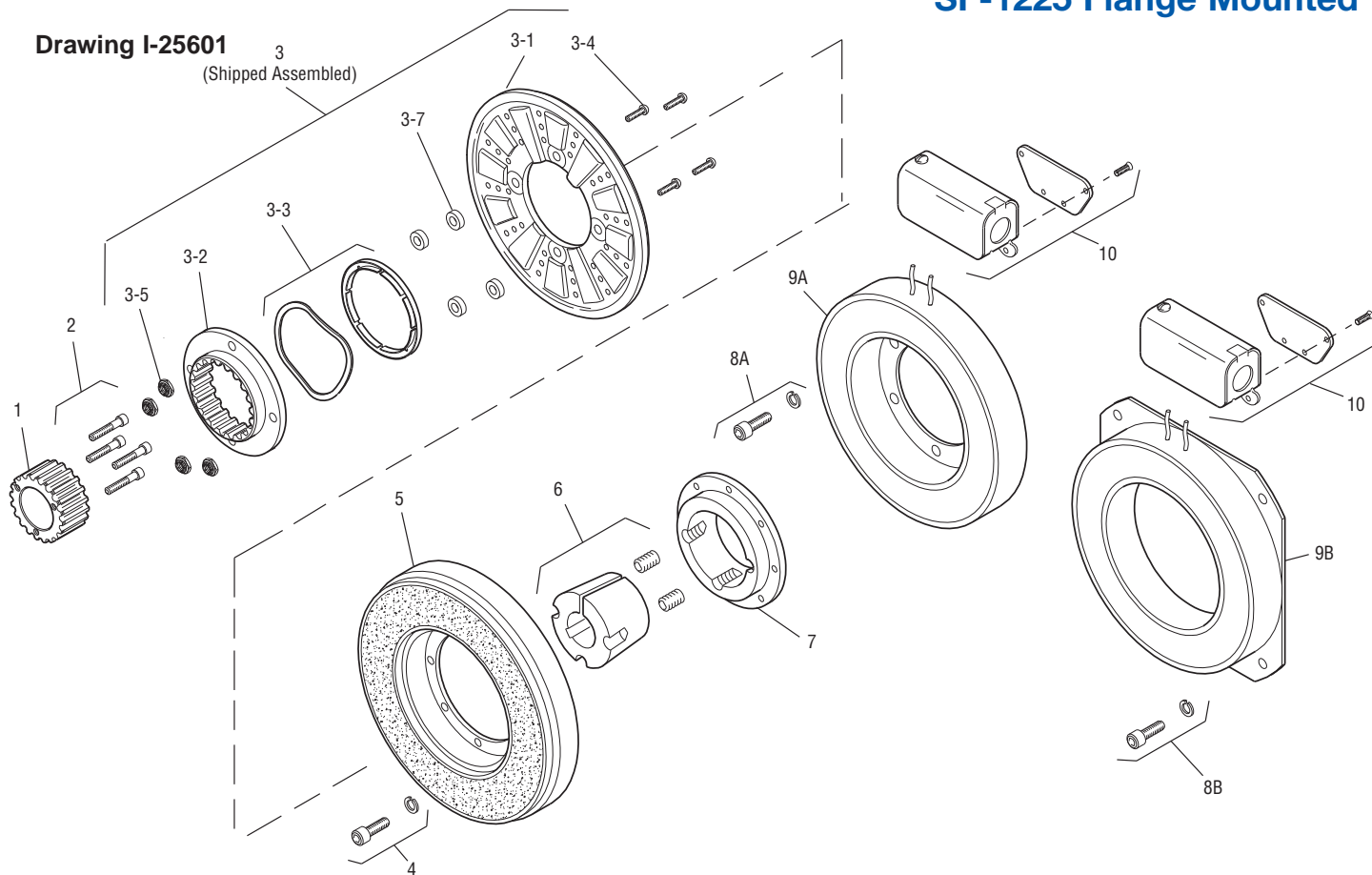

Item	Description	Part Number	Qty.
1	Splined Hub	540-0148	1
2	Mounting Accessory	5202-101-001	1
3	Armature and Splined Adapter	5203-111-001	1
3-1	Armature	5323-111-034	1
3-2	Splined Adapter	104-0010	1
3-3	Autogap Accessory	5323-101-002	1
3-4	Screw	797-0356	4
3-5	Locknut	661-0005	4
3-7	Spacer	266-0004	4
4	Mounting Accessory	5321-101-002	2
5	Rotor		1
	Standard Friction Material	5203-751-001	
	†Optional LK Facing	5203-751-004	
6	Bushing, Taperlock*	180-0185 to 180-0217	1
7	Rotor Hub	540-0318	1
8A	Mounting Accessory, I.M.	5321-101-001	1
8B	Mounting Accessory, O.M.	5321-101-002	2
9A	Field, Inside Mtd.		1
	6 Volt	5203-451-002	
	24 Volt	5203-451-006	
	90 Volt	5203-451-005	

Item	Description	Part Number	Qty.
9B	Field, Outside Mtd.		1
	6 Volts	5203-451-010	
	24 Volts	5203-451-013	
	90 Volts	5203-451-011	
10	Conduit Box	5200-101-012	1

### How to Order:

1. Specify Bore Size for Item 6.
2. Specify Voltage for Item 9A or 9B.
3. Specify Inside Mounted for Items 8A and 9A or Outside Mounted for Items 8B and 9B.
4. See Controls Section.

### Example:

SF-1225 Clutch per I-25601 - 90 Volt, 1-1/2" Bore, Inside Mounted.

These units, when used in conjunction with the correct Warner Electric conduit box, meet the standards of UL508 and are listed under guide card #NMTR, file #59164. These units are CSA certified under file #LR11543.

\*See page 252 for specific part numbers.

Refer to Service Manual P-215.

†Optional LK facing available. For more information, see page 232.