

SF-1000 Flange Mounted

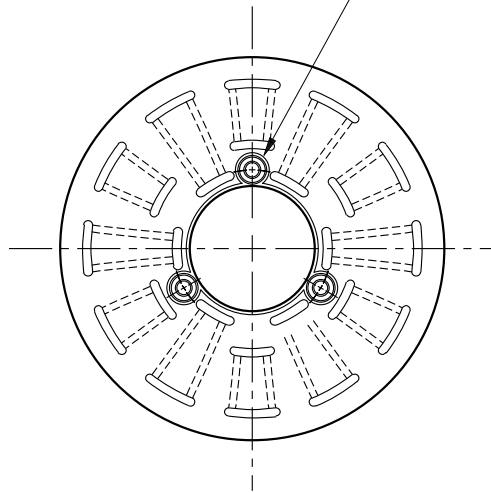

See page 230 for Drive Pin mountings.



ARMATURE VIEW

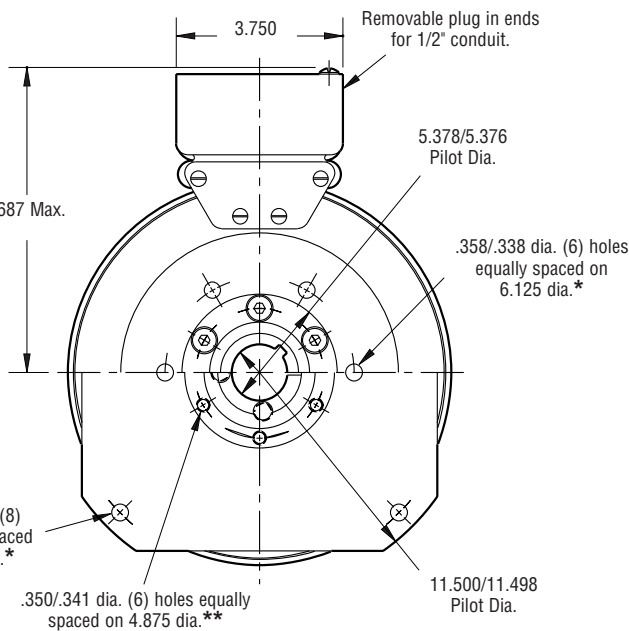

FIELD VIEW

(Inside & Outside Mounted)

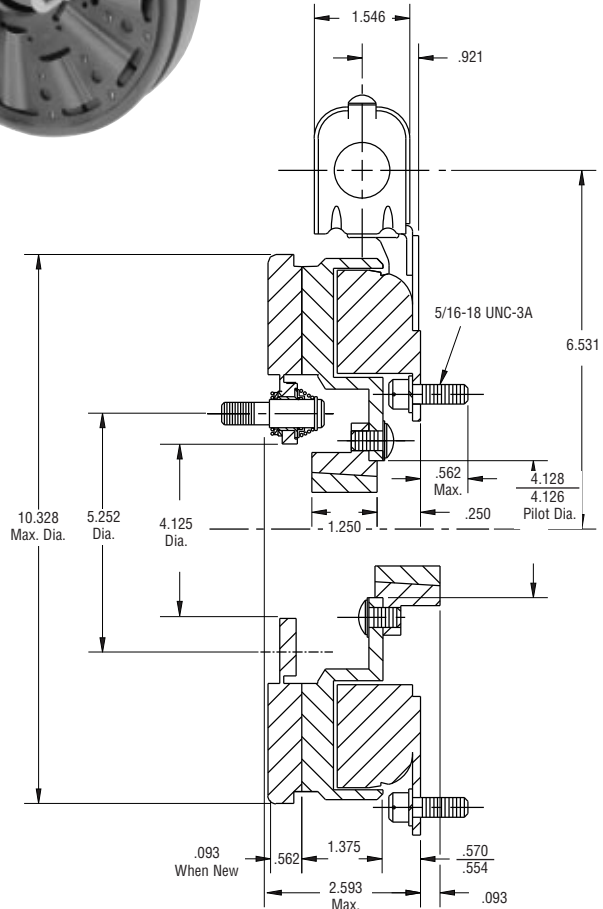

\* Mounting holes are within .010 of true position relative to pilot diameter.

\*\* Mounting holes are within .008 of true position relative to pilot diameter.

Shaft Size	.500 – 2.000
Static Torque	240 lb.ft.
Maximum Speed	3,600 rpm
Standard Voltage	D.C. 6, 24, 90

All dimensions are nominal unless otherwise noted.

Information on inertia and weights begins on page 239. Coil data is on pages 250 and 251.

Customer Shall Maintain:

1. Concentricity of field mounting pilot diameter with rotor mounting shaft within .006 T.I.R.
2. Squareness of field mounting face with shaft within .006 T.I.R. measured at field mounting bolt circle.



Drawing I-25580

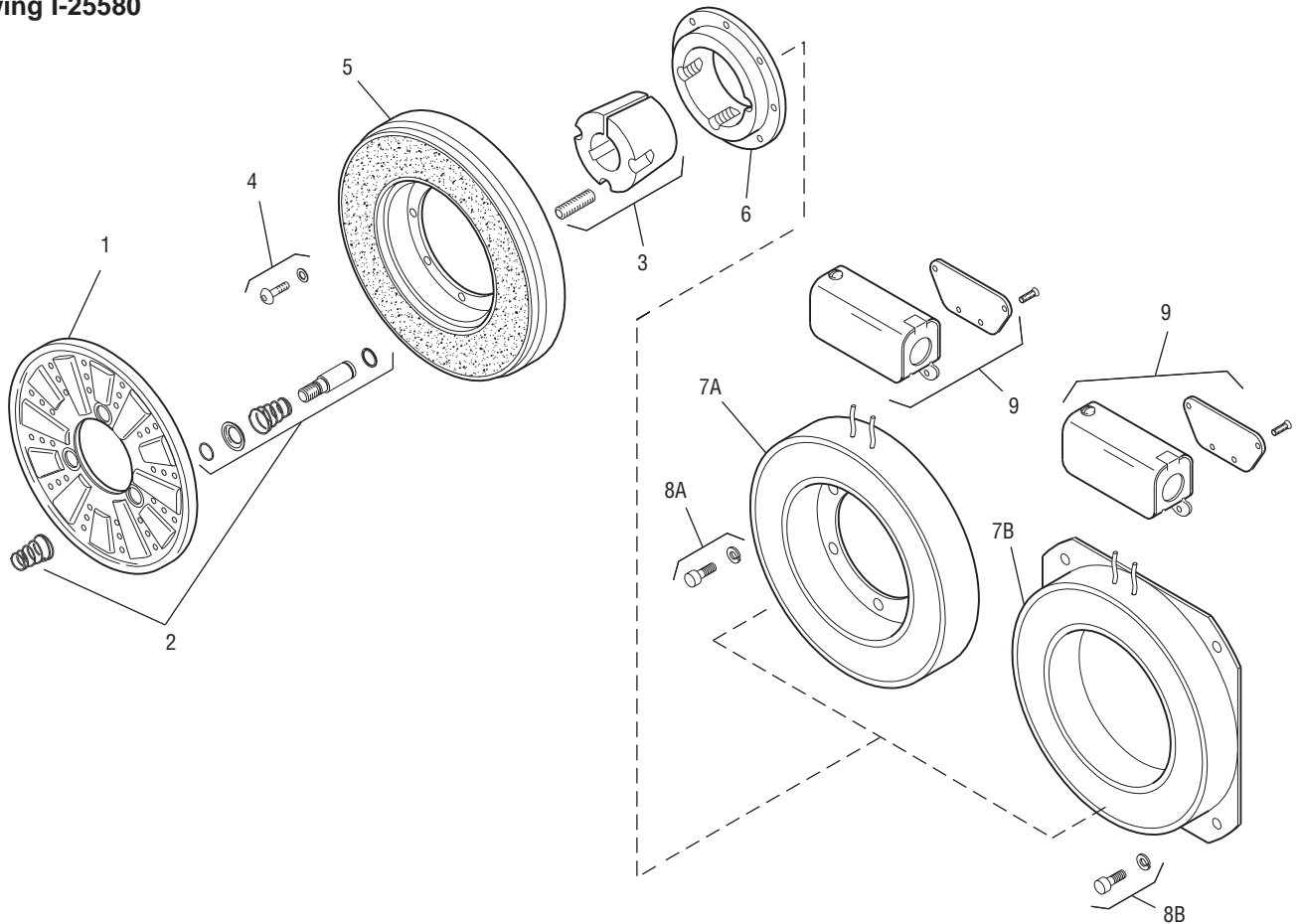

Item	Description	Part Number	Qty.
1	Armature	5302-111-013	1
2	Autogap Accessory	5201-101-008	3
3	Bushing*		1
	1/2" to 2" Bore	180-0155 to 180-0179	
4	Mounting Accessory	5201-101-007	1
5	Rotor		1
	Standard Friction Material	5202-751-003	
	†Optional LK Facing	5202-751-007	
6	Rotor Hub	540-0315	1
7A	Field - Inside Mounted		1
	6 Volt	5202-451-004	
	24 Volt	5202-451-006	
	90 Volt	5202-451-007	
7B	Field - Outside Mounted		1
	6 Volt	5202-451-011	
	24 Volt	5202-451-013	
	90 Volt	5202-451-014	
8A	Mounting Accessory - I.M.	5321-101-001	1
8B	Mounting Accessory - O.M.	5321-101-002	2
9	Conduit Box	5200-101-012	1

**How to Order:**

1. Specify Bore Size for Item 3.
2. Specify Voltage for Items 8A or 8B.
3. Specify Inside Mounted for Items 7A and 8A or Outside Mounted for Items 7B and 8B.
4. See Controls Section.

**Example:**

SF-1000 Clutch per I-25580 -90 Volt, 1" Bore, Inside Mounted

These units, when used in conjunction with the correct Warner Electric conduit box, meet the standards of UL508 and are listed under guide card #NMTR, file #59164.

These units are CSA certified under file #LR11543.

\*See page 252 for specific part numbers.

Refer to Service Manual P-222.

†Optional LK facing available. For more information, see page 232.