

SF-1000 Bearing Mounted

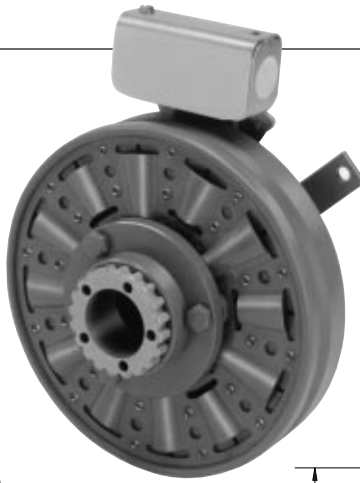

.397/.388 dia. 3 holes (hub) equally spaced on 3.187 dia. and within .003 of true position relation to 4.001/3.999 pilot dia.

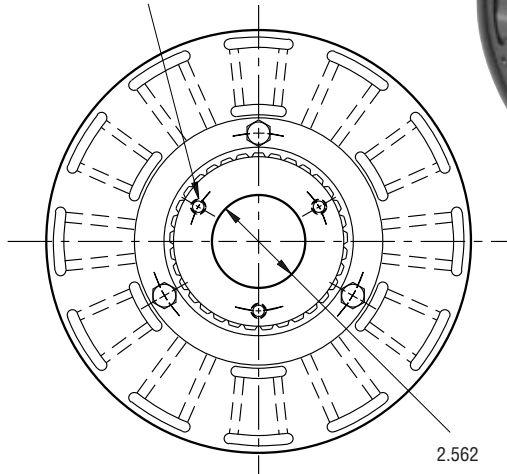

ARMATURE VIEW

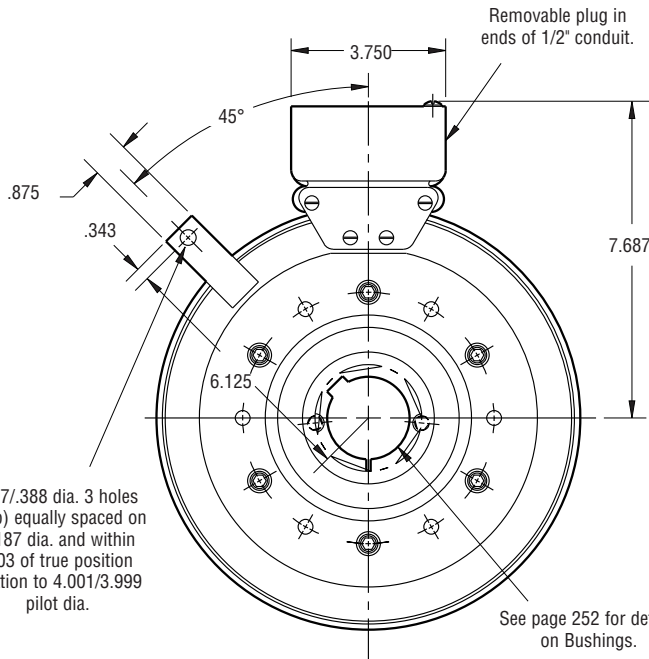
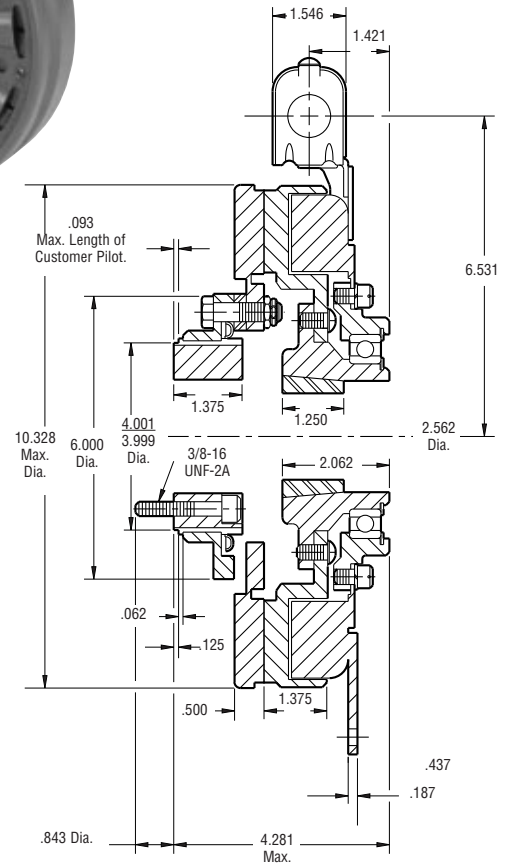

FIELD VIEW

.397/.388 dia. 3 holes (hub) equally spaced on 3.187 dia. and within .003 of true position relation to 4.001/3.999 pilot dia.

See page 252 for details on Bushings.

Shaft Size	.500 – 2.000
Static Torque	240 lb.ft.
Maximum Speed	2,500 rpm
Standard Voltage	D.C. 6, 24, 90

All dimensions are nominal unless otherwise noted.

Information on inertia and weights begins on page 239. Coil data is on pages 250 and 251.

Customer Shall Maintain:

1. Armature hub pilot diameter to be concentric with field and rotor mounting shaft within .010 T.I.R.



Drawing I-25597

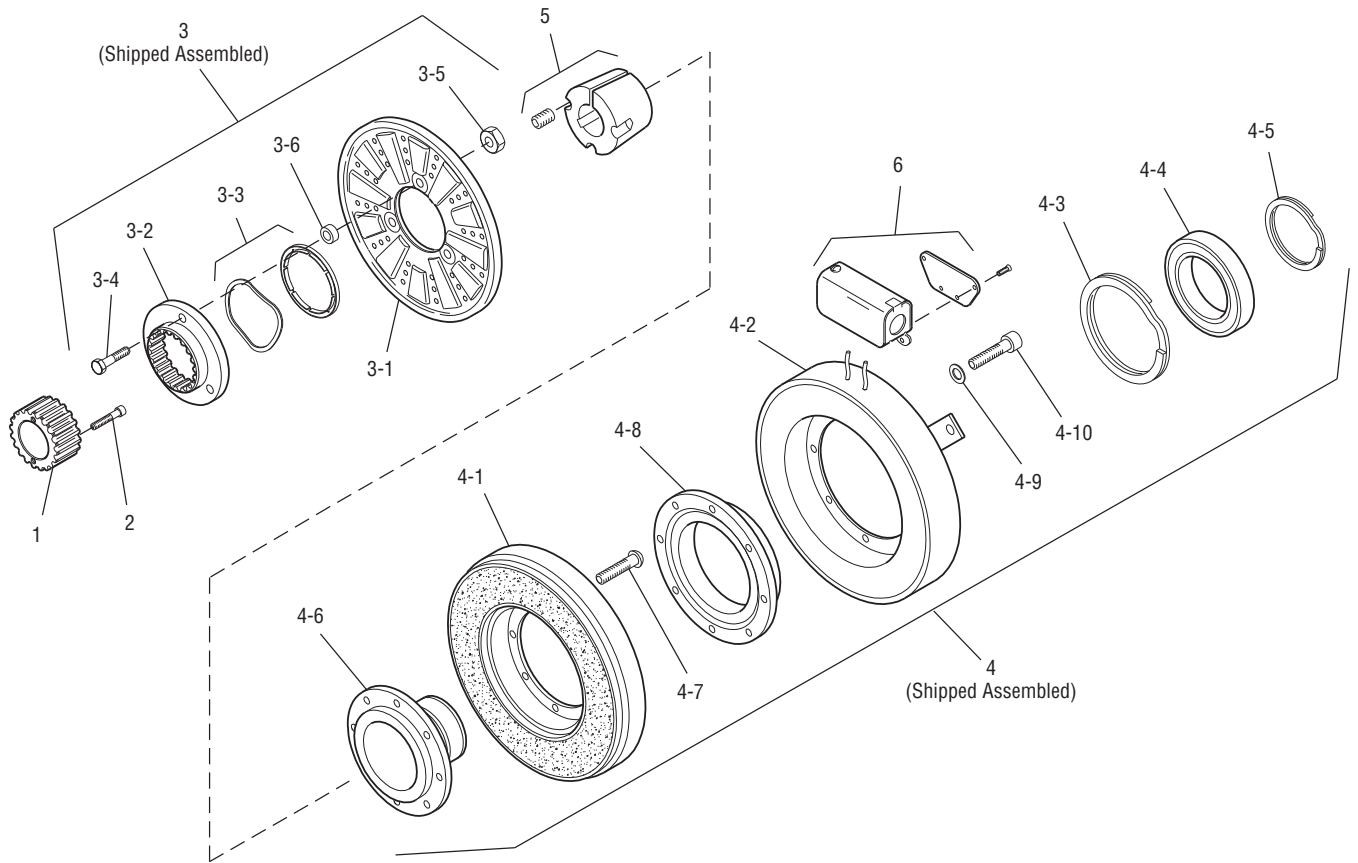

Item	Description	Part Number	Qty.
1	Splined Hub	540-0147	1
2	Accessory, Mounting	5202-101-001	1
3	Armature & Adapter Assembly	5202-111-001	1
3-1	Armature	5322-111-036	1
3-2	Splined Adapter	104-0009	1
3-3	Autogap Accessory	5322-101-004	1
3-4	Screw	797-0341	3
3-5	Locknut	661-0004	3
3-6	Spacer	748-0333	3
4	Field & Rotor Assembly		1
	6 Volt	5202-452-012	
	24 Volt	5202-452-014	
	90 Volt	5202-452-015	
4-1	Rotor		1
	Standard Friction Material	5202-751-003	
	†Optional LK Facing	5202-751-007	
4-2	Field & Bearing Assembly		1
	6 Volt	5202-451-040	
	24 Volt	5202-451-042	
	90 Volt	5202-451-043	
4-3	Retainer Ring	748-0116	1

Item	Description	Part Number	Qty.
4-4	Ball Bearing	166-1046	1
4-5	Retainer Ring	748-0582	1
4-6	Rotor Hub	540-1300	1
4-7	Buttonhead Capscrew	797-1261	6
4-8	Ring Adapter	748-1047	1
4-9	Lockwasher	950-0359	6
4-10	Socket Head Capscrew	797-0422	6
5	Bushing*	180-0155 to 180-0179	1
6	Conduit Box	5200-101-012	1

How to Order:

1. Specify Bore Size for Item 5.
2. Specify Voltage for Item 4.
3. See Controls Section.

Example:

SF-1000 Clutch per I-25597 - 90 Volt, 1" Bore

These units, when used in conjunction with the correct Warner Electric conduit box, meet the standards of UL508 and are listed under guide card #NMTR, file #59164. These units are CSA certified under file #LR11543.

*See page 252 for specific part numbers.

Refer to Service Manual P-215.

†Optional LK facing available. For more information, see page 232.