

Clutch/Brake Coupling

PCBC-500 Normal Duty

1/2-14 NPSM Am. std. straight pipe tap.

See page 252 for details on Bushings.

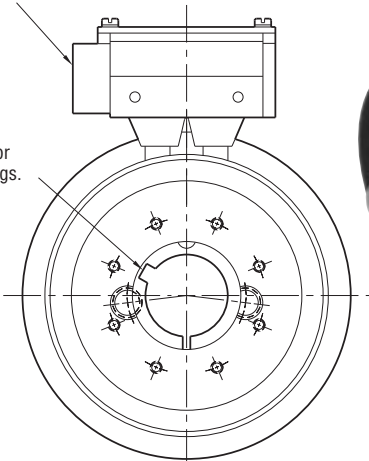

COLLECTOR RING VIEW

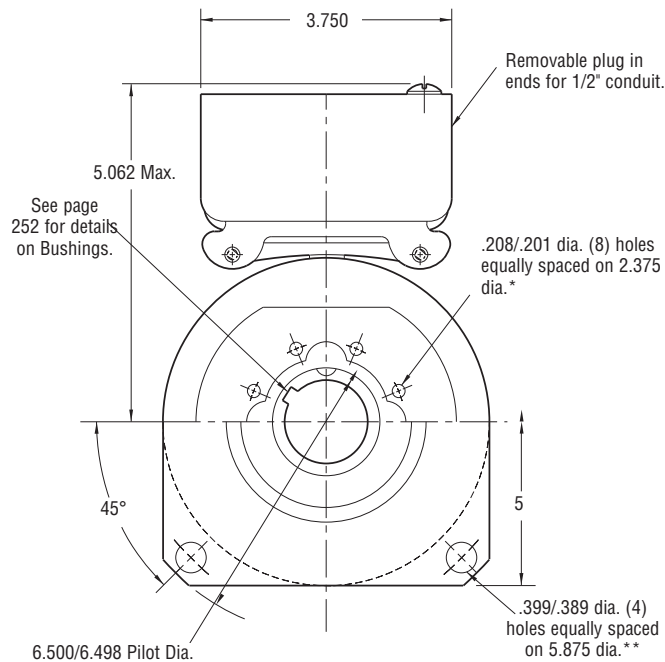
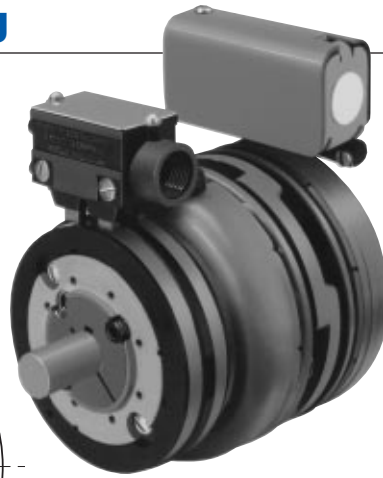

**MAGNET VIEW
(Inside & Outside Mounted)**

* Mounting holes are within .010 of true position relative to pilot diameter.

** Mounting holes are within .008 of true position relative to pilot diameter.

Customer Shall Maintain:

1. Squareness of brake mounting face with armature hub shaft within .006 T.I.R.
2. Concentricity of brake mounting pilot diameter with armature hub shaft within .010 T.I.R.
3. Concentricity of clutch magnet hub assembly shaft with armature hub shaft within .006 T.I.R.

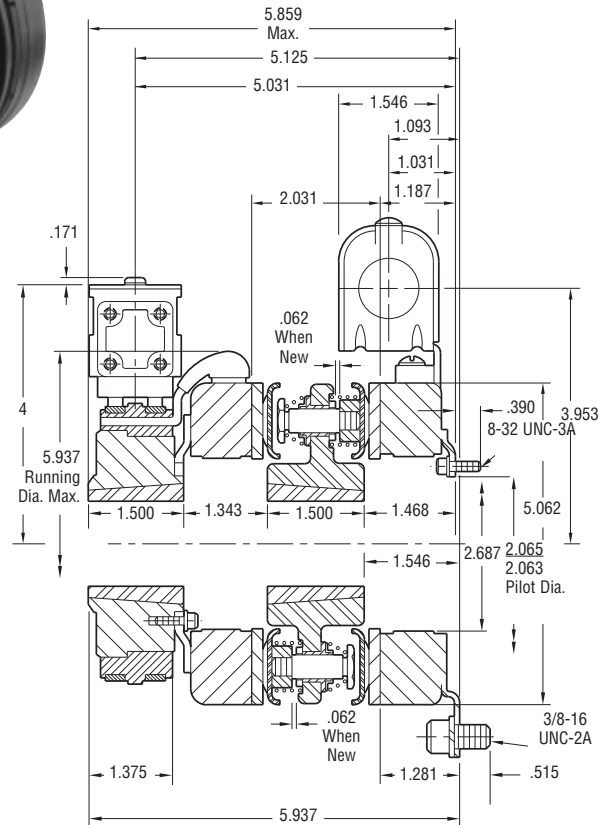

Outside Mounted Offset Backing Plate

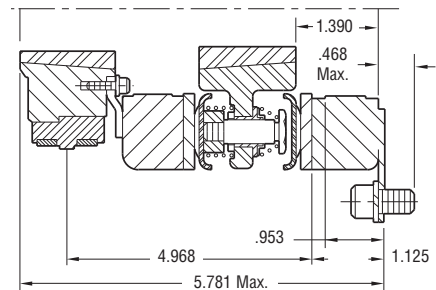

Outside Mounted Flush Backing Plate

Armature Shaft	.500 – 1.250
Magnet Shaft	.500 – 1.250
Static Torque	40 lb. ft.
Maximum Speed	5,400 rpm
Standard Voltage	D.C. 6, 24, 90

All dimensions are nominal unless otherwise noted.

Information on inertia and weights begins on page 239. Coil data is on pages 250 and 251.

Drawing I-25547

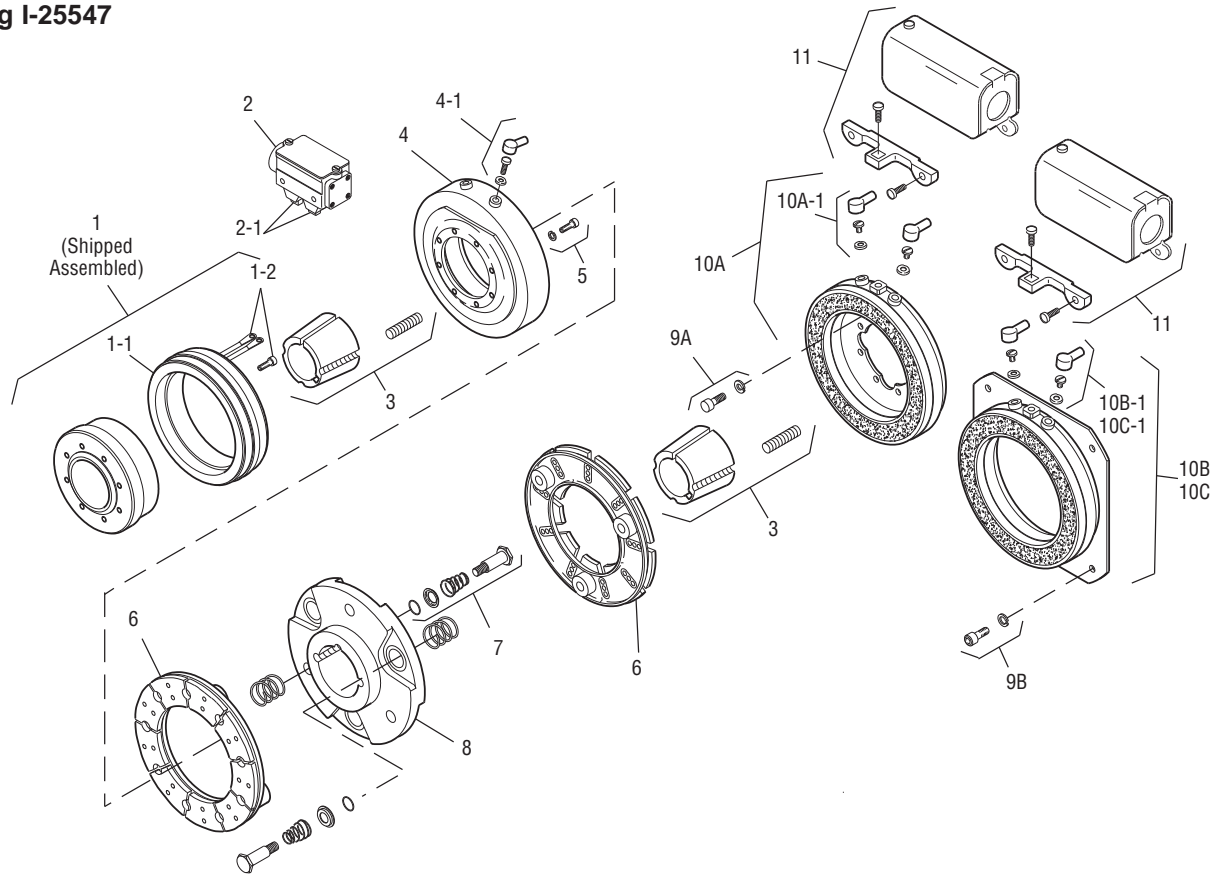

Item	Description	Part Number	Qty.
1	Magnet Hub	5300-541-001	1
1-1	Collector Ring	5300-749-001	1
1-2	Collector Ring Mounting Accessory	5300-101-002	1
2	Brushholder	5300-178-001	1
2-1	Brush	176-0001	4
3	Bushing*		2
	1/2" - 1/4" Bore	180-0116 to 180-0128	
4	Magnet, Clutch		1
	6 Volt	5300-631-002	
	24 Volt	5300-631-003	
	90 Volt	5300-631-005	
4-1	Terminal Accessory	5311-101-001	1
5	Mounting Accessory	5102-101-001	2
6	Armature	5300-111-002	2
7	Autogap Accessory	5200-101-009	6
8	Armature Hub	5300-541-004	1
9A	Mounting Accessory - I.M.	5102-101-001	2
9B	Mounting Accessory - O.M.	5300-101-008	1
10A	Magnet - I.M.		1
	6 Volt	5300-631-002	
	24 Volt	5300-631-003	
	90 Volt	5300-631-005	
10A-1	Terminal Accessory	5311-101-001	1

Item	Description	Part Number	Qty.
10B	Magnet - O.M. - Offset		1
	90 Volt	5300-631-014	
10B-1	Terminal Accessory	5311-101-001	1
10C	Magnet - O.M. - Flush		1
	6 Volt	5300-631-009	
	24 Volt	5300-631-010	
	90 Volt	5300-631-011	
10C-1	Terminal Accessory	5311-101-001	1
11	Conduit Box	5200-101-010	1

How to Order:

1. Specify Bore Size for Item 3 (two shafts).
2. Specify Voltage for Item 4 and Item 10A, 10B or 10C.
3. Specify Inside Mounted for Item 10A and Outside Mounted (Offset) for Item 10B or Outside Mounted (Flush) for Item 10C.
4. See Controls Section.

Example:

PCBC-500 Clutch Brake Coupling per I-25547 - 90 Volt, Inside Mounted, 1" Bore

These units meet the standards of UL508 and are listed under guide card #NMTR2, file #59164. These units are CSA certified under file #LR11543.

*See page 252 for specific part numbers.

Refer to Service Manual P-203.