

Clutch/Brake Coupling

PCBC-1525/1225

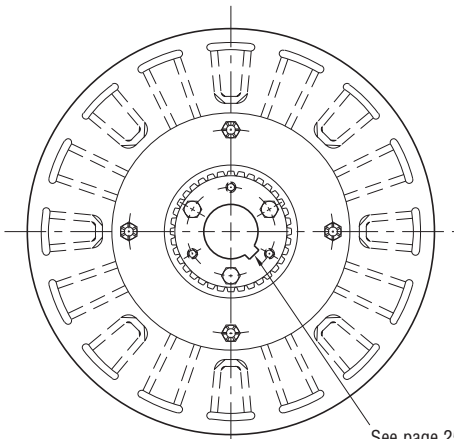
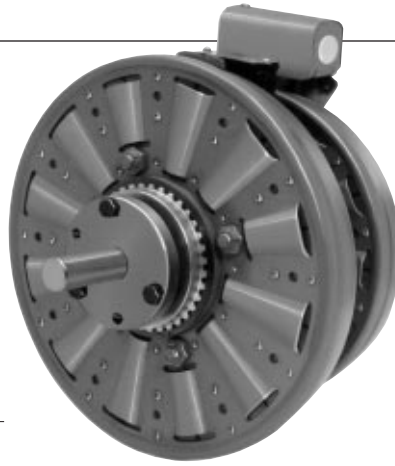

ARMATURE VIEW

See page 252 for details on Bushings.

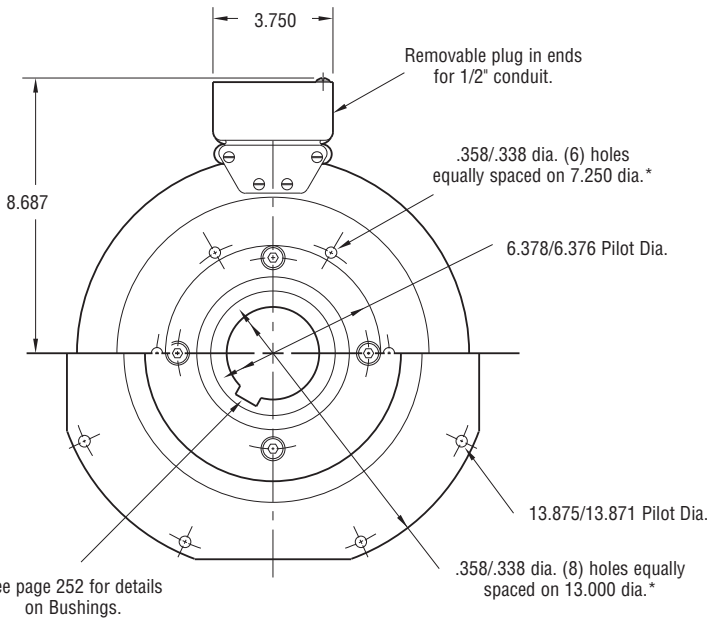

**MAGNET VIEW
(Inside & Outside Mounted)**

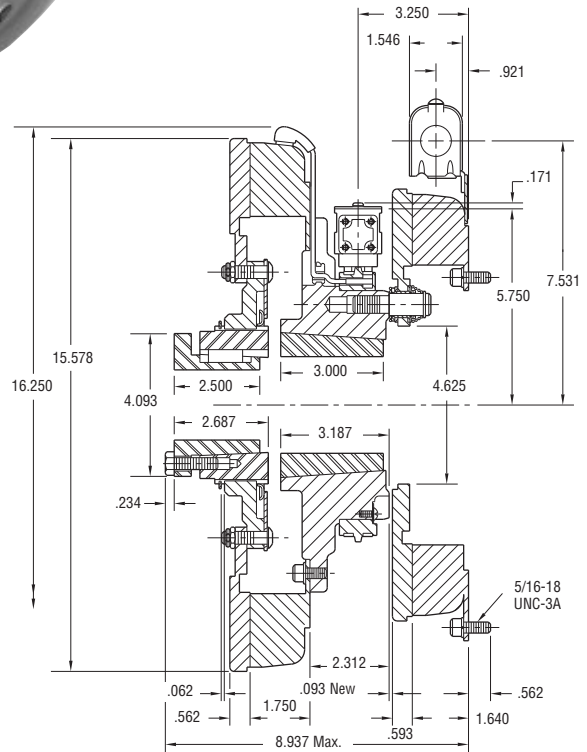

* Mounting holes are within .010 of true position relative to pilot diameter.

Customer Shall Maintain:

1. Armature mounting shaft concentric with magnet mounting shaft within .006 T.I.R.
2. Squareness of brake magnet mounting face with magnet mounting shaft within .006 T.I.R.
3. Concentricity of brake magnet mounting pilot diameter with magnet mounting shaft within .010 T.I.R.

Armature Shaft	.750 – 2.687
Magnet Shaft	.937 – 3.000
Static Torque Clutch	700 lb.ft.
Static Torque Brake	465 lb.ft.
Maximum Speed	2,000 rpm
Standard Voltage	D.C. 6, 24, 90

All dimensions are nominal unless otherwise noted.

Information on inertia and weights begins on page 239. Coil data is on pages 250 and 251.



Drawing I-25637

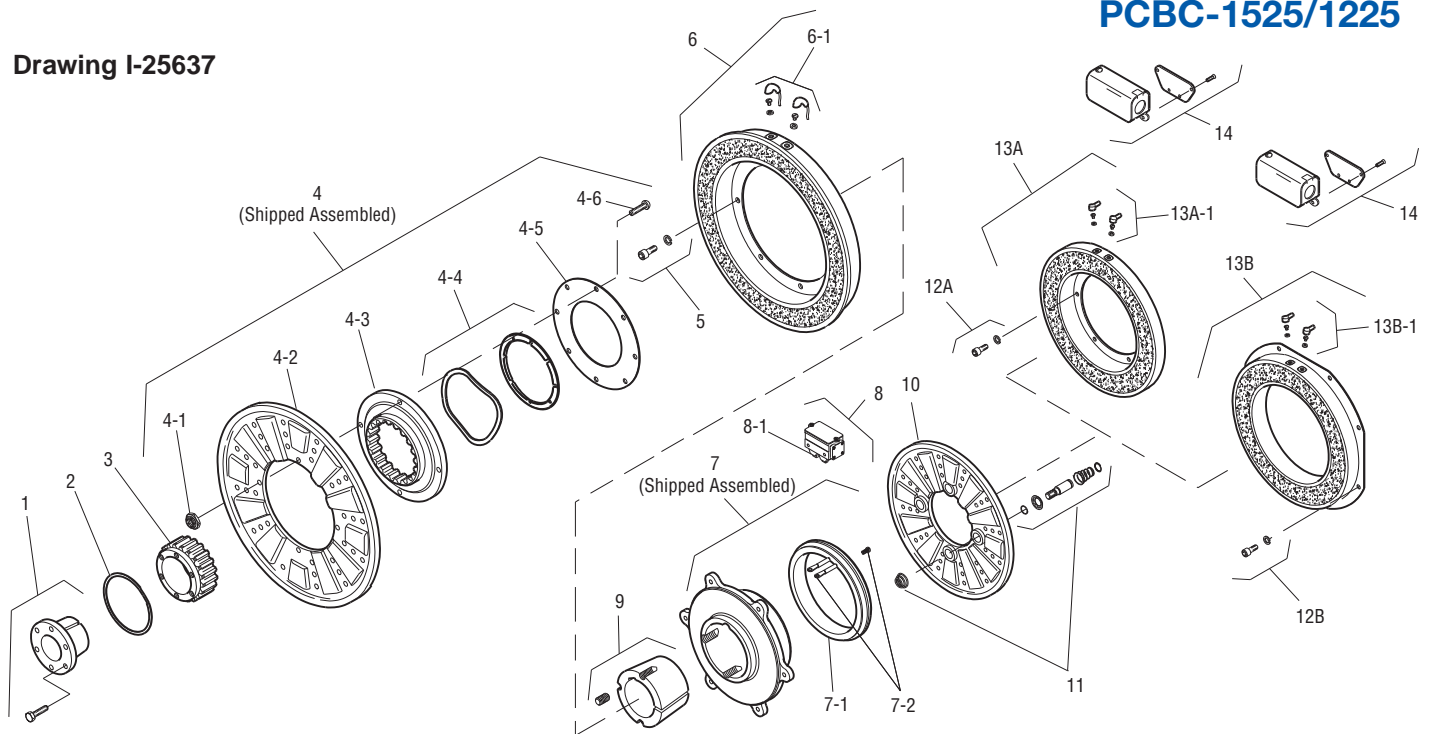

Item	Description	Part Number	Qty.
1	Bushing*		1
	3/4" to 2-11/16" Bore	180-0026 to 180-0057	
2	Retainer Ring	748-0005	1
3	Splined Hub	540-0064	1
4	Armature & Splined Adapter	5324-111-001	1
4-1	Locknut	661-0004	8
4-2	Armature	5324-111-034	1
4-3	Splined Adapter	104-0011	1
4-4	Autogap Accessory	5323-101-002	1
4-5	Retainer Plate	686-0003	1
4-6	Screw	797-0272	8
5	Mounting Accessory	5321-101-001	2
6	Magnet		1
	6 Volt	5304-631-009	
	24 Volt	5304-631-011	
	90 Volt	5304-631-010	
6-1	Terminal Accessory	5311-101-001	1
7	Magnet Hub		1
	Left Hand (shown)	5304-541-001	
	Right Hand	5304-541-002	
7-1	Collector Ring	5301-749-001	1
7-2	Collector Ring Accessory	5304-101-004	1
8	Brushholder	5300-178-001	1
8-1	Brush	176-0001	4
9	Bushing*		1
	15/16" to 3" Bore	180-0262 to 180-0295	
10	Armature	5303-111-009	1
11	Autogap Accessory	5201-101-008	4
12A	Mounting Accessory - I.M.	5321-101-001	1

Item	Description	Part Number	Qty.
12B	Mounting Accessory - O.M.	5321-101-002	2
13A	Magnet - Inside Mounted		1
	6 Volt	5313-631-005	
	24 Volt	5313-631-006	
	90 Volt	5313-631-007	
13A-1	Terminal Accessory	5311-101-001	1
13B	Magnet - Outside Mounted		1
	6 Volt	5313-631-010	
	24 Volt	5313-631-012	
	90 Volt	5313-631-011	
13B-1	Terminal Accessory	5311-101-001	1
14	Conduit Box	5200-101-010	1

How to Order:

1. Specify Bore Size for Items 1 and 9.
2. Specify Voltage for Item 6 and 13A or 13B.
3. Specify left hand or right hand hub for Item 7. Bushing enters from magnet side for L.H. hub and from hub side for R.H.
4. Specify Inside Mounted for Items 12A and 13A or Outside Mounted for Items 12B and 13B.
5. See Controls Section.

Example:

PCBC-1525/1225 Clutch Brake Coupling per I-25637 - 90 Volt, Inside Mounted, Left Hand hub, 2" Bore (Items 1 and 9)

These units meet the standards of UL508 and are listed under guide card #NMTR2, file #59164. These units are CSA certified under file #LR11543.

*See page 252 for specific part numbers.

Refer to Service Manual P-214.