

Clutch/Brake

PCB-1525/1225 Heavy Duty

(.397/.388) dia. (8) holes (hub) equally spaced on (3.625) dia. and within .003 of true position relative to (4.313/4.311) pilot diameter.

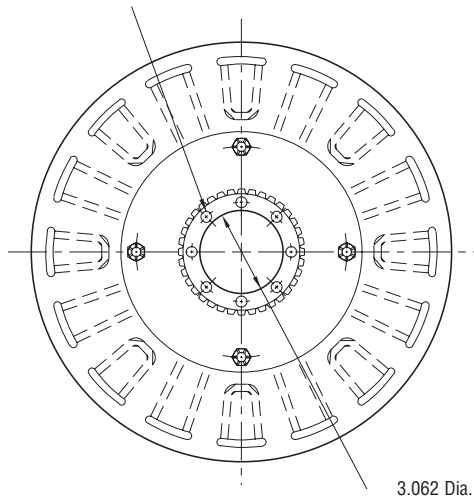

ARMATURE VIEW

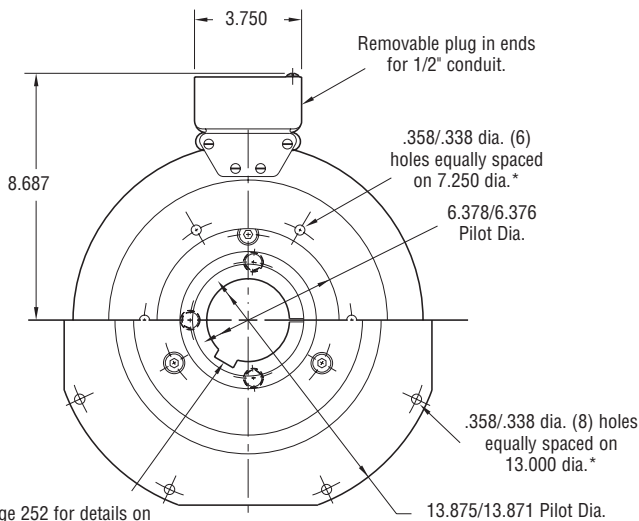

See page 252 for details on Bushings.

MAGNET VIEW

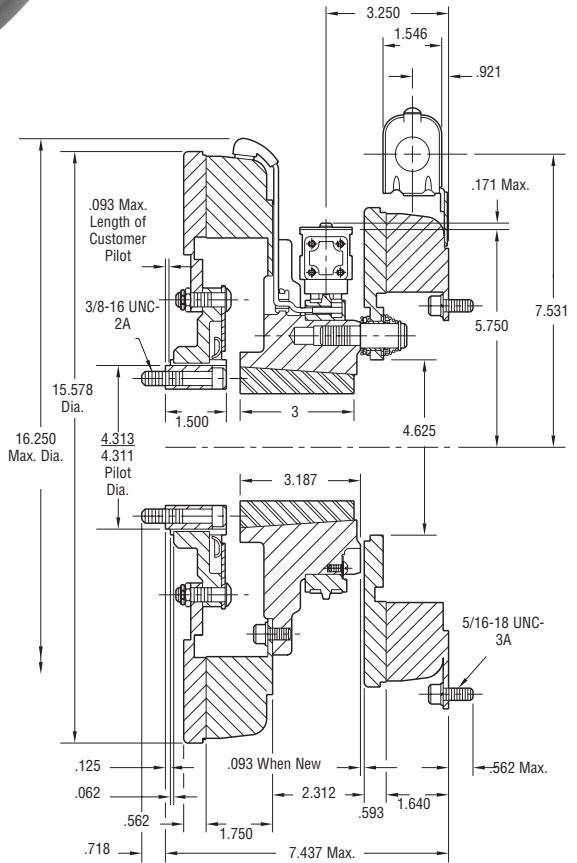

* Mounting holes are within .010 of true position relative to pilot diameter.

Customer Shall Maintain:

1. Concentricity of brake magnet mounting pilot diameter to mounting shaft within .010 T.I.R.
2. Squareness of brake magnet mounting face to magnet mounting shaft within .006 T.I.R.
3. Splined hub pilot diameter to be concentric with splined armature center of rotation within .010 T.I.R.

Shaft Size	.937 – 3.000
Static Torque Clutch	700 lb. ft.
Static Torque Brake	465 lb. ft.
Maximum Speed	2,000 rpm
Standard Voltage	D.C. 6, 24, 90

All dimensions are nominal unless otherwise noted.

Information on inertia and weights begins on page 239. Coil data is on pages 250 and 251.



Drawing I-25636

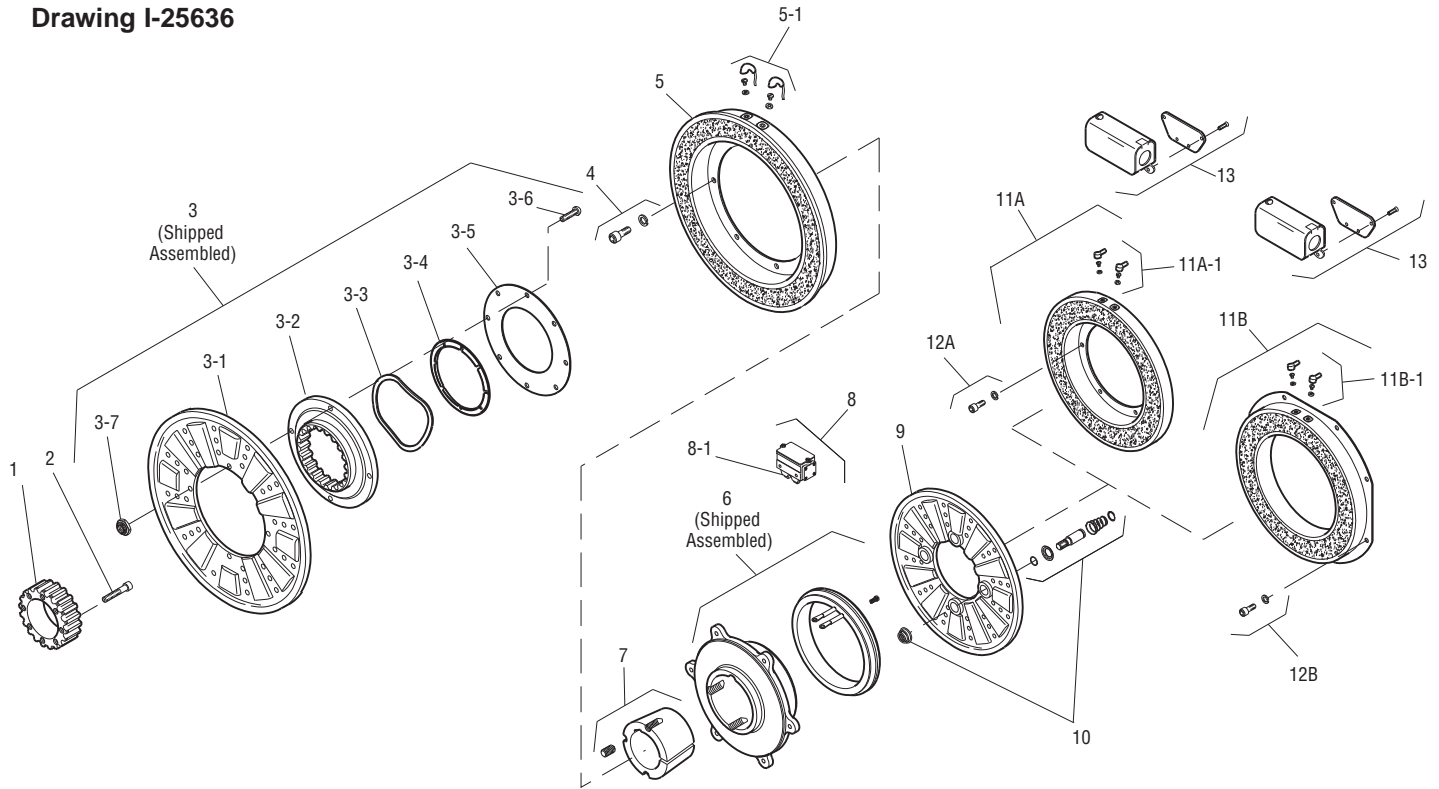

Item	Description	Part Number	Qty.
1	Splined Hub	540-0148	1
2	Mounting Accessory	5202-101-001	1
3	Armature Assembly	5324-111-001	1
3-1	Armature	5324-111-034	1
3-2	Splined Armature Adapter	104-0011	1
3-3	Autogap Spring	808-0044	1
3-4	Retainer Ring	748-0370	1
3-5	Retainer Plate	686-0003	1
3-6	Buttonhead Screw	797-0272	8
3-7	Locknut	661-0004	8
4	Mounting Accessory	5321-101-001	1
5	Magnet Assembly		
	6 Volt	5304-631-009	
	24 Volt	5304-631-011	
	90 Volt	5304-631-010	
5-1	Terminal Accessory	5311-101-001	1
6	Hub Assembly		
	Left Hand (shown)	5304-541-001	
	Right Hand	5304-541-002	
7	Bushing*	180-0262 to 180-0295	1
8	Brushholder	5300-178-001	1
8-1	Brush	176-0001	4
9	Armature Assembly	5303-111-009	1
10	Autogap Accessory	5201-101-008	4
11A	Magnet - Inside Mounted		1
	6 Volt	5313-631-005	
	24 Volt	5313-631-006	
	90 Volt	5313-631-007	

Item	Description	Part Number	Qty.
11A-1	Terminal Accessory	5311-101-001	1
11B	Magnet - Outside Mounted		1
	6 Volt	5313-631-010	
	24 Volt	5313-631-012	
	90 Volt	5313-631-011	
11B-1	Terminal Accessory	5311-101-001	1
12A	Mounting Accessory I.M.	5321-101-001	1
12B	Mounting Accessory O.M.	5321-101-002	2
13	Conduit Box	5200-101-011	1

How to Order:

1. Specify Voltage for Item 5 and Item 11A or 11B.
2. Specify left hand or right hand hub for Item 6. Bushing enters from magnet side for L.H. hub and from hub side for R.H.
3. Specify Bore Size for Item 7.
4. Specify Inside Mounted for Items 11A and 12A or Outside Mounted for Items 11B and 12B.
5. See Controls Section.

Example:

PCB-1525/1225 Clutch Brake per I-25636 - 90 Volt, Left Hand hub, 2" Bore, Inside Mounted

These units meet standards set forth in UL508 and are listed under guide card #NMTR2, file #59164.

These units are CSA certified under file #LR11543.

*See page 252 for specific part numbers.

Refer to Service Manual P-214.