

Clutch/Brake

PCB-1225 Heavy Duty

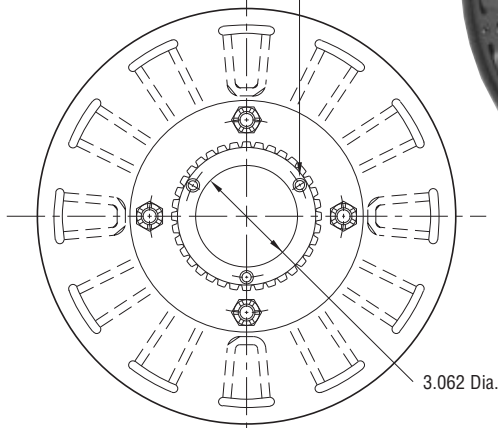

(.397/.388) dia. (8) holes (hub) equally spaced on (3.625) dia. and within .003 of true position in relation to (4.313/4.311) pilot dia.



ARMATURE VIEW

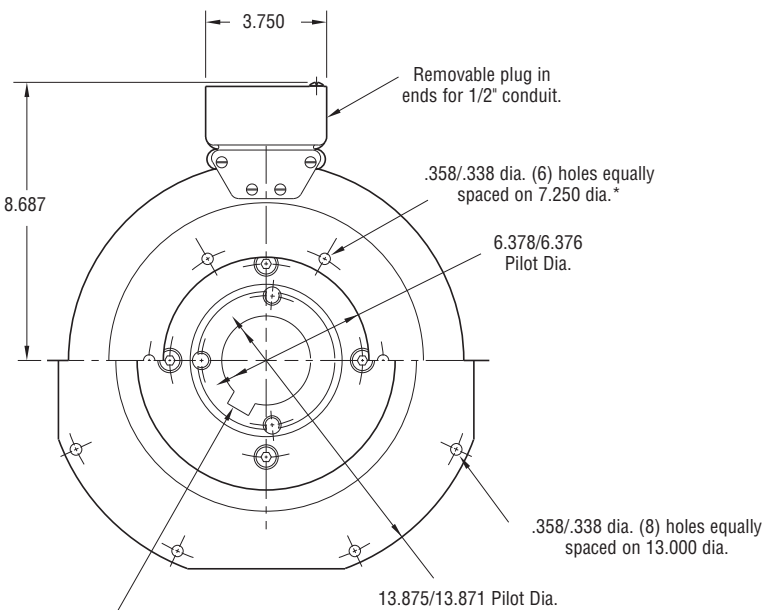

See page 252 for details on Bushings.

MAGNET VIEW
(Inside & Outside Mounted)

Customer Shall Maintain:

1. Concentricity of brake magnet mounting pilot diameter with mounting shaft within .010 T.I.R.
2. Squareness of brake magnet mounting face with magnet mounting shaft within .006 T.I.R.
3. Splined hub pilot diameter to be concentric with splined armature center of rotation within .010 T.I.R.

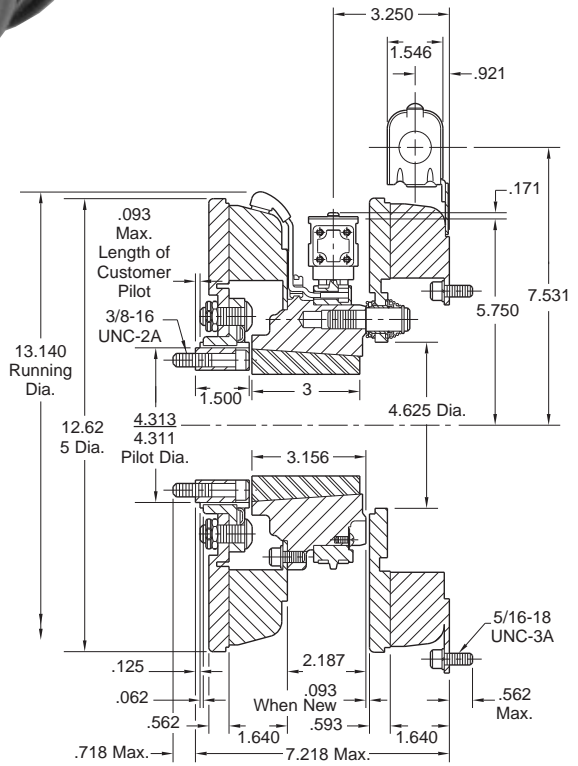

* Mounting holes are within .010 of true position relative to pilot diameter.

Shaft Size	.937 – 3.000
Static Torque	465 lb. ft.
Maximum Speed	3,000 rpm
Standard Voltage	D.C. 6, 24, 90

All dimensions are nominal unless otherwise noted.

Information on inertia and weights begins on page 239. Coil data is on pages 250 and 251.



Drawing I-25609

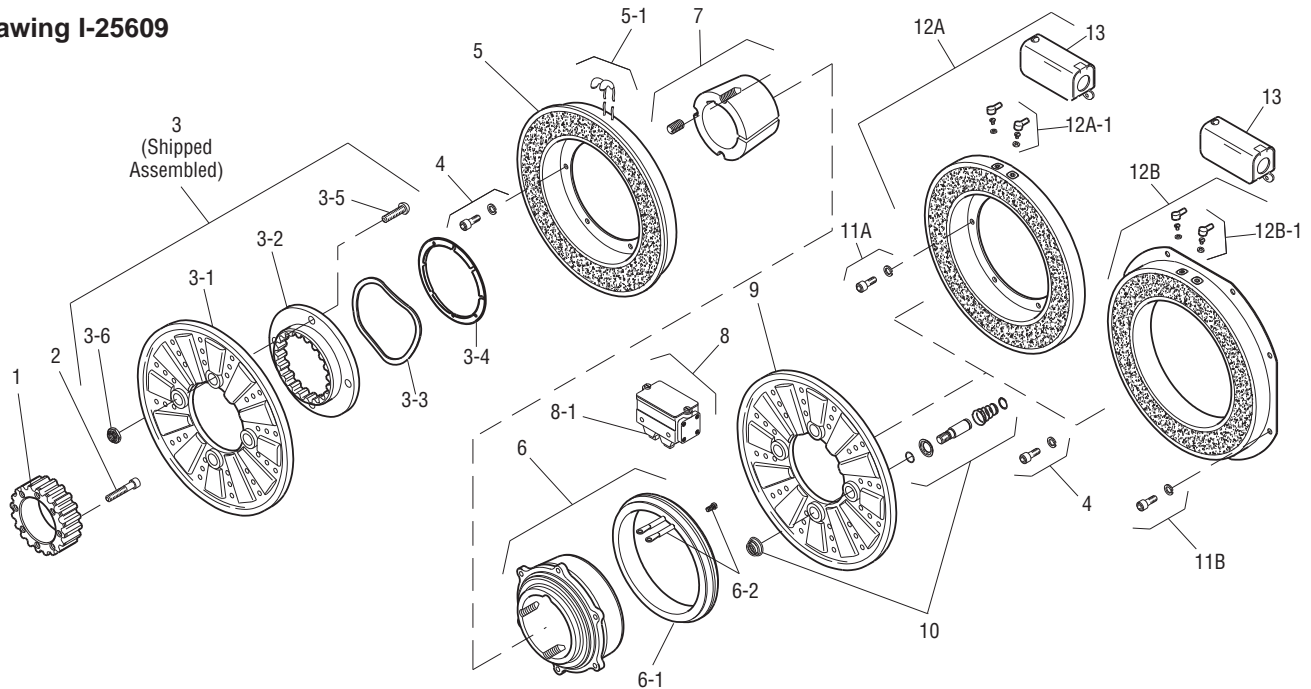

Item	Description	Part Number	Qty.
1	Splined Hub	540-0148	1
2	Mounting Accessory	5202-101-001	1
3	Armature Assembly	5323-111-001	1
3-1	Armature	5323-111-034	1
3-2	Armature Adapter	104-0010	1
3-3	Autogap Spring	808-0044	1
3-4	Retainer Ring	748-0370	1
3-5	Buttonhead Screw	797-0281	3
3-6	Locknut	661-0005	3
4	Mounting Accessory	5321-101-001	1
5	Magnet		1
	6 Volt	5303-631-005	
	24 Volt	5303-631-007	
	90 Volt	5303-631-008	
5-1	Terminal Accessory	5311-101-001	1
6	Magnet Hub		1
	Right Hand	5303-541-002	
	Left Hand (shown)	5303-541-001	
6-1	Collector Ring	5301-749-001	1
6-2	Collector Ring Accessory	5303-101-004	1
7	Bushing*	180-0262 to 180-0295	1
8	Brushholder	5300-178-001	1
8-1	Brush	176-0001	4
9	Armature	5303-111-009	1
10	Autogap Accessory	5201-101-008	4
11A	Mounting Accessory		
	Inside Mounted	5321-101-001	1
11B	Mounting Accessory		
	Outside Mounted	5321-101-002	2

Item	Description	Part Number	Qty.
12A	Magnet - Inside Mounted		1
	6 Volt	5313-631-005	
	24 Volt	5313-631-006	
	90 Volt	5313-631-007	
12A-1	Terminal Accessory	5311-101-001	1
12B	Magnet - Outside Mounted		1
	6 Volt	5313-631-010	
	24 Volt	5313-631-012	
	90 Volt	5313-631-011	
12B-1	Terminal Accessory	5311-101-001	1
13	Conduit Box	5200-101-010	1

How to Order:

1. Specify Voltage for Item 5 and Item 12A or 12B.
2. Specify left hand or right hand hub for Item 6. Bushing enters from magnet side for L.H. hub and from hub side for R.H.
3. Specify Bore Size for Item 7.
4. Specify Inside Mounted for Items 11A and 12A or Outside Mounted for Items 11B and 12B.
5. See Controls Section.

Example:

PCB-1225 Clutch Brake per I-25609 - 90 Volt, Left Hand hub, 2" Bore, Inside Mounted

These units meet the standards of UL508 and are listed under guide card #NMTR2, file #59164. These units are CSA certified under file #LR11543.

*See page 252 for specific part numbers.

Refer to Service Manual P-205.