

# Clutch/Brake

## PCB-1225 Normal Duty

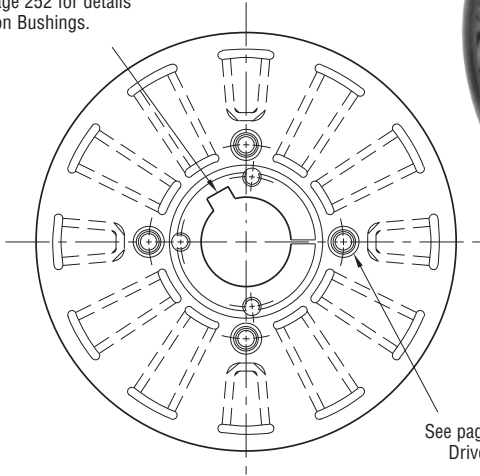

See page 252 for details on Bushings.



**ARMATURE VIEW**

See page 230 for details on Drive Pin mountings.

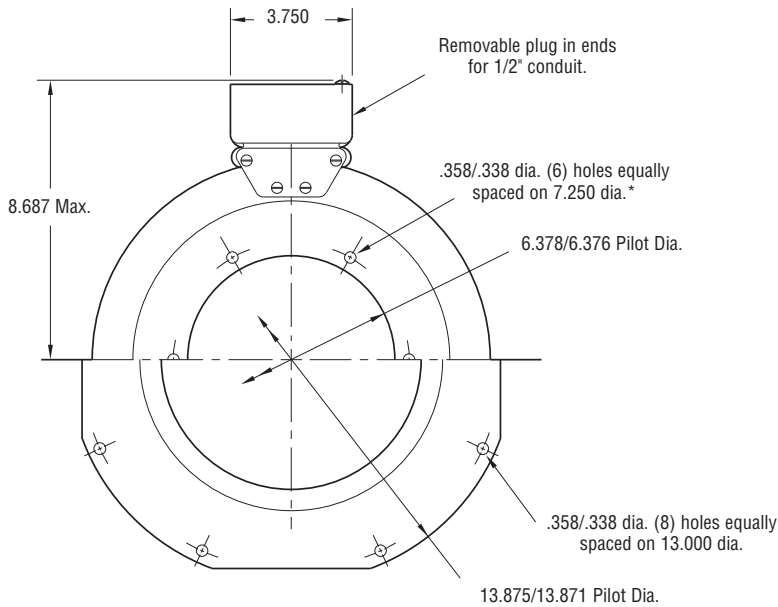

**MAGNET VIEW**  
(Inside & Outside Mounted)

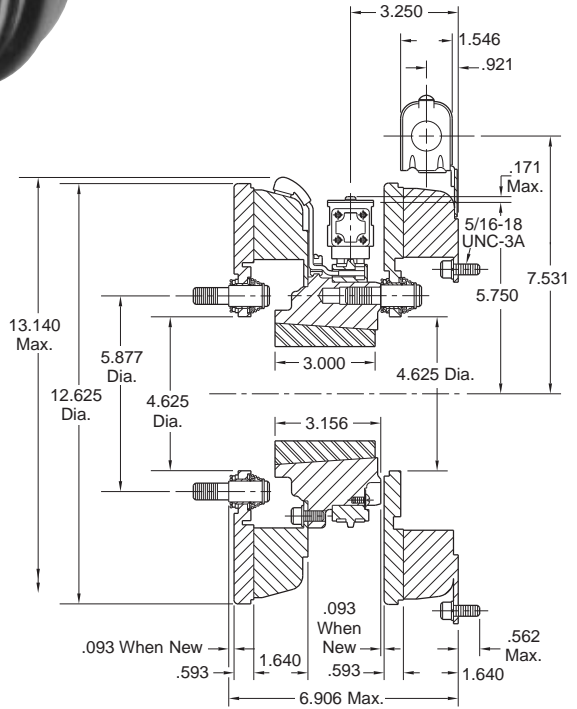

\* Mounting holes are within .010 of true position relative to pilot diameter.

Shaft Size	.937 – 3.000
Static Torque	465 lb. ft.
Maximum Speed	3,000 rpm
Standard Voltage	D.C. 6, 24, 90

All dimensions are nominal unless otherwise noted.

Information on inertia and weights begins on page 239. Coil data is on pages 250 and 251.

### Customer Shall Maintain:

1. Concentricity of brake mounting pilot diameter with mounting shaft within .010 T.I.R.
2. Squareness of brake magnet mounting face with mounting shaft within .006 T.I.R measured at magnet mounting bolt circle.



Drawing I-25608

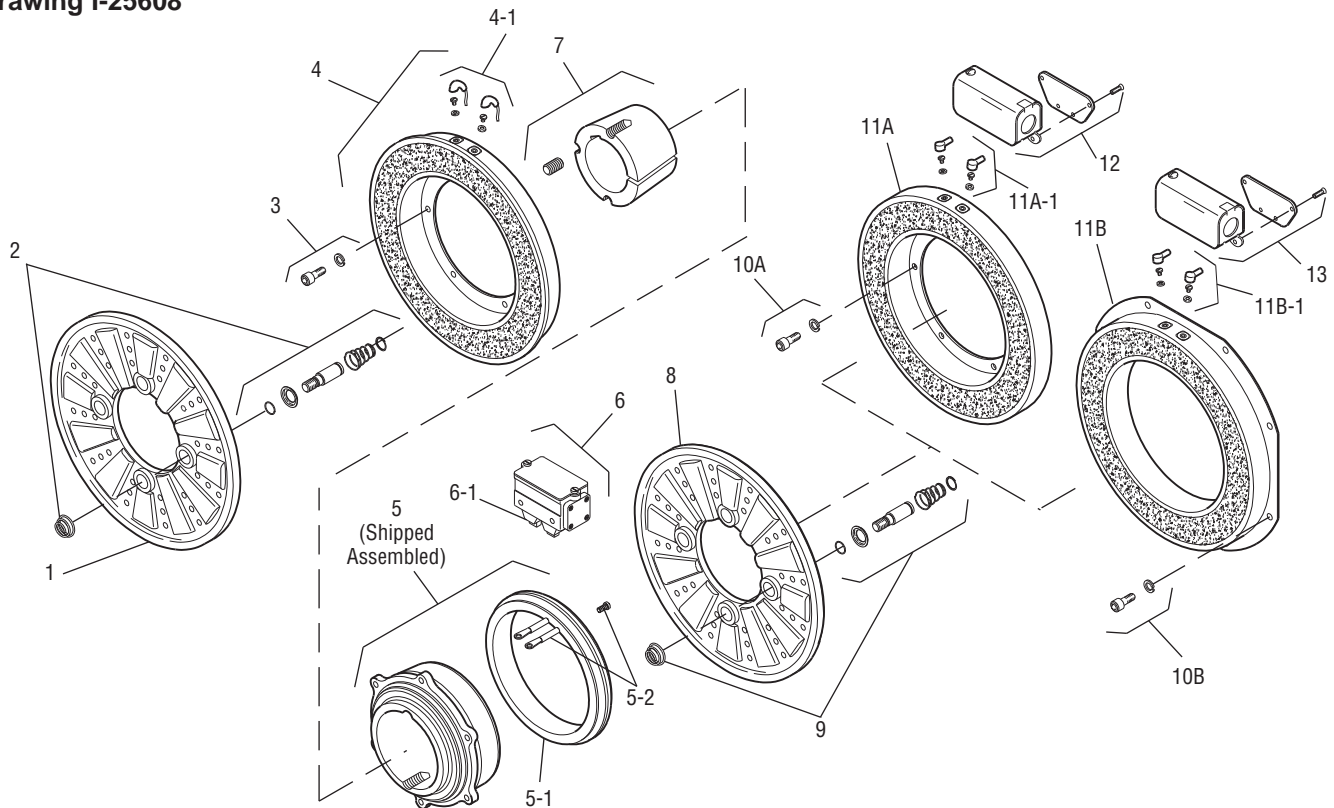

Item	Description	Part Number	Qty.
1	Armature	5303-111-009	1
2	Autogap Accessory	5201-101-008	4
3	Mounting Accessory	5321-101-001	1
4	Magnet		1
	6 Volt	5303-631-005	
	24 Volt	5303-631-007	
	90 Volt	5303-631-008	
4-1	Terminal Accessory	5311-101-001	1
5	Magnet Hub		1
	Left Hand (shown)	5303-541-001	
	Right Hand	5303-541-002	
5-1	Collector Ring	5301-749-001	1
5-2	Collector Ring Assembly	5303-101-004	1
6	Brushholder	5300-178-001	1
6-1	Brush	176-0001	4
7	Bushing*		1
	15/16" to 3" Bore	180-0262 to 180-0295	
8	Armature	5303-111-009	1
9	Autogap Accessory	5201-101-008	4
10A	Mounting Accessory - I.M.	5321-101-001	1
10B	Mounting Accessory - O.M.	5321-101-002	2
11A	Magnet - Inside Mounted		1
	6 Volt	5313-631-005	
	24 Volt	5313-631-006	
	90 Volt	5313-631-007	

Item	Description	Part Number	Qty.
11A-1	Terminal Accessory	5311-101-001	1
11B	Magnet - Outside Mounted		1
	6 Volt	5313-631-010	
	24 Volt	5313-631-012	
	90 Volt	5313-631-011	
11B-1	Terminal Accessory	5311-101-001	1
12	Conduit Box	5200-101-011	2

### How to Order:

1. Specify Voltage for Item 4 and Item 11A or 11B.
2. Specify left hand or right hand hub for Item 5. Bushing enters from magnet side for L.H. hub and from hub side for R.H.
3. Specify Bore Size for Item 7.
4. Specify Inside Mounted for Items 10A and 11A or Outside Mounted for Items 10B and 11B.
5. See Controls Section.

### Example:

PCB-1225 Clutch Brake per I-25608 - 90 Volt, Left hand hub, 2" Bore, Inside Mounted.

These units meet the standards of UL508 and are listed under guide card #NMTR2, file #59164. These units are CSA certified under file #LR11543.

\*See page 252 for specific part numbers.

Refer to Service Manual P-205.