

Clutch/Brake

PCB-1000 Heavy Duty

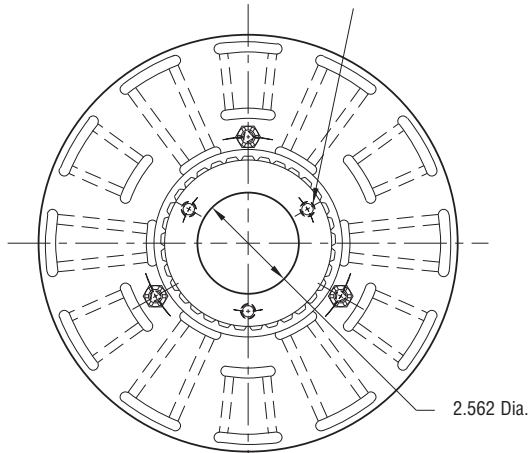

.397/.388 dia. (3) holes (hub) equally spaced on 3.187 dia. and within .003 of true position in relation to 4.001/3.999 pilot dia.



ARMATURE VIEW

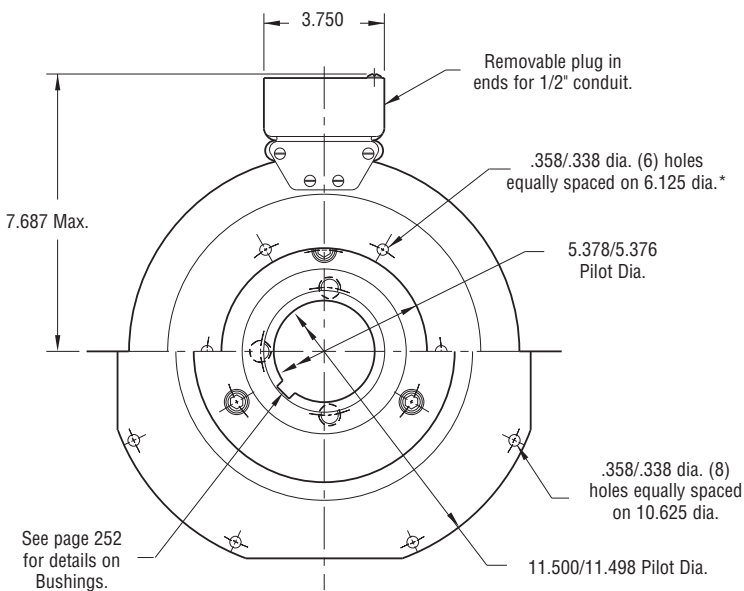

MAGNET VIEW
(Inside & Outside Mounted)

Customer Shall Maintain:

1. Concentricity of brake magnet mounting pilot diameter with mounting shaft within .010 T.I.R.
2. Squareness of brake magnet mounting face with magnet mounting shaft within .006 T.I.R.
3. Splined hub pilot diameter to be concentric with splined armature center of rotation within .010 T.I.R.

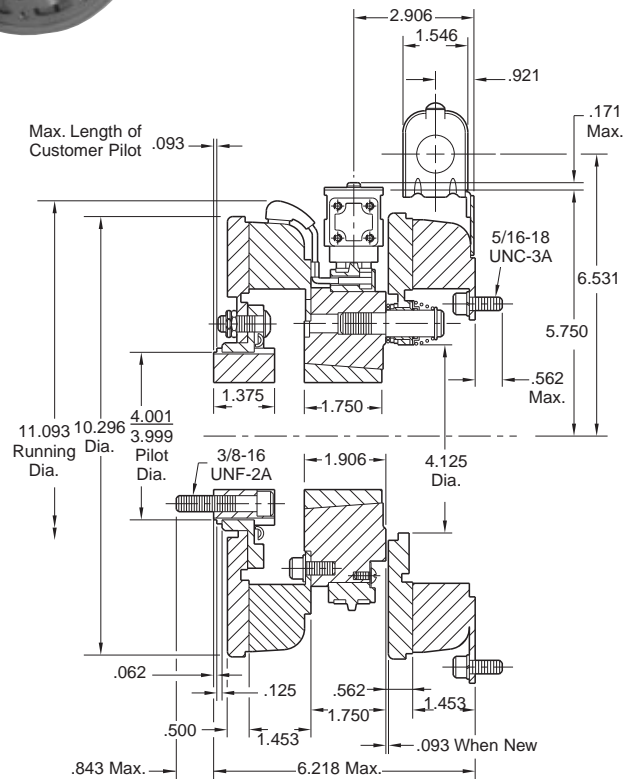

* Mounting holes are within .010 of true position relative to pilot diameter.

Shaft Size	.500 – 2.500
Static Torque	240 lb. ft.
Maximum Speed	3,600 rpm
Standard Voltage	D.C. 6, 24, 90

All dimensions are nominal unless otherwise noted.

Information on inertia and weights begins on page 239. Coil data is on pages 250 and 251.



Drawing I-25589

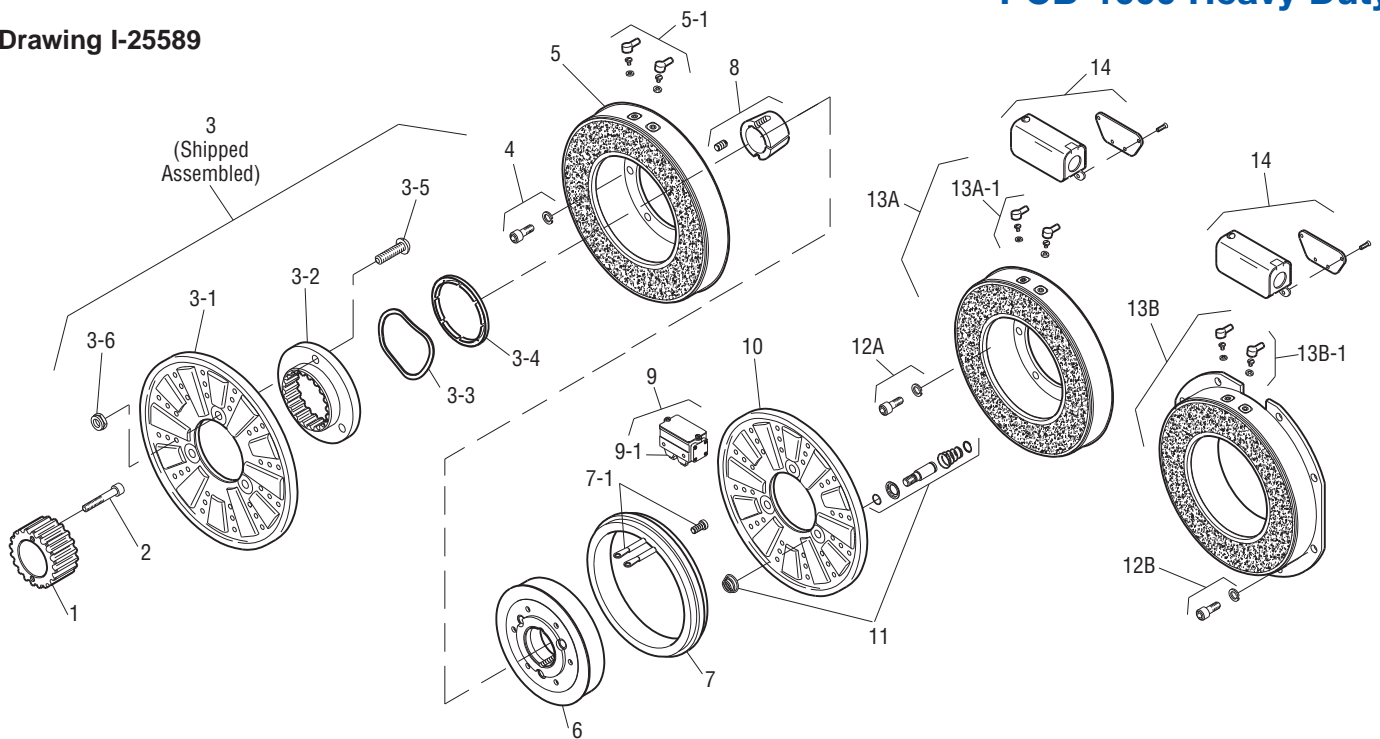

Item	Description	Part Number	Qty.
1	Splined Hub	540-0147	1
2	Mounting Accessory	5202-101-001	1
3	Armature Accessory	5322-111-002	1
3-1	Armature	5322-111-036	1
3-2	Armature Adapter	104-0009	1
3-3	Autogap Spring	808-0061	1
3-4	Retainer Ring	748-0374	1
3-5	Buttonhead Screw	797-0272	3
3-6	Locknut	661-0004	3
4	Mounting Accessory	5321-101-001	1
5	Magnet		1
	6 Volt	5302-631-003	
	24 Volt	5302-631-014	
	90 Volt	5302-631-005	
5-1	Terminal Accessory	5311-101-001	1
6	Magnet Hub		1
	Right Hand	5302-541-002	
	Left Hand (shown)	5302-541-001	
7	Collector Ring	5301-749-001	1
7-1	Collector Ring Accessory	5301-101-002	1
8	Bushing*	180-0185 to 180-0217	1
9	Brushholder	5300-178-001	1
9-1	Brush	176-0001	4
10	Armature	5302-111-013	1
11	Autogap Accessory	5201-101-008	3
12A	Mounting Accessory - I.M.	5321-101-001	1
12B	Mounting Accessory - O.M.	5321-101-002	2

Item	Description	Part Number	Qty.
13A	Magnet - Inside Mounted		1
	6 Volt	5312-631-004	
	24 Volt	5312-631-005	
	90 Volt	5312-631-006	
13A-1	Terminal Accessory	5311-101-001	1
13B	Magnet Hub - Outside Mounted		1
	6 Volt	5312-631-011	
	24 Volt	5312-631-013	
	90 Volt	5312-631-012	
13B-1	Terminal Accessory	5311-101-001	1
14	Conduit Box	5200-101-011	1

How to Order:

1. Specify Voltage for Item 5 and Item 13A or 13B.
2. Specify left hand or right hand hub for Item 6. Bushing enters from magnet side for L.H. hub and from hub side for R.H. hub.
3. Specify Bore Size for Item 7.
4. Specify Inside Mounted for Items 12A and 13A or Outside Mounted for Item 12B and 13B.
5. See Controls Section.

Example:

PCB-1000 Clutch Brake per I-25589 - 90 Volt, Left Hand hub, 1-1/2" Bore, Inside Mounted

These units meet the standards of UL508 and are listed under guide card #NMTR2, file #59164. These units are CSA certified under file #LR11543.

*See page 252 for specific part numbers.

Refer to Service Manual P-205.