

Clutch

PC-500

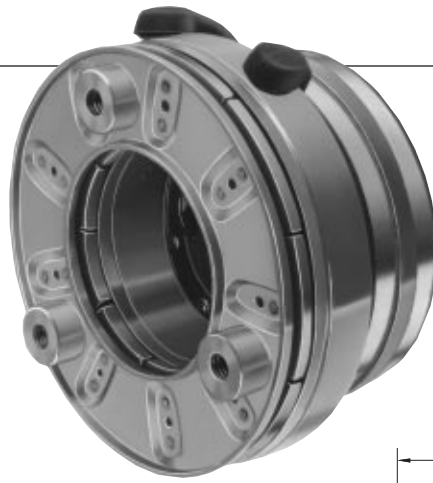

See page 230 for details on Drive Pin mountings.

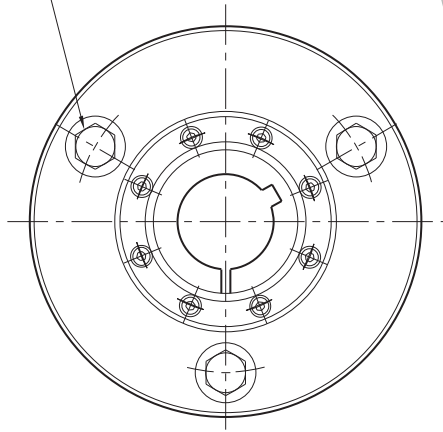

ARMATURE VIEW

1/2-14 NPSM Am. std. straight pipe tap.

See page 252 for details on Bushings.

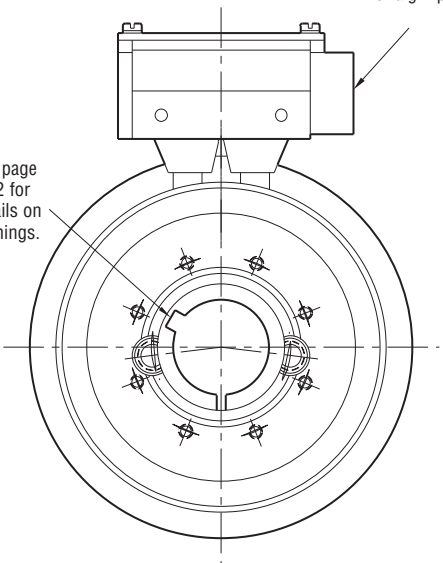

MAGNET VIEW

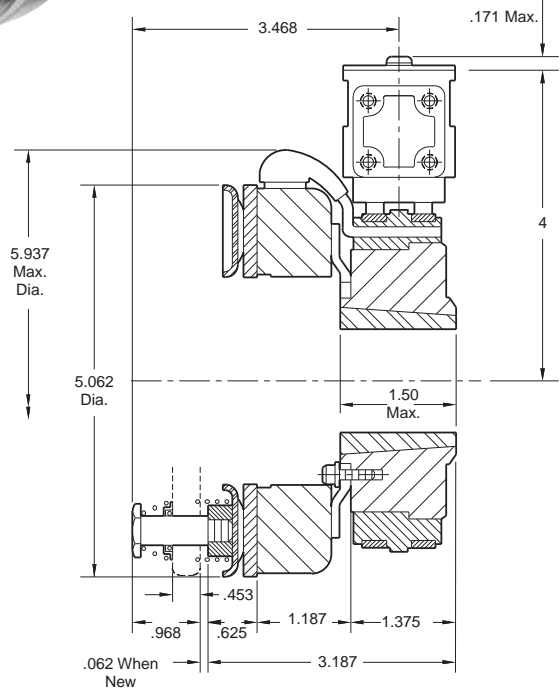

Shaft Size	.500 – 1.250
Static Torque	40 lb.ft.
Maximum Speed	5,400 rpm
Standard Voltage	D.C. 6, 24, 90

All dimensions are nominal unless otherwise noted.

Information on inertia and weights begins on page 239. Coil data is on pages 250 and 251.

Customer Shall Maintain:

1. Armature mounting to be concentric with magnet hub assembly within .006 T.I.R.



Drawing I-25716

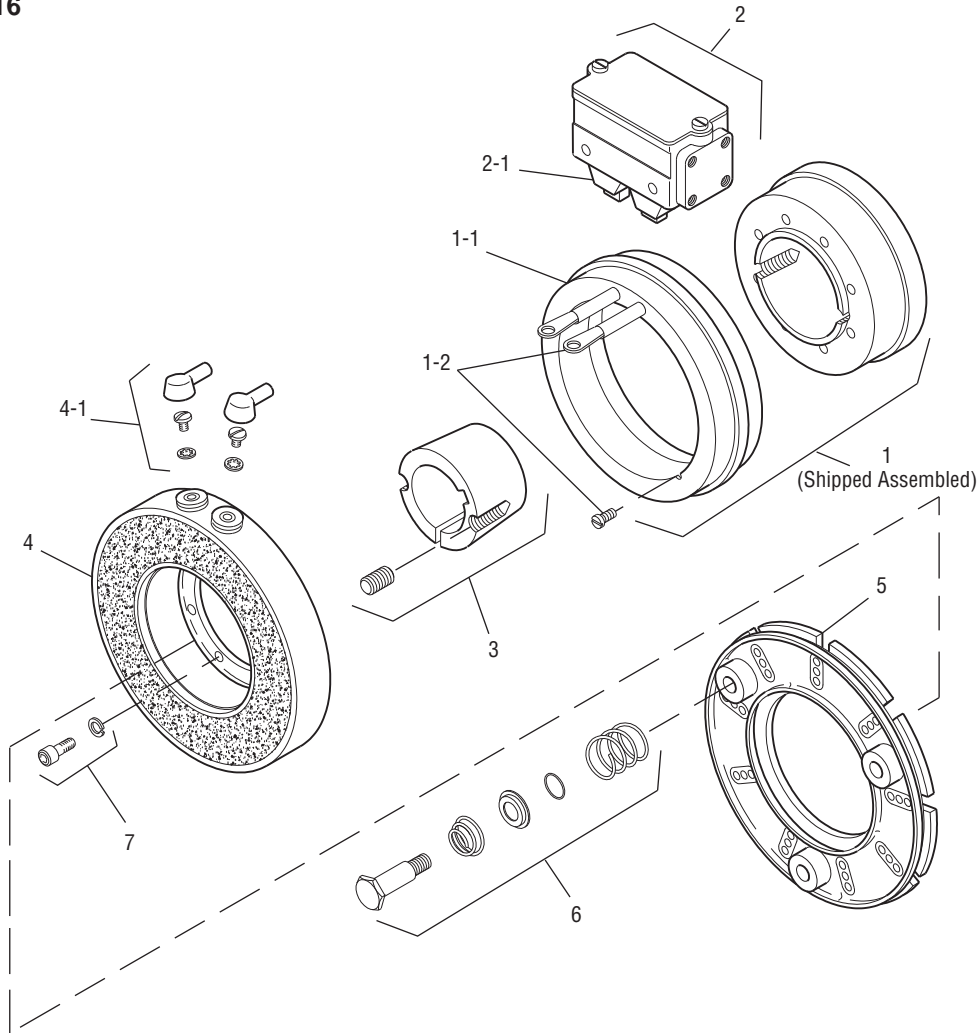

Item	Description	Part Number	Qty.
1	Magnet Hub	5300-541-001	1
1-1	Collector Ring	5300-749-001	1
1-2	Collector Ring Mounting Acc.	5300-101-002	1
2	Brushholder	5300-178-001	1
2-1	Brush	176-0001	4
3	Bushing*		1
	1/2" to 1-1/4" Bore	180-0116 to 180-0128	
4	Magnet		1
	6 Volt.	5300-631-002	
	24 Volt	5300-631-003	
	90 Volt	5300-631-005	
4-1	Terminal Accessory	5311-101-001	1
5	Armature	5300-111-002	1
6	Autogap Accessory	5200-101-009	3
7	Mounting Accessory	5102-101-001	2

How to Order:

1. Specify Bore Size for Item 3.
2. Specify Voltage for Item 4.
3. See Controls Section.

Example:

PC-500 Clutch per I-25716 - 90 Volt
3/4" Bore

These units, when used in conjunction with the correct Warner Electric conduit box, meet the standards set of UL508 and are listed under guide card #NMTR2, file #59164.

These units are CSA certified under file #LR11543.

*See page 252 for specific part numbers.

Refer to Service Manual P-203.