

Clutch

PC-1225 Heavy Duty

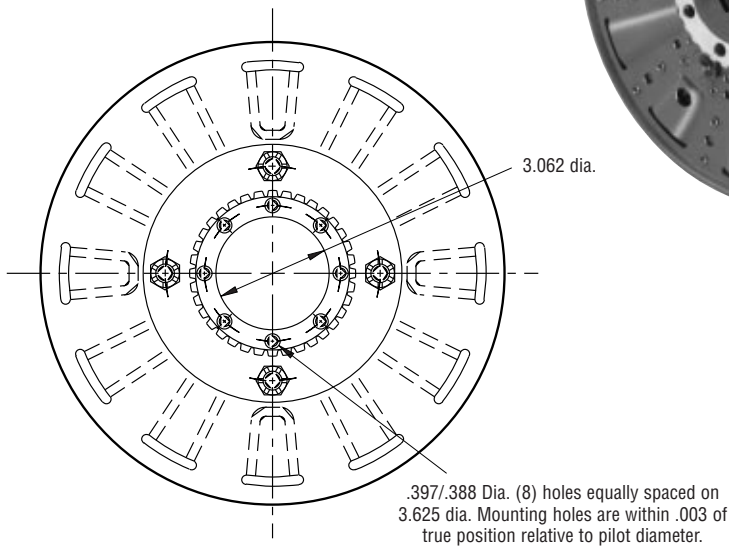

ARMATURE VIEW

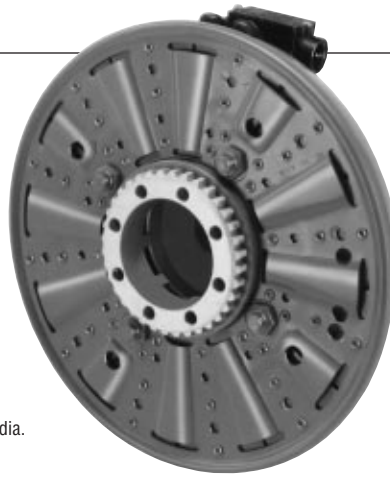
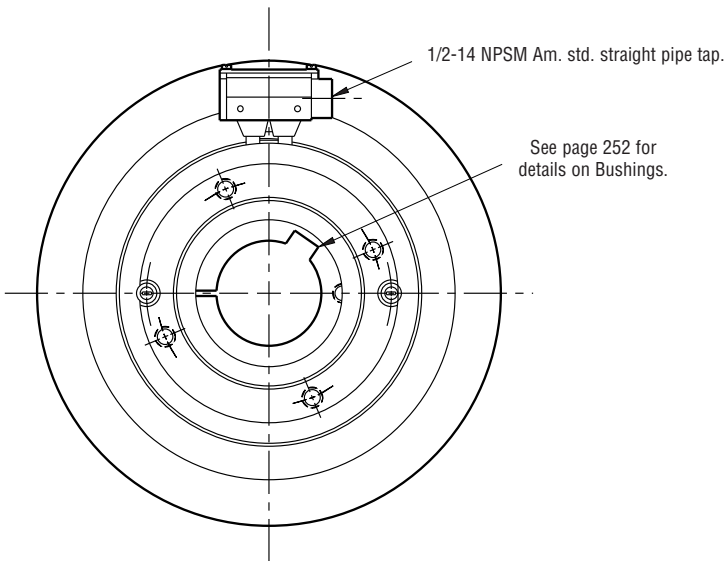

COLLECTOR RING VIEW

Customer Shall Maintain:

1. Splined hub pilot diameter to be concentric with splined armature center of rotation within .010 T.I.R.

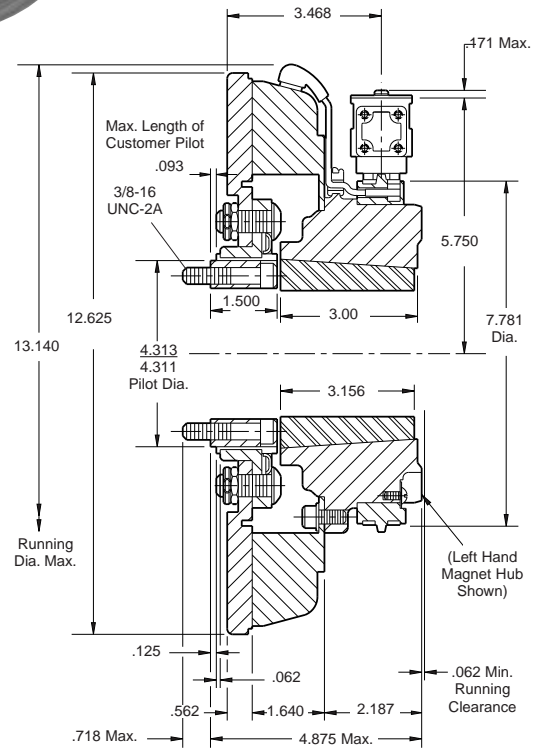

Shaft Size	.937 – 3.000
Static Torque	465 lb.ft.
Maximum Speed	3,000 rpm
Standard Voltage	D.C. 6, 24, 90

All dimensions are nominal unless otherwise noted.

Information on inertia and weights begins on page 239. Coil data is on pages 250 and 251.



Drawing I-25603

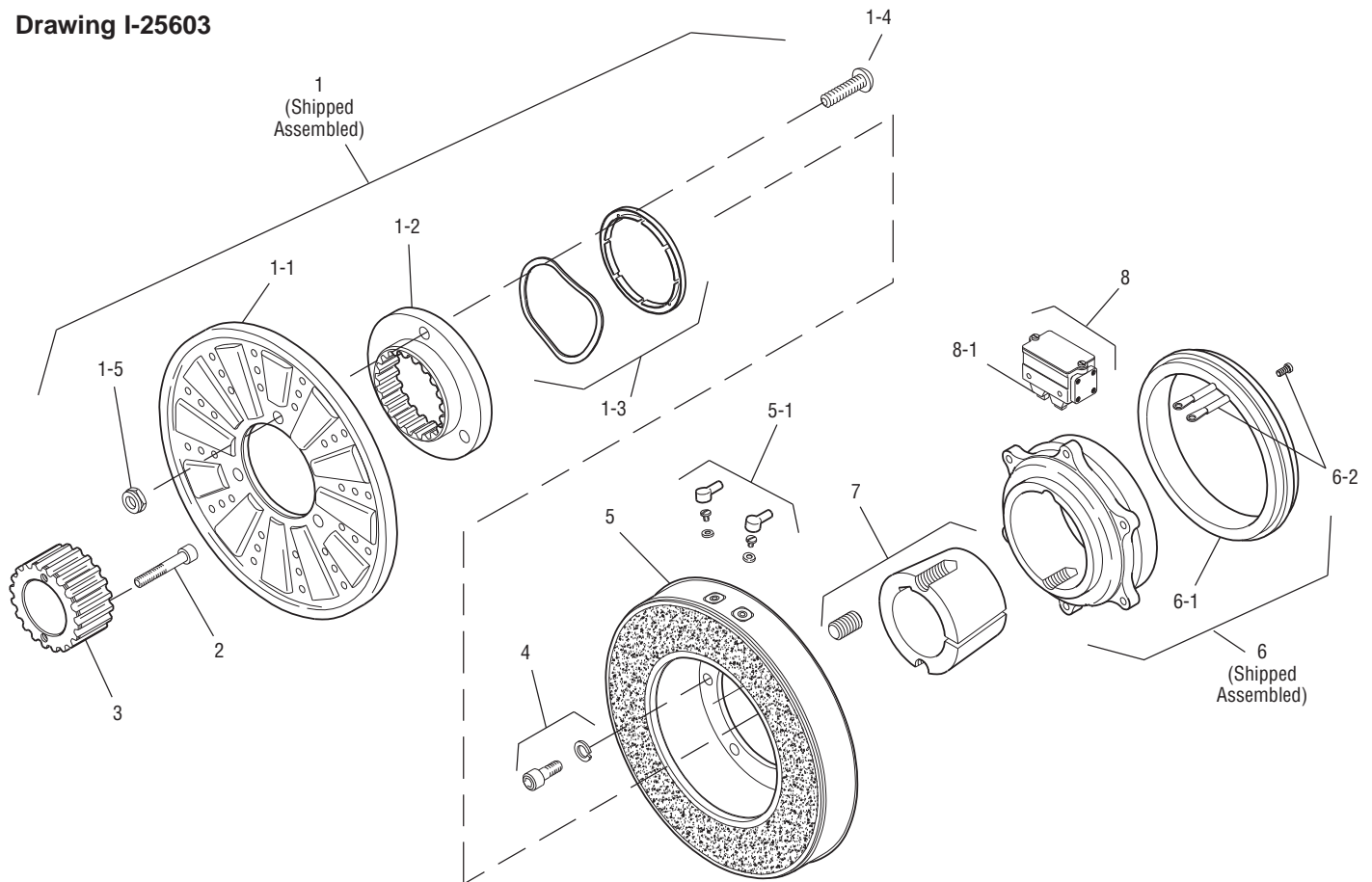

Item	Description	Part Number	Qty.
1	Armature & Splined Adapter Assembly	5323-111-001	1
1-1	Armature	5323-111-034	1
1-2	Splined Armature Adapter	104-0010	1
1-3	Autogap Accessory	5323-101-002	1
	Autogap Spring	808-0044	1
	Retainer Ring	748-0370	1
1-4	Button Head Screw	797-0281	4
1-5	Locknut	661-0005	4
2	Mounting Accessory	5202-101-001	1
3	Splined Hub	540-0148	1
4	Mounting Accessory	5321-101-001	1
5	Magnet		1
	6 Volt	5303-631-005	
	24 Volt	5303-631-007	
	90 Volt	5303-631-008	
	†90 Volt LK Facing	5303-631-001	
5-1	Terminal Accessory	5311-101-001	
6	Magnet Hub Assembly		1
	Right Hand	5303-541-002	
	Left Hand (shown)	5303-541-001	

Item	Description	Part Number	Qty.
6-1	Collector Ring	5301-749-001	1
6-2	Collector Ring Accessory	5303-101-004	1
7	Bushing, Taperlock*	180-0262 to 180-0295	1
8	Brushholder	5300-178-001	1
8-1	Brush	176-0001	4

How to Order:

1. Specify Voltage for Item 5.
2. Specify Bore Size for Item 7.
3. Specify left hand or right hand hub for Item 6.
4. See Controls Section.

Example:

PC-1225 Clutch per I-25603 - 90 Volt, L.H. hub, 1" Bore

These units meet the standards of UL508 and are listed under guide card #NMTR2, file #59164.

These units are CSA certified under file #LR11543.

*See page 252 for specific part numbers.

Refer to Service Manual P-206.

†Optional LK facing available. For more information, see page 232.