

# Clutch

## PC-1000 Normal Duty

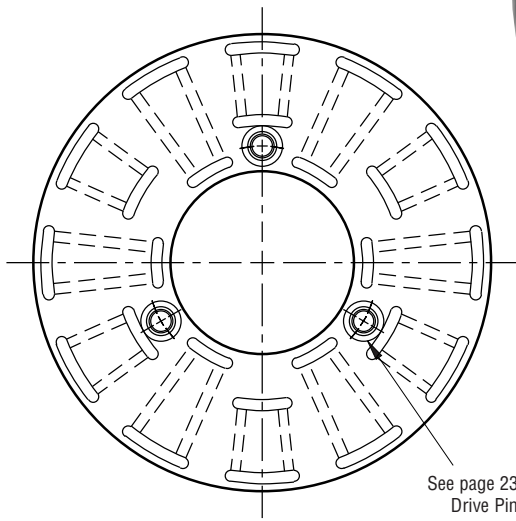

See page 230 for details on Drive Pin mountings.

### ARMATURE VIEW

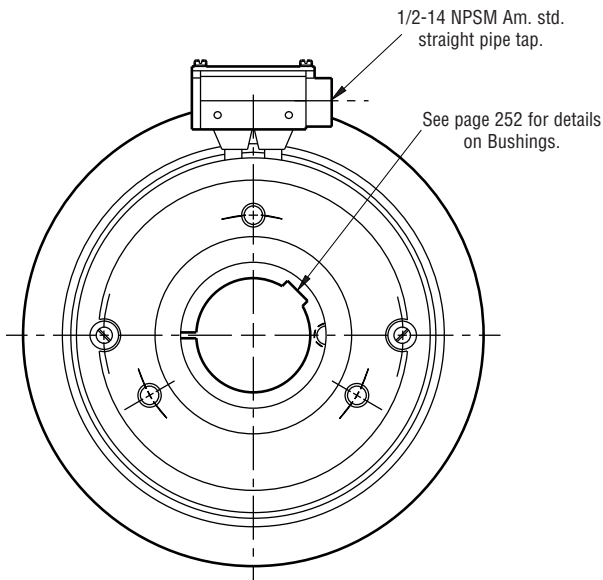

1/2-14 NPSM Am. std. straight pipe tap.

See page 252 for details on Bushings.

### COLLECTOR RING VIEW

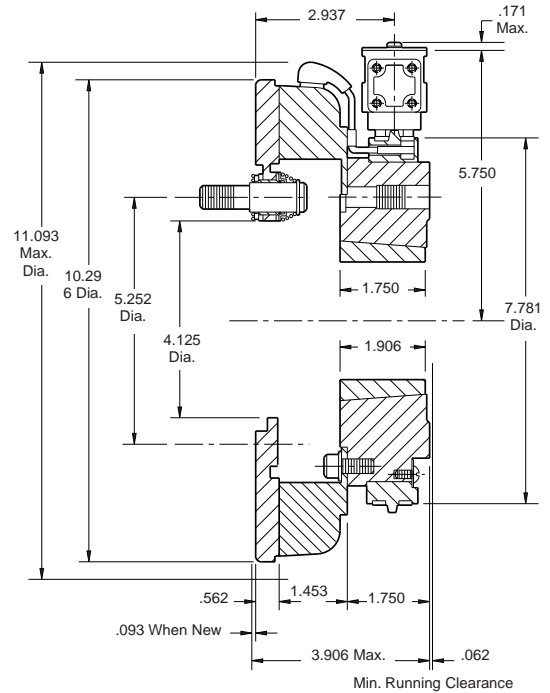

Shaft Size	.500 – 2.500
Static Torque	240 lb.ft.
Maximum Speed	3,600 rpm
Standard Voltage	D.C. 6, 24, 90

All dimensions are nominal unless otherwise noted.

Information on inertia and weights begins on page 239. Coil data is on pages 250 and 251.



Drawing I-25582

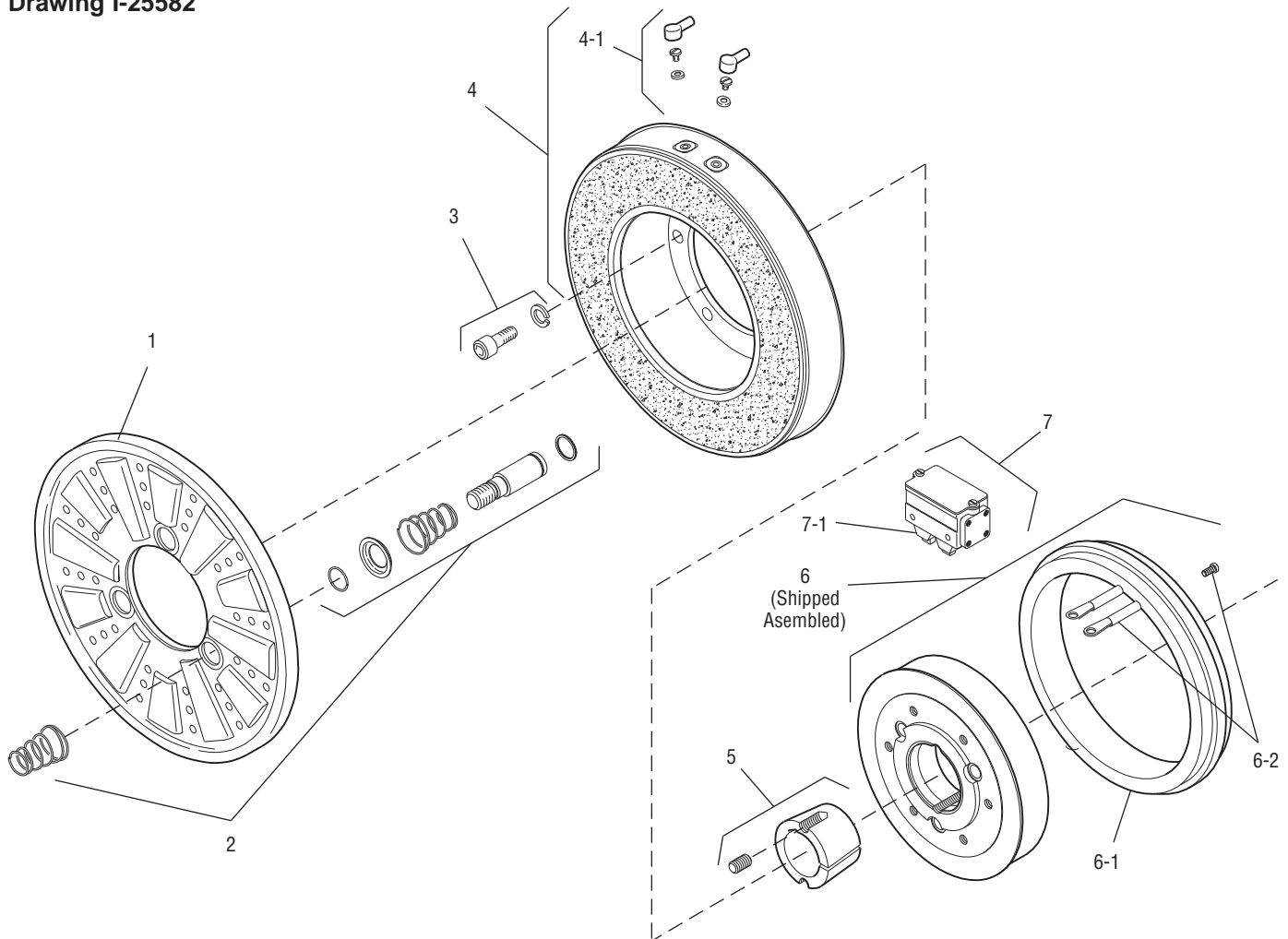

Item	Description	Part Number	Qty.
1	Armature	5302-111-013	1
2	Autogap Accessory	5201-101-008	3
3	Mounting Accessory	5321-101-001	1
4	Magnet		1
	6 Volt	5302-631-003	
	24 Volt	5302-631-014	
	90 Volt	5302-631-005	
	†90 Volt LK Facing	5302-631-001	
4-1	Terminal Accessory	5311-101-001	1
5	Bushing*		1
	1/2" to 2-1/2" Bore	180-0185 to 180-0217	
6	Magnet Hub		1
	Left Hand (shown)	5302-541-001	
	Right Hand	5302-541-002	
6-1	Collector Ring	5301-749-001	1
6-2	Collector Ring Accessory	5302-101-002	1
7	Brushholder	5300-178-001	1

Item	Description	Part Number	Qty.
7-1	Brush	176-0001	4

### How to Order:

1. Specify Voltage for Item 4.
2. Specify Bore Size for Item 5.
3. Specify left hand or right hand hub for Item 6. (Bushing enters from magnet side for L.H. hub and from hub side for R.H.)
4. See Controls Section.

### Example:

PC-1000 Clutch per I-25582 - 90 Volt, L.H. hub, 1" Bore

These units meet the standards of UL508 and are listed under guide card #NMTR2, file #59164.

These units are CSA certified under file #LR11543.

\*See page 252 for specific part numbers.

Refer to Service Manual P-206.

†Optional LK facing available. For more information, see page 232.