

Brake

PB-170

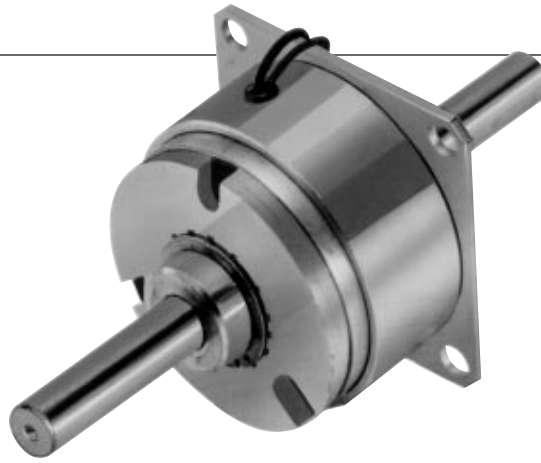

For Bore sizes see chart below.

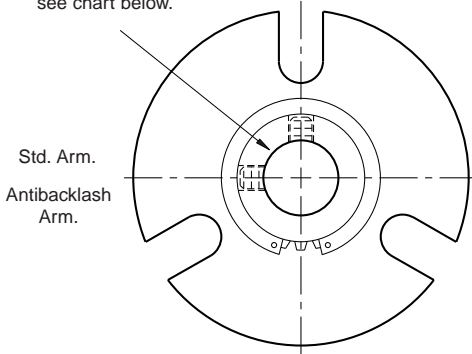

ARMATURE VIEW

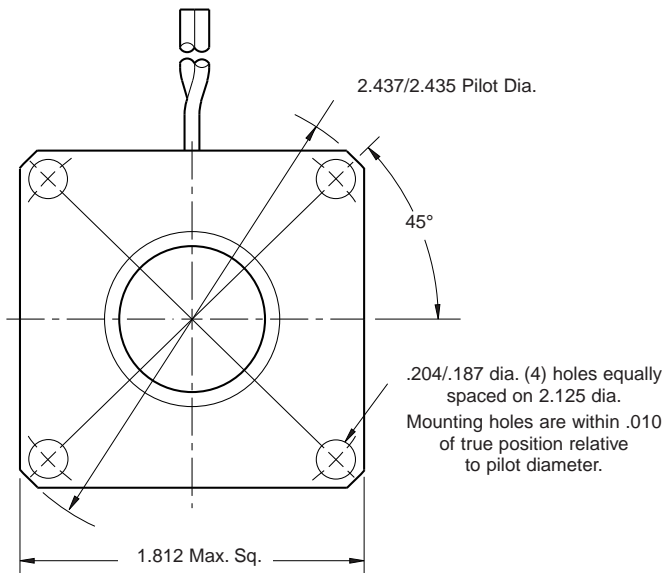

MAGNET VIEW

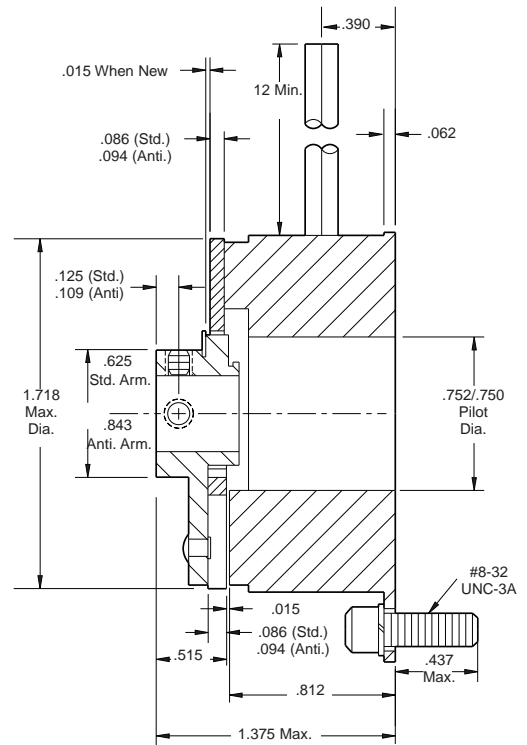

Bore Dimensions

Armature Bore Dia.
.251/.250
.313/.312
.376/.375

Static Torque	15 lb.in.
Maximum Speed	10,000 rpm
Standard Voltage	D.C. 6, 24, 90

All dimensions are nominal unless otherwise noted.

Information on inertia and weights begins on page 239. Coil data is on pages 250 and 251.

Customer Shall Maintain:

1. Squareness of brake mounting face with armature shaft within .006 T.I.R.
2. Concentricity of brake mounting pilot diameter with armature shaft within .010 T.I.R.



Drawing I-25753

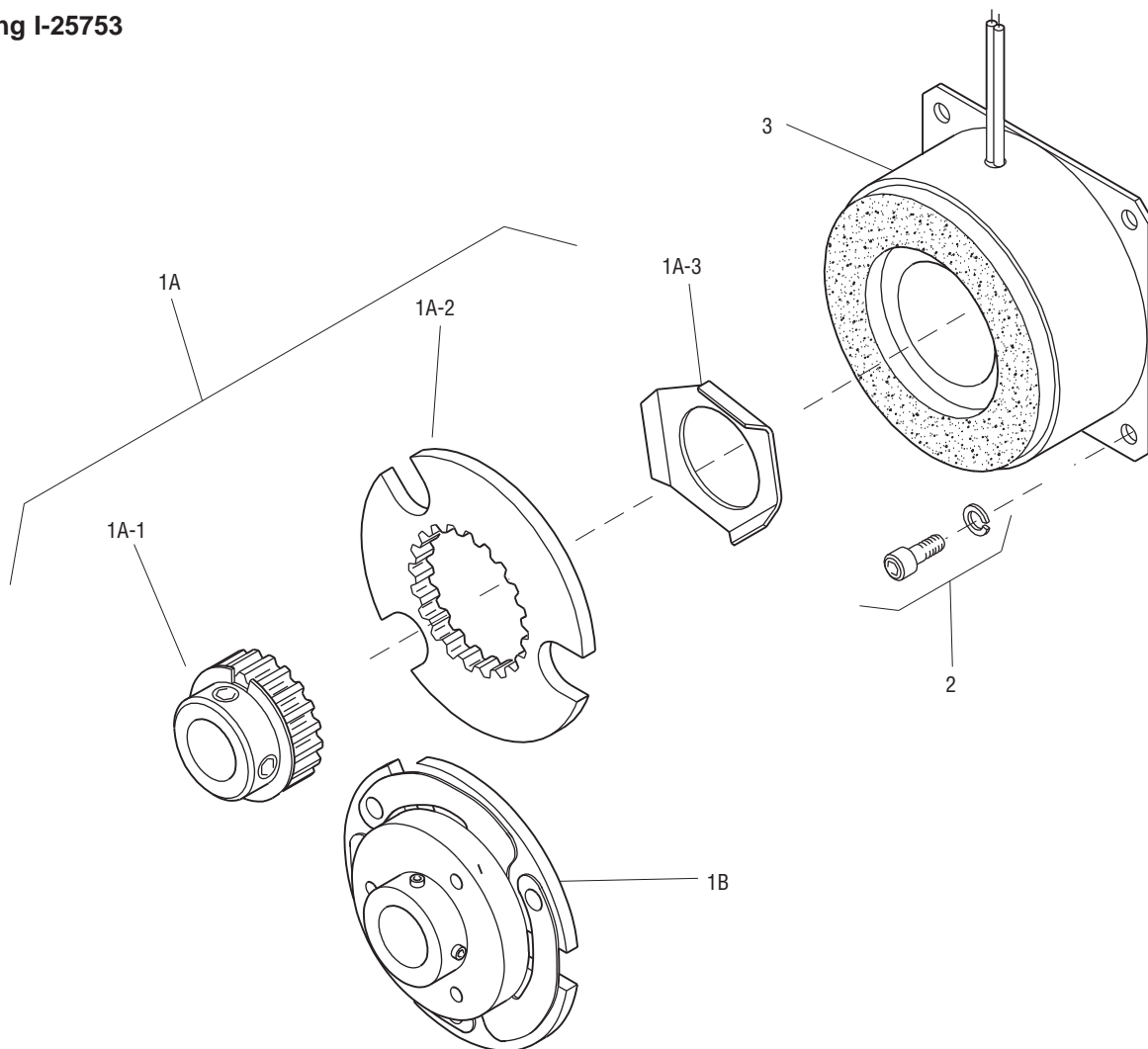

Item	Description	Part Number	Qty.
1A	Armature and Hub		
1A-1	Armature Hub		1
	1/4" Bore	5102-541-002	
	5/16" Bore	5102-541-003	
	3/8" Bore	5102-541-004	
1A-2	Armature	110-0111	1
1A-3	Release Spring	808-0019	1
1B	Antibacklash Armature		1
	1/4" Bore	5623-111-008	
	5/16" Bore	5623-111-009	
	3/8" Bore	5623-111-010	
2	Mounting Accessory	5102-101-001	1
3	Magnet		1
	6 Volt	5375-631-003	
	24 Volt	5375-631-005	
	90 Volt	5375-631-007	

How to Order:

1. Specify Type of Armature Desired.
2. Specify Bore Size for Item 1A-1 or 1B.
3. Specify Voltage for Item 3.
4. See Controls Section.

Example:

PB-170 Brake per I-25753 - 90 Volt,
Antibacklash Armature
1/4" Armature Hub Bore

These units meet the standards of UL508 and are listed under guide card #NMTR2, file #59164.

These units are CSA certified under file #LR11543.

Refer to Service Manual P-201.