

Motor Brake

Heavy Duty

MB-1225 Flange Mounted

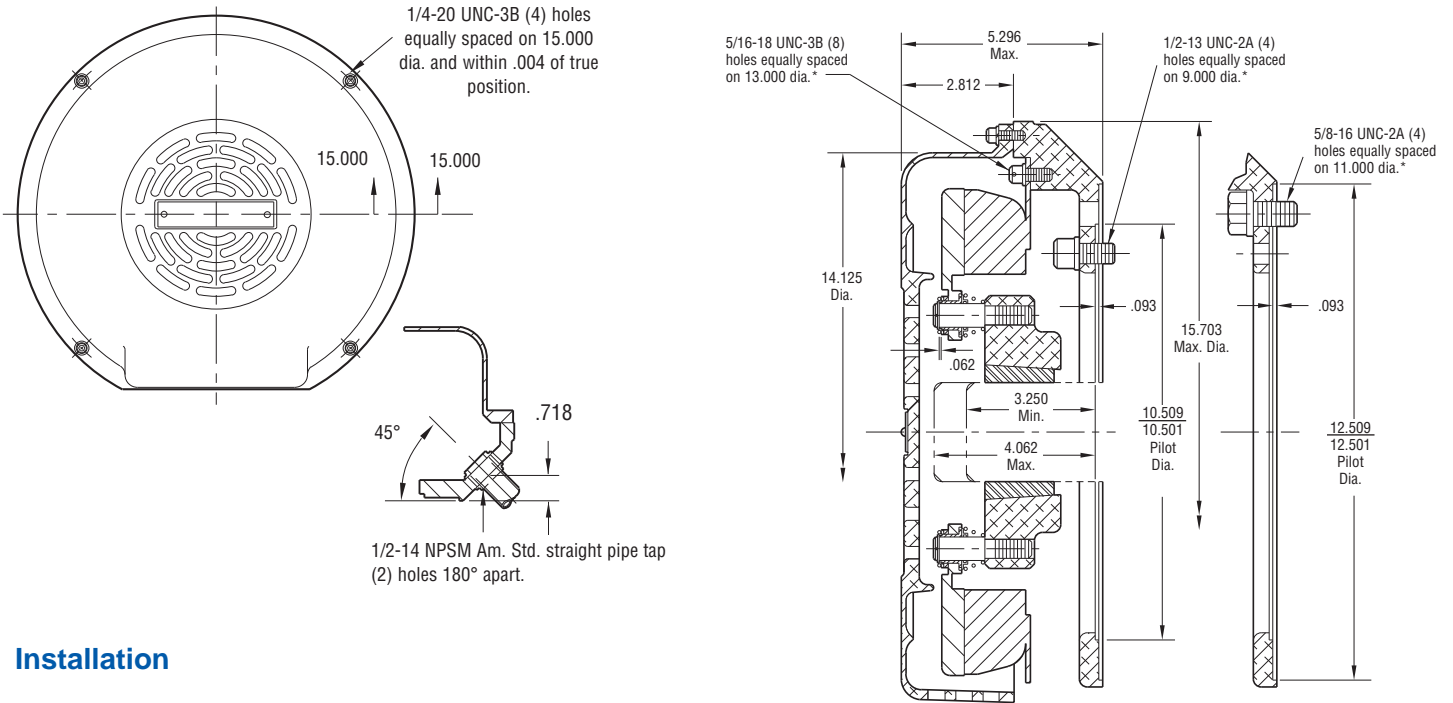

Installation

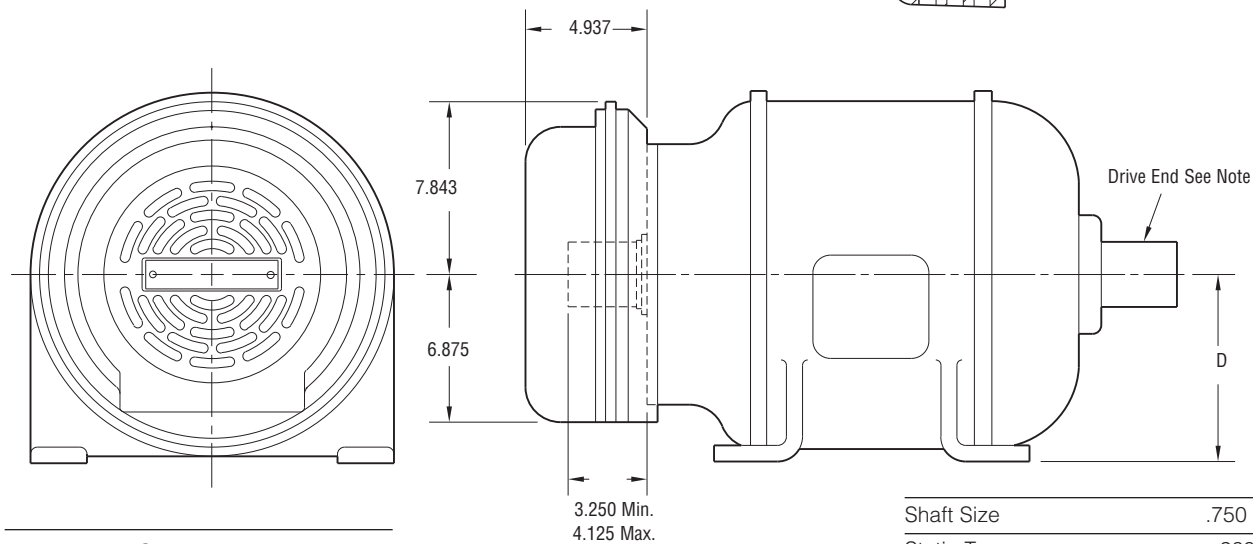

NEMA Frame Sizes	Dim. D
284C & 286C or TC	7
324C & 326C or TC	8
364C & 365C or TC	9

Shaft Size	.750 – 2.687
Static Torque	260 lb. ft.
Maximum Speed	3,000 rpm
Standard Voltage	D.C. 90

All dimensions are nominal unless otherwise noted.

Information on inertia and weights begins on page 239. Coil data is on pages 250 and 251.



Drawing I-25618

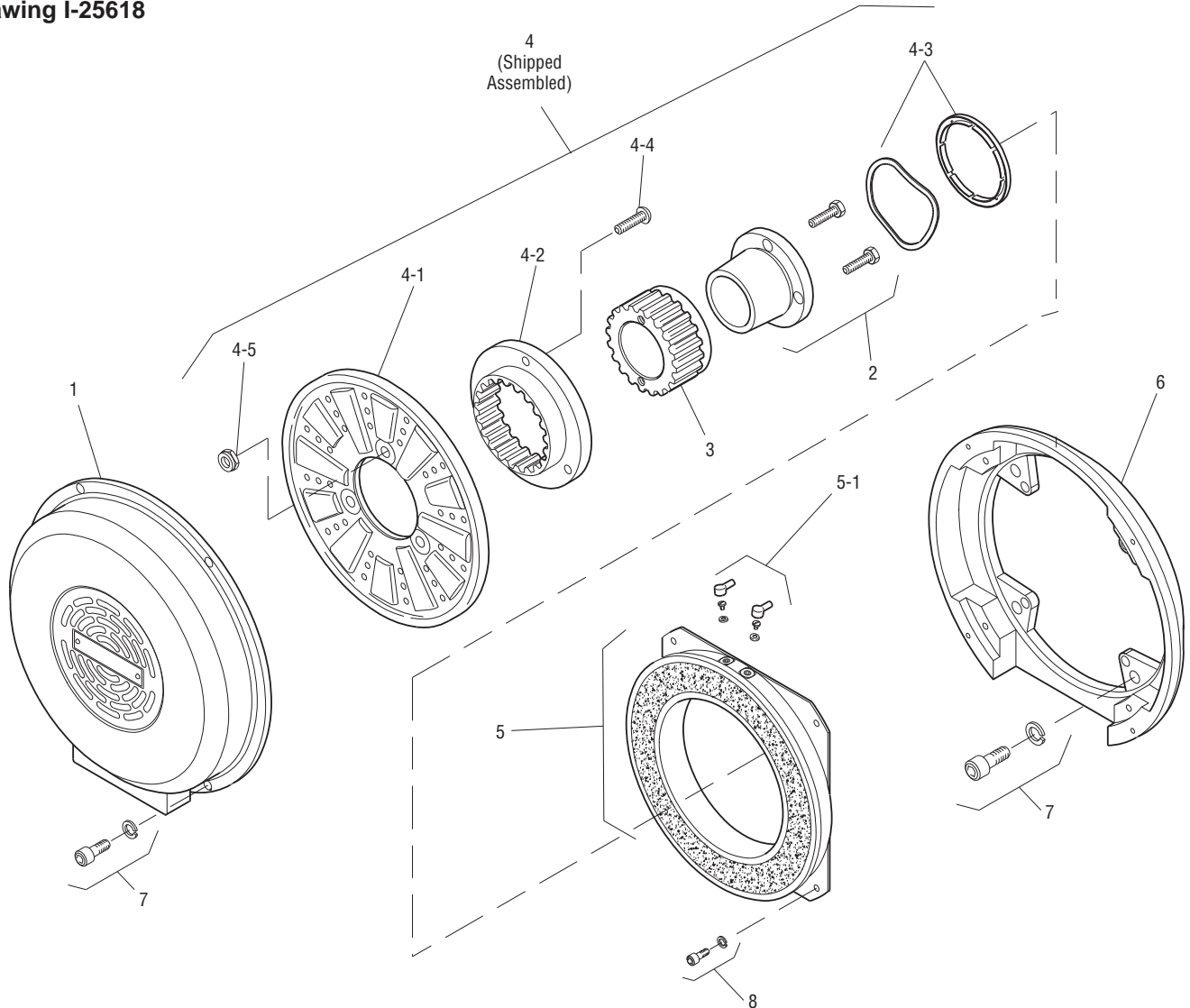

Item	Description	Part Number	Qty.
1	Cover	5353-288-001	1
2	Bushing*		1
	3/4" to 2-11/16" Bore	180-0026 to 180-0057	
3	Armature Hub	540-0064	1
4	Armature Assembly	5323-111-001	1
4-1	Armature	5323-111-034	1
4-2	Splined Adapter	104-0010	1
4-3	Autogap Accessory	5323-101-002	1
4-4	Screw	797-0281	4
4-5	Locknut	661-0005	4
5	Magnet	5353-631-001	1
5-1	Terminal Accessory	5311-101-001	1
6	Adapter	5353-105-002	1
7	Mounting Accessory	5351-101-003	2
8	Mounting Accessory	5321-101-002	1

How to Order:

1. MB-1225 Adapts to NEMA C Face, Double Shaft Motors, Frame Sizes 284, 284 UC, 324 UC, 326 UC, 364 UC and 365 UC.
2. Specify Bore Size for Item 2. (Frame size determines bore).
3. See Controls Section.

Example:

MB-1225 Motor Brake per I-25618 - 90 Volt, 1-5/8" Bore
 These units meet the standards of UL508 and are listed under guide card #NMTR2, file #59164. These units are CSA certified under file #LR11543.

*See page 252 for specific part numbers.

Refer to Service Manual P-208.