

Force Limiters

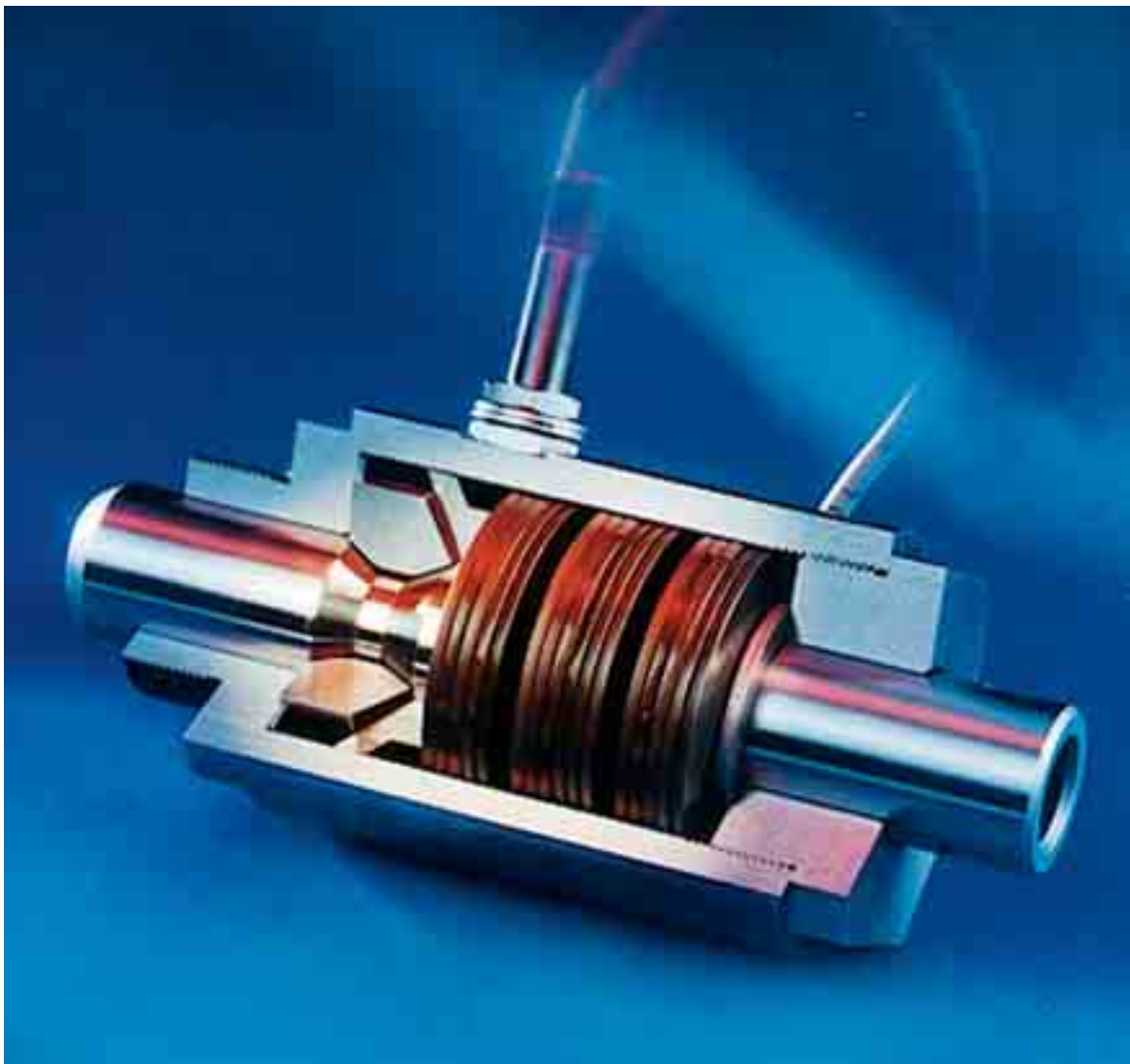

49

RINGSPANN[®] Registered Trademark of RINGSPANN GmbH, Bad Homburg

Why RINGSPANN Force Limiters?

Why RINGSPANN Force Limiters?

There are many ways of transmitting forces and torques in machines, installations and vehicles. The advances in constructional engineering are marked by components which run faster and are of a lighter construction. Therefore it has become necessary to provide for safety elements at the critical points. Until now these were usually in the shape of overload clutches on rotating shafts which, once the maximum torque was exceeded, would either slip, stop, or automatically cut out.

However, many machines and installations have elements which transmit longitudinal forces. To prevent damage and breakdowns a solution for limiting the amount of these forces has to be found. RINGSPANN has designed a series of Force Limiters, outstanding in that forces up to a certain size can be transmitted in both directions completely free of play and rigid. On exceeding the preset disengaging force F_A the power of the force is interrupted and the output part is no longer driven.

After the overload has been cleared the driving part and the driven part are aligned towards each other and the Force Limiter re-engages automatically. The Force Limiter can be fitted with non-contact proximity switch to give early warning of reaching a certain force, or disengaging signal.

Application Example

Shown in ill. 1 is the operation of the feeding equipment for workpieces on an interlinked installation. The feeding equipment is driven by a crankshaft pin on the output shaft via a connecting rod and a lever. The Force Limiter with non-contact proximity switch is built into the connecting rod as shown in ill. 1.

If the material jams the force in the connecting rod increases considerably, causing extensive damage in the machine if there is no safety installation available. The Force Limiter ensures that no excessive high forces reach the feed mechanism. If the force in the Force Limiter exceeds its present limit it disengages and, through the non-contact proximity switch, a signal is given to switch off the drive.

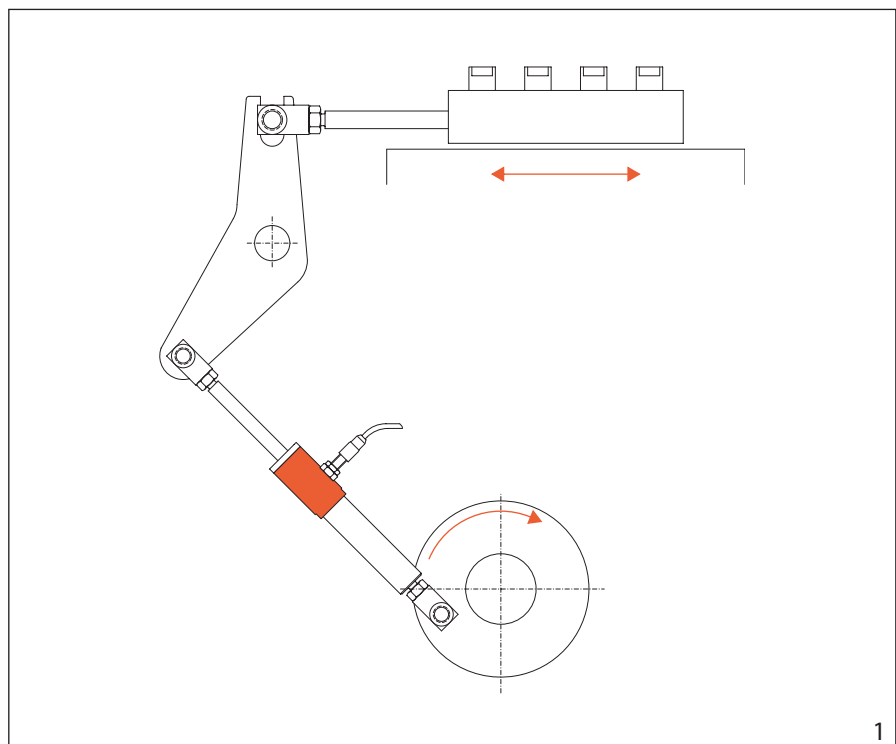

Force Limiters PA

Assembly and Operation

Assembly and operation of the RINGSPANN Force Limiter PA can be seen in illustrations 2 and 5. The sectional drawing in ill. 2 shows the standard type of basic unit. The rod 1 is connected with the housing 3 via locking segments 2. The locking segments 2 are pressed into the groove 5 of the rod and against the conical surface 6 of the slide ring via the disc spring pack 4. If a force is effective between the rod and the housing, then, according to ill. 5, up to force F_B no movement takes place between the two parts. If the force is increased the rod moves relative to the housing until the disengaging force F_A is reached. The force then drops to the value F_C . The loss of force down to F_C is effected according to the direction C. The maximum possible operating force should always be less than F_B and considerably more than F_C . With the RINGSPANN Force Limiter F_B is always larger than $0,7 \times F_A$ and F_C is ca. $0,2 \times F_A$.

This disengaging force F_A can easily be adjusted by changing the number of washers 7. The nut 8 is always tightened against the housing to prevent unauthorised increase of the disengaging force.

Ill. 3 and 4 show the Force Limiter in the disengaged position with the force effective towards the right and left respectively. In both cases one can see clearly that in this position the locking segments are clear of the groove in the rod, the springs are at maximum pressure.

Advantages

- Forces limited in both directions
- High response accuracy
- Automatic re-engagement
- Maintenance-free
- Robust construction
- Uncomplex design
- Easy to build on
- For disengaging forces up to 140 000 N
- Disengaging force finely adjustable

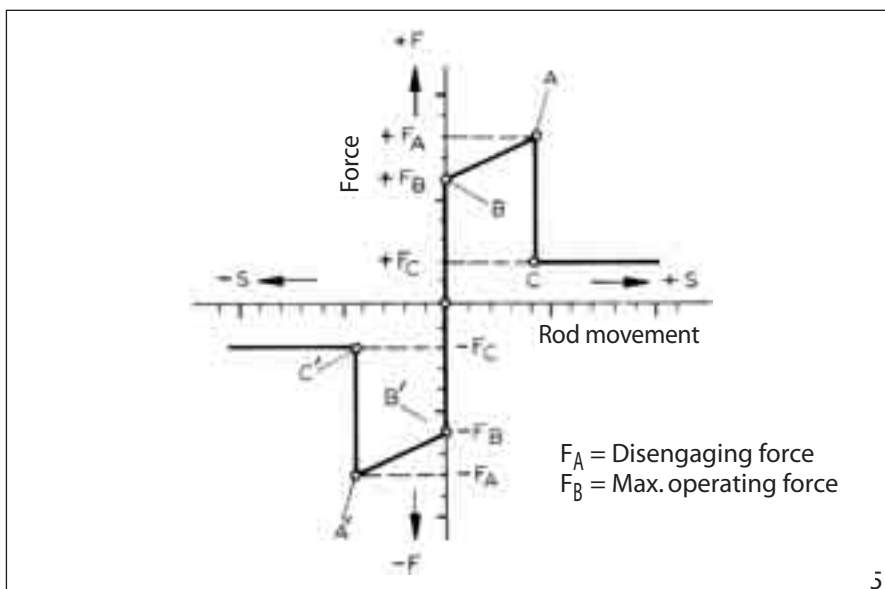
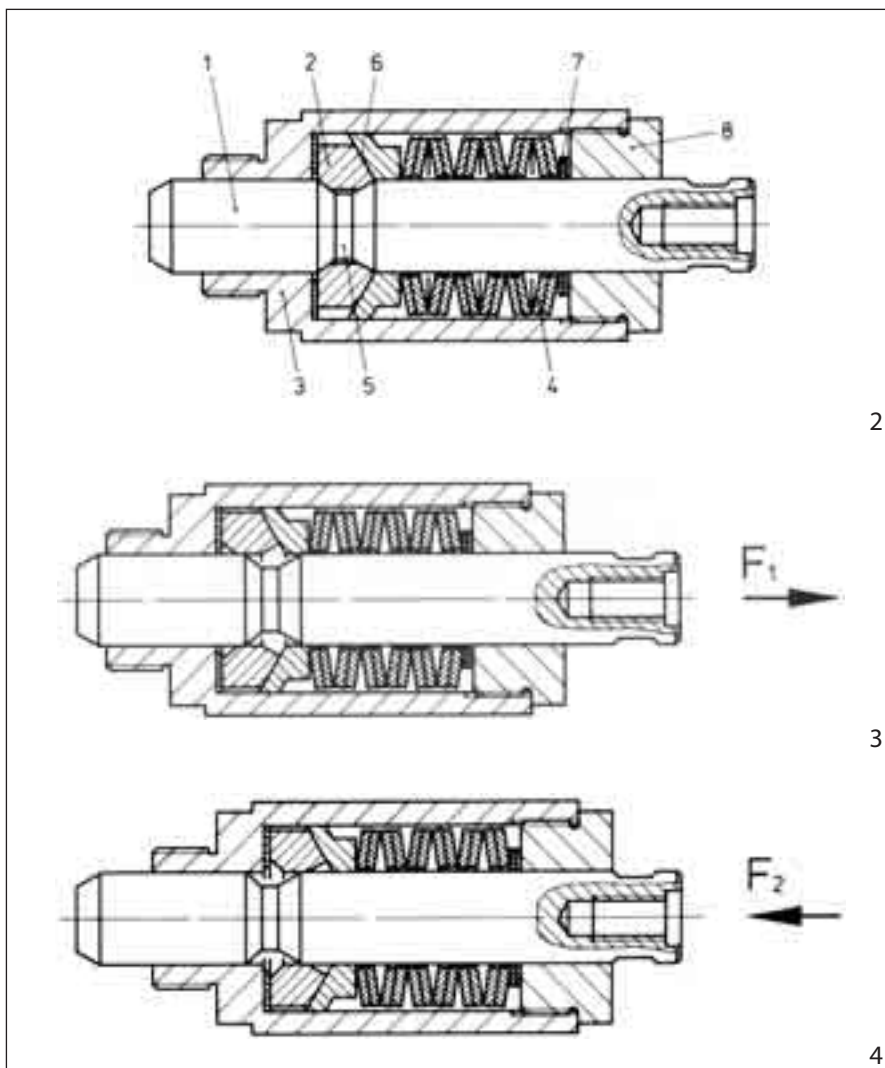

Force Limiters PA

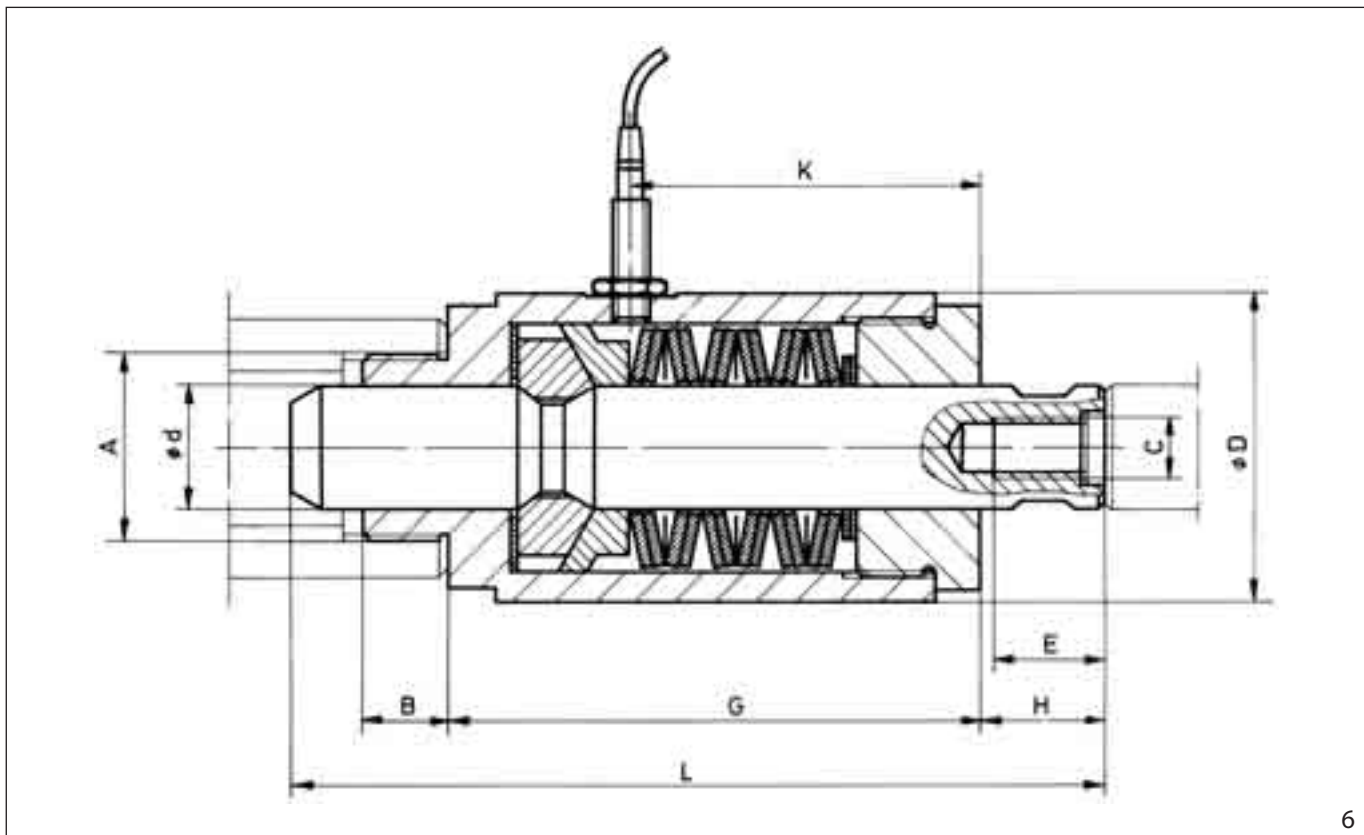

6

Technical Data and Dimensions

Type	Max. Disengaging Force F_A N	d mm	A	B mm	C	D mm	E mm	G mm	H mm	K mm	L mm
PA 12	3600	12	M20 x 1,5	10	M6	32	10	61	16	38	95
PA 20	10000	20	M30 x 1,5	15	M10	50	16	85	20	57	132
PA 30	22000	30	M45 x 1,5	20	M16	75	25	120	24	78	180
PA 50	62000	50	M70 x 2	28	M24	132	40	212	36	150	300
PA 75	140000	75	M100 x 2	40	M36	200	60	315	57	215	450

Accessories

- Non-contact proximity switch to stop the drive motor
- Non-contact proximity switch to signal excess force

Ordering

Please indicate the required disengaging force on your order. The Force Limiter can be supplied with preset disengaging force on request.

Other rod lengths and -connections available as special types.

We shall be pleased to advise you on the correct choice and dimension of a suitable Force Limiter.

Questionnaire for the selection of RINGSPANN Force Limiters

please photocopy

Company:	Departament/Contact:									
Address:	Name:									
.....	Enquiry no.:									
Telephone:	Date:									
Telefax:	e-mail:									
1. Type of machine into which the Force Limiter is to be installed									
2. Force Limiter use	In the case of overload the force limiter must: <input type="checkbox"/> Disengage <input type="checkbox"/> Only follow a particular path without disengaging <input type="checkbox"/> Trigger an electrical signal									
3. Force Limiter function	In the case of overload the force limiter must: <input type="checkbox"/> Operate or disengage in both directions <input type="checkbox"/> Only operate or disengage if there is compressive load <input type="checkbox"/> Only operate or disengage if there is tensile load									
4. Manifestation of force?	<input type="checkbox"/> Non-recurrent or occasional adjustment of disengaging force: Disengaging force F_A :.....N <input type="checkbox"/> Frequent change in disengaging force required: Disengaging force F_A adjustable from toN <table style="width: 100%; border: none;"> <tr> <td></td> <td style="text-align: center;">Upon pull</td> <td style="text-align: center;">Upon pressure</td> </tr> <tr> <td>Operating force [N]</td> <td style="text-align: center;">.....</td> <td style="text-align: center;">.....</td> </tr> <tr> <td>Disengagement path [mm]</td> <td style="text-align: center;">.....</td> <td style="text-align: center;">.....</td> </tr> </table> <ul style="list-style-type: none"> • Operating force is the force which the Force Limiter has to transmit without disengaging or following a particular path. • Disengagement path is the maximum change in length of the Force Limiter when it disengages. 		Upon pull	Upon pressure	Operating force [N]	Disengagement path [mm]
	Upon pull	Upon pressure								
Operating force [N]								
Disengagement path [mm]								
5. Connection	<input type="checkbox"/> Standard types as per catalogue 49 <input type="checkbox"/> With rod connection as per sketch <input type="checkbox"/> With housing connection as per sketch									
6. Installation conditions	<input type="checkbox"/> In enclosed machine housing <input type="checkbox"/> Exposed, but in enclosed space <input type="checkbox"/> Oil bath or oil fog <input type="checkbox"/> Outside, ambient temperature from°C to°C Other (e.g. accessibility, dust and other environmental factors which may be significant):									
7. Non-contact proximity switch	<input type="checkbox"/> Non-contact proximity switch <input type="checkbox"/> Complete with installed and adjusted non-contact proximity switch <input type="checkbox"/> With location borehole for non-contact proximity switch									



Freewheels

Backstops

Automatic protection against reverse running of conveyor belts, elevators, pumps and fans.



Catalogue 88

Overrunning Freewheels

Automatic engaging and disengaging of drives.



Catalogue 80

Housing Freewheels

Automatic engaging and disengaging for multi-motor drives for installations with continuous operation.



Catalogue 80.1

Indexing Freewheels

For gradual feed of materials.



Catalogue 80

Freewheel Elements

Cage Freewheels, Sprag Sets and Freewheel Chains.



Catalogue 89

Brakes

Industrial Disc Brakes

Manual actuated – manual release.



Catalogue 46

Industrial Disc Brakes

Spring actuated – pneumatical, hydraulic or manual release.



Catalogue 46

Industrial Disc Brakes

Spring actuated – electromagnetical release.



Catalogue 46

Industrial Disc Brakes

Pneumatical actuated – spring release.

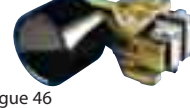

Catalogue 46

Industrial Disc Brakes

Hydraulic actuated – spring release.



Catalogue 46

Torque and Force Limiters

Torque Limiters with Screw Face

Reliable overload protection for tough operating conditions.



Catalogue 45

Torque Limiters with Rollers

With double or single Roller. Through ratcheting or disengaging, also for 360° synchronous running.



Catalogue 45

Torque Limiters with Spherical Rollers

Reliable overload protection with maximum response accuracy. Also backlash free.



Catalogue 45

Torque Limiters with Friction Linings

RIMOSTAT Torque Limiter for constant torque. Belleville Spring Torque Limiter for simple release.



Catalogue 45

Force Limiters

Reliable axial overload protection in piston rods.



Catalogue 49

Couplings and Clamping Clutches

Flexible Couplings

Large, allowed radial and angular misalignments. Minimum resiliency.



Catalogue 44

Flange-Couplings

Rigid, easily removable shaft coupling with no clearance cone clamping elements.



E04.020

HELICAL-Flexures Shaft Couplings

Design to meet requirements for specific applications. Connecting components can be integrated to save space.

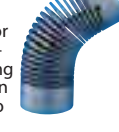

Catalogue 43

Clamping Clutches

For the automatic coupling of rolls. Fast, safe and free from slipping connection.



Catalogue 45

Fail-Safe Clamping Units

For secure and precise positioning of piston rods.



Catalogue 32

Shaft-Hub-Connections

Cone Clamping Elements

For shaft-hub connections. High torques with small dimensions.



Catalogue 31

Two-part Shrink Discs

External clamping connection. Advantages: Simple, secure mounting even without torque wrench.



Catalogue 31.1

Three-part Shrink Discs

External clamping connection for the fastening of hollow shafts on solid shafts



Catalogue 31

Star and Clamping Discs

Ideal for shaft-hub-connection for frequent release.



Catalogue 30

Star Spring Washers

Axial spring element for preloading of ball bearings.



Catalogue 20

Precision Clamping Fixtures

Standard Parts for Clamping Fixtures

The RINGSPANN-System for the manufacture of your own precision clamping fixtures.

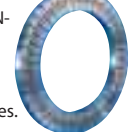

Catalogue 14

Standard Clamping Fixtures

Standard programme in high precision, ready manufactured chucks and mandrels.

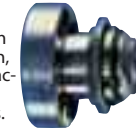

Catalogue 15

Special Clamping Fixtures

Custom made solutions for specific clamping problems.



Catalogue 16

Collet Mandrels

Universal, cost effective standard series. Fast collet change to other clamping diameters.



Catalogue 15

Hydraulic Expanding Clamping Tools

Mandrels and chucks with high concentricity. Clamping several workpieces in one process possible.



Catalogue 16

