

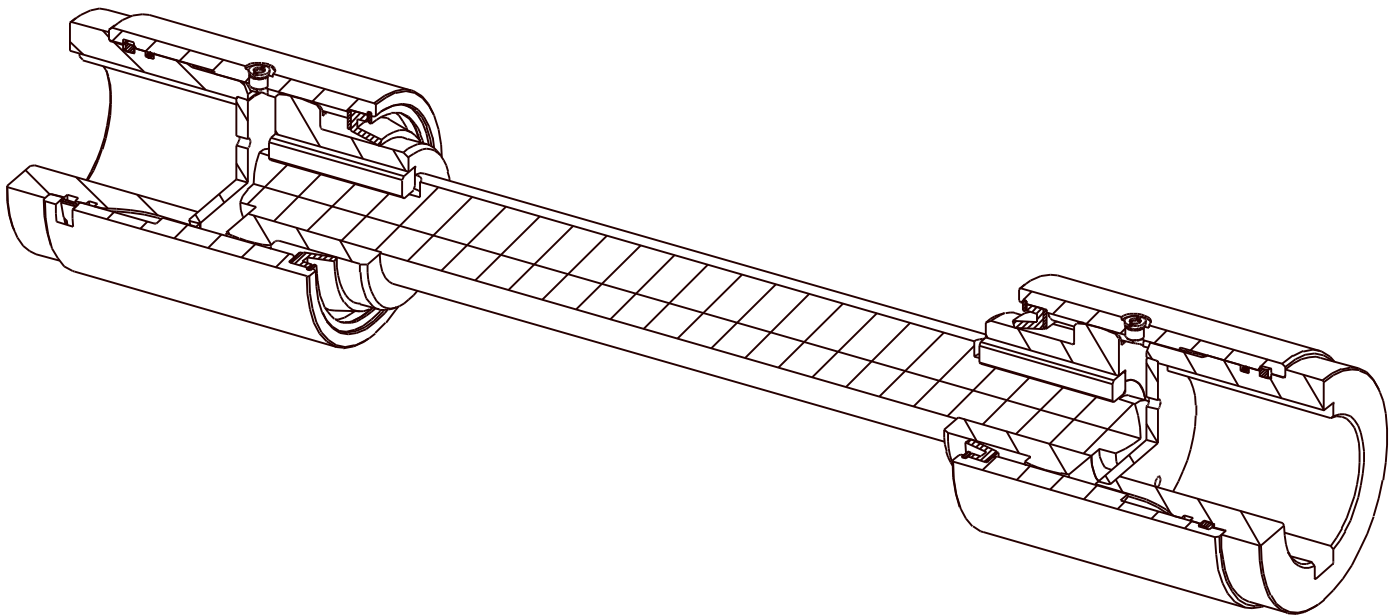

Amerigear[®] SL Spindle

Installation and Maintenance Manual



Ameridrives International
Coupling Products



Spindle Installation and Maintenance Manual

TABLE OF CONTENTS

SECTION	TITLE	PAGE
1	Introduction.....:	3
2	General Information.....:	3
3	Description of Terminology.....:	
3		
4	Pre-Installation Instructions.....:	4
5	Installation.....:	4
6	Spindle Lubrication.....:	6
7	Assembly Check.....:	7
8	General Maintenance.....:	8
9	Disassembly Procedure.....:	8
10	Ordering Information.....:	8

WARNING

ACCIDENTS INVOLVING ROTATING EQUIPMENT MAY RESULT IN LOSS OF LIFE, SERIOUS BODILY INJURY OR PROPERTY DAMAGE. THE PURCHASER OF THIS EQUIPMENT MUST ASSURE THAT THE EQUIPMENT IS PROPERLY ASSEMBLED, INSTALLED, SHIELDED, OPERATED AND MAINTAINED. THIS EQUIPMENT MUST NOT BE OPERATED AT CONDITIONS THAT EXCEED MANUFACTURER’S SPECIFICATIONS.

PURCHASER MUST FOLLOW ALL FEDERAL, STATE AND LOCAL LAWS AND REGULATIONS COVERING THE SAFE OPERATION AND MAINTENANCE OF THE EQUIPMENT, INCLUDING, WITHOUT LIMITATION, THE USDOL-OSHA “LOCKOUT/TAGOUT” PROCEDURE SET FORTH IN 29 CFR 1910.147.

IT IS THE PURCHASERS RESPONSIBILITY TO IMPLEMENT AND FOLLOW ITS OWN SAFETY, MAINTENANCE, AND EMPLOYEE TRAINING PROGRAM REGARDING THE SAFE AND PROPER OPERATION AND MAINTENANCE OF THE EQUIPMENT.

NOTE: THIS DOCUMENT SUPERSEDES IM4-006

1 INTRODUCTION

This Installation Manual is intended to be used as a guide for the installation and maintenance of Amerigear Flexible Spindles. For specific operating capacities and coupling data, refer to the Ameridrives Sales Drawing.

2 GENERAL INFORMATION

Ameridrives Amerigear SL series spindles are designed for use in mill applications. Amerigear spindles transmit torque while operating at specific misalignments between driving and driven equipment. The gear teeth are designed to accommodate both full load and no-load misalignments. The curvature on the flanks and the tips of external gear teeth allow the gear mesh to operate in a misaligned condition. The amount of curvature is varied in order to optimize performance under specific operating conditions. Refer to the applicable Ameridrives Sales Drawing for specific full load and no load capability. Clearance is provided between the ends of the intermediate shaft and the thrust plates for small deviations in the shaft separation or shaft growth due to thermal expansion.

This manual should be used as a guide for installation, lubrication, maintenance, and trouble shooting of Amerigear spindles. Spindle designs vary widely due to the specific requirements of each application. This manual covers the most common designs.

3 DESCRIPTION OF TERMINOLOGY

This section is intended to assist anyone not familiar with the terms used to describe the components of an Amerigear Flexible Spindle. Refer to Figure 3-1 to identify components and terms referred to in this manual. The figure shown depicts typical a spindle arrangement, refer to the applicable Ameridrives Sales Drawing for the specific design features and parts list.

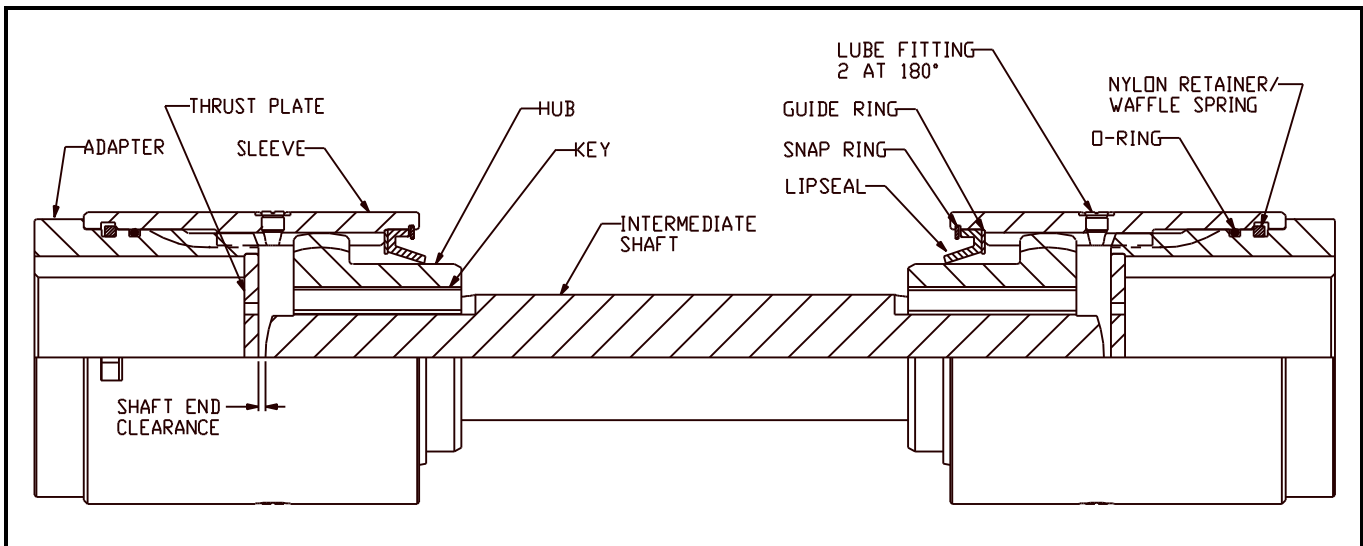

Figure 3-1
Typical Spindle Design

4 PRE-INSTALLATION INSTRUCTIONS

Refer to the referenced Ameridrives Sales Drawing to confirm specific set-up dimensions. Spindles are shipped completely assembled with critical exposed surfaces protected and coated with a preservative. At installation this coating should be removed with solvent.

If the assembly is to be stored for an extended period, do not remove the preservative. Be sure that the storage area is dry. If stored outdoors, the spindle assembly must be crated and protected from moisture at all times. Place supports under the unit to keep it off the ground.

When spindles are received:

- 4.1 Check for possible shipping damage or shortages.
- 4.2 Gear teeth are **NOT** fully lubricated at the factory and must be lubricated prior to operation.
- 4.3 When the hub and intermediate shaft are furnished with a spline connection, the spline will be lubricated at the factory. If the hub and shaft are disassembled, the spline must be cleaned relubricated before reassembling.
- 4.4 Partial disassembly is required for installation. See **INSTALLATION** Section 5.

5 INSTALLATION

Ameridrives Amerigear Flexible Spindle Assemblies are designed to give maximum performance for the required operating conditions specified on the Ameridrives Sales Drawing. Refer to the Sales Drawing for the actual distance between shaft ends requirement. The initial angular and parallel offset alignment of the equipment to be coupled should be set and secured so that the specified operating angle and parallel offset specified on the Sales Drawing are not exceeded. This will aid in assuring optimum life and performance of the spindle assembly.

The following is the recommended procedure for installation of a spindle assembly after alignment of the equipment is completed. This procedure is for an ideal situation where there are no obstructions to hinder installation.

- 5.1 Partial disassembly is usually required. Refer to the Ameridrives Sales Drawing prior to and during installation for parts identification and specific set-up dimensions.

CAUTION: AMERIDRIVES MANUFACTURED THE COUPLING INTERFACE BASED ON THE SHAFT DATA SUPPLIED BY THE PURCHASER. AMERIDRIVES IS NOT RESPONSIBLE FOR INACCURATE OR INCOMPLETE INFORMATION SUPPLIED BY THE PURCHASER. IT IS THE PURCHASERS RESPONSIBILITY TO ASSURE THAT THE INTERFACE CONNECTIONS (KEYS, HYDRAULIC FITS, ETC.) BETWEEN THE COUPLING AND THE CONNECTED EQUIPMENT ARE CAPABLE OF HANDLING ANTICIPATED LOADS.

- 5.1.1 Check bore, shaft diameter, and key(s) for proper fit. Verify that the engagement length between bore and shaft is correct.
- 5.1.2 Remove any nicks or dents with a fine grit stone.
- 5.1.3 Thoroughly clean and lubricate the equipment shafts.

- 5.1.4 With spindle assembly in a horizontal position and supported on the shaft, remove the nylon retainer or waffle spring from both sleeves. Remove the adapters and push the sleeves back onto the intermediate shaft assembly until clear of the hub gear teeth.
- 5.1.5 The adapter may be prepared for mounting by heating in oil or oven from 300°F to 350°F maximum. Higher temperatures should only be used if specified on the Sales Drawing.

CAUTION: DO NOT APPLY OPEN FLAME.

- 5.1.6 Apply lubricant sealing compound to key(s) and keyway(s) then assemble. Keys are typically installed flush with the shaft end.
- 5.1.7 Align the adapter and shaft keyway(s) and position the adapter as shown on the reference Ameridrives Sales Drawing.
- 5.1.8 When the adapters are cool, clean the o-ring groove, apply lubricant and re-install.
- 5.1.9 The spindle has been shipped with hubs mounted on the intermediate shaft and guide ring, lipseal, and snap ring mounted in each sleeve. Slide the sleeves onto the intermediate shaft assembly until clear of the hub gear teeth. Use care to avoid damage to the lipseal.
- 5.1.10 Clean all parts. Hand pack a generous amount of operating lubricant to each gear tooth of the mating parts. This avoids metal to metal contact at start up. Re-install sleeves on hubs.

NOTE: VERIFY THAT THE SNAP RING IS SEATED INTO GROOVE.

- 5.1.11 Push sleeves back on the hub to sufficiently expose the spherical shaft end.
- 5.1.12 Support shaft assembly and position it between the mounted adapters. Engage the sleeves on the adapters and secure with the nylon retainers or waffle springs **INSTALLED AGAINST THE DIRECTION OF ROTATION**. See Figures 5-1 through 5-3.

NOTE: MAKE SURE TAB OF NYLON RETAINER IS PUSHED DOWN INTO THE SLOT OF THE SLEEVE. (SEE FIGURE 5-2)

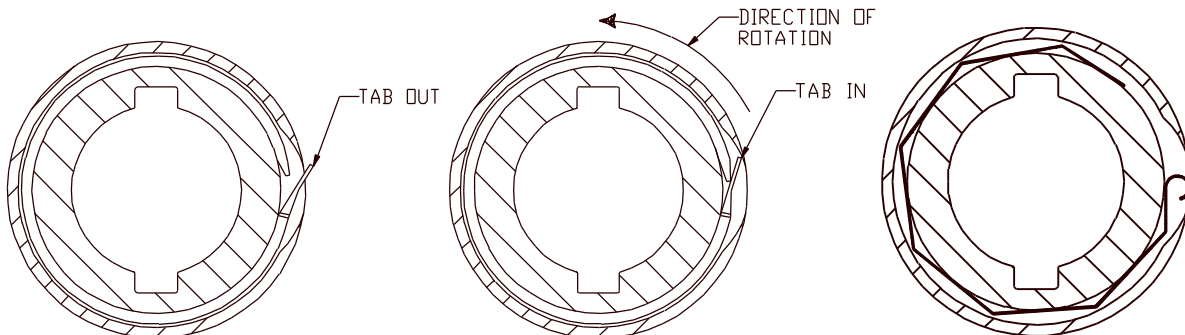

**Figure 5-1
Nylon Retainer
As Shipped**

**Figure 5-2
Nylon Retainer
Installed**

**Figure 5-3
Waffle Spring**

6 SPINDLE LUBRICATION

As previously stated, hub spline, intermediate shaft spline (if supplied), and o-ring seals are factory lubricated. If for any reason these components are disassembled, they are to be thoroughly cleaned and lubricated by hand. The use of operating lubricant for this purpose is recommended. Storage over an extended period of time or adverse conditions are reasons for disassembly, cleaning and relubricating.

A high quality lithium based or synthetic EP lubricant in compliance with AGMA 9001 for high torque operating conditions should be used. The following greases comply with AGMA 9001 for high torque operating conditions and have been used successfully with Ameridrives Spindles:

Mobilux EP-111 by Mobil Oil Co.
Anderol 786 by Huls America

For assistance in selecting lubricants from alternate suppliers please contact Ameridrives International.

CAUTION: TYPICALLY THE SPINDLES ARE PARTIALLY LUBED AT THE FACTORY WITH MOBILUX EP-111. THIS IS A LITHIUM BASED GREASE. OTHER TYPES OF GREASES MAY NOT BE COMPATIBLE. ALWAYS CONTACT THE LUBRICANT MANUFACTURER TO ASSURE COMPATIBILITY BEFORE USING DIFFERENT LUBRICANTS TO PREVENT PREMATURE FAILURE.

Gear teeth are **NOT** fully lubricated at the factory. All gear teeth should be cleaned and hand packed with spindle operating lubricant as described in Section 5.1.10. Unless otherwise specified, Ameridrives spindles are provided with two (2) equally spaced lube fittings in the adapters.

It is recommended that lubricant be checked at a minimum of **SIX** month intervals. General service, temperature, and operating conditions will best determine the required interval. To assure complete lubrication of each gear mesh, the following procedure should be followed.

6.1 Lubricating Spindle Gear Teeth

- 6.1.1 Provide a vent at about 12 o'clock position by inserting a small venting rod (**FREE OF BURRS**) between the hub barrel and the lip seal, see Figure 6-1.

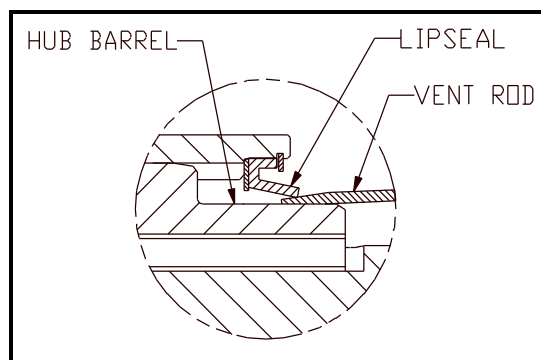

**Figure 6-1
Lipseal**

- 6.1.1 Locate one lube fitting below the horizontal centerline of the spindle. Pump the recommended amount of lubricant into the gear mesh cavity or until lube is noted at the vent rod or at any other portion of the lipseal inner diameter.

CAUTION: LUBRICATE BOTH GEAR MESHES.

6.1.2 Be sure all lube fittings are secured and remove vent rod.

7 ASSEMBLY CHECK

7.1 Prior To Initial Operation

7.1.1 Verify that the application requirements, including angular misalignment, and axial movement of the shaft assembly comply with the conditions specified on the applicable sales drawing.

7.1.2 Check that all lipseals are properly seated and the seal surface of the hubs are clean and free of burrs.

7.1.3 Check that the nylon retainers or the waffle springs and snap rings are properly seated.

7.1.4 Verify that each gear mesh is properly lubricated per Section 6.

7.1.5 Verify that all lube fittings are secure. **BE SURE VENTING ROD HAS BEEN REMOVED** from between the lip seal and hub barrel at both ends.

7.2 During Operation

7.2.1 Observe general alignment and operating conditions. Excessive vibration, noise and/or overheating generally indicates a problem. Shut down is recommended.

7.2.2 Inspect for evidence of lube leakage.

7.3 After Operation

7.3.1 Check the entire spindle after **ONE WEEK** of operation, to assure that no lube loss is occurring.

7.3.2 Check condition and quantity of lubricant at regular intervals during the first month of operation.

7.3.3 It is recommended that lubricant be checked at a minimum of **SIX** month intervals. Lubricant should be added to each gear mesh following the procedure in Section 6. General service, temperature, and operating conditions will best determine the required interval.

NOTE: COMPLIANCE WITH ALL APPLICABLE SAFETY CODES MUST BE OBSERVED AT ALL TIMES

8 GENERAL MAINTENANCE

On an annual basis, thoroughly clean and inspect for gear tooth wear, seal damage, wear of thrust plates, spherical shaft ends, or other abnormal conditions which will affect the performance and life of the spindle. The presence of any unusual vibration, noise and/or overheating during

operation or abnormal movement during the maintenance check should be thoroughly investigated to determine the cause. The possibility of loose nylon retainers, waffle springs or keys should be corrected if present.

Refer to Section 9 and reference Ameridrives Sales Drawing during disassembly and inspection.

Reassemble and lubricate the spindle in accordance with the instructions per Section 6.

- 8.1 Periodic inspection should be made to determine possible alignment changes. The misalignment capacity of the spindle should not be exceeded.
- 8.2 Check nylon retainers or waffle springs and snap rings for proper seating.
- 8.3 Inspect lipseals and seal surfaces. Prevent damage to lipseals and possible lube loss by maintaining a clean and smooth seal surface.
- 8.4 Establish a schedule for clean-out and relubrication of the each gear mesh. When relubrication is required, refer to Section 6 and pertinent assembly instructions.

9 DISASSEMBLY PROCEDURE

Refer to the Ameridrives Sales Drawing and Figure 3-1 for parts identification and relative position in the assembly. Partial disassembly is required for spindle installation and removal.

Support the spindle components as required during disassembly and assembly. Remove the nylon retainers or waffle springs and push the sleeves back on the hub to sufficiently expose the spherical shaft end. Remove spindle and inspect per Section 8. **DO NOT** permit the intermediate shaft assembly to rest on hub gear teeth. Protect all parts from damage. Lip seals will require extra care in handling to prevent damage.

10 ORDERING INFORMATION

When returning a spindle for overhaul or to order replacement parts, please contact our Mill Products Group at ***our new address or call us at our new phone listed below, our fax remains the same:***

***Ameridrives International
Coupling Products***

P.O. Box 4000
1802 Pittsburgh Ave.
Erie, Pennsylvania USA 16512-4000
Phone: 814/480-5000
Fax: 814/453-5891

Please provide the following information:

Size and type of Spindle.
Ameridrives sales drawing number.
Part number, name and quantity of each part.