



# MGS™ Speed Reducers

## Safety Instructions

In order to obtain long life and trouble-free operation from your MGS speed reducer, it is essential that the proper installation and operating procedures be followed. Failure to follow these instructions will void the drive's warranty.

The torque required by the application must not exceed the reducer torque capacity shown on the nameplate. For safety purposes, a safety coupling should be installed between the reducer and the driven load. Otherwise, overload may cause damage to the interior parts of the reducer which may result in breaking the reducer housing. As a result, persons could be injured by flying parts or splashing hot gear oil.

If you have questions about the installation, operation or maintenance of your MGS unit, please contact your local STOBER distributor or STOBER Technical Support for assistance.

**WARNING:** Safety is the most important consideration when operating any type of drive. Through proper application, safe handling methods, and wearing appropriate clothing, you can prevent accidents and injury to yourself and fellow workers.



The shafts of MGS speed reducers rotate at very high speeds and can cut off or severely injure hands, fingers, and arms. Use appropriate guards for shafts and other rotating parts at all times. Follow all directions in the service instruction manual. Obey all federal, state and local safety regulations when operating the drive.

- Always be sure electrical power is off while making electrical connections and during installation and maintenance of the unit.
- Keep clothing, hands, and tools away from ventilation openings on motors and from all rotating parts during operation.
- Lift the drive with a double rope sling or other proper lifting equipment of adequate strength. Make sure load is secured and balanced to prevent shifting when unit is being moved. Lifting drives by hand may be dangerous and should be avoided.
- The intended use of lifting lugs is to handle the weight of the unit only. Never use a lifting lug to lift attached assemblies.
- Never operate drive at speeds higher than those shown on the nameplate, or personal injury may result. Contact STOBER Drives Inc., if there is any change of operating conditions from those for which the unit was originally sold (as stamped on the nameplate). Failure to comply could result in personal injury and or machinery damage.
- Always follow good safety practices at all times.

Each drive is tested before delivery. Before installation, however, it is advisable to examine the unit for possible damage which might have occurred during transit. If damage is discovered, it should be immediately reported to the transport agent.









If installation is delayed after receipt of the MGS speed reducer, the drive should be stored in a clean, dry place until put into service. Long term storage requires special procedures. If not kept in a heated, dry area, consult STOBER Drives, Inc. for storage instructions.

**NOTE:** If it is necessary to clean drive shafts, take care to protect the oil seals.

**IMPORTANT:** Do not use any device to hammer the unit onto the output shaft during installation since the bearing races could be damaged.

Maintenance and lubrication information can be found beginning on Page 180 of this catalog.

## Table of Contents

	<b>Supreme Food Duty – "KE" Series</b>	
	Dimensions .....	7
	<b>Food Duty – "K, "F" and "C" Series</b>	
	Overview – "K" Series .....	14
	Overview – "F" Series .....	30
	Overview – "C" Series .....	34
	<b>Beverage Duty – "K and C" Series</b>	
	Overview – "K" Series .....	42
	Overview – "C" Series .....	54
	<b>"C" Series – Concentric Helical</b>	
	Overview .....	63
	Selection Data .....	64
	Dimension Pages .....	92
	Optional Output Flanges .....	95
	<b>"F" Series – Offset Helical</b>	
	Overview .....	101
	Selection Data .....	102
	Dimension Pages .....	110
	Torque Arm Mounting .....	111
	WF Bushings .....	112
	<b>"K" Series – Right Angle Helical/Bevel</b>	
	Overview .....	115
	Selection Data .....	116
	Dimension Pages .....	140
	Optional Output Flanges .....	142
	Wobble Free Bushings .....	148
	Torque Arm Bracket .....	152
	<b>"S" Series – Right Angle Helical/Worm</b>	
	Overview .....	155
	Selection Data .....	156
	Dimension Pages .....	162
	Optional Output Flanges .....	163
	Torque Arm Bracket .....	165
	<b>Miscellaneous</b>	
	Adjustable Speed Drives .....	167
	AW Input Shaft Dimensions .....	170
	Installation of Hollow Output .....	171
	Backstops and Direction of Rotation ...	172
	Motor Installation Instructions .....	174
	Wobble Free Bushing Installation .....	176
	"KE" Installation Instructions .....	178
	Lubrication and Mounting Data .....	180
	Maintenance and Tolerance Data .....	181
	Service Factor/Selection Procedure ....	182
	Terms and Conditions of Sale .....	184
		

# MGS™ Speed Reducers

## The STÖBER difference = VALUE for you!



### Engineered – Structural Rigidity



### Engineered – Precision Gearing Process



- blanked
- turned
- rough milled
- case hardened (61 RC)
- grinding
  - bearing seat
  - pinion outside diameter



## 3 and 5 YEAR WARRANTY



### Engineered – High Quality Bearings

Tight Tolerance – Reduced Clearance  
Crowned cage for optimal lubricant flow

- improved ball guidance
- fast lubrication film formation
- reduced friction
- lower running noise
- eliminates cage ejections



### Attention to Detail – Robustness

- NEMA C-face adapter with O-ring
- dual output seals
- flexible coupling eliminates misalignment, motor easily removed
- long-life input seals
- stainless steel oil plugs
- magnetic drain plugs
- gears supported with dual bearings in one-piece housing for structural rigidity





# MGS™ Speed Reducers

## Reliability, Adaptability, Maintainability

**3 WAY**  
After Sale Service  
5 Day Factory Service  
Field Service  
Training Support

**STANDARD**  
**3-DAY**  
**DELIVERY**

**SAME DAY**  
**EMERGENCY**  
**SHIPPING**

**3 Rings**  
To get competent,  
"one-stop" shopping!

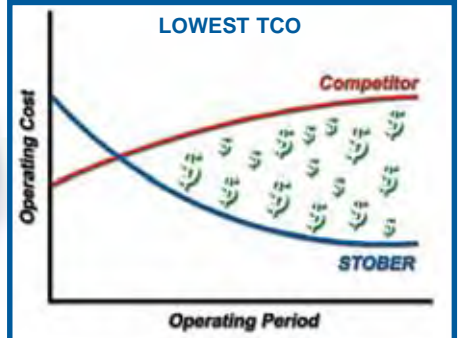

### Energy Efficiency

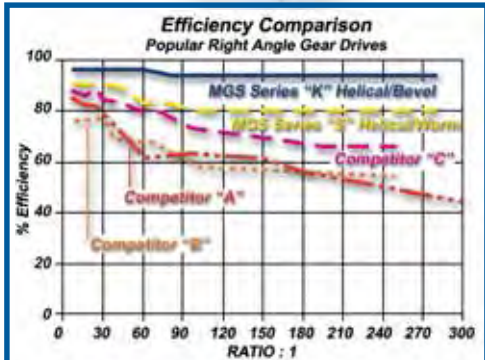

# MGS™ Speed Reducers 3 Year Warranty – Standard



## ***Standard Warranty Includes:***

- Standard Mineral Oil**
- Application Specific Mounting Position - 6 Choices**  
(Food and Beverage Units are ANY Horizontal Output)
- Choice of 4 Coatings**
- Maintenance Free**





# MGS™ Speed Reducers 5 Year Warranty – Long Life



**5 YEAR WARRANTY**  
*includes bearings and seals*



## ***Long Life Warranty Includes:***

- Improved Input
- Synthetic Oil
- Application Specific Mounting Position - 3 Choices
- Choice of 4 Coatings
- Maintenance Free





# Food and Beverage Duty Speed Reducers

3 YEAR WARRANTY STANDARD



5 YEAR WARRANTY OPTIONAL



3-DAY  
DELIVERY



[www.stober.com](http://www.stober.com)

# Supreme Food Duty – "KE" Series MGS Reducers Right Angle Helical/Bevel with Double Bushing



STOBER Drives Inc. is proud to introduce the newly engineered Supreme Food Duty speed reducer. Drawing on the proven high efficiency gearing of the MGS line, then packaging that efficiency into a specialized housing, this new unit is optimized for the harsh environments of the food industry. The features shown below meet the criteria set forth by the American food industry like no other unit available today.

### Performance Specifications:

- Up to 5 HP
- Output Bore Diameters up to 1½ inch
- Ratios up to 70:1
- NEMA C-face for 56C through 182/184TC
- Maintenance free – Lubricated for Life
- Cleanable to a microbiological level
- All units feature Silver Bullet Anti-Microbial™ coating



Integral torque arm bracket for universal mounting

Made to food industry compatible materials specifications –  
NO harborage points  
NO niches  
NO product or liquid collections



Uses the patented (U.S. Patent Number 5,496,127) Stainless Steel Double Sided Bushing Mounted into Stainless Steel Output Quill – easily installs onto standard cold finished, ground, or stainless shafting

Provided with sealed output covers

Mounts in any horizontal output position without changing oil level  
Shipped filled with Mobile SHC630

### Part No. Explanation

**KE 4 0 2 W B 0100 MR160/140 F -108**

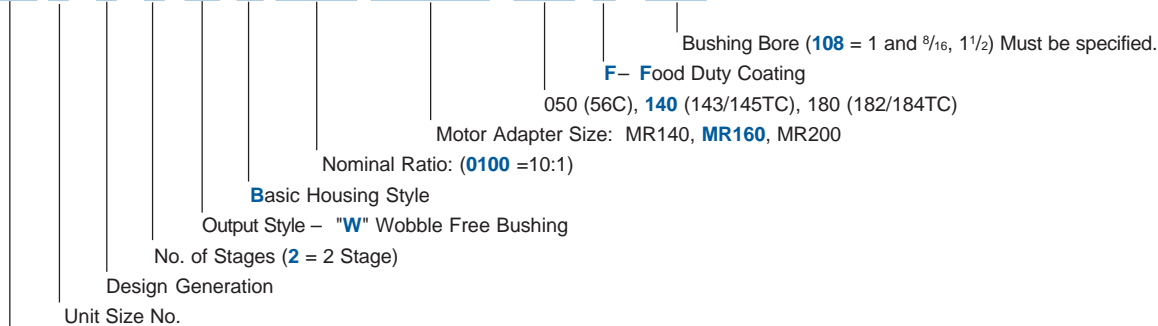





# Supreme Food Duty – "KE" Series Basic Unit – "B" Housing Double Bushing – Dimensional Data

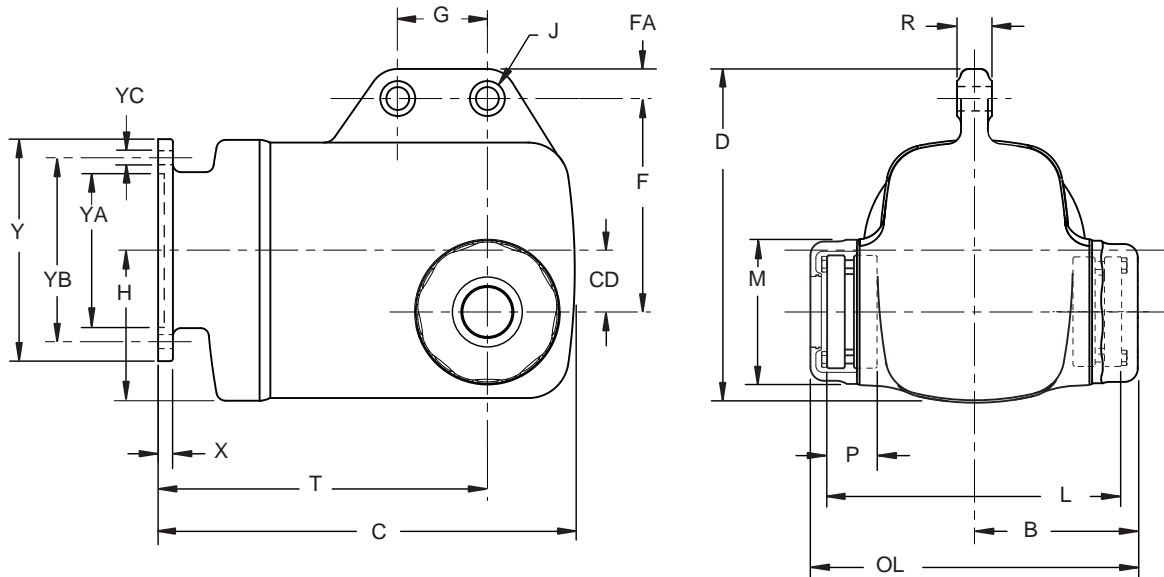
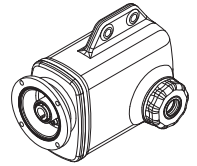

Drawing for Units  
KE202WB — KE402WB

Table No. 1 "KE" Series – Double Wobble Free Bushing – Unit Dimensions (Inches)

Unit Number	B	D	F	G	H	J	L	M	P	R	CD	FA	OL
KE2	4.78	9.72	6.25	2.625	4.41	.67	8.62	4.17	1.46	1.02	1.77	.87	9.57
KE3	5.02	10.75	6.75	3.000	5.06	.67	9.09	4.17	1.46	1.02	2.07	.96	10.04
KE4	5.77	12.17	7.44	3.500	5.89	.83	10.67	4.76	1.69	1.22	2.36	1.18	11.54

Table No. 2 "KE" Series Dimensions (Inches)

Unit with Motor Adapter	NEMA C-Flange	C	T	X	Y	YA	YB	YC	Wt. lbs.
KE202WB_MR160/050F	56C	12.20	9.65	.43	6.50	4.500	5.87	.41	53
KE202WB_MR160/140F	143/145TC	12.20	9.65	.43	6.50	4.500	5.87	.41	53
KE302WB_MR160/050F	56C	13.38	10.43	.43	6.50	4.500	5.87	.41	63.5
KE302WB_MR160/140F	143/145TC	13.38	10.43	.43	6.50	4.500	5.87	.41	63.5
KE402WB_MR160/050F	56C	14.76	11.22	.43	6.50	4.500	5.87	.41	94
KE402WB_MR160/140F	143/145TC	14.76	11.22	.43	6.50	4.500	5.87	.41	94
KE402WB_MR200/180F	182/184TC	15.75	12.20	.51	9.00	8.500	7.25	.55	99

Table No. 3 "WFKE" Double Side Bushings

Unit	Stock Bores Sizes					
	1	1 <sup>3</sup> / <sub>16</sub>	1 <sup>1</sup> / <sub>4</sub>	1 <sup>3</sup> / <sub>8</sub>	1 <sup>7</sup> / <sub>16</sub>	1 <sup>1</sup> / <sub>2</sub>
KE2	WFKE2-100	WFKE2-103	WFKE2-104	WFKE2-106	WFKE2-107	WFKE2-108
KE3	WFKE3-100	WFKE3-103	WFKE3-104	WFKE3-106	WFKE3-107	WFKE3-108
KE4	WFKE4-100	WFKE4-103	WFKE4-104	WFKE4-106	WFKE4-107	WFKE4-108

### Bushing Part No. Explanation

**WFKE 4 - 107**

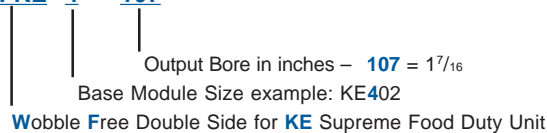



# Supreme Food Duty – "KE" Series MGS Reducer – Selection Data



## Selection Procedure:

- Under the Input RPM heading, find **Approximate Output RPM** nearest the requirement.
- In the **Input HP** column locate the rating that is greater than or equal to the required HP.  
(If selection is based on Torque instead of HP, find an **Output Torque** that is equal to or greater than required.)
- When HP or Torque rating is located, read across that row to select the **Part Number, Input Option and Overhung Loads**.
- If exact **Output RPM** is required, divide the **Input RPM** by the **Exact Ratio**.

1750 RPM Input		Part Number <sup>1)</sup>		NEMA C-Frame	Exact Ratio	Approximate Overhung Load <sup>2)</sup> lbs.	1450 RPM Input		1160 RPM Input		870 RPM Input	
Input HP	Output Torque in. lbs.	Base Module	Motor Adapter				Input HP	Output Torque in. lbs.	Input HP	Output Torque in. lbs.	Input HP	Output Torque in. lbs.
<b>430 RPM Output (Approximate)</b>												
6.84*	956	KE202WB0040	MR160/050F	56C	4.000	312	5.98*	1,023	5.20	1,097	4.29	1,207
6.84*	956	KE202WB0040	MR160/140F	143/145TC	4.000	312	5.98*	1,023	5.20	1,097	4.29	1,207
12.0*	1,675	KE302WB0040	MR160/050F	56C	4.000	468	10.5*	1,792	9.10*	1,921	7.51*	2,114
12.0*	1,675	KE302WB0040	MR160/140F	143/145TC	4.000	468	10.5*	1,792	9.10*	1,921	7.51*	2,114
16.6*	2,318	KE402WB0040	MR160/050F	56C	4.000	583	13.5*	2,318	11.00	2,318	8.24	2,318
16.6*	2,318	KE402WB0040	MR160/140F	143/145TC	4.000	583	13.5*	2,318	11.00	2,318	8.24	2,318
18.0*	2,513	KE402WB0040	MR200/180F	182/184TC	4.000	583	15.7*	2,689	13.7*	2,883	11.30	3,173
<b>400 RPM Output (Approximate)</b>												
6.45*	984	KE202WB0044	MR160/050F	56C	4.364	318	5.64*	1,053	4.90	1,129	4.05	1,243
6.45*	984	KE202WB0044	MR160/140F	143/145TC	4.364	318	5.64*	1,053	4.90	1,129	4.05	1,243
11.3*	1,724	KE302WB0044	MR160/050F	56C	4.364	478	9.87*	1,844	8.59*	1,978	7.09	2,177
11.3*	1,724	KE302WB0044	MR160/140F	143/145TC	4.364	478	9.87*	1,844	8.59*	1,978	7.09	2,177
16.4*	2,501	KE402WB0044	MR160/050F	56C	4.364	595	13.4*	2,501	10.90	2,501	8.15	2,501
16.4*	2,501	KE402WB0044	MR160/140F	143/145TC	4.364	595	13.4*	2,501	10.90	2,501	8.15	2,501
17.0*	2,587	KE402WB0044	MR200/180F	182/184TC	4.364	595	14.8*	2,768	12.9*	2,968	10.60	3,267
<b>335 RPM Output (Approximate)</b>												
5.76*	1,042	KE202WB0052	MR160/050F	56C	5.177	332	5.03	1,115	4.23	1,155	3.17	1,155
5.76*	1,042	KE202WB0052	MR160/140F	143/145TC	5.177	332	5.03	1,115	4.23	1,155	3.17	1,155
<b>325 RPM Output (Approximate)</b>												
9.79*	1,848	KE302WB0054	MR160/050F	56C	5.375	504	8.56*	1,977	7.44*	2,120	6.14	2,333
9.79*	1,848	KE302WB0054	MR160/140F	143/145TC	5.375	504	8.56*	1,977	7.44*	2,120	6.14	2,333
14.7*	2,782	KE402WB0054	MR160/050F	56C	5.422	627	12.9*	2,976	10.60	3,030	7.98	3,030
14.7*	2,782	KE402WB0054	MR160/140F	143/145TC	5.422	627	12.9*	2,976	10.60	3,030	7.98	3,030
14.7*	2,782	KE402WB0054	MR200/180F	182/184TC	5.422	627	12.9*	2,976	10.60	3,030	7.98	3,030
<b>300 RPM Output (Approximate)</b>												
5.22	1,095	KE202WB0060	MR160/050F	56C	6.000	345	4.56	1,172	3.97	1,256	3.24	1,369
5.22	1,095	KE202WB0060	MR160/140F	143/145TC	6.000	345	4.56	1,172	3.97	1,256	3.28	1,383
9.14*	1,917	KE302WB0060	MR160/050F	56C	6.000	518	7.99*	2,051	6.95	2,199	5.73	2,421
9.14*	1,917	KE302WB0060	MR160/140F	143/145TC	6.000	518	7.99*	2,051	6.95	2,199	5.73	2,421
13.70*	2,878	KE402WB0060	MR160/050F	56C	6.000	644	12.00	3,078	10.40	3,301	8.15	3,440
13.70*	2,878	KE402WB0060	MR160/140F	143/145TC	6.000	644	12.00	3,078	10.40	3,301	8.15	3,440
13.70*	2,878	KE402WB0060	MR200/180F	182/184TC	6.000	644	12.00	3,078	10.40	3,301	8.61	3,633

\* For thermal HP capacity, see rating below.

Base Module	KE2	KE3	KE4
Thermal Capacity	5.36	7.38	12.34

NEMA Frame Size TEFC 1750 RPM	
C-Frame	Motor HP
56C	1/3 - 1 1/2
143/145TC	1, 1 1/2, 2
182/184TC	3, 5

## Part No. Explanation

KE 4 0 2 W B 0100 MR160 / 140 F - 108

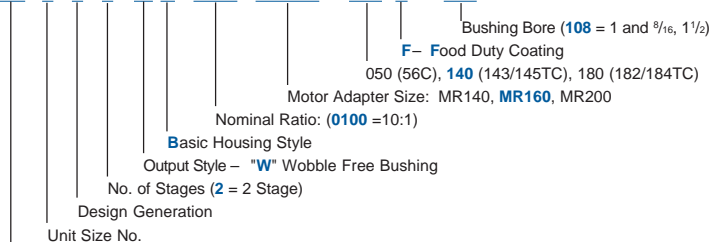

"K" Right Angle Helical/Bevel Supreme Food Duty





# Supreme Food Duty – "KE" Series MGS Reducer – Selection Data



**NOTE:** <sup>1)</sup> All KE units include the bushing. Complete the Part Number by adding the Bushing Bore Size. KE units will NOT be shipped unless the Bushing Bore is specified. Bushing Kits may be ordered separately to change the bore size.  
<sup>2)</sup> Hollow output units are not intended to support overhung loads. Use the load shown only as a reference.

1750 RPM Input		Part Number <sup>1)</sup>		NEMA C-Frame	Exact Ratio	Approximate Overhung Load <sup>2)</sup> lbs.	1450 RPM Input		1160 RPM Input		870 RPM Input	
Input HP	Output Torque in. lbs.	Base Module	Motor Adapter				Input HP	Output Torque in. lbs.	Input HP	Output Torque in. lbs.	Input HP	Output Torque in. lbs.
<b>260 RPM Output (Approximate)</b>												
							<b>215 RPM</b>	<b>175 RPM</b>	<b>130 RPM</b>			
4.84	1,134	KE202WB0067	MR160/050F	56C	6.683	355	4.23	1,214	3.68	1,301	3.04	1,432
4.84	1,134	KE202WB0067	MR160/140F	143/145TC	6.683	355	4.23	1,214	3.68	1,301	3.04	1,432
8.50*	1,993	KE302WB0067	MR160/050F	56C	6.740	532	7.43*	2,132	6.46	2,286	5.33	2,516
8.50*	1,993	KE302WB0067	MR160/140F	143/145TC	6.740	532	7.43*	2,132	6.46	2,286	5.33	2,516
12.7*	2,988	KE402WB0067	MR160/050F	56C	6.719	612	11.10	3,196	9.69	3,427	7.68	3,624
12.7*	2,988	KE402WB0067	MR160/140F	143/145TC	6.719	612	11.10	3,196	9.69	3,427	7.68	3,624
12.7*	2,988	KE402WB0067	MR200/180F	182/184TC	6.719	612	11.10	3,196	9.69	3,427	8.00	3,772
<b>235 RPM Output (Approximate)</b>												
							<b>195 RPM</b>	<b>160 RPM</b>	<b>120 RPM</b>			
4.66	1,159	KE202WB0071	MR160/050F	56C	7.118	360	4.07	1,240	3.54	1,330	2.92	1,464
4.66	1,159	KE202WB0071	MR160/140F	143/145TC	7.118	360	4.07	1,240	3.54	1,330	2.92	1,464
7.91*	2,055	KE302WB0074	MR160/050F	182/184TC	7.391	546	6.92	2,199	6.02	2,358	4.97	2,595
7.91*	2,055	KE302WB0074	MR160/140F	182/184TC	7.391	546	6.92	2,199	6.02	2,358	4.97	2,595
11.90	3,093	KE402WB0075	MR160/050F	56C	7.456	680	10.40	3,309	9.02	3,548	7.44	3,905
11.90	3,093	KE402WB0075	MR160/140F	143/145TC	7.456	680	10.40	3,309	9.02	3,548	7.44	3,905
11.90	3,093	KE402WB0075	MR200/180F	182/184TC	7.456	680	10.40	3,309	9.02	3,548	7.44	3,905
<b>210 RPM Output (Approximate)</b>												
							<b>170 RPM</b>	<b>140 RPM</b>	<b>105 RPM</b>			
4.17	1,224	KE202WB0084	MR160/050F	56C	8.397	375	3.65	1,310	3.17	1,404	2.62	1,546
4.17	1,224	KE202WB0084	MR160/140F	143/145TC	8.397	375	3.65	1,310	3.17	1,404	2.62	1,546
7.32	2,148	KE302WB0084	MR160/050F	56C	8.444	563	6.40	2,298	5.56	2,464	4.59	2,712
7.32	2,148	KE302WB0084	MR160/140F	143/145TC	8.444	563	6.40	2,298	5.56	2,464	4.59	2,712
11.00	3,216	KE402WB0084	MR160/050F	56C	8.377	701	9.58	3,440	8.33	3,688	6.88	4,060
11.00	3,216	KE402WB0084	MR160/140F	143/145TC	8.377	701	9.58	3,440	8.33	3,688	6.88	4,060
11.00	3,216	KE402WB0084	MR200/180F	182/184TC	8.377	701	9.58	3,440	8.33	3,688	6.88	4,060
<b>190 RPM Output (Approximate)</b>												
							<b>155 RPM</b>	<b>125 RPM</b>	<b>95 RPM</b>			
3.92	1,262	KE202WB0092	MR160/050F	56C	9.190	384	3.43	1,350	2.98	1,448	2.46	1,593
3.92	1,262	KE202WB0092	MR160/140F	143/145TC	9.190	384	3.43	1,350	2.98	1,448	2.46	1,593
6.83	2,216	KE302WB0093	MR160/050F	56C	9.267	577	5.97	2,371	5.20	2,543	4.29	2,798
6.83	2,216	KE302WB0093	MR160/140F	143/145TC	9.267	577	5.97	2,371	5.20	2,543	4.29	2,798
10.30	3,322	KE402WB0092	MR160/050F	56C	9.238	717	9.02	3,554	7.84	3,811	6.47	4,195
10.30	3,322	KE402WB0092	MR160/140F	143/145TC	9.238	717	9.02	3,554	7.84	3,811	6.47	4,195
10.30	3,322	KE402WB0092	MR200/180F	182/184TC	9.238	717	9.02	3,554	7.84	3,811	6.47	4,195

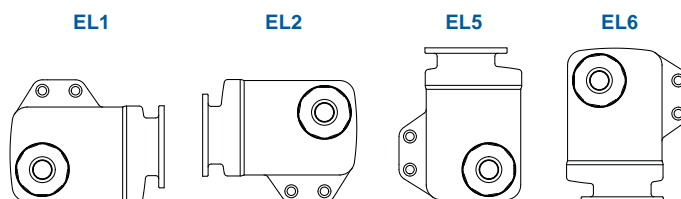

**Mounts in ANY Horizontal Output**



# Supreme Food Duty – "KE" Series MGS Reducer – Selection Data



## Selection Procedure:

- Under the Input RPM heading, find **Approximate Output RPM** nearest the requirement.
- In the **Input HP** column locate the rating that is greater than or equal to the required HP.  
(If selection is based on Torque instead of HP, find an **Output Torque** that is equal to or greater than required.)
- When HP or Torque rating is located, read across that row to select the **Part Number, Input Option and Overhung Loads**.
- If exact **Output RPM** is required, divide the **Input RPM** by the **Exact Ratio**.

1750 RPM Input		Part Number <sup>1)</sup>		NEMA C-Frame	Exact Ratio	Approximate Overhung Load <sup>2)</sup> lbs.	1450 RPM Input		1160 RPM Input		870 RPM Input	
Input HP	Output Torque in. lbs.	Base Module	Motor Adapter				Input HP	Output Torque in. lbs.	Input HP	Output Torque in. lbs.	Input HP	Output Torque in. lbs.
<b>170 RPM Output (Approximate)</b>												
							<b>140 RPM</b>	<b>115 RPM</b>	<b>85 RPM</b>			
3.68	1,301	KE202WB0100	MR160/050F	56C	10.07	393	3.22	1,392	2.80	1,493	2.31	1,643
3.68	1,301	KE202WB0100	MR160/140F	143/145TC	10.07	393	3.22	1,392	2.80	1,493	2.31	1,643
6.46	2,283	KE302WB0100	MR160/050F	56C	10.14	590	5.64	2,443	4.91	2,619	4.05	2,883
6.46	2,283	KE302WB0100	MR160/140F	143/145TC	10.14	590	5.64	2,443	4.91	2,619	4.05	2,883
9.68	3,423	KE402WB0100	MR160/050F	56C	10.10	734	8.46	3,662	7.36	3,926	6.07	4,321
9.68	3,423	KE402WB0100	MR160/140F	143/145TC	10.10	734	8.46	3,662	7.36	3,926	6.07	4,321
9.68	3,423	KE402WB0100	MR200/180F	182/184TC	10.10	734	8.46	3,662	7.36	3,926	6.07	4,321
<b>150 RPM Output (Approximate)</b>												
							<b>125 RPM</b>	<b>100 RPM</b>	<b>75 RPM</b>			
3.37	1,361	KE202WB0115	MR160/050F	56C	11.55	406	2.95	1,457	2.56	1,562	2.12	1,719
3.37	1,361	KE202WB0115	MR160/140F	143/145TC	11.55	406	2.95	1,457	2.56	1,562	2.12	1,719
5.92	2,389	KE302WB0115	MR160/050F	56C	11.61	610	5.04	2,493	4.09	2,493	3.07	2,493
5.92	2,389	KE302WB0115	MR160/140F	143/145TC	11.61	610	5.17	2,556	4.50	2,741	3.71	3,016
8.85	3,576	KE402WB0115	MR160/050F	56C	11.52	759	7.74	3,825	6.73	4,102	5.56	4,514
8.85	3,576	KE402WB0115	MR160/140F	143/145TC	11.52	759	7.74	3,825	6.73	4,102	5.56	4,514
8.85	3,576	KE402WB0115	MR200/180F	182/184TC	11.52	759	7.74	3,825	6.73	4,102	5.56	4,514
<b>140 RPM Output (Approximate)</b>												
							<b>115 RPM</b>	<b>92 RPM</b>	<b>70 RPM</b>			
3.19	1,406	KE202WB0125	MR160/050F	56C	12.70	415	2.78	1,504	2.42	1,613	2.00	1,772
3.19	1,406	KE202WB0125	MR160/140F	143/145TC	12.70	415	2.78	1,504	2.42	1,613	2.00	1,772
5.56	2,454	KE302WB0125	MR160/050F	56C	12.58	623	4.64	2,508	3.77	2,508	2.82	2,508
5.56	2,454	KE302WB0125	MR160/140F	143/145TC	12.58	623	4.86	2,625	4.23	2,815	3.49	3,098
8.36	3,690	KE402WB0125	MR160/050F	56C	12.66	776	7.31	3,947	6.36	4,233	5.25	4,659
8.36	3,690	KE402WB0125	MR160/140F	143/145TC	12.66	776	7.31	3,947	6.36	4,233	5.25	4,659
8.36	3,690	KE402WB0125	MR200/180F	182/184TC	12.66	776	7.31	3,947	6.36	4,233	5.25	4,659
<b>125 RPM Output (Approximate)</b>												
							<b>100 RPM</b>	<b>85 RPM</b>	<b>62 RPM</b>			
2.96	1,447	KE202WB0140	MR160/050F	56C	13.85	426	2.59	1,548	2.25	1,660	1.80	1,772
2.96	1,447	KE202WB0140	MR160/140F	143/145TC	13.85	426	2.59	1,548	2.25	1,660	1.80	1,772
5.20	2,540	KE302WB0140	MR160/050F	56C	13.94	639	4.55	2,717	3.92	2,889	2.94	2,889
5.20	2,540	KE302WB0140	MR160/140F	143/145TC	13.94	639	4.55	2,717	3.96	2,913	3.16	3,100
7.80	3,806	KE402WB0140	MR160/050F	56C	13.89	796	6.82	4,071	5.93	4,366	4.89	4,805
7.80	3,806	KE402WB0140	MR160/140F	143/145TC	13.89	796	6.82	4,071	5.93	4,366	4.89	4,805
7.80	3,806	KE402WB0140	MR200/180F	182/184TC	13.89	796	6.82	4,071	5.93	4,366	4.89	4,805

\* For thermal HP capacity, see rating below.

Base Module	KE2	KE3	KE4
Thermal Capacity	5.36	7.38	12.34

NEMA Frame Size TEFC 1750 RPM	
C-Frame	Motor HP
56C	1/3 - 1 1/2
143/145TC	1, 1 1/2, 2
182/184TC	3, 5

## Part No. Explanation

KE 4 0 2 W B 0100 MR160 / 140 F - 108

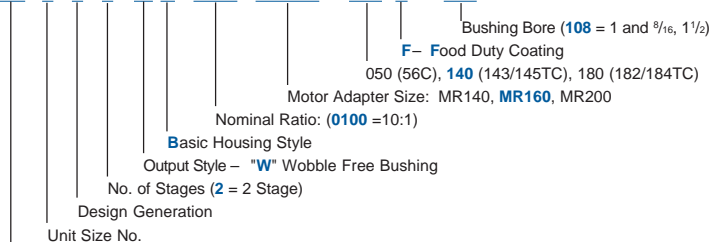

"K" Right Angle Helical/Bevel Supreme Food Duty



# Supreme Food Duty – "KE" Series MGS Reducer – Selection Data



- NOTE:** <sup>1)</sup> All KE units include the bushing. Complete the Part Number by adding the Bushing Bore Size. KE units will NOT be shipped unless the Bushing Bore is specified. Bushing Kits may be ordered separately to change the bore size.
- <sup>2)</sup> Hollow output units are not intended to support overhung loads. Use the load shown only as a reference.

1750 RPM Input		Part Number <sup>1)</sup>		NEMA C-Frame	Exact Ratio	Approximate Overhung Load <sup>2)</sup> lbs.	1450 RPM Input		1160 RPM Input		870 RPM Input	
Input HP	Output Torque in. lbs.	Base Module	Motor Adapter				Input HP	Output Torque in. lbs.	Input HP	Output Torque in. lbs.	Input HP	Output Torque in. lbs.
<b>105 RPM Output (Approximate)</b>							<b>85 RPM</b>	<b>70 RPM</b>	<b>53 RPM</b>			
2.61	1,545	KE202WB0170	MR160/050F	56C	16.86	447	2.28	1,653	1.98	1,772	1.49	1,772
2.61	1,545	KE202WB0170	MR160/140F	143/145TC	16.86	447	2.28	1,653	1.98	1,772	1.49	1,772
4.57	2,710	KE302WB0170	MR160/050F	56C	16.94	671	4.00	2,899	3.47	3,100	2.60	3,100
4.57	2,710	KE302WB0170	MR160/140F	143/145TC	16.94	671	4.00	2,899	3.47	3,100	2.60	3,100
6.86	4,067	KE402WB0170	MR160/050F	56C	16.94	835	6.00	4,350	5.22	4,665	4.09	4,872
6.86	4,067	KE402WB0170	MR160/140F	143/145TC	16.94	835	6.00	4,350	5.22	4,665	4.09	4,872
6.86	4,067	KE402WB0170	MR200/180F	182/184TC	16.94	835	6.00	4,350	5.22	4,665	4.09	4,872
<b>100 RPM Output (Approximate)</b>							<b>82 RPM</b>	<b>65 RPM</b>	<b>50 RPM</b>			
2.56	1,563	KE202WB0175	MR160/050F	56C	17.47	450	2.24	1,672	1.93	1,772	1.44	1,772
2.56	1,563	KE202WB0175	MR160/140F	143/145TC	17.47	450	2.24	1,672	1.93	1,772	1.44	1,772
4.48	2,729	KE302WB0175	MR160/050F	56C	17.29	676	3.91	2,919	3.37	3,100	2.53	3,100
4.48	2,729	KE302WB0175	MR160/140F	143/145TC	17.29	676	3.91	2,919	3.37	3,100	2.53	3,100
6.73	4,104	KE402WB0175	MR160/050F	56C	17.41	841	5.88	4,390	5.12	4,707	3.97	4,872
6.73	4,104	KE402WB0175	MR160/140F	143/145TC	17.41	841	5.88	4,390	5.12	4,707	3.97	4,872
6.73	4,104	KE402WB0175	MR200/180F	182/184TC	17.41	841	5.88	4,390	5.12	4,707	3.97	4,872
<b>90 RPM Output (Approximate)</b>							<b>70 RPM</b>	<b>55 RPM</b>	<b>43 RPM</b>			
2.32	1,644	KE202WB0200	MR160/050F	56C	20.33	468	2.03	1,759	1.66	1,772	1.24	1,772
2.32	1,644	KE202WB0200	MR160/140F	143/145TC	20.33	468	2.03	1,759	1.66	1,772	1.24	1,772
4.07	2,878	KE302WB0200	MR160/050F	56C	20.28	702	3.55	3,078	2.90	3,100	2.18	3,100
4.07	2,878	KE302WB0200	MR160/140F	143/145TC	20.28	702	3.55	3,078	2.90	3,100	2.18	3,100
6.09	4,312	KE402WB0200	MR160/050F	56C	20.20	873	5.33	4,613	4.56	4,872	3.42	4,872
6.09	4,312	KE402WB0200	MR160/140F	143/145TC	20.20	873	5.33	4,613	4.56	4,872	3.42	4,872
6.09	4,312	KE402WB0200	MR200/180F	182/184TC	20.20	873	5.33	4,613	4.56	4,872	3.42	4,872
<b>75 RPM Output (Approximate)</b>							<b>60 RPM</b>	<b>50 RPM</b>	<b>38 RPM</b>			
2.12	1,717	KE202WB0230	MR160/050F	56C	23.18	484	1.79	1,772	1.45	1,772	1.09	1,772
2.12	1,717	KE202WB0230	MR160/140F	143/145TC	23.18	484	1.79	1,772	1.45	1,772	1.09	1,772
3.73	3,013	KE302WB0230	MR160/050F	56C	23.29	726	3.13	3,100	2.54	3,100	1.91	3,100
3.73	3,013	KE302WB0230	MR160/140F	143/145TC	23.29	726	3.13	3,100	2.54	3,100	1.91	3,100
5.59	4,522	KE402WB0230	MR160/050F	56C	23.29	903	4.58	4,536	3.72	4,536	2.79	4,536
5.59	4,522	KE402WB0230	MR160/140F	143/145TC	23.29	903	4.89	4,838	3.99	4,872	2.99	4,872
5.59	4,522	KE402WB0230	MR200/180F	182/184TC	23.29	903	4.89	4,838	3.99	4,872	2.99	4,872

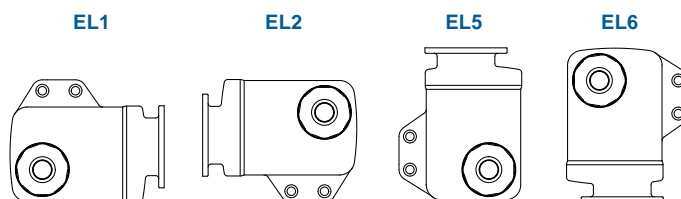

**Mounts in ANY Horizontal Output**







# Supreme Food Duty – "KE" Series MGS Reducer – Selection Data



### Selection Procedure:

- Under the Input RPM heading, find **Approximate Output RPM** nearest the requirement.
- In the **Input HP** column locate the rating that is greater than or equal to the required HP.  
(If selection is based on Torque instead of HP, find an **Output Torque** that is equal to or greater than required.)
- When HP or Torque rating is located, read across that row to select the **Part Number, Input Option and Overhung Loads**.
- If exact **Output RPM** is required, divide the **Input RPM** by the **Exact Ratio**.

1750 RPM Input		Part Number <sup>1)</sup>		NEMA C-Frame	Exact Ratio	Approximate Overhung Load <sup>2)</sup> lbs.	1450 RPM Input		1160 RPM Input		870 RPM Input	
Input HP	Output Torque in. lbs.	Base Module	Motor Adapter				Input HP	Output Torque in. lbs.	Input HP	Output Torque in. lbs.	Input HP	Output Torque in. lbs.
<b>70 RPM Output (Approximate)</b>												
2.00	1,764	KE202WB0250	MR160/050F	56C	25.13	494	1.64	1,772	1.33	1,772	1.00	1,772
2.00	1,764	KE202WB0250	MR160/140F	143/145TC	25.13	494	1.64	1,772	1.33	1,772	1.00	1,772
3.48	3,069	KE302WB0250	MR160/050F	56C	25.26	741	2.84	3,069	2.31	3,069	1.73	3,069
3.48	3,069	KE302WB0250	MR160/140F	143/145TC	25.26	741	2.84	3,069	2.31	3,069	1.73	3,069
5.03	4,434	KE402WB0250	MR160/050F	56C	25.28	923	4.11	4,434	3.33	4,434	2.50	4,434
5.03	4,434	KE402WB0250	MR160/140F	143/145TC	25.28	923	4.11	4,434	3.33	4,434	2.50	4,434
5.03	4,434	KE402WB0250	MR200/180F	182/184TC	25.28	923	4.11	4,434	3.33	4,434	2.50	4,434
<b>60 RPM Output (Approximate)</b>												
1.81	1,771	KE202WB0280	MR160/050F	56C	27.95	507	1.48	1,772	1.20	1,772	0.90	1,772
1.81	1,771	KE202WB0280	MR160/140F	143/145TC	27.95	507	1.48	1,772	1.20	1,772	0.90	1,772
3.18	3,100	KE302WB0280	MR160/050F	56C	27.88	760	2.60	3,100	2.11	3,100	1.58	3,100
3.18	3,100	KE302WB0280	MR160/140F	143/145TC	27.88	760	2.60	3,100	2.11	3,100	1.58	3,100
4.91	4,795	KE402WB0280	MR160/050F	56C	27.77	946	4.08	4,872	3.31	4,872	2.48	4,872
4.91	4,795	KE402WB0280	MR160/140F	143/145TC	27.77	946	4.08	4,872	3.31	4,872	2.48	4,872
4.91	4,795	KE402WB0280	MR200/180F	182/184TC	27.77	946	4.08	4,872	3.31	4,872	2.48	4,872
<b>55 RPM Output (Approximate)</b>												
1.16	1,364	KE202WB0340	MR160/050F	56C	33.62	531	0.95	1,364	0.77	1,364	0.58	1,364
1.16	1,364	KE202WB0340	MR160/140F	143/145TC	33.62	531	0.95	1,364	0.77	1,364	0.58	1,364
1.88	2,217	KE302WB0340	MR160/050F	56C	33.62	797	1.54	2,217	1.25	2,217	0.94	2,217
1.88	2,217	KE302WB0340	MR160/140F	143/145TC	33.62	797	1.54	2,217	1.25	2,217	0.94	2,217
2.93	3,444	KE402WB0340	MR160/050F	56C	33.68	992	2.39	3,445	1.94	3,445	1.46	3,445
2.93	3,444	KE402WB0340	MR160/140F	143/145TC	33.68	992	2.39	3,445	1.94	3,445	1.46	3,445
<b>50 RPM Output (Approximate)</b>												
1.45	1,771	KE202WB0350	MR160/050F	56C	34.55	536	1.19	1,772	0.96	1,772	0.72	1,772
1.45	1,771	KE202WB0350	MR160/140F	143/145TC	34.55	536	1.19	1,772	0.96	1,772	0.72	1,772
2.54	3,100	KE302WB0350	MR160/050F	56C	34.73	804	2.08	3,100	1.68	3,100	1.26	3,100
2.54	3,100	KE302WB0350	MR160/140F	143/145TC	34.73	804	2.08	3,100	1.68	3,100	1.26	3,100
3.99	4,871	KE402WB0350	MR160/050F	56C	34.76	1,001	2.23	3,325	1.81	3,325	1.35	3,325
3.99	4,871	KE402WB0350	MR160/140F	143/145TC	34.76	1,001	3.26	4,872	2.65	4,872	1.98	4,872
3.99	4,871	KE402WB0350	MR200/180F	182/184TC	34.76	1,001	3.26	4,872	2.65	4,872	1.98	4,872

\* For thermal HP capacity, see rating below.

Base Module	KE2	KE3	KE4
Thermal Capacity	5.36	7.38	12.34

NEMA Frame Size TEFC 1750 RPM	
C-Frame	Motor HP
56C	1/3 - 1 1/2
143/145TC	1, 1 1/2, 2
182/184TC	3, 5

### Part No. Explanation

KE 4 0 2 W B 0100 MR160 / 140 F - 108

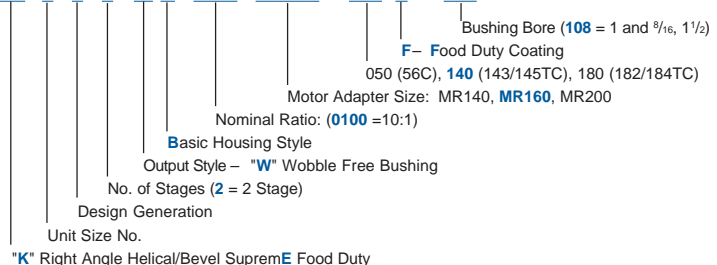



# Supreme Food Duty – "KE" Series MGS Reducer – Selection Data



- NOTE:** <sup>1)</sup> All KE units include the bushing. Complete the Part Number by adding the Bushing Bore Size. KE units will NOT be shipped unless the Bushing Bore is specified. Bushing Kits may be ordered separately to change the bore size.
- <sup>2)</sup> Hollow output units are not intended to support overhung loads. Use the load shown only as a reference.

1750 RPM Input		Part Number <sup>1)</sup>		NEMA C-Frame	Exact Ratio	Approximate Overhung Load <sup>2)</sup> lbs.	1450 RPM Input		1160 RPM Input		870 RPM Input	
Input HP	Output Torque in. lbs.	Base Module	Motor Adapter				Input HP	Output Torque in. lbs.	Input HP	Output Torque in. lbs.	Input HP	Output Torque in. lbs.
<b>45 RPM Output (Approximate)</b>							<b>35 RPM</b>	<b>30 RPM</b>	<b>20 RPM</b>			
1.20	1,705	KE302WB0410	MR160/050F	56C	40.51	835	0.98	1,705	0.80	1,705	0.60	1,705
1.20	1,705	KE302WB0410	MR160/140F	143/145TC	40.51	835	0.98	1,705	0.80	1,705	0.60	1,705
1.93	2,728	KE402WB0410	MR160/050F	56C	40.51	1,039	1.57	2,728	1.28	2,728	0.96	2,728
1.93	2,728	KE402WB0410	MR160/140F	143/145TC	40.51	1,039	1.57	2,728	1.28	2,728	0.96	2,728
<b>40 RPM Output (Approximate)</b>							<b>30 RPM</b>	<b>25 RPM</b>	<b>19 RPM</b>			
1.10	1,771	KE202WB0460	MR160/050F	56C	46.22	575	0.90	1,772	0.73	1,772	0.54	1,772
1.10	1,771	KE202WB0460	MR160/140F	143/145TC	46.22	575	0.90	1,772	0.73	1,772	0.54	1,772
1.88	3,048	KE302WB0460	MR160/050F	56C	46.22	863	1.54	3,048	1.25	3,048	0.94	3,048
1.88	3,048	KE302WB0460	MR160/140F	143/145TC	46.22	863	1.54	3,048	1.25	3,048	0.94	3,048
2.93	4,736	KE402WB0460	MR160/050F	56C	46.31	1,074	2.39	4,736	1.94	4,736	1.46	4,736
2.93	4,736	KE402WB0460	MR160/140F	143/145TC	46.31	1,074	2.39	4,736	1.94	4,736	1.46	4,736
<b>35 RPM Output (Approximate)</b>							<b>30 RPM</b>	<b>23 RPM</b>	<b>18 RPM</b>			
1.36	2,387	KE402WB0500	MR160/050F	56C	50.43	1,095	1.12	2,387	0.90	2,387	0.68	2,387
1.36	2,387	KE402WB0500	MR160/140F	143/145TC	50.43	1,095	1.12	2,387	0.90	2,387	0.68	2,387
<b>30 RPM Output (Approximate)</b>							<b>25 RPM</b>	<b>20 RPM</b>	<b>15 RPM</b>			
1.20	2,344	KE302WB0560	MR160/050F	56C	55.71	904	0.98	2,345	0.80	2,345	0.60	2,345
1.20	2,344	KE302WB0560	MR160/140F	143/145TC	55.71	904	0.98	2,345	0.80	2,345	0.60	2,345
1.93	3,752	KE402WB0560	MR160/050F	56C	55.71	1,125	1.57	3,752	1.28	3,752	0.96	3,752
1.93	3,752	KE402WB0560	MR160/140F	143/145TC	55.71	1,125	1.57	3,752	1.28	3,752	0.96	3,752
<b>25 RPM Output (Approximate)</b>							<b>20 RPM</b>	<b>18 RPM</b>	<b>13 RPM</b>			
1.36	3,282	KE402WB0690	MR160/050F	56C	69.34	1,188	1.11	3,283	0.90	3,283	0.67	3,283
1.36	3,282	KE402WB0690	MR160/140F	143/145TC	69.34	1,188	1.11	3,283	0.90	3,283	0.67	3,283

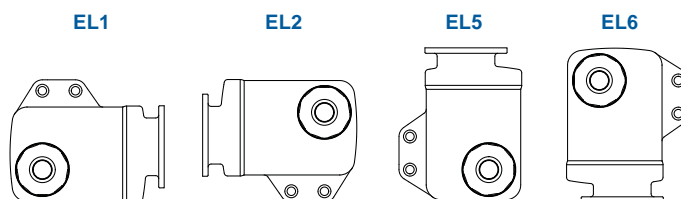

**Mounts in ANY Horizontal Output**

# Food Duty – "K" Series – MGS Reducers Right Angle Helical/Bevel



## Reducer Configurations

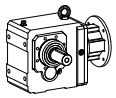

Style VG  
Output Shaft



Style VF  
Output Shaft  
Output Flange

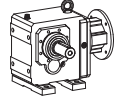

Style VN  
Output Shaft  
Mounting Feet



Style AG  
Hollow Output



Style AF  
Hollow Output  
Output Flange



Style AN  
Hollow Output  
Mounting Feet

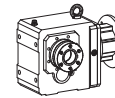

Style WG  
Double Bushing

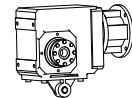

Style WGD  
Torque Arm  
Bracket

## Mounting Positions – Standard 3 Year Warranty

One Standard Unit for ALL Horizontal Mounting Positions Without Changing the Oil Level

Standard Oil: Mobile XP600

Optional Oil: Food Grade Oil (Exxon Univas Special Mist 220)

Synthetic Oil (Mobil SHC630)

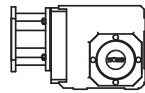

EL1

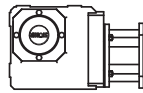

EL2

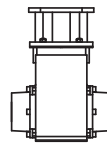

EL5

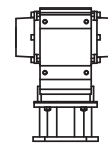

EL6

Possible – but not recommended

## Mounting Positions – Long Life 5 Year Warranty

Mounting Position **MUST BE SPECIFIED.**

Standard Oil: Synthetic Oil (Mobil SHC630)

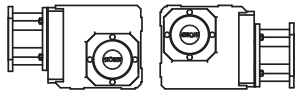

E12

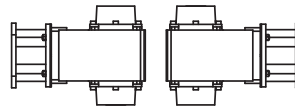

E34

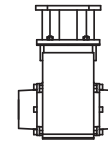

EL5

## Part No. Explanation with OPTIONS and REQUIREMENTS

**K 4 0 2 V N 0350 MR200 / 180 F LL E34**

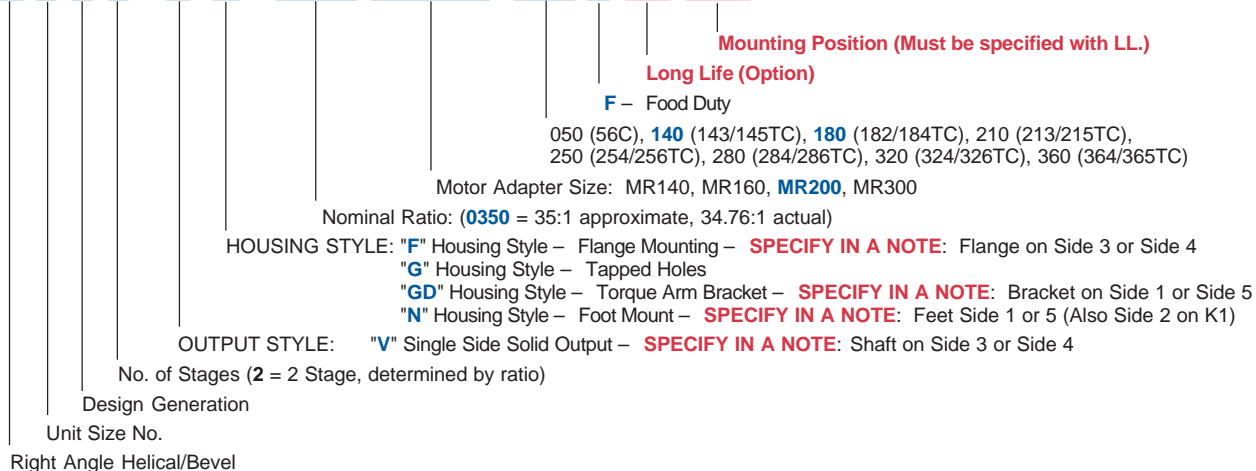

### THE FOLLOWING INFORMATION IS REQUIRED WHEN ORDERING:

- LL Mounting Position – E12, E34, EL5
- Feet Side – Side 1 or Side 5
- Flange Side – Side 3 or Side 4
- Shaft Side – Side 3 or Side 4

### THE FOLLOWING OPTIONS ARE AVAILABLE:

- Paint – White
- Oil – Food Grade, Synthetic





# Food Duty – "K" Series – MGS Reducers Right Angle Helical/Bevel

The standard "K" Series Helical/Bevel MGS Food Duty unit is supplied with a stainless steel output shaft. This unit has several features that make it virtually maintenance free in a **wet** or **dry** environment.

- Lubricated for Life
- Maintenance Free
- Totally Enclosed – no breather to allow contaminants in
- 3 Year Warranty – your guarantee of our confidence in the MGS (Modular Gear System) line of reducers
- 97% Efficiency – for high quality and reliability plus cost savings in energy and maintenance



- Standard Coating –
- 1, Primer
  - 2, Industrial 316 Stainless Steel Epoxy
  - 1, Silver Bullet Anti-Microbial™ Epoxy

Stainless Steel Nameplate



NEMA C-face Input

- O-ring between the motor and reducer
- Easy mount maintenance free coupling

Output Double Sealed – with a dual lip outer seal and a single lip inner seal

ALL Stainless Steel Hardware

High efficiency spiral bevel gearing provides quiet operation and excellent torque carrying capacity



High quality helical gearing is case hardened to 58-62 Rockwell C. Precision finished for low noise and long service life. Standard backlash is  $\leq 12$  arc minutes



K Series Food Duty hollow output units have bore sizes designed specifically for the poultry industry.

**See Pages 116-139 for Selection Data.**

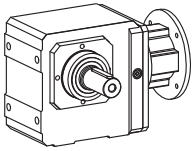

# Food Duty – "K" Series – MGS Reducer Tapped Holes – "G" Housing Shaft Output – Dimensional Data

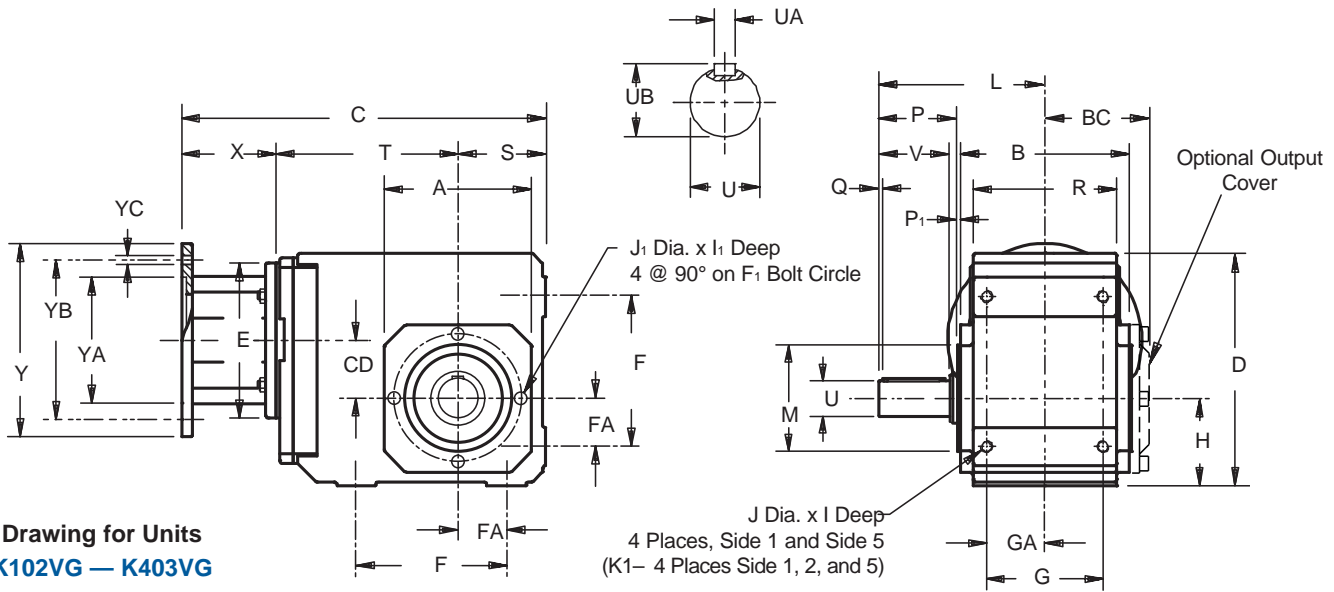

Drawing for Units  
K102VG – K403VG

Table No. 1 "K" Series – Unit Dimensions (Inches) – "G" Housing Style

Base Module	A	B	BC	D	F	F <sub>1</sub>	FA	G	GA	H	I	I <sub>1</sub>	J	J <sub>1</sub>	L
K102	4.13	4.17	2.64	6.30	3.54	3.54	1.18	2.76	1.38	2.36	.51	.51	M8	M8	4.53
K202/203	4.57	5.28	3.23	7.48	4.53	3.94	1.38	3.54	1.77	2.56	.63	.51	M10	M8	5.31
K302/303	5.20	5.75	3.46	8.39	5.12	4.53	1.57	4.13	2.07	2.95	.63	.51	M10	M8	5.59
K402/403	5.98	6.81	4.08	9.45	6.10	5.12	1.97	4.72	2.36	3.54	.75	.63	M12	M10	6.54
K513/514	5.71	7.28	4.31	10.24	5.51	5.12	1.57	4.92	2.46	6.30	1.02	.63	M16	M10	8.74
K613/614	7.09	7.87	4.61	12.20	6.30	6.50	1.97	5.12	2.56	7.48	1.02	.63	M16	M10	9.29
K713/714	7.68	8.90	5.08	13.46	7.09	7.28	2.17	5.71	2.85	8.35	1.22	.75	M20	M12	10.91
K813/814	8.90	11.10	6.26	16.14	9.45	8.46	2.95	7.28	3.64	10.43	1.50	.75	M24	M12	12.83

Table No. 2

Base Module	M	O	P	P <sub>1</sub>	R	Q	S	U	UA – Key	UB	V	Z <sub>1</sub>
K102	2.953	—	2.32	.12	3.54	.16	2.36	1.000	1/4 x 1/4 x 19/16	1.11	1.97	—
K202/203	3.228	—	2.56	.12	4.53	.16	2.56	1.250	1/4 x 1/4 x 115/16	1.36	2.36	—
K302/303	3.740	—	2.60	.12	5.12	.16	2.95	1.250	1/4 x 1/4 x 115/16	1.36	2.36	—
K402/403	4.331	—	3.39	.14	5.83	.16	3.54	1.375	5/16 x 5/16 x 25/16	1.51	2.76	—
K513/514	4.331	5.10	3.90	.14	6.30	.16	3.94	1.750	3/8 x 3/8 x 35/32	1.92	3.54	5.98
K613/614	5.512	5.35	4.31	.14	6.61	.16	4.72	1.750	3/8 x 3/8 x 35/32	1.92	3.94	6.77
K713/714	6.102	6.46	5.14	.14	7.48	.16	4.92	2.375	5/8 x 5/8 x 315/16	2.65	4.72	7.52
K813/814	7.283	7.28	5.94	.16	9.25	.20	5.71	2.875	3/4 x 3/4 x 45/16	3.21	5.51	8.11

Table No. 3 Motor Adapter Dimensions (Inches)

Motor Adapter	NEMA C-Flange	E	X	Y	YA	YB	YC	Wt. lbs.
MR140/050F	56C	5.51	3.31	6.50	4.500	5.87	.41	9
MR160/050F	56C	6.30	3.86	6.50	4.500	5.87	.41	16
MR160/140F	143/145TC	6.30	3.86	6.50	4.500	5.87	.41	16
MR200/180F	182/184TC	7.87	4.80	9.00	8.500	7.25	.55	23
MR250/180F	182/184TC	9.84	5.31	9.00	8.500	7.25	.55	36
MR250/210F	213/215TC	9.84	5.31	9.00	8.500	7.25	.55	36
MR300/180F	182/184TC	11.81	6.50	9.00	8.500	7.25	.57	75
MR300/210F	213/215TC	11.81	6.50	9.00	8.500	7.25	.57	75
MR300/250F	254/256TC	11.81	6.50	9.00	8.500	7.25	.57	75
MR300/280F	284/286TC	11.81	6.50	11.13	10.500	9.00	.57	75



# Food Duty – "K" Series – MGS Reducer Tapped Holes – "G" Housing Shaft Output – Dimensional Data

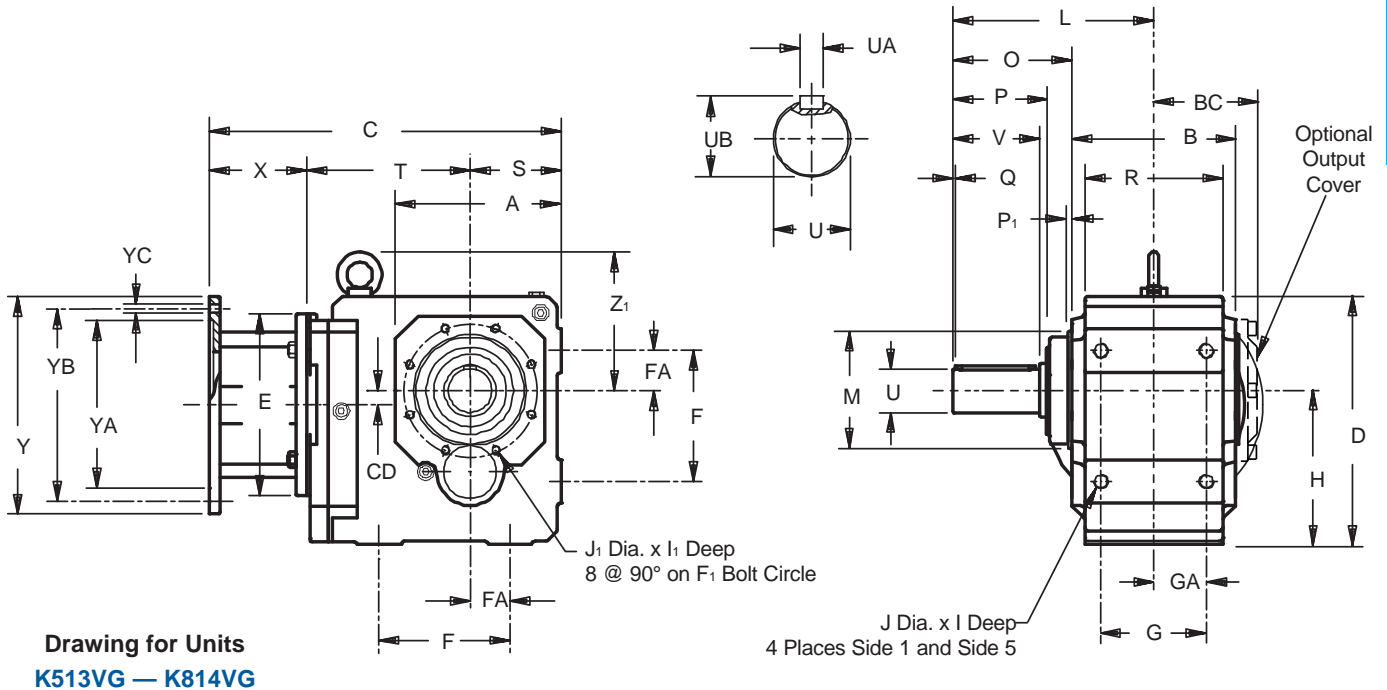
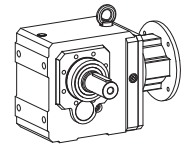

**Table No. 4 "K" Series – Unit Dimensions (Inches)**

Base Module	MR140/050F			MR160/140F <sup>1)</sup>			MR200/180F			MR250/210F <sup>2)</sup>			MR300/250F <sup>3)</sup>			Wt. lbs.
	CD	C	T	CD	C	T	CD	C	T	CD	C	T	CD	C	T	
K102	1.42	10.55	4.88	1.42	11.26	5.04	—	—	—	—	—	—	—	—	—	31
K202	1.81	11.50	5.63	1.81	12.21	5.79	1.81	13.23	5.87	—	—	—	—	—	—	40
K203	1.81	12.96	7.09	—	—	—	—	—	—	—	—	—	—	—	—	53
K302	2.07	12.68	6.42	2.07	13.38	6.57	2.07	14.40	6.65	—	—	—	—	—	—	67
K303	2.07	14.13	7.87	.63	15.08	8.27	—	—	—	—	—	—	—	—	—	73
K402	—	—	—	2.36	14.76	7.36	2.36	15.74	7.44	2.36	16.41	7.56	—	—	—	93
K403	2.36	15.51	8.66	.91	16.46	9.06	—	—	—	—	—	—	—	—	—	100
K513	—	—	—	.59	14.57	6.77	.59	15.59	6.85	.59	16.22	6.97	—	—	—	106
K514	—	—	—	.59	16.26	8.46	—	—	—	—	—	—	—	—	—	109
K613	—	—	—	.71	16.10	7.52	.71	17.12	7.60	.71	17.75	7.72	.71	19.49	8.27	170
K614	—	—	—	.71	17.79	9.21	—	—	—	—	—	—	—	—	—	177
K713	—	—	—	—	—	—	.79	18.42	8.70	.79	19.05	8.82	.79	20.75	9.33	221
K714	—	—	—	.79	19.13	10.35	.79	20.86	11.14	—	—	—	—	—	—	234
K813	—	—	—	—	—	—	.94	20.23	9.72	.94	20.82	9.80	.94	22.52	10.31	309
K814	—	—	—	—	—	—	.94	22.64	12.13	—	—	—	—	—	—	331

<sup>1)</sup> Also available as MR160/050F for a NEMA 56C frame motor.

<sup>2)</sup> Also available as MR250/180F for a NEMA 182/184TC frame motor.

<sup>3)</sup> Also available as MR300/180F for a NEMA 182/184TC, MR300/210F for a NEMA 213/215TC, and MR300/280F for a NEMA 284/286TC frame motor. All weights are approximate.

**Part No. Example**

Food Duty Unit  
with 143TC Frame Motor Adapter and Output Shaft  
**K303VG0650 MR160/140F**  
Specify: Shaft Side





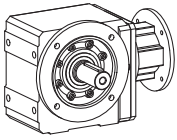

# Food Duty – "K" Series – MGS Reducer Round Flange – "F" Housing Shaft Output – Dimensional Data

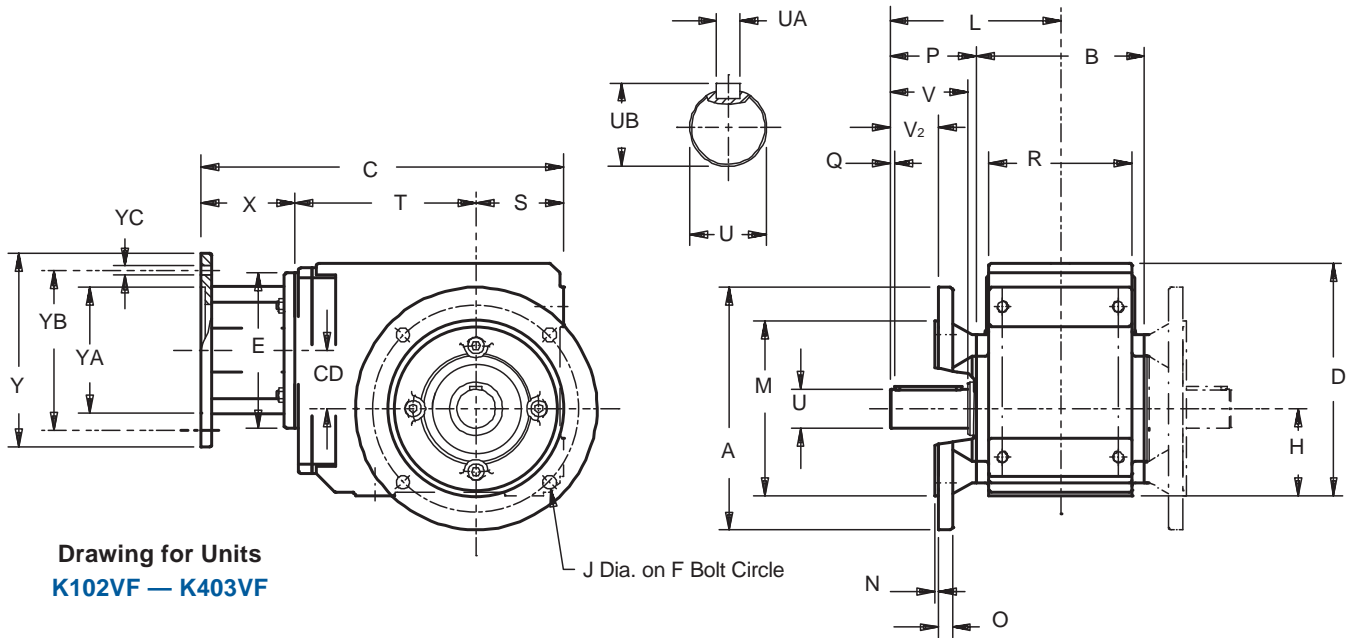

Drawing for Units  
K102VF – K403VF

Table No. 1 Food Duty – "K" Series – Round Flange Unit Dimensions (Inches) – "F" Housing Style

Base Module	A	B	D	F	H	J	L	M	N	O	P	Q	R	S	V	V <sub>2</sub>	Z <sub>1</sub>	
<b>K102</b>	6.30	4.17	6.30	5.12	2.36	.35	4.53	4.331	+0.001/-0.0004	.14	.39	2.44	.16	3.54	2.36	1.97	1.18	—
<b>K202/203</b>	7.87	5.28	7.48	6.50	2.56	.43	5.31	5.118	+0.001/-0.0004	.14	.47	2.68	.16	4.53	2.56	2.36	1.42	—
<b>K302/303</b>	7.87	5.75	8.39	6.50	2.95	.43	5.59	5.118	+0.001/-0.0004	.14	.55	2.72	.16	5.12	2.95	2.36	1.22	—
<b>K402/403</b>	9.84	6.81	9.45	8.46	3.54	.55	6.54	7.087	+0.001/-0.0004	.16	.59	3.52	.16	5.83	3.54	2.76	1.95	—
<b>K513/514</b>	9.84	7.28	10.24	8.46	6.30	.55	8.74	7.087	+0.001/-0.0004	.16	.59	5.10	.16	6.30	3.94	3.54	—	5.98
<b>K613/614</b>	11.81	7.87	12.20	10.43	7.48	.55	9.29	9.055	+0.001/-0.001	.16	.67	5.35	.16	6.61	4.72	3.94	—	6.77
<b>K713/714</b>	13.78	8.90	13.46	11.81	8.35	.71	10.91	9.842	+0.000/-0.001	.20	.71	6.46	.16	7.48	4.92	4.72	—	7.52
<b>K813/814</b>	15.75	11.10	16.14	13.78	10.43	.71	12.83	11.811	+0.000/-0.001	.20	.79	7.28	.20	9.25	5.71	5.51	—	8.11

Table No. 2 Motor Adapter Dimensions (Inches)

Motor Adapter	NEMA C-Flange	E	X	Y	YA	YB	YC	Wt. lbs.
<b>MR140/050F</b>	56C	5.51	3.31	6.50	4.500	5.87	.41	9
<b>MR160/050F</b>	56C	6.30	3.86	6.50	4.500	5.87	.41	16
<b>MR160/140F</b>	143/145TC	6.30	3.86	6.50	4.500	5.87	.41	16
<b>MR200/180F</b>	182/184TC	7.87	4.80	9.00	8.500	7.25	.55	23
<b>MR250/180F</b>	182/184TC	9.84	5.31	9.00	8.500	7.25	.55	36
<b>MR250/210F</b>	213/215TC	9.84	5.31	9.00	8.500	7.25	.55	36
<b>MR300/180F</b>	182/184TC	11.81	6.50	9.00	8.500	7.25	.57	75
<b>MR300/210F</b>	213/215TC	11.81	6.50	9.00	8.500	7.25	.57	75
<b>MR300/250F</b>	254/256TC	11.81	6.50	9.00	8.500	7.25	.57	75
<b>MR300/280F</b>	284/286TC	11.81	6.50	11.13	10.500	9.00	.57	75

Table No. 3

Base Module	Standard Shaft – inches		
	U	UA – Key	UB
<b>K102</b>	1.000	1/4 x 1/4 x 1 <sup>9</sup> / <sub>16</sub>	1.11
<b>K202/203</b>	1.250	1/4 x 1/4 x 1 <sup>15</sup> / <sub>16</sub>	1.36
<b>K302/303</b>	1.250	1/4 x 1/4 x 1 <sup>15</sup> / <sub>16</sub>	1.36
<b>K402/403</b>	1.375	5/16 x 5/16 x 2 <sup>5</sup> / <sub>16</sub>	1.51
<b>K513/514</b>	1.750	3/8 x 3/8 x 3 <sup>5</sup> / <sub>32</sub>	1.92
<b>K613/614</b>	1.750	3/8 x 3/8 x 3 <sup>5</sup> / <sub>32</sub>	1.92
<b>K713/714</b>	2.375	5/8 x 5/8 x 3 <sup>15</sup> / <sub>16</sub>	2.65
<b>K813/814</b>	2.875	3/4 x 3/4 x 4 <sup>5</sup> / <sub>16</sub>	3.21

Table No. 4 "K" Series – Optional Flanges (Inches)

Base Module	Flange Size	A	F	J	L	M	N	O
<b>K1</b>	140	5.512	4.53	.35	3.35	3.740	.12	.39
<b>K2</b>	160	6.300	5.12	.35	3.90	4.331	.14	.47
<b>K3</b>	160	6.300	5.12	.35	4.37	4.331	.14	.55
<b>K7</b>	300	11.811	10.43	.55	6.18	9.055	.20	.71
<b>K8</b>	350	13.780	11.81	.71	7.32	9.843	.20	.79
	450	17.717	15.75	.71	7.32	13.781	.20	.79

\* Optional flanges are not available in all sizes.



# Food Duty – "K" Series – MGS Reducer Round Flange – "F" Housing Shaft Output – Dimensional Data

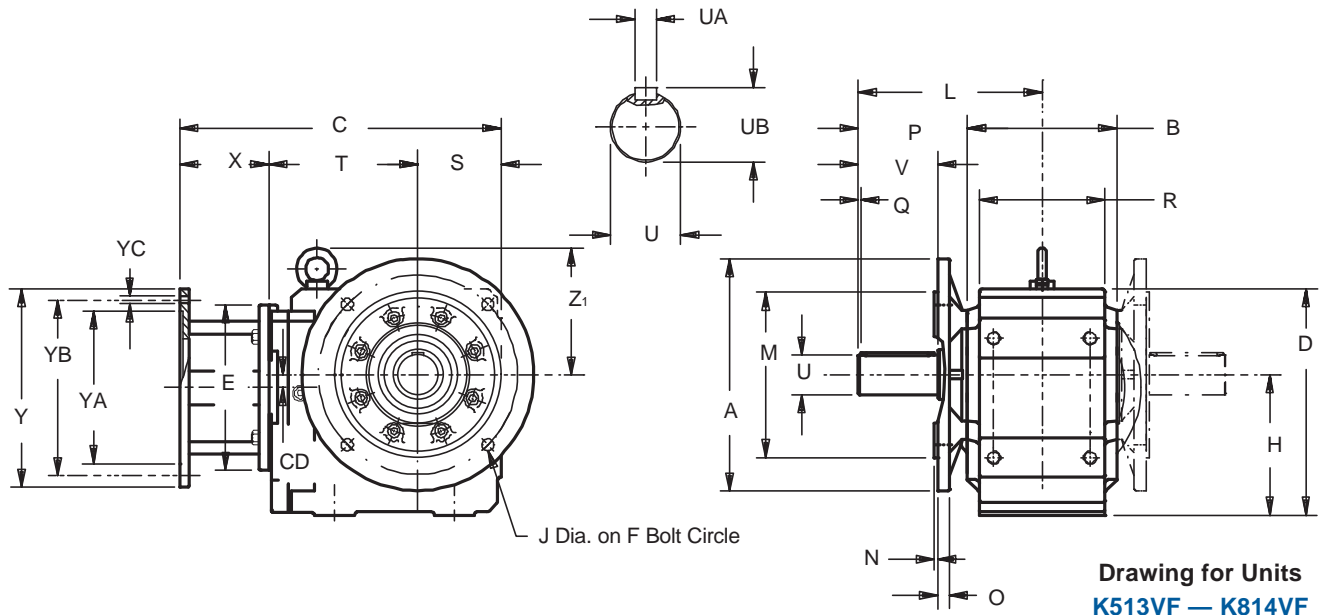
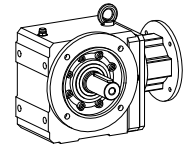

**Table No. 5 Food Duty – "K" Series – Flange Mounting Unit Dimensions (Inches) – "F" Housing Style**

Base	MR140/050F			MR160/140F <sup>1)</sup>			MR200/180F			MR250/210F <sup>2)</sup>			MR300/250F <sup>3)</sup>			Wt.
Module	CD	C	T	CD	C	T	CD	C	T	CD	C	T	CD	C	T	lbs.
K102	1.42	10.55	4.88	1.42	11.26	5.04	—	—	—	—	—	—	—	—	—	31
K202	1.81	11.50	5.63	1.81	12.21	5.79	1.81	13.23	5.87	—	—	—	—	—	—	40
K203	1.81	12.96	7.09	—	—	—	—	—	—	—	—	—	—	—	—	53
K302	2.07	12.68	6.42	2.07	13.38	6.57	2.07	14.40	6.65	—	—	—	—	—	—	67
K303	2.07	14.13	7.87	.63	15.08	8.27	—	—	—	—	—	—	—	—	—	73
K402	—	—	—	2.36	14.76	7.36	2.36	15.74	7.44	2.36	16.41	7.56	—	—	—	93
K403	2.36	15.51	8.66	.91	16.46	9.06	—	—	—	—	—	—	—	—	—	100
K513	—	—	—	.59	14.57	6.77	.59	15.59	6.85	.59	16.22	6.97	—	—	—	106
K514	—	—	—	.59	16.26	8.46	—	—	—	—	—	—	—	—	—	109
K613	—	—	—	.71	16.10	7.52	.71	17.12	7.60	.71	17.75	7.72	.71	19.49	8.27	170
K614	—	—	—	.71	17.79	9.21	—	—	—	—	—	—	—	—	—	177
K713	—	—	—	—	—	—	.79	18.42	8.70	.79	19.05	8.82	.79	20.75	9.33	221
K714	—	—	—	.79	19.13	10.35	.79	20.86	11.14	—	—	—	—	—	—	234
K813	—	—	—	—	—	—	.94	20.23	9.72	.94	20.82	9.80	.94	22.52	10.31	309
K814	—	—	—	—	—	—	.94	22.64	12.13	—	—	—	—	—	—	331

<sup>1)</sup> Also available as **MR160/050F** for a NEMA 56C frame motor.

<sup>2)</sup> Also available as **MR250/180F** for a NEMA 182/184TC frame motor.

<sup>3)</sup> Also available as **MR300/180F** for a NEMA 182/184TC, **MR300/210F** for a NEMA 213/215TC, and **MR300/280F** for a NEMA 284/286TC frame motor.

All weights are approximate.

### Part No. Example

Food Duty  
Round Flange with Motor Adapter

**K303VF0650 MR160/140F**

**Specify: Shaft and Flange Side**

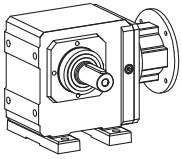

# Food Duty – "K" Series – MGS Reducer Foot Mount – "N" Housing Shaft Output – Dimensional Data

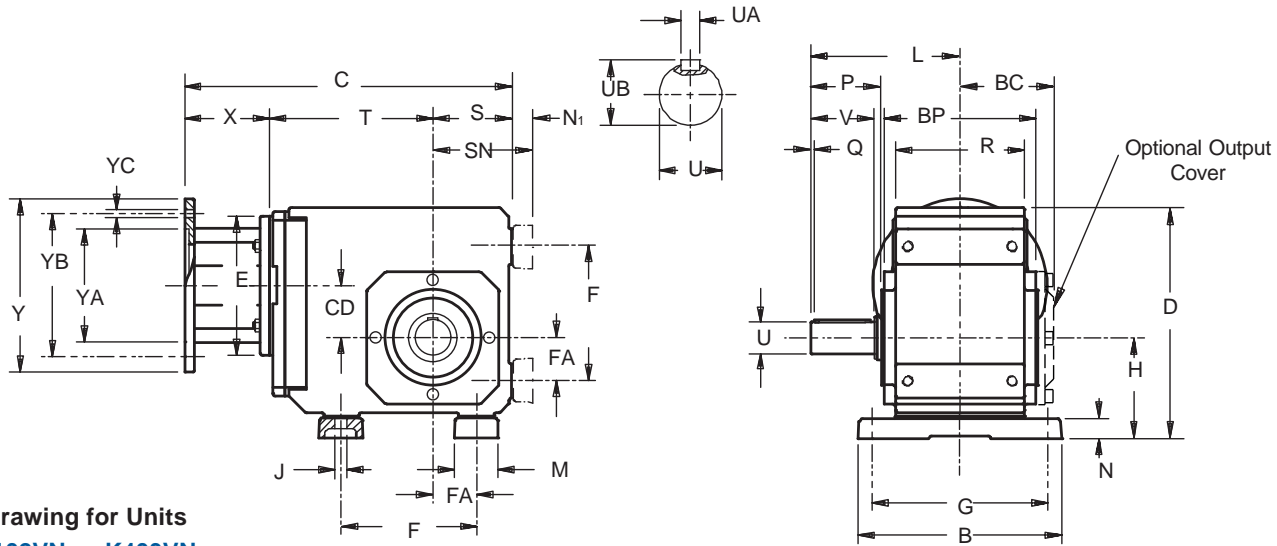

Drawing for Units  
K102VN – K403VN

Table No. 1 "K" Series – Foot Mounting Unit Dimensions (Inches) – "N" Housing Style

Base Module	B	D	F	G	H	J <sup>1)</sup>	L	M	N	O	P	Q	R	S	V	Z <sub>1</sub>	BC	BP	FA	N <sub>1</sub>	SN
<b>K102</b>	5.51	6.81	3.54 <sup>1)</sup>	4.53	2.95	.35	4.53	1.18	.51	—	2.32	.16	3.54	2.36	1.97	—	2.64	4.17	1.18	.59	2.95
<b>K202/203</b>	7.28	8.39	4.53	6.10	3.46	.43	5.31	1.57	.79	—	2.56	.16	4.53	2.56	2.36	—	3.23	5.28	1.38	.91	3.46
<b>K302/303</b>	7.87	9.29	5.12	6.69	3.86	.43	5.59	1.77	.79	—	2.60	.16	5.12	2.95	2.36	—	3.46	5.75	1.57	.91	3.86
<b>K402/403</b>	9.06	10.43	6.10	7.87	4.53	.55	6.54	1.97	.87	—	3.39	.16	5.83	3.54	2.76	—	4.08	6.81	1.97	.98	4.53
<b>K513/514</b>	9.45	11.42	5.51	7.87	7.48	.71	8.74	2.36	1.06	5.10	3.90	.16	6.30	3.94	3.54	5.98	4.31	7.28	1.57	1.18	5.12
<b>K613/614</b>	9.84	13.39	6.30	8.27	8.66	.71	9.29	2.56	1.06	5.35	4.31	.16	6.61	4.72	3.94	6.77	4.61	7.87	1.97	1.18	5.91
<b>K713/714</b>	11.42	14.96	7.09	9.45	9.84	.87	10.91	2.76	1.38	6.46	5.14	.16	7.48	4.92	4.72	7.52	5.08	8.90	2.17	1.50	6.42
<b>K813/814</b>	14.17	17.91	9.45	11.81	12.20	1.02	12.83	3.35	1.61	7.28	5.94	.20	9.25	5.71	5.51	8.11	6.26	11.10	2.95	1.77	7.48

<sup>1)</sup> Mounting holes are also located also on Side 1 of the K1 unit ONLY.

Table No. 2 Motor Adapter Dimensions (Inches)

Motor Adapter	NEMA C-Flange	E	X	Y	YA	YB	YC	Wt. lbs.
<b>MR140/050F</b>	56C	5.51	3.31	6.50	4.500	5.87	.41	9
<b>MR160/050F</b>	56C	6.30	3.86	6.50	4.500	5.87	.41	16
<b>MR160/140F</b>	143/145TC	6.30	3.86	6.50	4.500	5.87	.41	16
<b>MR200/180F</b>	182/184TC	7.87	4.80	9.00	8.500	7.25	.55	23
<b>MR250/180F</b>	182/184TC	9.84	5.31	9.00	8.500	7.25	.55	36
<b>MR250/210F</b>	213/215TC	9.84	5.31	9.00	8.500	7.25	.55	36
<b>MR300/180F</b>	182/184TC	11.81	6.50	9.00	8.500	7.25	.57	75
<b>MR300/210F</b>	213/215TC	11.81	6.50	9.00	8.500	7.25	.57	75
<b>MR300/250F</b>	254/256TC	11.81	6.50	9.00	8.500	7.25	.57	75
<b>MR300/280F</b>	284/286TC	11.81	6.50	11.13	10.500	9.00	.57	75

Table No. 3

Base Module	Standard Shaft – inches		
	U	UA – Key	UB
<b>K102</b>	1.000	1/4 x 1/4 x 1 <sup>9</sup> / <sub>16</sub>	1.11
<b>K202/203</b>	1.250	1/4 x 1/4 x 1 <sup>15</sup> / <sub>16</sub>	1.36
<b>K302/303</b>	1.250	1/4 x 1/4 x 1 <sup>15</sup> / <sub>16</sub>	1.36
<b>K402/403</b>	1.375	5/16 x 5/16 x 2 <sup>5</sup> / <sub>16</sub>	1.51
<b>K513/514</b>	1.750	3/8 x 3/8 x 3 <sup>5</sup> / <sub>32</sub>	1.92
<b>K613/614</b>	1.750	3/8 x 3/8 x 3 <sup>5</sup> / <sub>32</sub>	1.92
<b>K713/714</b>	2.375	5/8 x 5/8 x 3 <sup>15</sup> / <sub>16</sub>	2.65
<b>K813/814</b>	2.875	3/4 x 3/4 x 4 <sup>5</sup> / <sub>16</sub>	3.21

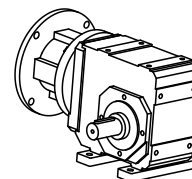

K1 Housing with tapped holes on Side 1, Side 2, and Side 5. Shown with mounting feet on Side 1.





# Food Duty – "K" Series – MGS Reducer Foot Mount – "N" Housing Shaft Output – Dimensional Data

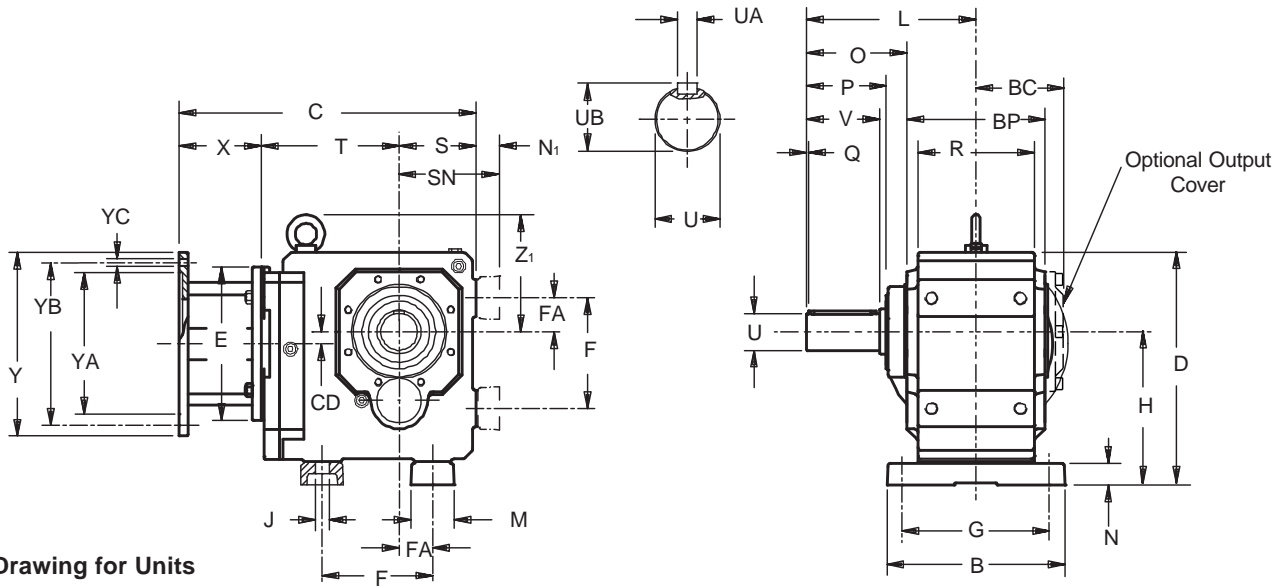
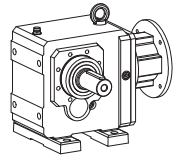

**Table No. 4 Food Duty – "K" Series – Foot Mounting Unit Dimensions (Inches) – "N" Housing Style**

Base	MR140/050F			MR160/140F <sup>2)</sup>			MR200/180F			MR250/210F <sup>3)</sup>			MR300/250F <sup>4)</sup>			Wt.
Module	CD	C	T	CD	C	T	CD	C	T	CD	C	T	CD	C	T	lbs.
K102	1.42	10.55	4.88	1.42	11.26	5.04	—	—	—	—	—	—	—	—	—	31
K202	1.81	11.50	5.63	1.81	12.21	5.79	1.81	13.23	5.87	—	—	—	—	—	—	40
K203	1.81	12.96	7.09	—	—	—	—	—	—	—	—	—	—	—	—	53
K302	2.07	12.68	6.42	2.07	13.38	6.57	2.07	14.40	6.65	—	—	—	—	—	—	67
K303	2.07	14.13	7.87	.63	15.08	8.27	—	—	—	—	—	—	—	—	—	73
K402	—	—	—	2.36	14.76	7.36	2.36	15.74	7.44	2.36	16.41	7.56	—	—	—	93
K403	2.36	15.51	8.66	.91	16.46	9.06	—	—	—	—	—	—	—	—	—	100
K513	—	—	—	.59	14.57	6.77	.59	15.59	6.85	.59	16.22	6.97	—	—	—	106
K514	—	—	—	.59	16.26	8.46	—	—	—	—	—	—	—	—	—	109
K613	—	—	—	.71	16.10	7.52	.71	17.12	7.60	.71	17.75	7.72	.71	19.49	8.27	170
K614	—	—	—	.71	17.79	9.21	—	—	—	—	—	—	—	—	—	177
K713	—	—	—	—	—	—	.79	18.42	8.70	.79	19.05	8.82	.79	20.75	9.33	221
K714	—	—	—	.79	19.13	10.35	.79	20.86	11.14	—	—	—	—	—	—	234
K813	—	—	—	—	—	—	.94	20.23	9.72	.94	20.82	9.80	.94	22.52	10.31	309
K814	—	—	—	—	—	—	.94	22.64	12.13	—	—	—	—	—	—	331

<sup>2)</sup> Also available as **MR160/050F** for a NEMA 56C frame motor.

<sup>3)</sup> Also available as **MR250/180F** for a NEMA 182/184TC frame motor.

<sup>4)</sup> Also available as **MR300/180F** for a NEMA 182/184TC, **MR300/210F** for a NEMA 213/215TC, and **MR300/280F** for a NEMA 284/286TC frame motor.

All weights are approximate.

### Part No. Example

Food Duty  
Foot Mounting with Motor Adapter

**K303VN0650 MR160/140F**

**Specify: Shaft and Feet Side**

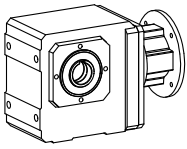

# Food Duty – "K" Series – MGS Reducers Tapped Hole – "G" Housing Hollow Output – Dimensional Data

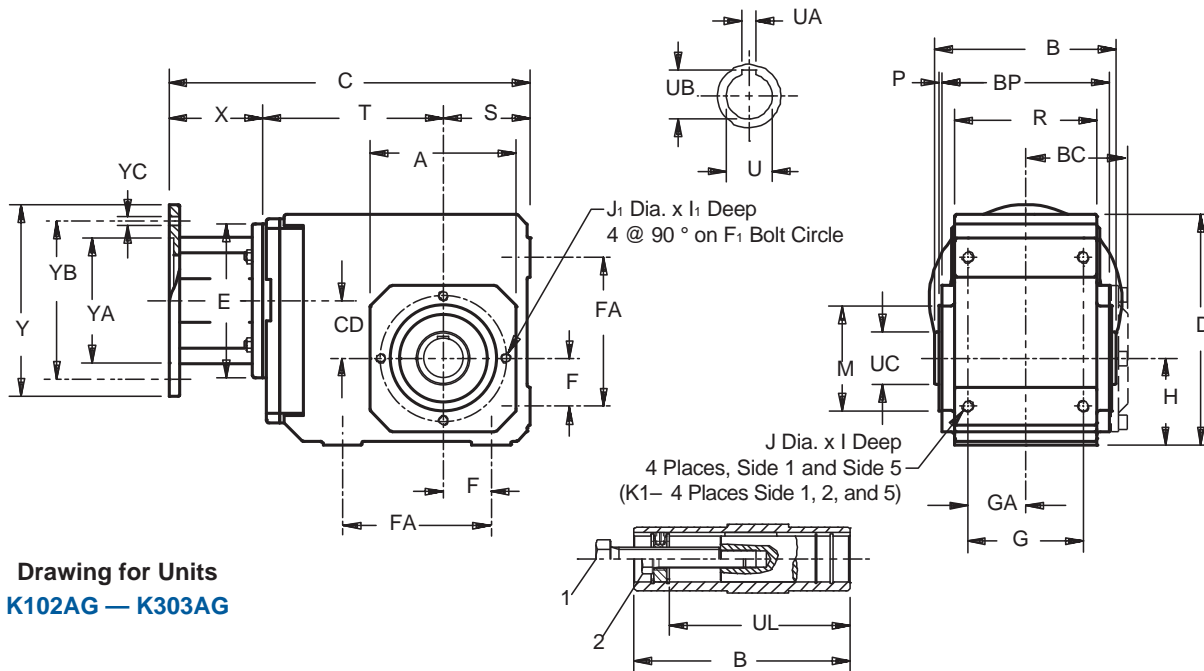

Drawing for Units  
K102AG — K303AG

Table No. 1 Food Duty "K" Series – Unit Dimensions (Inches) – "G" Housing Style

Base Module	A	B	D	F	F <sub>1</sub>	G	H	I	I <sub>1</sub>	J	J <sub>1</sub>	M	P	R	S	BC	BP	FA	GA
<b>K102</b>	4.13	4.72	6.30	3.54	3.54	2.76	2.36	.51	.51	M8	M8	2.953	.12	3.54	2.36	2.49	4.17	1.18	1.38
<b>K202/203</b>	4.57	5.83	7.48	4.53	3.94	3.54	2.56	.63	.51	M10	M8	3.228	.12	4.53	2.56	3.25	5.28	1.38	1.77
<b>K302/303</b>	5.20	6.30	8.39	5.12	4.53	4.13	2.95	.63	.51	M10	M8	3.740	.12	5.12	2.95	3.47	5.75	1.57	2.07

Table No. 2 Standard Bore (Inches)

Base Module	U	UA	UB	UC	UL	1
<b>K102</b>	1.000	.250	1.12	.157	3.86	1/2-13
<b>K202/203</b>	1.250	.250	1.37	.177	4.78	1/2-13
<b>K302/303</b>	1.250	.250	1.37	1.97	4.92	5/8-11
	1.375	.312	1.52	1.97	4.92	5/8-11

1. Removal Bolt —not supplied.
  2. Mounting Bolt —must be smaller than removal bolt.
- All weights are approximate.

Table No. 3 Motor Adapter Dimensions (Inches)

Motor Adapter	NEMA C-Flange	E	X	Y	YA	YB	YC	Wt. lbs.
<b>MR140/050F</b>	56C	5.51	3.31	6.50	4.500	5.87	.41	9
<b>MR160/050F</b>	56C	6.30	3.86	6.50	4.500	5.87	.41	16
<b>MR160/140F</b>	143/145TC	6.30	3.86	6.50	4.500	5.87	.41	16
<b>MR200/180F</b>	182/184TC	7.87	4.80	9.00	8.500	7.25	.55	23

Table No. 4 "K" Series – Unit Dimensions (Inches)

Base Module	MR140/050F			MR160/140F <sup>1)</sup>			MR200/180F			Wt. lbs.
	CD	C	T	CD	C	T	CD	C	T	
<b>K102</b>	1.42	10.55	4.88	1.42	11.26	5.04	—	—	—	31
<b>K202</b>	1.81	11.50	5.63	1.81	12.21	5.79	1.81	13.23	5.87	40
<b>K203</b>	1.81	12.96	7.09	—	—	—	—	—	—	53
<b>K302</b>	2.07	12.68	6.42	2.07	13.38	6.57	2.07	14.40	6.65	67
<b>K303</b>	2.07	14.13	7.87	.63	15.08	8.27	—	—	—	73

<sup>1)</sup> Also available as MR160/050F for a NEMA 56C frame motor.

**Part No. Example**  
Food Duty  
Tapped Holes Housing and Hollow Output  
**K303AG0650 MR160/140F**  
**Specify Bore Size (K3 ONLY)**



# Food Duty – "K" Series – MGS Reducers Round Flange – "F" Housing Hollow Output – Dimensional Data

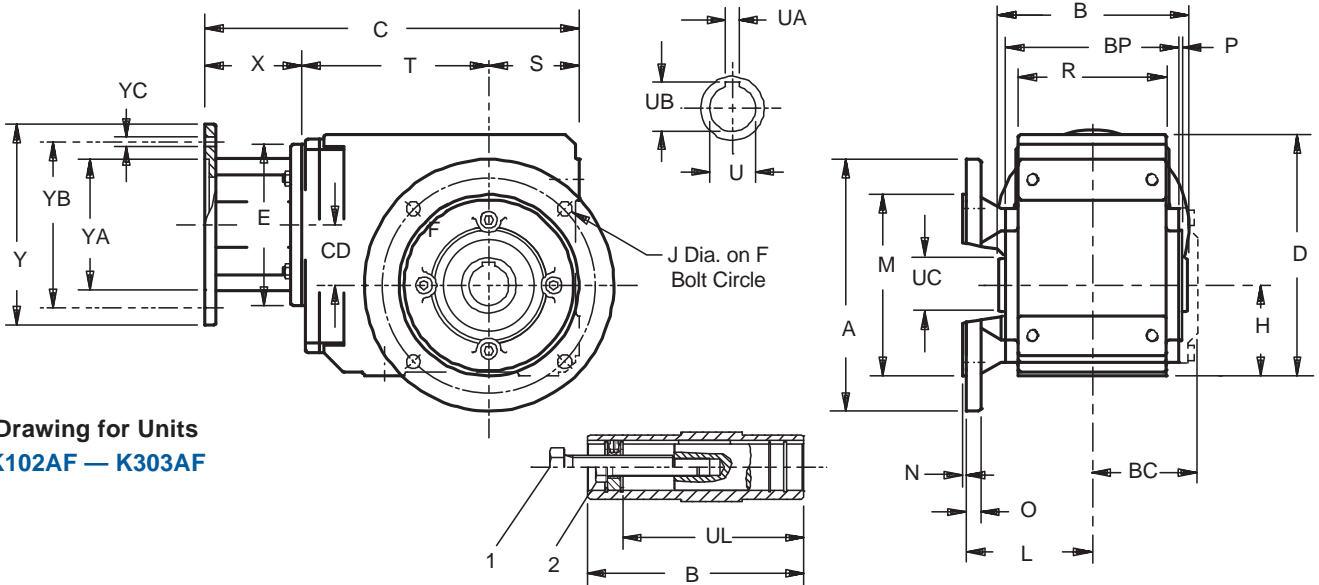
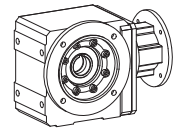

Drawing for Units  
K102AF – K303AF

Table No. 1 Food Duty "K" Series – Unit Dimensions (Inches) – "F" Housing Style

Base Module	A	B	D	F	H	J	L	M	N	O	P	R	S	BP	BC	UC	UL	1
<b>K102</b>	6.30	4.72	6.30	5.12	2.36	.35	4.53	4.331 +.001/-.0004	.14	.39	2.44	3.54	2.36	4.17	2.49	1.57	3.86	1/2-13
<b>K202/203</b>	7.87	5.83	7.48	6.50	2.56	.43	5.31	5.118 +.001/-.0004	.14	.47	2.68	4.53	2.56	5.28	3.25	1.77	4.78	1/2-13
<b>K302/303</b>	7.87	6.30	8.39	6.50	2.95	.43	5.59	5.118 +.001/-.0004	.14	.55	2.72	5.12	2.95	5.75	3.47	1.97	4.92	5/8-11

1. Removal Bolt —not supplied.
  2. Mounting Bolt —must be smaller than removal bolt.
- All weights are approximate.

Table No. 2 Motor Adapter Dimensions (Inches)

Motor Adapter	NEMA C-Flange	E	X	Y	YA	YB	YC	Wt. lbs.
<b>MR140/050F</b>	56C	5.51	3.31	6.50	4.500	5.87	.41	9
<b>MR160/050F</b>	56C	6.30	3.86	6.50	4.500	5.87	.41	16
<b>MR160/140F</b>	143/145TC	6.30	3.86	6.50	4.500	5.87	.41	16
<b>MR200/180F</b>	182/184TC	7.87	4.80	9.00	8.500	7.25	.55	23

Table No. 3 Standard Bore (ins.)

Base Module	U	UA	UB
<b>K102</b>	1.000	.250	1.12
<b>K202/203</b>	1.250	250	1.37
<b>K302/303</b>	1.250	250	1.37
	1.375	.312	1.52

Table No. 4 "K" Series – Unit Dimensions (Inches)

Base Module	MR140/050F			MR160/140F <sup>1)</sup>			MR200/180F			Wt. lbs.
	CD	C	T	CD	C	T	CD	C	T	
<b>K102</b>	1.42	10.55	4.88	1.42	11.26	5.04	—	—	—	31
<b>K202</b>	1.81	11.50	5.63	1.81	12.21	5.79	1.81	13.23	5.87	40
<b>K203</b>	1.81	12.96	7.09	—	—	—	—	—	—	53
<b>K302</b>	2.07	12.68	6.42	2.07	13.38	6.57	2.07	14.40	6.65	67
<b>K303</b>	2.07	14.13	7.87	.63	15.08	8.27	—	—	—	73

<sup>1)</sup> Also available as **MR160/050F** for a NEMA 56C frame motor.

Table No. 5 "K" Series – Optional Flanges (Inches)

Base Module	Flange Size	A	F	J	L	M	N	O
<b>K102</b>	140	5.512	4.53	.35	3.35	3.740	.12	.39
<b>K202/K203</b>	160	6.300	5.12	.35	3.90	4.331	.14	.47
<b>K302/K303</b>	160	6.300	5.12	.35	4.37	4.331	.14	.55

## Part No. Example

Food Duty  
Output Flange and Hollow Output  
**K303AF0650 MR160/140F**  
Specify Bore Size (K3 ONLY)

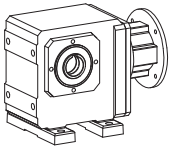

# Food Duty – "K" Series – MGS Reducers Foot Mount – "N" Housing Hollow Output – Dimensional Data

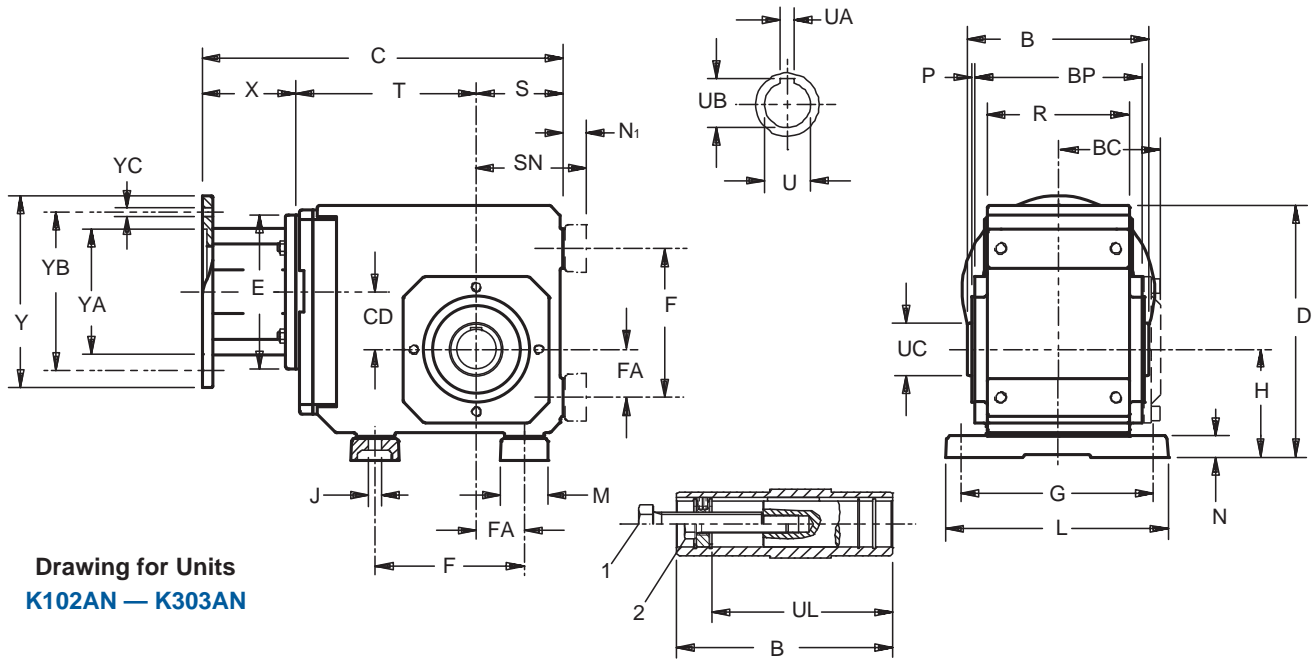

Drawing for Units  
K102AN – K303AN

Table No. 1 Food Duty "K" Series – Unit Dimensions (Inches) – "N" Housing Style

Base Module	B	D	F	G	H	J	L	M	N	N <sub>1</sub>	P	R	S	BC	BP	FA	GA	SN	UC	UL	1
<b>K102</b>	4.72	6.30	3.54	4.53 <sup>1)</sup>	2.36	.35 <sup>1)</sup>	5.51	1.18	.51	.59	.16	3.54	2.36	2.49	4.17	1.18	1.38 <sup>1)</sup>	2.95	1.57	3.86	1/2-13
<b>K202/203</b>	5.83	7.48	4.53	6.10	2.56	.43	7.28	1.57	.79	.91	.16	4.53	2.56	3.25	5.28	1.38	1.77	3.46	1.77	4.78	1/2-13
<b>K302/303</b>	6.30	8.39	5.12	6.69	2.95	.43	7.87	1.77	.79	.91	.16	5.12	2.95	3.47	5.75	1.57	2.07	3.86	1.97	4.92	5/8-11

<sup>1)</sup> K102 can bolt mounting feet on Side 1 (bottom), Side 2 (top), and Side 5.

Table No. 2 Standard Bore (ins.)

Base Module	U	UA	UB
<b>K102</b>	1.000	.250	1.12
<b>K202/203</b>	1.250	250	1.37
<b>K302/303</b>	1.250	250	1.37
	1.375	.312	1.52

Table No. 3 Motor Adapter Dimensions (Inches)

Motor Adapter	NEMA C-Flange	E	X	Y	YA	YB	YC	Wt. lbs.
<b>MR140/050F</b>	56C	5.51	3.31	6.50	4.500	5.87	.41	9
<b>MR160/050F</b>	56C	6.30	3.86	6.50	4.500	5.87	.41	16
<b>MR160/140F</b>	143/145TC	6.30	3.86	6.50	4.500	5.87	.41	16
<b>MR200/180F</b>	182/184TC	7.87	4.80	9.00	8.500	7.25	.55	23

Table No. 4 Food Duty – "K" Series – Dimensions (Inches)

Base Module	MR140/050F			MR160/140F <sup>2)</sup>			MR200/180F			Wt. lbs.
	CD	C	T	CD	C	T	CD	C	T	
<b>K102</b>	1.42	10.55	4.88	1.42	11.26	5.04	—	—	—	31
<b>K202</b>	1.81	11.50	5.63	1.81	12.21	5.79	1.81	13.23	5.87	40
<b>K203</b>	1.81	12.96	7.09	—	—	—	—	—	—	53
<b>K302</b>	2.07	12.68	6.42	2.07	13.38	6.57	2.07	14.40	6.65	67
<b>K303</b>	2.07	14.13	7.87	.63	15.08	8.27	—	—	—	73

<sup>2)</sup> Also available as **MR160/050F** for a NEMA 56C frame motor.

1. Removal Bolt —not supplied.
2. Mounting Bolt —must be smaller than removal bolt. All weights are approximate.

### Part No. Example

Food Duty  
Foot Mounting and Hollow Output

**K303AN0650 MR160/140F**

**Specify Bore Size (K3 ONLY)**





# Food Duty – "K" Series – MGS Reducers Torque Arm Bracket – "GD" Housing Hollow Output – Dimensional Data

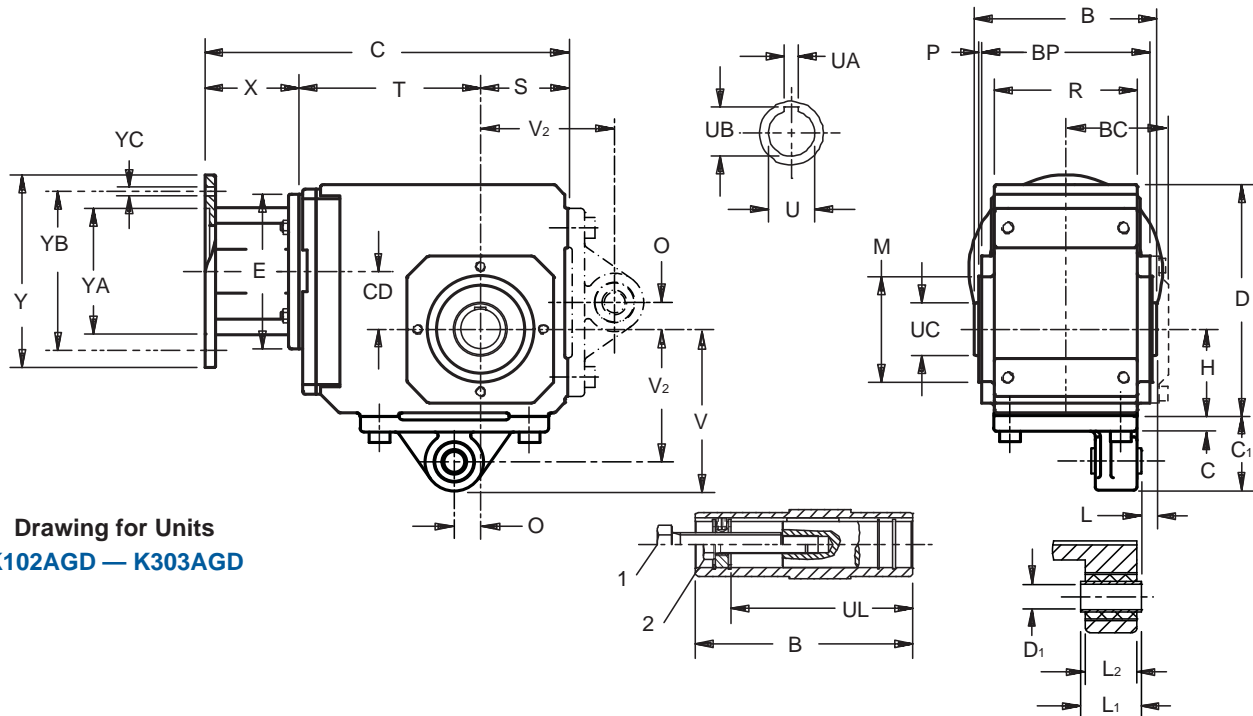
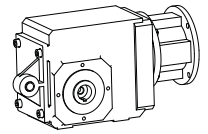

Drawing for Units  
K102AGD — K303AGD

Table No. 1 Food Duty "K" Series – Unit Dimensions (Inches) – "GD" Housing Style

Base Module	B	C	C <sub>1</sub>	D	D <sub>1</sub>	H <sub>9</sub>	H	L	L <sub>1</sub>	L <sub>2</sub>	M	O	P	R	S	V	V <sub>2</sub>	BC	BP
<b>K102</b> <sup>1)</sup>	4.72	.39	2.03	6.30	.47	$+0.017/-0.000$	2.36	5.51	1.10	.94	1.18	.59	.16	3.54	2.36	4.39	3.54	2.49	4.17
<b>K202/203</b>	5.83	.47	2.26	7.48	.63	$+0.017/-0.000$	2.56	7.28	1.50	1.26	1.57	.89	.16	4.53	2.56	4.82	3.93	3.25	5.28
<b>K302/303</b>	6.30	.47	2.66	8.39	.63	$+0.017/-0.000$	2.95	7.87	1.50	1.26	1.77	.98	.16	5.12	2.95	5.61	4.72	3.47	5.75

<sup>1)</sup> K102 can bolt torque arm bracket on Side 1 (bottom), Side 2 (top), and Side 5.

Table No. 2 Standard Bore (Inches)

Base Module	U	UA	UB	UC	UL	1
<b>K102</b>	1.000	.250	1.12	1.57	3.86	1/2-13
<b>K202/203</b>	1.250	.250	1.37	1.77	4.78	1/2-13
<b>K302/303</b>	1.250	.250	1.37	1.97	4.92	5/8-11
	1.375	.312	1.52	1.97	4.92	5/8-11

Table No. 3 Motor Adapter Dimensions (Inches)

Motor Adapter	NEMA C-Flange	E	X	Y	YA	YB	YC	Wt. lbs.
<b>MR140/050F</b>	56C	5.51	3.31	6.50	4.500	5.87	.41	9
<b>MR160/050F</b>	56C	6.30	3.86	6.50	4.500	5.87	.41	16
<b>MR160/140F</b>	143/145TC	6.30	3.86	6.50	4.500	5.87	.41	16
<b>MR200/180F</b>	182/184TC	7.87	4.80	9.00	8.500	7.25	.55	23

Table No. 4 Food Duty – "K" Series – Dimensions (Inches)

Base Module	MR140/050F			MR160/140F <sup>2)</sup>			MR200/180F			Wt. lbs.
	CD	C	T	CD	C	T	CD	C	T	
<b>K102</b>	1.42	10.55	4.88	1.42	11.26	5.04	—	—	—	31
<b>K202</b>	1.81	11.50	5.63	1.81	12.21	5.79	1.81	13.23	5.87	40
<b>K203</b>	1.81	12.96	7.09	—	—	—	—	—	—	53
<b>K302</b>	2.07	12.68	6.42	2.07	13.38	6.57	2.07	14.40	6.65	67
<b>K303</b>	2.07	14.13	7.87	.63	15.08	8.27	—	—	—	73

<sup>2)</sup> Also available as **MR160/050F** for a NEMA 56C frame motor.

- 1. Removal Bolt —not supplied.
  - 2. Mounting Bolt —must be smaller than removal bolt.
- All weights are approximate.

### Part No. Example

Food Duty with Torque Arm Bracket  
Tapped Holes Housing and Hollow Output  
**K303AGD0650 MR160/140F**  
**Specify Bore Size (K3 ONLY)**



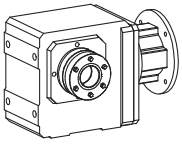

# Food Duty – "K" Series – MGS Reducer Tapped Hole – "G" Housing Double Bushing – Dimensional Data

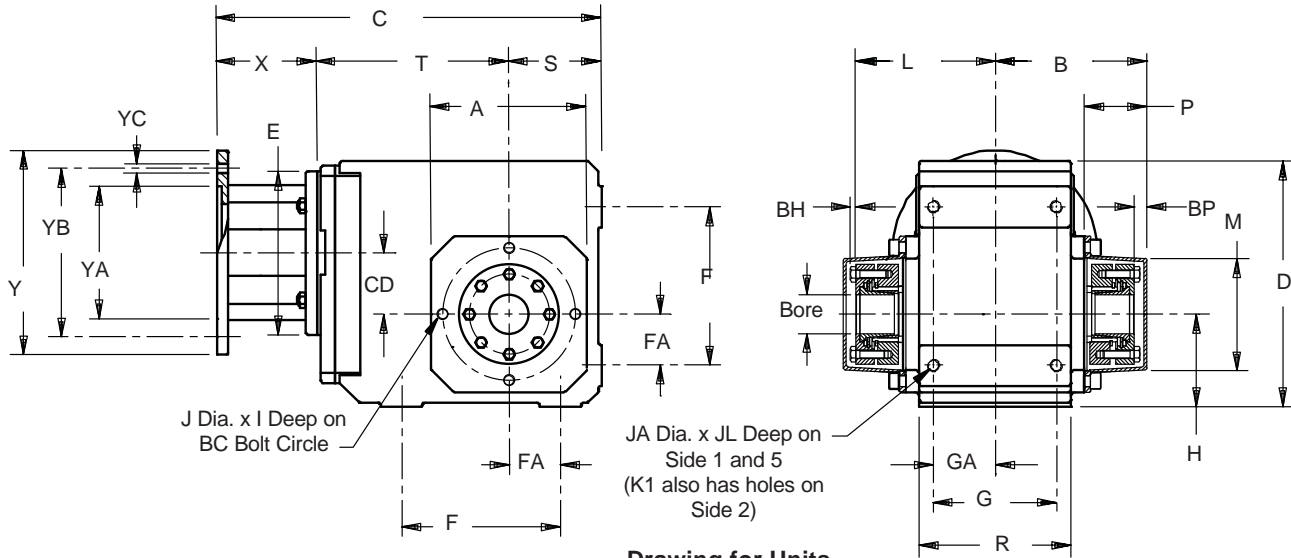

**Drawing for Units  
K102WG – K403WG**

**Table No. 1 Food Duty – "K" Series – Double Wobble Free – Unit Dimensions (Inches)**

Base Module	Max. Bore	A	B	D	F	G	H	I	J	L	M	P	R	S	Z <sub>1</sub>	BC	BP	BH	FA	GA	JA	JL
<b>K102</b>	1.000	4.13	3.90	6.30	3.54	2.76	2.36	.51	M8	3.66	3.07	1.97	3.54	2.36	—	3.54	.24	.16	1.18	1.38	M8	.51
<b>K202/203</b>	1.187	4.57	4.68	7.48	4.53	3.54	2.56	.51	M8	4.26	3.46	2.05	4.53	2.56	—	3.94	.39	.16	1.38	1.77	M10	.63
<b>K302/303</b>	1.500	5.20	4.98	8.39	5.12	4.13	2.95	.51	M8	4.54	3.78	2.09	5.12	2.95	—	4.53	.43	.16	1.57	2.07	M10	.63
<b>K402/403</b>	1.500	5.98	5.80	9.45	6.10	4.72	3.54	.63	M10	5.33	4.33	2.40	5.83	3.54	—	5.12	.47	.20	1.97	2.36	M12	.75
<b>K513/514</b>	2.000	5.71	6.05	10.24	5.51	4.92	6.30	.63	M10	5.61	4.54	2.40	6.30	3.94	5.98	5.12	.43	.20	1.57	2.46	M16	1.02
<b>K613/614</b>	2.187	7.09	6.61	12.20	6.30	5.12	7.48	.63	M10	6.10	5.00	2.68	6.61	4.72	6.77	6.50	.51	.24	1.97	2.56	M16	1.02
<b>K713/714</b>	2.375	7.68	7.68	13.46	7.09	5.71	8.35	.75	M12	7.29	5.75	2.91	7.48	4.92	7.52	7.28	.39	.24	2.17	2.85	M20	1.22
<b>K813/814</b>	2.750	8.90	9.34	16.14	9.45	7.28	10.43	.75	M12	8.70	6.95	3.43	9.25	5.71	8.11	8.46	.64	.31	2.95	3.64	M24	1.50

**Table No. 2 Motor Adapter Dimensions (Inches)**

Motor Adapter	NEMA C-Flange	E	X	Y	YA	YB	YC	Wt. lbs.
<b>MR140/050F</b>	56C	5.51	3.31	6.50	4.500	5.87	.41	9
<b>MR160/050F</b>	56C	6.30	3.86	6.50	4.500	5.87	.41	16
<b>MR160/140F</b>	143/145TC	6.30	3.86	6.50	4.500	5.87	.41	16
<b>MR200/180F</b>	182/184TC	7.87	4.80	9.00	8.500	7.25	.55	23
<b>MR250/180F</b>	182/184TC	9.84	5.31	9.00	8.500	7.25	.55	36
<b>MR250/210F</b>	213/215TC	9.84	5.31	9.00	8.500	7.25	.55	36
<b>MR300/180F</b>	182/184TC	11.81	6.50	9.00	8.500	7.25	.57	75
<b>MR300/210F</b>	213/215TC	11.81	6.50	9.00	8.500	7.25	.57	75
<b>MR300/250F</b>	254/256TC	11.81	6.50	9.00	8.500	7.25	.57	75
<b>MR300/280F</b>	284/286TC	11.81	6.50	11.13	10.500	9.00	.57	75

**Part No. Example**  
Food Duty Unit  
143TC Frame Motor Adapter  
and 1<sup>7</sup>/<sub>16</sub> Bushing Bore  
**K303WG0650 MR160/140F**  
**WFB3-107**

**Table No. 3 "WFB" – Double Side Bushings – Metric**

Unit	Stock Bore Sizes – mm			
	25	30	35	40
<b>K1</b>	<b>WFB1-25</b>	—	—	—
<b>K2</b>	—	<b>WFB2-30</b>	—	—
<b>K3</b>	—	<b>WFB3-30</b>	<b>WFB3-35</b>	—
<b>K4</b>	—	—	—	<b>WFB4-40</b>
<b>K5</b>	—	—	—	<b>WFB5-40</b>
<b>K6</b>	—	—	—	<b>WFB6-40</b>

**Table No. 4 "WFB" Double Side Bushings – Inches**

Unit	Stock Bore Sizes					
	1	1 <sup>3</sup> / <sub>16</sub>	1 <sup>1</sup> / <sub>4</sub>	1 <sup>3</sup> / <sub>8</sub>	1 <sup>7</sup> / <sub>16</sub>	1 <sup>1</sup> / <sub>2</sub>
<b>K1</b>	<b>WFB1-100</b>	—	—	—	—	—
<b>K2</b>	<b>WFB2-100</b>	<b>WFB2-103</b>	—	—	—	—
<b>K3</b>	<b>WFB3-100</b>	<b>WFB3-103</b>	<b>WFB3-104</b>	<b>WFB3-106</b>	<b>WFB3-107</b>	<b>WFB3-108</b>
<b>K4</b>	<b>WFB4-100</b>	<b>WFB4-103</b>	<b>WFB4-104</b>	<b>WFB4-106</b>	<b>WFB4-107</b>	<b>WFB4-108</b>



# Food Duty – "K" Series – MGS Reducer Tapped Hole – "G" Housing Double Bushing – Dimensional Data

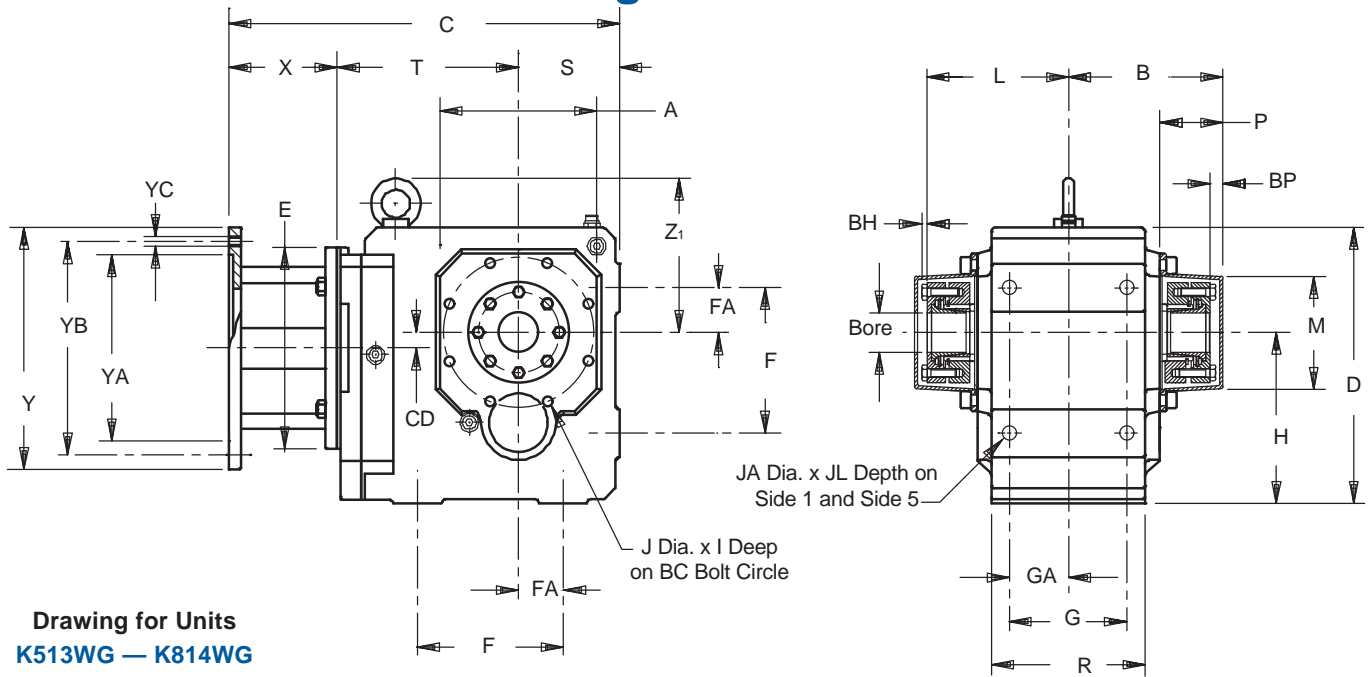
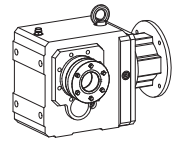

Drawing for Units  
K513WG – K814WG

Table No. 5 Food Duty – "K" Series – Double Wobble Free – Unit Dimensions (Inches)

Base	MR140/050F			MR160/140F <sup>1)</sup>			MR200/180F			MR250/210F <sup>2)</sup>			MR300/250F <sup>3)</sup>			Wt.
Module	CD	C	T	CD	C	T	CD	C	T	CD	C	T	CD	C	T	lbs.
K102	1.42	10.55	4.88	1.42	11.26	5.04	—	—	—	—	—	—	—	—	—	31
K202	1.81	11.50	5.63	1.81	12.21	5.79	1.81	13.23	5.87	—	—	—	—	—	—	40
K203	1.81	12.96	7.09	—	—	—	—	—	—	—	—	—	—	—	—	53
K302	2.07	12.68	6.42	2.07	13.38	6.57	2.07	14.40	6.65	—	—	—	—	—	—	67
K303	2.07	14.13	7.87	.63	15.08	8.27	—	—	—	—	—	—	—	—	—	73
K402	—	—	—	2.36	14.76	7.36	2.36	15.74	7.44	2.36	16.41	7.56	—	—	—	93
K403	2.36	15.51	8.66	.91	16.46	9.06	—	—	—	—	—	—	—	—	—	100
K513	—	—	—	.59	14.57	6.77	.59	15.59	6.85	.59	16.22	6.97	—	—	—	106
K514	—	—	—	.59	16.26	8.46	—	—	—	—	—	—	—	—	—	109
K613	—	—	—	.71	16.10	7.52	.71	17.12	7.60	.71	17.75	7.72	.71	19.49	8.27	170
K614	—	—	—	.71	17.79	9.21	—	—	—	—	—	—	—	—	—	177
K713	—	—	—	—	—	—	.79	18.42	8.70	.79	19.05	8.82	.79	20.75	9.33	221
K714	—	—	—	.79	19.13	10.35	.79	20.86	11.14	—	—	—	—	—	—	234
K813	—	—	—	—	—	—	.94	20.23	9.72	.94	20.82	9.80	.94	22.52	10.31	309
K814	—	—	—	—	—	—	.94	22.64	12.13	—	—	—	—	—	—	331

<sup>1)</sup> Also available as MR160/050F for a NEMA 56C frame motor.

<sup>2)</sup> Also available as MR250/180F for a NEMA 182/184TC frame motor.

<sup>3)</sup> Also available as MR300/180F for NEMA 182/184TC, MR300/210F for NEMA 213/215TC, and MR300/280F for NEMA 284/286TC frame motor.

All weights are approximate.

**NOTE:** A double side bushing kit includes 2 each of a pressure ring and clamp ring, flanged and tapered cone, and all hardware to mount the kit into the reducer. The WFB1 does not use a tapered cone. All double bushing kits include covers. The bushing will accept a shaft with a tolerance of +.000/-.005.

Table No. 6 "WFB" Double Side Bushings – Inches

Unit	Stock Bores Sizes – Inches											
	17/16	1 1/2	1 5/8	1 11/16	1 3/4	1 7/8	1 15/16	2	2 3/16	2 3/8	2 7/16	2 3/4
K5	WFB5-107	WFB5-108	WFB5-110	WFB5-111	WFB5-112	WFB5-114	WFB5-115	WFB5-200	—	—	—	—
K6	WFB6-107	WFB6-108	WFB6-110	WFB6-111	WFB6-112	—	WFB6-115	WFB6-200	WFB6-203	—	—	—
K7	—	—	—	—	—	—	WFB7-115	WFB7-200	WFB7-203	WFB7-206	—	—
K8	—	—	—	—	—	—	—	—	WFB8-203	WFB8-206	WFB7-207	WFB8-212

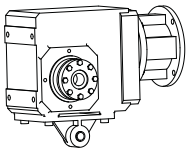

# Food Duty – "K" Series – MGS Reducer Torque Arm Bracket – "GD" Housing Double Bushing – Dimensional Data

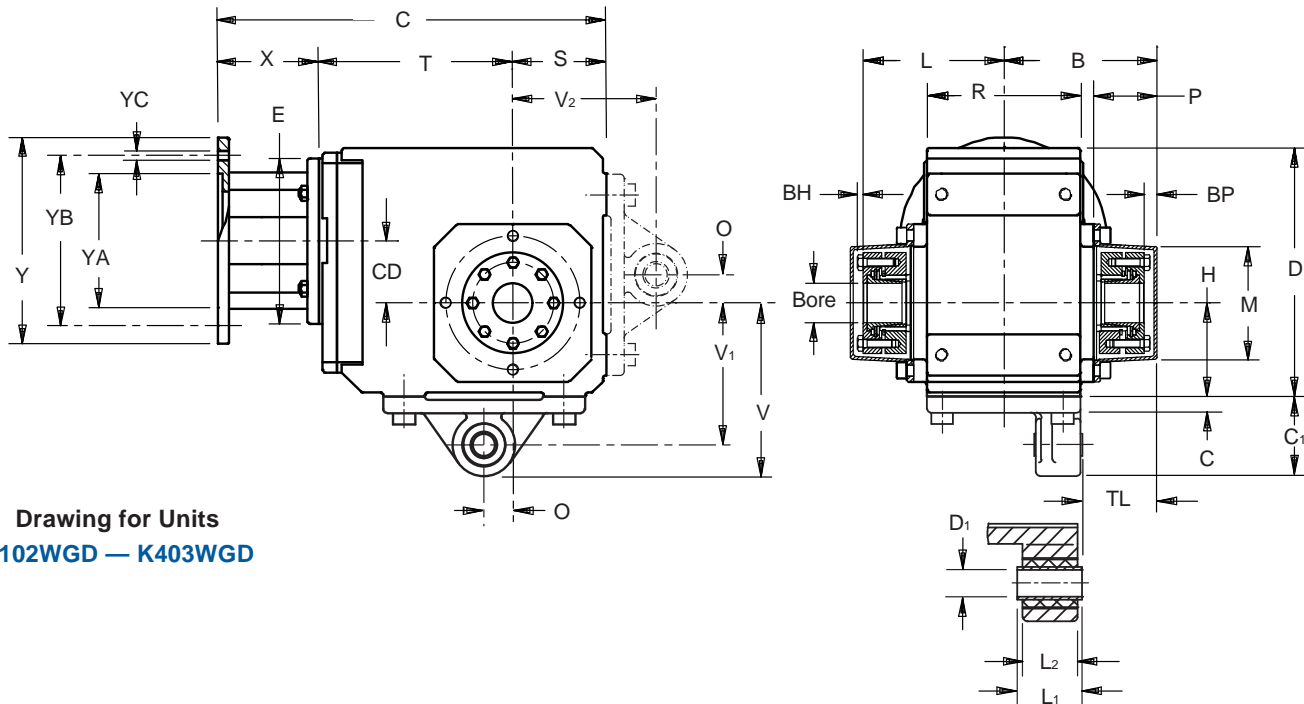

Drawing for Units  
K102WGD – K403WGD

Table No. 1 Food Duty – "K" Series – Double Side Bushing – Unit Dimensions (Inches)

Base Module	B	C	C <sub>1</sub>	D	D <sub>1</sub> H9	H	L	L <sub>1</sub>	L <sub>2</sub>	M	O	P	R	S	V	V <sub>1</sub>	V <sub>2</sub>	Z <sub>1</sub>	BP	BH	TL
<b>K102</b>	3.90	.39	2.03	6.30	.47 +0.017/-0.000	2.36	3.66	1.10	.94	3.07	.59	1.97	3.54	2.36	4.39	3.54	3.54	—	.24	.16	2.05
<b>K202/203</b>	4.68	.47	2.26	7.48	.63 +0.017/-0.000	2.56	4.26	1.50	1.26	3.46	.89	2.05	4.53	2.56	4.82	3.93	3.93	—	.39	.16	2.29
<b>K302/303</b>	4.98	.47	2.66	8.39	.63 +0.017/-0.000	2.95	4.54	1.50	1.26	3.78	.98	2.09	5.12	2.95	5.61	4.72	4.72	—	.43	.16	2.30
<b>K402/403</b>	5.80	.55	3.46	9.45	.79 +0.020/-0.000	3.54	5.33	1.81	1.57	4.33	1.08	2.40	5.83	3.54	7.00	5.91	5.91	—	.47	.20	2.77
<b>K513/514</b>	6.05	.59	4.68	10.24	.79 +0.020/-0.000	6.30	5.61	1.81	1.57	4.54	1.18	2.40	6.30	3.94	10.98	9.84	7.48	5.98	.43	.20	2.78
<b>K613/614</b>	6.61	.59	3.50	12.20	.79 +0.020/-0.000	7.48	6.10	1.81	1.57	5.00	1.18	2.68	6.61	4.72	10.98	9.84	7.09	6.77	.51	.24	3.16
<b>K713/714</b>	7.68	.67	4.80	13.46	.79 +0.020/-0.000	8.35	7.29	2.76	2.52	5.75	1.38	2.91	7.48	4.92	13.15	11.81	8.39	7.52	.39	.24	3.82
<b>K813/814</b>	9.34	.67	4.77	16.14	.94 +0.020/-0.000	10.43	8.70	4.53	4.02	6.95	1.77	3.43	9.25	5.71	15.20	13.78	9.06	8.11	.64	.31	4.45

Table No. 2 Motor Adapter Dimensions (Inches)

Motor Adapter	NEMA C-Flange	E	X	Y	YA	YB	YC	Wt. lbs.
<b>MR140/050F</b>	56C	5.51	3.31	6.50	4.500	5.87	.41	9
<b>MR160/050F</b>	56C	6.30	3.86	6.50	4.500	5.87	.41	16
<b>MR160/140F</b>	143/145TC	6.30	3.86	6.50	4.500	5.87	.41	16
<b>MR200/180F</b>	182/184TC	7.87	4.80	9.00	8.500	7.25	.55	23
<b>MR250/180F</b>	182/184TC	9.84	5.31	9.00	8.500	7.25	.55	36
<b>MR250/210F</b>	213/215TC	9.84	5.31	9.00	8.500	7.25	.55	36
<b>MR300/180F</b>	182/184TC	11.81	6.50	9.00	8.500	7.25	.57	75
<b>MR300/210F</b>	213/215TC	11.81	6.50	9.00	8.500	7.25	.57	75
<b>MR300/250F</b>	254/256TC	11.81	6.50	9.00	8.500	7.25	.57	75
<b>MR300/280F</b>	284/286TC	11.81	6.50	11.13	10.500	9.00	.57	75

**Part No. Example**  
Food Duty Unit with Torque Arm Bracket  
143TC Frame Motor Adapter  
and 1/16" Bushing Bore  
**K303WGD0650 MR160/140F**  
**WFB3-107**

Table No. 3 "WFB" – Double Side Bushings – Metric

Unit	Stock Bores Sizes – mm			
	25	30	35	40
<b>K1</b>	<b>WFB1-25</b>	—	—	—
<b>K2</b>	—	<b>WFB2-30</b>	—	—
<b>K3</b>	—	<b>WFB3-30</b>	<b>WFB3-35</b>	—
<b>K4</b>	—	—	—	<b>WFB4-40</b>
<b>K5</b>	—	—	—	<b>WFB5-40</b>
<b>K6</b>	—	—	—	<b>WFB6-40</b>

Table No. 4 "WFB" Double Side Bushings – Inches

Unit	Stock Bores Sizes					
	1	1 <sup>3</sup> / <sub>16</sub>	1 <sup>1</sup> / <sub>4</sub>	1 <sup>3</sup> / <sub>8</sub>	1 <sup>7</sup> / <sub>16</sub>	1 <sup>1</sup> / <sub>2</sub>
<b>K1</b>	<b>WFB1-100</b>	—	—	—	—	—
<b>K2</b>	<b>WFB2-100</b>	<b>WFB2-103</b>	—	—	—	—
<b>K3</b>	<b>WFB3-100</b>	<b>WFB3-103</b>	<b>WFB3-104</b>	<b>WFB3-106</b>	<b>WFB3-107</b>	<b>WFB3-108</b>
<b>K4</b>	<b>WFB4-100</b>	<b>WFB4-103</b>	<b>WFB4-104</b>	<b>WFB4-106</b>	<b>WFB4-107</b>	<b>WFB4-108</b>





# Food Duty – "K" Series – MGS Reducer Torque Arm Bracket – "GD" Housing Double Bushing – Dimensional Data

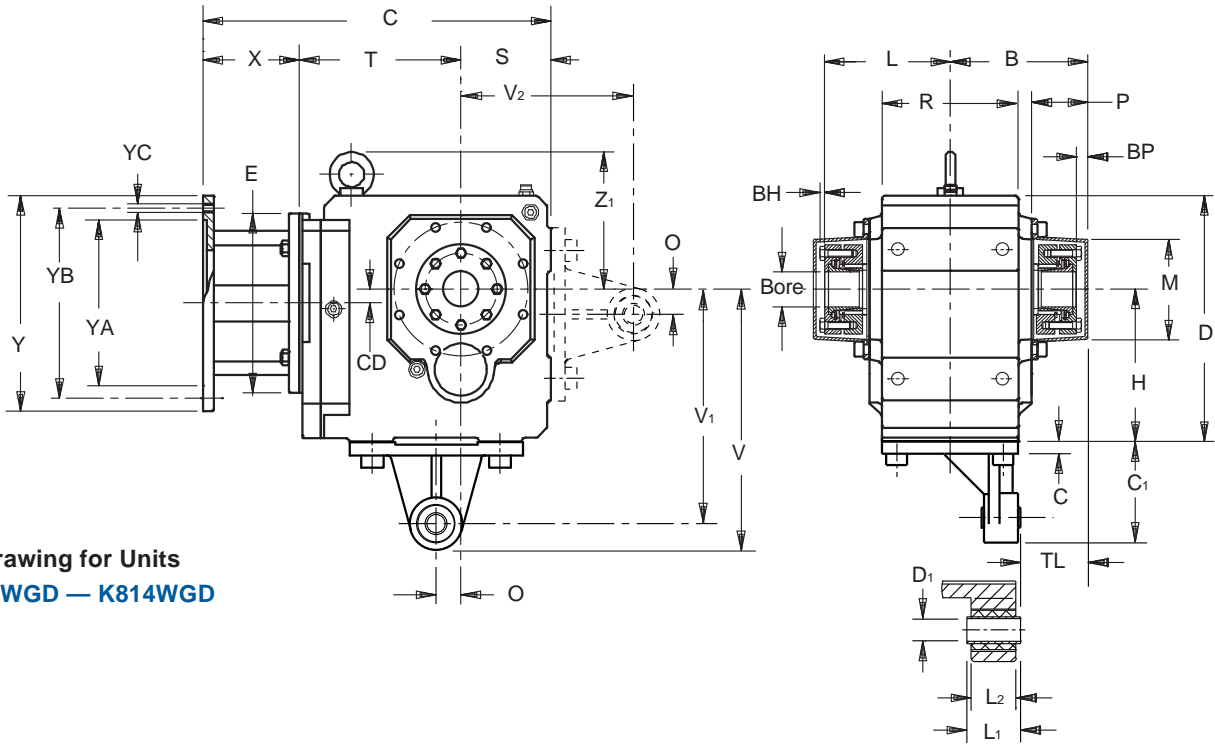
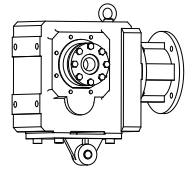

Drawing for Units  
K513WGD – K814WGD

Table No. 5 Food Duty – "K" Series – Unit Dimensions (Inches)

Base Module	MR140/050F			MR160/140F <sup>1)</sup>			MR200/180F			MR250/210F <sup>2)</sup>			MR300/250F <sup>3)</sup>			Wt. lbs.
	CD	C	T	CD	C	T	CD	C	T	CD	C	T	CD	C	T	
K102	1.42	10.55	4.88	1.42	11.26	5.04	—	—	—	—	—	—	—	—	—	31
K202	1.81	11.50	5.63	1.81	12.21	5.79	1.81	13.23	5.87	—	—	—	—	—	—	40
K203	1.81	12.96	7.09	—	—	—	—	—	—	—	—	—	—	—	—	53
K302	2.07	12.68	6.42	2.07	13.38	6.57	2.07	14.40	6.65	—	—	—	—	—	—	67
K303	2.07	14.13	7.87	.63	15.08	8.27	—	—	—	—	—	—	—	—	—	73
K402	—	—	—	2.36	14.76	7.36	2.36	15.74	7.44	2.36	16.41	7.56	—	—	—	93
K403	2.36	15.51	8.66	.91	16.46	9.06	—	—	—	—	—	—	—	—	—	100
K513	—	—	—	.59	14.57	6.77	.59	15.59	6.85	.59	16.22	6.97	—	—	—	106
K514	—	—	—	.59	16.26	8.46	—	—	—	—	—	—	—	—	—	109
K613	—	—	—	.71	16.10	7.52	.71	17.12	7.60	.71	17.75	7.72	.71	19.49	8.27	170
K614	—	—	—	.71	17.79	9.21	—	—	—	—	—	—	—	—	—	177
K713	—	—	—	—	—	—	.79	18.42	8.70	.79	19.05	8.82	.79	20.75	9.33	221
K714	—	—	—	.79	19.13	10.35	.79	20.86	11.14	—	—	—	—	—	—	234
K813	—	—	—	—	—	—	.94	20.23	9.72	.94	20.82	9.80	.94	22.52	10.31	309
K814	—	—	—	—	—	—	.94	22.64	12.13	—	—	—	—	—	—	331

<sup>1)</sup> Also available as MR160/050F for a NEMA 56C frame motor.

<sup>2)</sup> Also available as MR250/180F for a NEMA 182/184TC frame motor.

<sup>3)</sup> Also available as MR300/180F for NEMA 182/184TC, MR300/210F for NEMA 213/215TC, and MR300/280F for NEMA 284/286TC frame motor. All weights are approximate.

**NOTE:** A double side bushing kit includes 2 each of a pressure ring and clamp ring, flanged and tapered cone, and all hardware to mount the kit into the reducer. The WFB1 does not use a tapered cone. All double bushing kits include covers. The bushing will accept a shaft with a tolerance of +.000/-.005.

Table No. 6 "WFB" Double Side Bushings – Inches

Unit	Stock Bores Sizes – Inches											
	17/16	1 1/2	1 5/8	1 11/16	1 3/4	1 7/8	1 15/16	2	2 3/16	2 3/8	2 7/16	2 3/4
K5	WFB5-107	WFB5-108	WFB5-110	WFB5-111	WFB5-112	WFB5-114	WFB5-115	WFB5-200	—	—	—	—
K6	WFB6-107	WFB6-108	WFB6-110	WFB6-111	WFB6-112	—	WFB6-115	WFB6-200	WFB6-203	—	—	—
K7	—	—	—	—	—	—	WFB7-115	WFB7-200	WFB7-203	WFB7-206	—	—
K8	—	—	—	—	—	—	—	—	WFB8-203	WFB8-206	WFB7-207	WFB8-212

# Food Duty – "F" Series – MGS Reducer Offset Helical with Hollow Output



## Reducer Configurations

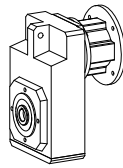

Style AG

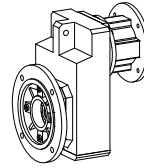

Style AF

## Mounting Positions – Standard 3 Year Warranty

One Standard Unit for ALL Horizontal Mounting Positions Without Changing the Oil Level

Standard Oil: Mobile XP600

Optional Oil: Food Grade Oil (Exxon Univas Special Mist 220)  
Synthetic Oil (Mobil SHC630)

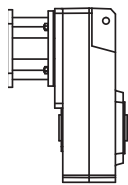

EL1

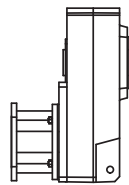

EL2

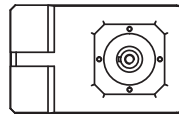

EL3

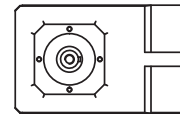

EL4

## Mounting Positions – Long Life 5 Year Warranty

Mounting Positions **MUST BE SPECIFIED.**

Standard Oil: Synthetic Oil (Mobil SHC630)

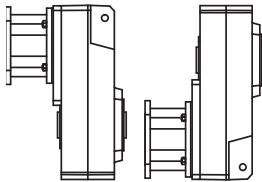

E12

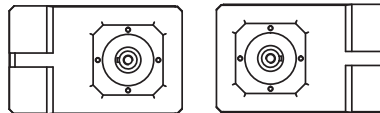

E34

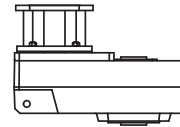

E15

## Part No. Explanation with OPTIONS

**F 2 0 2 A F 0135 MR200/ 180 F LL E12**

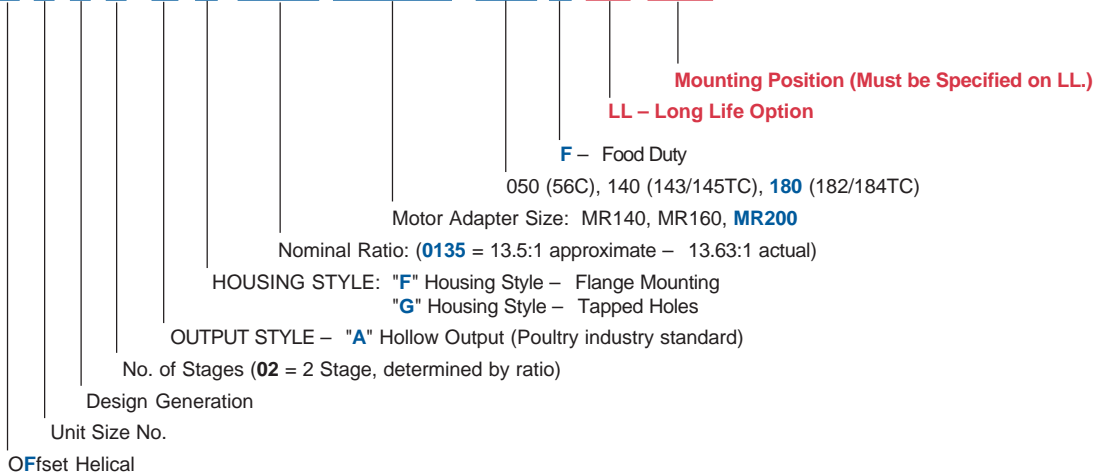

### THE FOLLOWING ARE OPTIONS FOR ANY UNIT:

- Paint – White
- Oil – Food Grade, Synthetic



# Food Duty – "F" Series – MGS Reducer Offset Helical with Hollow Output

- Lubricated for Life
- Maintenance Free
- Totally Enclosed (No Vent Required)
- 3 Year Warranty – your guarantee of our confidence in the MGS (Modular Gear System) line of reducers
- 97% Efficiency – for high quality and reliability plus cost savings in energy and maintenance



- Standard Coating –
- 1, Primer
  - 2, Industrial 316 Stainless Steel Epoxy
  - 1, Silver Bullet Anti-Microbial™ Epoxy

Stainless Steel Nameplate

NEMA C-face Input –  
O-ring between motor and reducer  
with an easy mount, maintenance  
free coupling

Double Sealed Output – with a  
dual lip outer seal and a single lip  
inner seal

Stainless Steel Output Quill



Outside Cover Cap – protects seals  
from high pressure washing



F Series Food Duty hollow output units  
have bore sizes designed specifically for  
the poultry industry.

**See Pages 102-109 for Selection Data.**

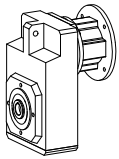

# Food Duty – "F" Series – MGS Reducer Tapped Hole – "G" Housing Hollow Output – Dimensional Data

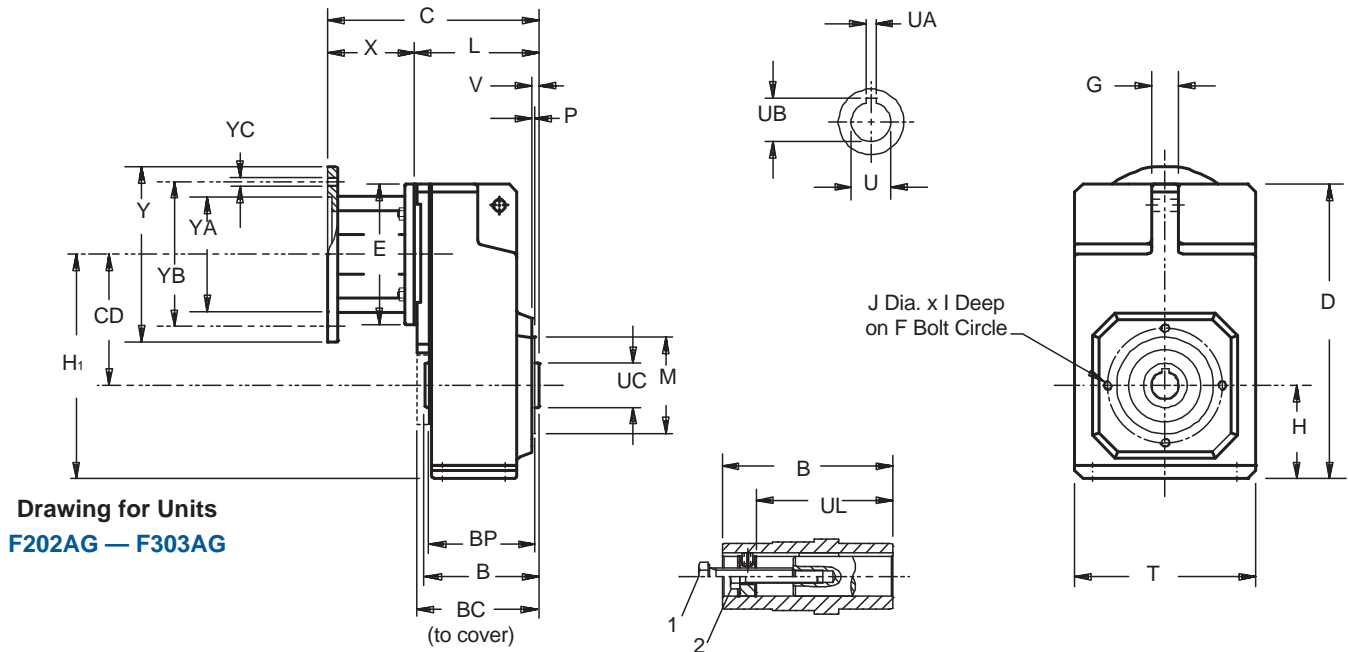

**Table No. 1 Food Duty "F" Series – Unit Dimensions (Inches) – "G" Housing Style**

Base Module	CD	B	D	F	G	H	H <sub>1</sub>	I	J	M	P	T	U	V	BC	BP	UA	UB	UC	UL	1
<b>F202/F203</b>	5.16	4.53	11.77	4.53	.87	3.66	8.82	.51	M8	3.740	.12	7.09	1.000	.31	4.76	4.13	.250	1.12	1.77	3.62	1/2-13
<b>F302/F303</b>	5.89	5.12	13.23	5.12	1.18	4.17	10.06	.63	M10	4.331	.14	8.11	1.250	.33	5.45	4.72	.250	1.37	1.97	4.06	1/2-13

**Table No. 2 Food Duty "F" Series – Unit Dimensions (Inches)**

Motor Adapter	NEMA C-Flange	E	X	Y	YA	YB	YC	Wt. lbs.
<b>MR140/050F</b>	56C	5.51	3.31	6.50	4.500	5.87	.41	9
<b>MR160/050F</b>	56C	6.30	3.86	6.50	4.500	5.87	.41	16
<b>MR160/140F</b>	143/145TC	6.30	3.86	6.50	4.500	5.87	.41	16
<b>MR200/180F</b>	182/184TC	7.87	4.80	9.00	8.500	7.25	.55	23

**Table No. 3 "F" Series Unit Dimensions (Inches)**

Base Module	MR140/050F		MR160/140F <sup>1)</sup>		MR200/180F		Approx. Wt. lbs.
	C	L	C	L	C	L	
<b>F202</b>	8.15	4.84	8.86	5.00	9.88	5.08	51
<b>F203</b>	9.61	6.30	—	—	—	—	64
<b>F302</b>	8.74	5.43	9.45	5.59	10.47	5.67	67
<b>F303</b>	10.20	6.89	—	—	—	—	73

<sup>1)</sup> Also available as **MR160/050F** for a NEMA 56C frame motor.

### Part No. Example

Food Duty Unit  
Tapped Hole Housing with Motor Adapter  
**F302AG0560 MR160/140F**

1. Removal Bolt —not supplied.
  2. Mounting Bolt —must be smaller than removal bolt.
- All weights are approximate.

### Rubber Buffer for Torque Arm Mounting

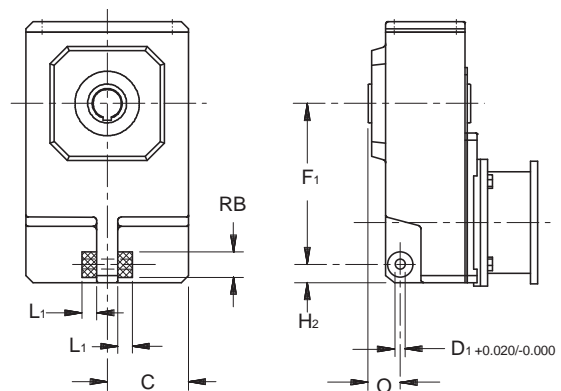

**Table No. 4**

Base Module	Part No.
F2	<b>25192</b>
F3	<b>25193</b>

Order two (2) rubber buffers for each unit.  
Torque arms are not supplied by STÖBER.





# Food Duty – "F" Series – MGS Reducer Round Flange – "F" Housing Hollow Output – Dimensional Data

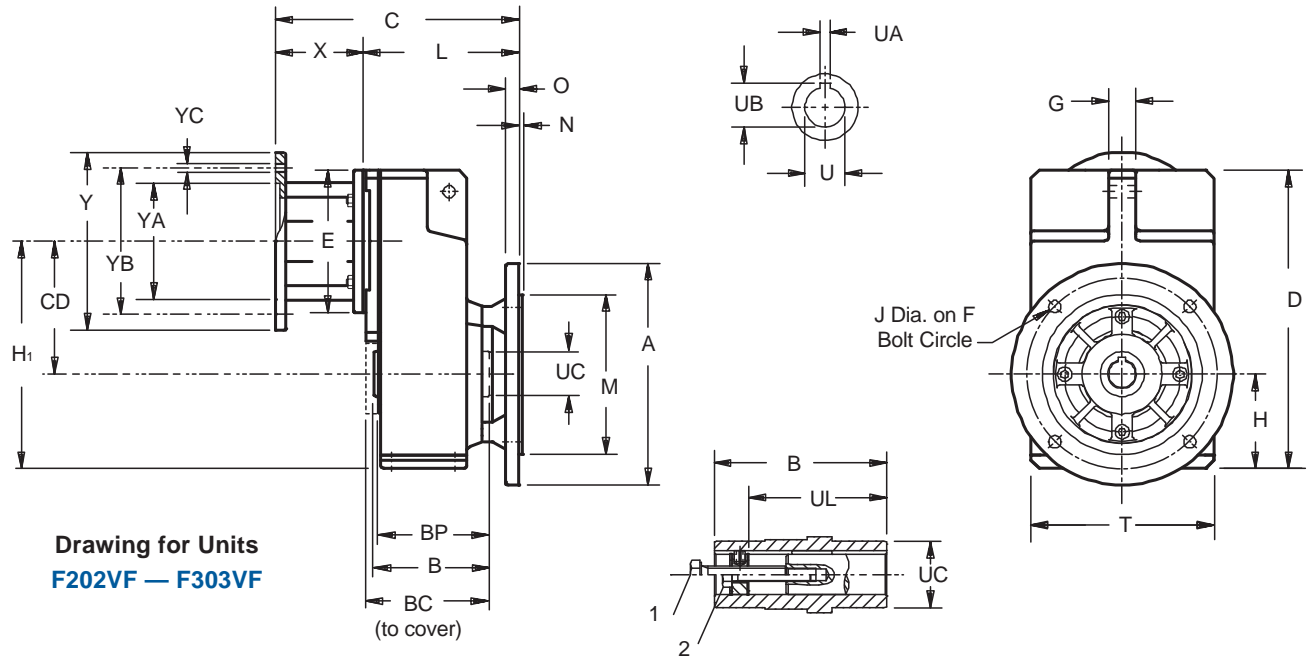
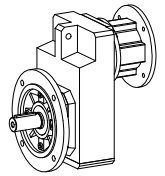

**Table No. 1 Food Duty "F" Series – Round Flange Dimensions (Inches)**

Base Module	CD	A	B	D	F	G	H	H <sub>1</sub>	J	M	N	O	T	U	BC	BP	UA	UB	UC	UL	1
<b>F202/F203</b>	5.16	7.87	4.53	11.77	6.50	.87	3.66	8.82	.43	5.118	.14	.55	7.09	1.000	4.76	4.13	.250	1.12	1.77	3.62	1/2-13
<b>F302/F303</b>	5.89	9.84	5.12	13.23	8.46	1.18	4.17	10.06	.55	7.087	.16	.59	8.11	1.250	5.5	4.72	.250	1.37	1.97	4.06	1/2-13

**Table No. 2**

**Food Duty "F" Series – Unit Dimensions (Inches) – "G" Housing Style**

Motor Adapter	NEMA C-Flange	E	X	Y	YA	YB	YC	Wt. lbs.
<b>MR140/050F</b>	56C	5.51	3.31	6.50	4.500	5.87	.41	9
<b>MR160/050F</b>	56C	6.30	3.86	6.50	4.500	5.87	.41	16
<b>MR160/140F</b>	143/145TC	6.30	3.86	6.50	4.500	5.87	.41	16
<b>MR200/180F</b>	182/184TC	7.87	4.80	9.00	8.500	7.25	.55	23

**Table No. 3 "F" Series Unit Dimensions (Inches)**

Base Module	MR140/050F		MR160/140F <sup>1)</sup>		MR200/180F		Approx. Wt. lbs.
	C	L	C	L	C	L	
<b>F202</b>	11.54	6.03	12.48	6.18	14.13	6.26	51
<b>F203</b>	12.99	7.48	—	—	—	—	64
<b>F302</b>	12.20	6.69	13.15	6.85	14.80	6.93	67
<b>F303</b>	13.66	8.15	—	—	—	—	73

<sup>1)</sup> Also available as **MR160/050F** for a NEMA 56C frame motor.

1. Removal Bolt —not supplied.
  2. Mounting Bolt —must be smaller than removal bolt.
- All weights are approximate.

**Part No. Example**  
Food Duty Unit  
Output Flange with Motor Adapter  
**F302AF0560 MR160/140F**

# Food Duty – "C" Series – MGS Reducers Concentric Helical



## Reducer Configurations

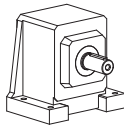

Style N  
Foot Mount

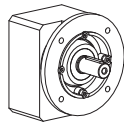

Style F  
Round Flange

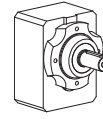

Style G  
Tapped Holes

## Mounting Positions – Standard 3 Year Warranty

One Standard Unit for ALL Horizontal Mounting Positions Without Changing the Oil Level

Standard Oil: Mobile XP600

Optional Oil: Food Grade Oil (Exxon Univis Special Mist 220)

Synthetic Oil (Mobil SHC630)

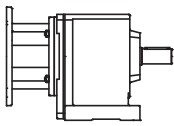

EL1

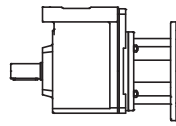

EL2

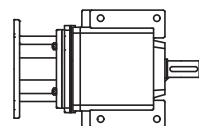

EL3

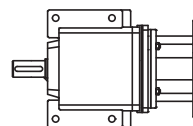

EL4

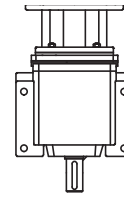

EL5

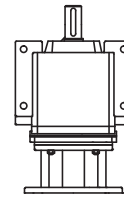

EL6

EL5 and EL6 can be supplied on request.

EL6 is possible but not recommended.

## Mounting Positions – Long Life 5 Year Warranty

Mounting Positions **MUST BE SPECIFIED**

Standard Oil: Synthetic Oil (Mobil SHC630)

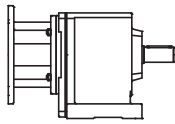

EL12

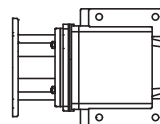
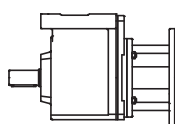

EL34

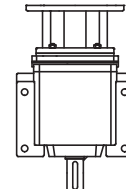
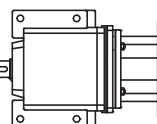

EL5

## Part No. Explanation with OPTIONS

**C 4 0 2 N 0135 MR160 / 140 F LL E34**

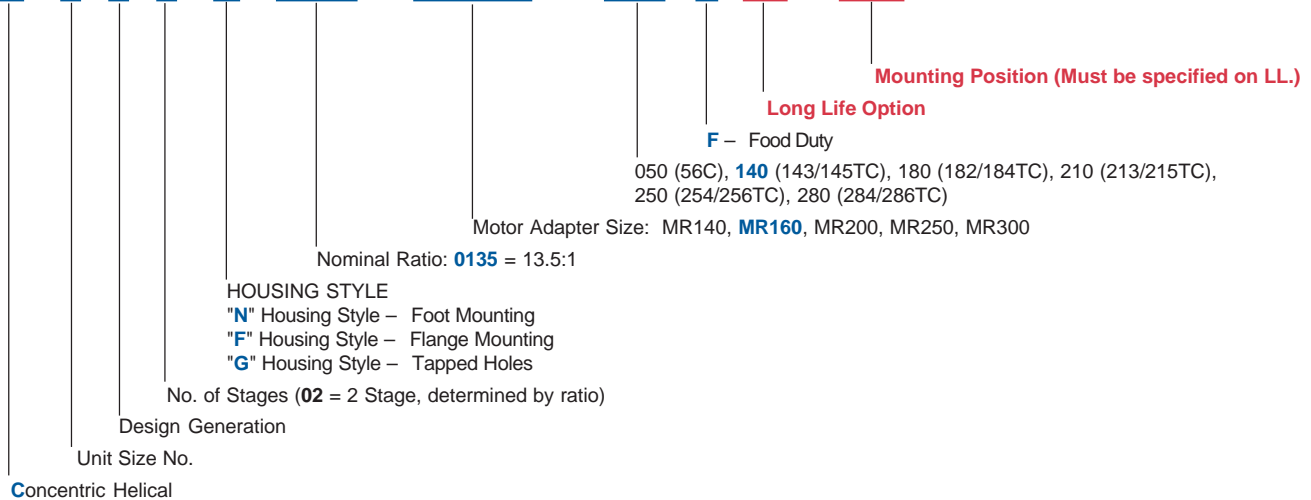

THE FOLLOWING ARE OPTIONS FOR ALL UNITS:

- Paint – White
- Oil – Food Grade, Synthetic



# Food Duty – "C" Series – MGS Reducers Concentric Helical

- Lubricated for Life
- Maintenance Free
- Totally Enclosed (Watertight)
- 3 Year Warranty – your guarantee of our confidence in the MGS (Modular Gear System) line of reducers
- 97% Efficiency – for high quality and reliability plus cost savings in energy and maintenance



- Standard Coating – 1, Primer  
 – 2, Industrial 316 Stainless Steel Epoxy  
 – 1, Silver Bullet Anti-Microbial™ Epoxy

Stainless Steel  
Nameplate

- NEMA C-face Input
- O-ring between motor and reducer
  - Easy mount maintenance free coupling



Stainless Steel Output Shaft and Key

Double Sealed Output – with a dual lip outer seal and a single lip inner seal

**See Pages 64-91 for Selection Data.**

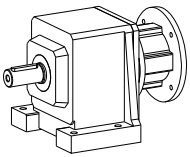

# Food Duty – "C" Series – MGS Reducer Foot Mount – "N" Housing Dimensional Data

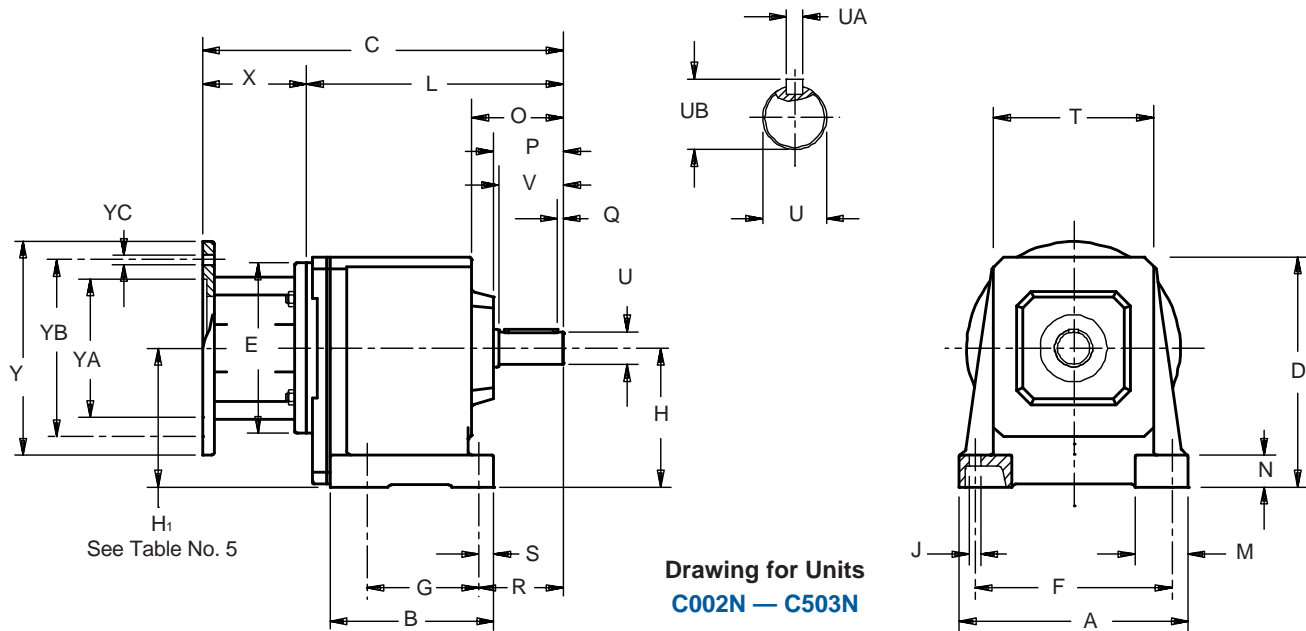

**Table No. 1 "C" Series – Foot Mounting Unit Dimensions (Inches) – "N" Housing Style**

Base Module	A	B	D	F	G	H	J	M	N	O	P	Q	R
<b>C002</b>	5.20	3.74	5.67	4.33	2.44	3.23	.28	1.38	.79	2.24	1.73	.16	2.17
<b>C102/C103</b>	6.93	4.65	6.97	5.91	2.76	4.02	.35	1.65	.98	2.72	2.13	.16	2.64
<b>C202/C203</b>	7.87	5.31	7.68	6.69	3.35	4.53	.43	1.97	1.18	3.39	2.56	.16	3.11
<b>C302/C303</b>	8.46	6.06	8.46	7.28	4.13	5.12 <sup>1)</sup>	.43	1.97	1.18	3.35	2.56	.16	3.11
<b>C402/C403</b>	10.04	7.09	9.65	8.66	4.33	5.71	.55	2.36	1.38	4.17	3.39	.16	4.13
<b>C502/C503</b>	11.42	7.76	11.42	9.65	5.12	6.69	.71	2.76	1.57	4.21	3.39	.16	4.25
<b>C612/C613</b>	11.81	10.43	12.40	9.65	8.46	7.87 <sup>1)</sup>	.71	2.95	1.57	6.02	4.17	.20	5.12

<sup>1)</sup> See Table 5.

**Table No. 2**

Base Module	S	T	U	V	Z <sub>1</sub>	UA – Key	UB
<b>C002</b>	.43	3.62	.7500	1.57	—	$\frac{3}{16} \times \frac{3}{16} \times \frac{17}{32}$	.83
<b>C102/C103</b>	.51	4.88	1.0000	1.97	—	$\frac{1}{4} \times \frac{1}{4} \times \frac{19}{16}$	1.11
<b>C202/C203</b>	.55	5.43	1.2500	2.36	—	$\frac{1}{4} \times \frac{1}{4} \times \frac{15}{16}$	1.36
<b>C302/C303</b>	.55	5.91	1.2500	2.36	—	$\frac{1}{4} \times \frac{1}{4} \times \frac{15}{16}$	1.36
<b>C402/C403</b>	.75	6.89	1.6250	3.15	—	$\frac{3}{8} \times \frac{3}{8} \times \frac{27}{8}$	1.79
<b>C502/C503</b>	.87	7.56	1.6250	3.15	—	$\frac{3}{8} \times \frac{3}{8} \times \frac{27}{8}$	1.79
<b>C612/C613</b>	.98	6.97	2.1250	3.94	6.57	$\frac{1}{2} \times \frac{1}{2} \times \frac{35}{32}$	2.35

**Table No. 3**

**"C" Series – Foot Mounting Unit Dimensions (Inches) – "N" Housing Style**

Motor Adapter	NEMA C-Flange	E	X	Y	YA	YB	YC	Wt. lbs.
<b>MR140/050F</b>	56C	5.51	3.31	6.50	4.500	5.87	.41	9
<b>MR160/050F</b>	56C	6.30	3.86	6.50	4.500	5.87	.41	16
<b>MR160/140F</b>	143/145TC	6.30	3.86	6.50	4.500	5.87	.41	16
<b>MR200/180F</b>	182/184TC	7.87	4.80	9.00	8.500	7.25	.55	23
<b>MR250/180F</b>	182/184TC	9.84	5.31	9.00	8.500	7.25	.55	36
<b>MR250/210F</b>	213/215TC	9.84	5.31	9.00	8.500	7.25	.55	36
<b>MR300/180F</b>	182/184TC	11.81	6.50	9.00	8.500	7.25	.57	75
<b>MR300/210F</b>	213/215TC	11.81	6.50	9.00	8.500	7.25	.57	75
<b>MR300/250F</b>	254/256TC	11.81	6.50	9.00	8.500	7.25	.57	75
<b>MR300/280F</b>	284/286TC	11.81	6.50	11.13	10.500	9.00	.57	75





# Food Duty – "C" Series – MGS Reducer Foot Mount – "N" Housing Dimensional Data

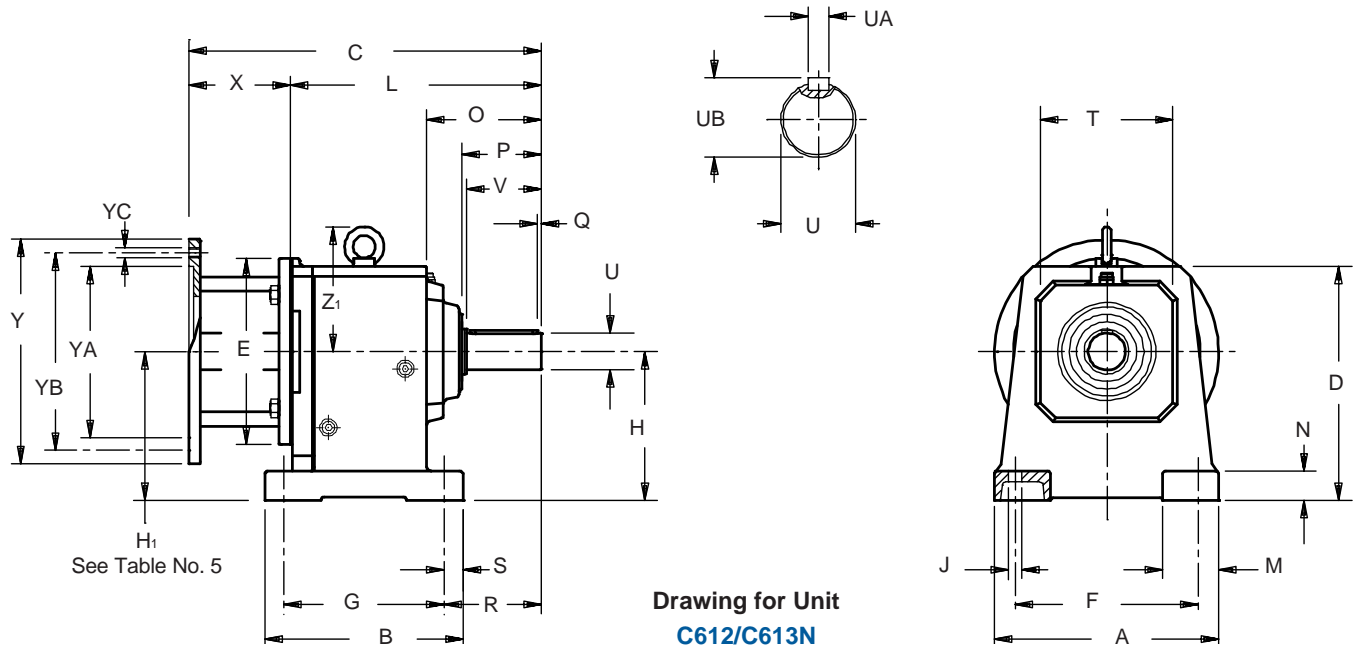
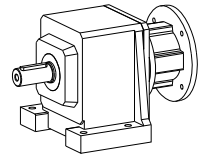

**Table No. 4 "C" Series – Foot Mounting Unit Dimensions (Inches) – "N" Housing Style**

Base Module	MR140/050F		MR160/140F <sup>2)</sup>		MR200/180F		MR250/210F <sup>3)</sup>		MR300/250F <sup>4)</sup>		Approx. Wt.(lbs.)
	C	L	C	L	C	L	C	L	C	L	
<b>C002</b>	9.37	6.06	10.08	6.22	—	—	—	—	—	—	18
<b>C102</b>	10.67	7.36	11.38	7.52	12.40	7.60	—	—	—	—	29
<b>C103</b>	12.13	8.82	—	—	—	—	—	—	—	—	34
<b>C202</b>	11.77	8.46	12.48	8.62	13.50	8.70	—	—	—	—	38
<b>C203</b>	13.23	9.92	14.17	10.31	—	—	—	—	—	—	45
<b>C302</b>	—	—	13.23	9.37	14.25	9.45	14.88	9.57	—	—	49
<b>C303</b>	13.98	10.67	14.92	11.06	—	—	—	—	—	—	56
<b>C402</b>	—	—	15.12	11.26	16.14	11.34	16.77	11.46	—	—	71
<b>C403</b>	—	—	16.81	12.95	—	—	—	—	—	—	78
<b>C502</b>	—	—	15.95	12.09	16.97	12.17	17.59	12.28	19.33	12.83	95
<b>C503</b>	—	—	17.64	13.78	—	—	—	—	—	—	111
<b>C612</b>	—	—	—	—	17.91	13.11	18.54	13.23	20.24	13.74	115
<b>C613</b>	—	—	18.62	14.76	20.35	15.55	—	—	—	—	159

<sup>2)</sup> Also available as **MR160/050F** for a NEMA 56C frame motor. "H" dimension on the input side of a C303 with an MR160/050 or MR160/140 is 3.66.  
<sup>3)</sup> Also available as **MR250/180F** for a NEMA 182/184TC frame motor.  
<sup>4)</sup> Also available as **MR300/180F** for a NEMA 182/184TC, **MR300/210F** for a NEMA 213/215TC, and **MR300/280F** for a NEMA 284/286TC frame motor.  
 All weights are approximate.

**Table No. 5 "C" Series – Input Dimension (Inches)**

Base Module	MR160/050F <sup>2)</sup>	MR200/180F	MR250/210F	MR300/250F
	H <sub>1</sub>	H <sub>1</sub>	H <sub>1</sub>	H <sub>1</sub>
<b>C303</b>	3.66	—	—	—
<b>C612</b>	—	7.63	7.63	7.63
<b>C613</b>	—	—	7.63	—

**Part No. Example**  
 Food Duty Unit  
 Foot Mounting with Motor Adapter  
**C302N0620 MR160/140F**



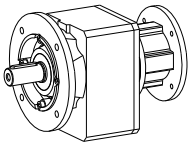

# Food Duty – "C" Series – MGS Reducer Round Flange – "F" Housing Dimensional Data

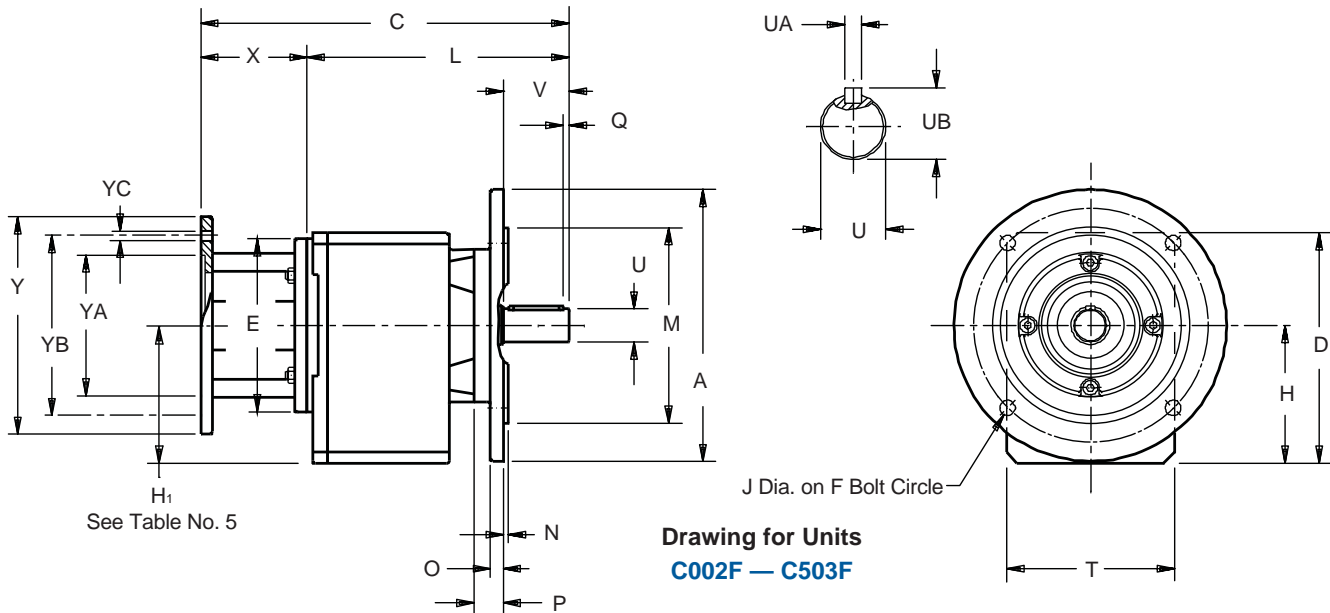

**Drawing for Units  
C002F – C503F**

**Table No. 1 "C" Series – Round Flange Unit Dimensions (Inches) – "F" Housing Style**

Base Module	A	D	F	H	J	M	N	O	P	Q	T	V	Z <sub>1</sub>
<b>C002</b>	6.30	5.55	5.12	3.11	.35	4.331	.12	.39	.71	.16	3.82	1.57	—
<b>C102/C103</b>	7.87	6.89	6.50	3.94	.43	5.118	.14	.47	.83	.16	5.12	1.97	—
<b>C202/C203</b>	7.87	7.56	6.50	4.41	.43	5.118	.14	.47	1.06	.16	5.59	2.36	—
<b>C302/C303</b>	9.84	8.35	8.46	5.00 <sup>1)</sup>	.55	7.087	.16	.47	1.06	.16	6.06	2.36	—
<b>C402/C403</b>	9.84	9.55	8.46	5.61	.55	7.087	.16	.55	1.10	.16	7.01	3.15	—
<b>C502/C503</b>	11.81	11.26	10.43	6.54	.55	9.055	.16	.63	1.14	.16	7.68	3.15	—
<b>C612/C613</b>	11.81	11.97	10.43	7.44 <sup>1)</sup>	.55	9.055	.16	.67	1.42	.20	8.86	3.94	6.57

<sup>1)</sup> See Table No. 5

**Table No. 2**

Base Module	Standard Shaft - inches		
	U	UA	UB
<b>C002</b>	.750	$\frac{3}{16} \times \frac{3}{16} \times 1\frac{17}{32}$	.83
<b>C102/C103</b>	1.000	$\frac{1}{4} \times \frac{1}{4} \times 1\frac{9}{16}$	1.11
<b>C202/C203</b>	1.250	$\frac{1}{4} \times \frac{1}{4} \times 1\frac{15}{16}$	1.36
<b>C302/C303</b>	1.250	$\frac{1}{4} \times \frac{1}{4} \times 1\frac{15}{16}$	1.36
<b>C402/C403</b>	1.625	$\frac{3}{8} \times \frac{3}{8} \times 2\frac{7}{8}$	1.79
<b>C502/C503</b>	1.625	$\frac{3}{8} \times \frac{3}{8} \times 2\frac{7}{8}$	1.79
<b>C612/C613</b>	2.125	$\frac{1}{2} \times \frac{1}{2} \times 3\frac{5}{32}$	2.35

**Table No. 3 Motor Adapter Dimensions (Inches)**

Motor Adapter	NEMA C-Flange	E	X	Y	YA	YB	YC	Wt. lbs.
<b>MR140/050F</b>	56C	5.51	3.31	6.50	4.500	5.87	.41	9
<b>MR160/050F</b>	56C	6.30	3.86	6.50	4.500	5.87	.41	16
<b>MR160/140F</b>	143/145TC	6.30	3.86	6.50	4.500	5.87	.41	16
<b>MR200/180F</b>	182/184TC	7.87	4.80	9.00	8.500	7.25	.55	23
<b>MR250/180F</b>	182/184TC	9.84	5.31	9.00	8.500	7.25	.55	36
<b>MR250/210F</b>	213/215TC	9.84	5.31	9.00	8.500	7.25	.55	36
<b>MR300/180F</b>	182/184TC	11.81	6.50	9.00	8.500	7.25	.57	75
<b>MR300/210F</b>	213/215TC	11.81	6.50	9.00	8.500	7.25	.57	75
<b>MR300/250F</b>	254/256TC	11.81	6.50	9.00	8.500	7.25	.57	75
<b>MR300/280F</b>	284/286TC	11.81	6.50	11.13	10.500	9.00	.57	75

**Part No. Example**  
Food Duty Unit  
Round Flange with Motor Adapter  
**C302F0620 MR160/140F**



# Food Duty – "C" Series – MGS Reducer Round Flange – "F" Housing Dimensional Data

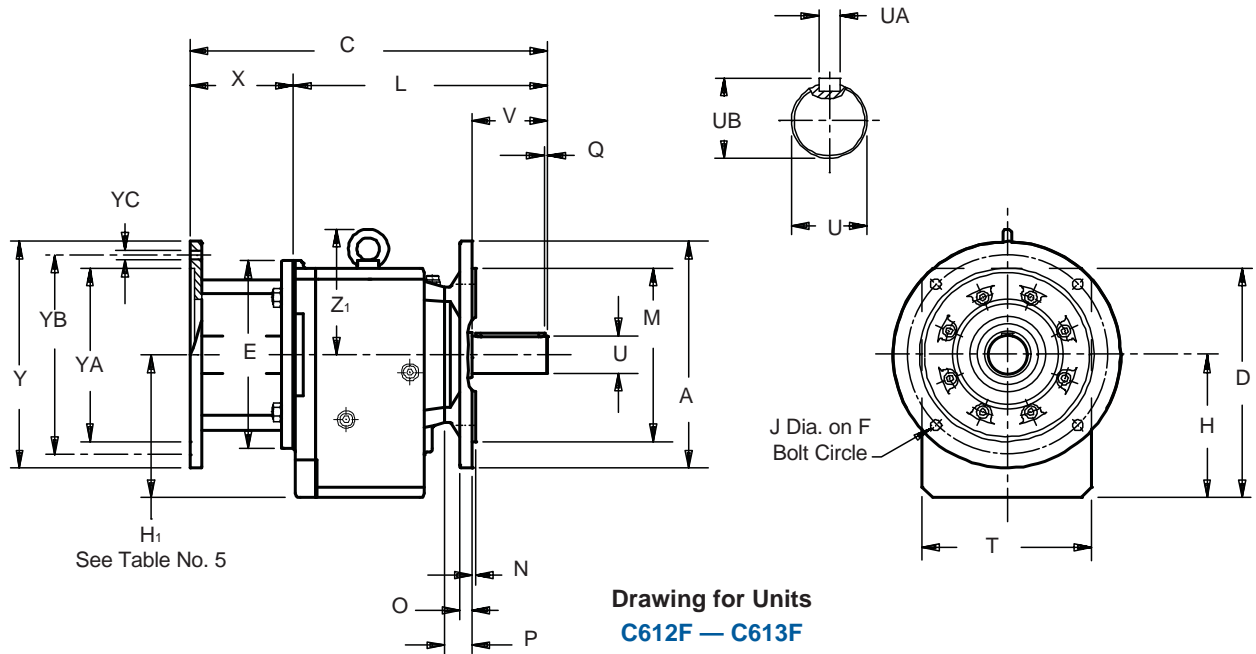
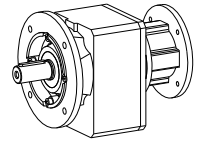

**Table No. 4 Beverage Duty "C" Series – Dimensions (Inches) – "F" Housing Style**

Base Module	MR140/050F		MR160/140F <sup>2)</sup>		MR200/180F		MR250/210F <sup>3)</sup>		MR300/250F <sup>4)</sup>		Approx. Wt. (lbs.)
	C	L	C	L	C	L	C	L	C	L	
<b>C002</b>	9.37	6.06	10.08	6.22	—	—	—	—	—	—	18
<b>C102</b>	10.67	7.36	11.38	7.52	12.40	7.60	—	—	—	—	34
<b>C103</b>	12.13	8.82	—	—	—	—	—	—	—	—	38
<b>C202</b>	11.77	8.46	12.48	8.62	13.50	8.70	—	—	—	—	45
<b>C203</b>	13.23	9.92	14.17	10.31	—	—	—	—	—	—	49
<b>C302</b>	—	—	13.23	9.37	14.25	9.45	14.88	9.57	—	—	56
<b>C303</b> <sup>1)</sup>	13.98	10.67	14.92	11.06	—	—	—	—	—	—	71
<b>C402</b>	—	—	15.12	11.26	16.14	11.34	16.77	11.46	—	—	78
<b>C403</b>	—	—	16.81	12.95	—	—	—	—	—	—	95
<b>C502</b>	—	—	15.95	12.09	16.97	12.17	17.59	12.28	19.33	12.83	111
<b>C503</b>	—	—	17.64	13.78	—	—	—	—	—	—	115
<b>C612</b> <sup>1)</sup>	—	—	—	—	17.91	13.11	18.54	13.23	20.24	13.74	159
<b>C613</b> <sup>1)</sup>	—	—	18.62	14.76	20.35	15.55	—	—	—	—	

<sup>1)</sup> See Table No. 5

<sup>2)</sup> Also available as **MR160/050F** for a NEMA 56C frame motor.

<sup>3)</sup> Also available as **MR250/180F** for a NEMA 182/184TC frame motor.

<sup>4)</sup> Also available as **MR300/180F** for a NEMA 182/184TC, **MR300/210F** for a NEMA 213/215TC, and **MR300/280F** for a NEMA 284/286TC frame motor.

All weights are approximate.

**Table No. 5 "C" Series – Input Dimension (Inches)**

Base Module	MR160/140F <sup>2)</sup>	MR200/180F	MR250/210F	MR300/250F
	H <sub>1</sub>	H <sub>1</sub>	H <sub>1</sub>	H <sub>1</sub>
<b>C303</b>	3.54	—	—	—
<b>C612</b>	—	7.44	7.44	7.44
<b>C613</b>	—	—	7.44	—

**Table No. 6 Optional Flange—Dimensions (Inches)**

Base Module	Flange Size	A	F	J	M	N	O
<b>C0</b>	120	4.724	3.93	.28	3.150	+0.01/-0.004	.12 .39
	140	5.512	4.53	.35	3.740	+0.01/-0.004	.12 .39
<b>C1</b>	140	5.512	4.53	.35	3.740	+0.01/-0.004	.14 .32
	160	6.300	5.12	.35	4.331	+0.01/-0.004	.14 .39
<b>C2</b>	160	6.300	5.12	.35	4.331	+0.01/-0.004	.14 .39
	250	9.843	8.46	.55	7.087	+0.01/-0.004	.16 .47
<b>C3</b>	160	6.300	5.12	.35	4.331	+0.01/-0.004	.14 .39
	200	7.874	6.50	.43	5.118	+0.01/-0.004	.14 .47
<b>C4</b>	200	7.874	6.50	.43	5.118	+0.01/-0.004	.16 .55
	300	11.811	10.43	.55	9.055	+0.01/-0.001	.16 .55
<b>C5</b>	250	9.843	8.46	.55	7.087	+0.01/-0.004	.16 .55

Optional flange are not available for all sizes.

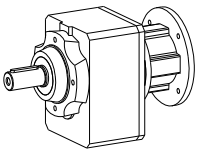

# Food Duty – "C" Series – MGS Reducer Tapped Holes – "G" Housing Dimensional Data

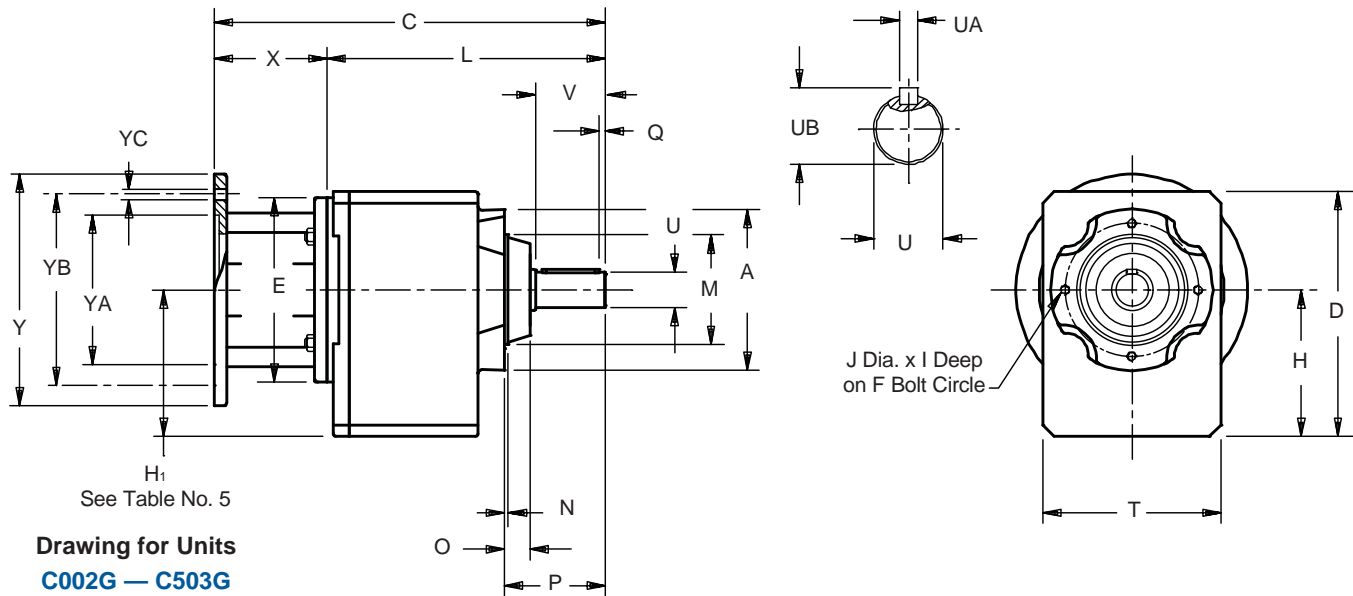

See Table No. 5

**Drawing for Units  
C002G – C503G**

**Table No. 1 Food Duty "C" Series – Tapped Holes Unit Dimensions (Inches) – "G" Housing Style**

Base Module	A	D	F	H	I	J	M	N	O	P	Q	T	V	Z <sub>1</sub>
<b>C002</b>	3.43	5.55	2.95	3.11	.39	M6	2.165	.12	.55	2.28	.16	3.82	1.57	—
<b>C102/C103</b>	4.72	6.89	3.94	3.94	.51	M6	3.150	.12	.67	2.80	.16	5.12	1.97	—
<b>C202/C203</b>	5.51	7.56	4.53	4.41	.51	M8	3.740	.12	.87	3.43	.16	5.59	2.36	—
<b>C302/C303</b>	5.51	8.35	4.53	5.00 <sup>1)</sup>	.51	M8	3.740	.12	.87	3.43	.16	6.06	2.36	—
<b>C402/C403</b>	6.30	9.55	5.12	5.61	.63	M10	4.331	.14	.87	4.25	.16	7.01	3.15	—
<b>C502/C503</b>	7.56	11.26	6.50 <sup>2)</sup>	6.54	.63	M10	5.118	.14	.91	4.29	.16	7.68	3.15	—
<b>C612/C613</b>	7.09	11.97	6.50	7.44 <sup>1)</sup>	.63	M10	5.512	.20	1.18	5.35	.20	8.86	3.94	6.57

<sup>1)</sup> See Table No. 5

<sup>2)</sup> C502/C503 has 8 holes instead of 4 as shown in the drawing.

**Table No. 2**

Base Module	Standard Shaft - inches		
	U	UA	UB
<b>C002</b>	.750	$\frac{3}{16} \times \frac{3}{16} \times \frac{17}{32}$	.83
<b>C102/C103</b>	1.000	$\frac{1}{4} \times \frac{1}{4} \times \frac{19}{16}$	1.11
<b>C202/C203</b>	1.250	$\frac{1}{4} \times \frac{1}{4} \times \frac{15}{16}$	1.36
<b>C302/C303</b>	1.250	$\frac{1}{4} \times \frac{1}{4} \times \frac{15}{16}$	1.36
<b>C402/C403</b>	1.625	$\frac{3}{8} \times \frac{3}{8} \times \frac{27}{8}$	1.79
<b>C502/C503</b>	1.625	$\frac{3}{8} \times \frac{3}{8} \times \frac{27}{8}$	1.79
<b>C612/C613</b>	2.125	$\frac{1}{2} \times \frac{1}{2} \times \frac{35}{32}$	2.35

**Table No. 3 Motor Adapter Dimensions (Inches)**

Motor Adapter	NEMA C-Flange	E	X	Y	YA	YB	YC	Wt. lbs.
<b>MR140/050F</b>	56C	5.51	3.31	6.50	4.500	5.87	.41	9
<b>MR160/050F</b>	56C	6.30	3.86	6.50	4.500	5.87	.41	16
<b>MR160/140F</b>	143/145TC	6.30	3.86	6.50	4.500	5.87	.41	16
<b>MR200/180F</b>	182/184TC	7.87	4.80	9.00	8.500	7.25	.55	23
<b>MR250/180F</b>	182/184TC	9.84	5.31	9.00	8.500	7.25	.55	36
<b>MR250/210F</b>	213/215TC	9.84	5.31	9.00	8.500	7.25	.55	36
<b>MR300/180F</b>	182/184TC	11.81	6.50	9.00	8.500	7.25	.57	75
<b>MR300/210F</b>	213/215TC	11.81	6.50	9.00	8.500	7.25	.57	75
<b>MR300/250F</b>	254/256TC	11.81	6.50	9.00	8.500	7.25	.57	75
<b>MR300/280F</b>	284/286TC	11.81	6.50	11.13	10.500	9.00	.57	75





# Food Duty – "C" Series – MGS Reducer Tapped Holes – "G" Housing Dimensional Data

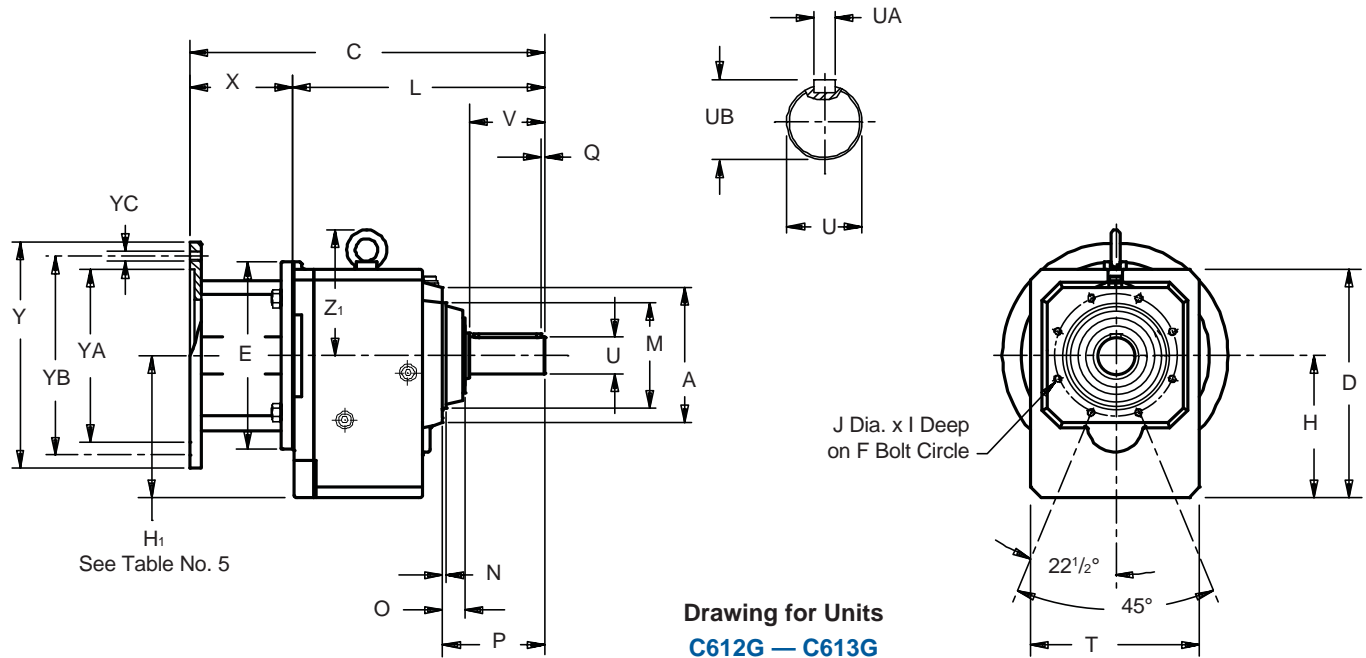
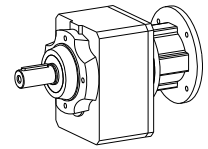

**Table No. 4 Food Duty "C" Series – "G" Housing Style – Dimensions (Inches)**

Base Module	MR140/050F		MR160/140F <sup>3)</sup>		MR200/180F		MR250/210F <sup>4)</sup>		MR300/250F <sup>5)</sup>		Approx. Wt.(lbs)
	C	L	C	L	C	L	C	L	C	L	
<b>C002</b>	9.37	6.06	10.08	6.22	—	—	—	—	—	—	18
<b>C102</b>	10.67	7.36	11.38	7.52	12.40	7.60	—	—	—	—	29
<b>C103</b>	12.13	8.82	—	—	—	—	—	—	—	—	34
<b>C202</b>	11.77	8.46	12.48	8.62	13.50	8.70	—	—	—	—	38
<b>C203</b>	13.23	9.92	14.17	10.31	—	—	—	—	—	—	45
<b>C302</b>	—	—	13.23	9.37	14.25	9.45	14.88	9.57	—	—	49
<b>C303</b> <sup>1)</sup>	13.98	10.67	14.92	11.06	—	—	—	—	—	—	56
<b>C402</b>	—	—	15.12	11.26	16.14	11.34	16.77	11.46	—	—	71
<b>C403</b>	—	—	16.81	12.95	—	—	—	—	—	—	78
<b>C502</b>	—	—	15.95	12.09	16.97	12.17	17.59	12.28	19.33	12.83	95
<b>C503</b>	—	—	17.64	13.78	—	—	—	—	—	—	111
<b>C612</b> <sup>1)</sup>	—	—	—	—	17.91	13.11	18.54	13.23	20.24	13.74	115
<b>C613</b> <sup>1)</sup>	—	—	18.62	14.76	20.35	15.55	—	—	—	—	159

<sup>1)</sup> See Table No. 5

<sup>3)</sup> Also available as **MR160/050F** for a NEMA 56C frame motor.

<sup>4)</sup> Also available as **MR250/180F** for a NEMA 182/184TC frame motor.

<sup>5)</sup> Also available as **MR300/180F** for a NEMA 182/184TC, **MR300/210F** for a NEMA 213/215TC, and **MR300/280F** for a NEMA 284/286TC frame motor.

All weights are approximate.

**Table No. 5 "C" Series – Input Dimension (Inches)**

Base	MR160/140F <sup>3)</sup>	MR200/180F	MR250/210F	MR300/250F
Module	H <sub>1</sub>	H <sub>1</sub>	H <sub>1</sub>	H <sub>1</sub>
<b>C303</b>	3.54	—	—	—
<b>C612</b>	—	7.44	7.44	7.44
<b>C613</b>	—	—	7.44	—

**Part No. Example**

Food Duty  
Tapped Holes Housing with Motor Adapter  
**C302G0620 MR160/140F**

# Beverage Duty – "K" Series – MGS Reducers Helical/Bevel with Double Bushing



## Reducer Configurations

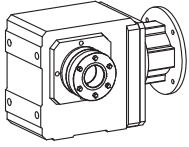

Style WG  
Double Bushing

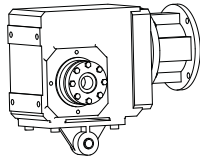

Style WGD  
Double Bushing  
with Torque Arm Bracket

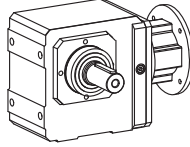

Style VG  
Output Shaft

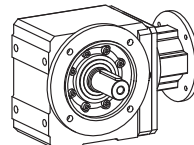

Style VF  
Output Shaft  
with Output Flange

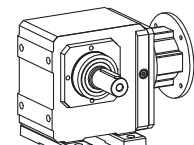

Style VN  
Output Shaft  
with Mounting Feet

## Mounting Positions – Standard 3 Year Warranty

One Standard Unit for ALL Horizontal Mounting Positions Without Changing the Oil Level

Standard Oil: Mobile XP600

Optional Oil: Food Grade Oil (Exxon Unisolv Special Mist 220)

Synthetic Oil (Mobil SHC630)

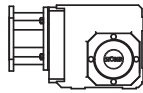

EL1

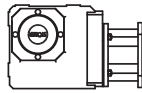

EL2

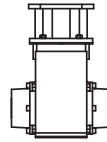

EL5

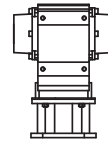

EL6

Possible – but not recommended

## Mounting Positions – Long Life 5 Year Warranty

Mounting Position MUST BE SPECIFIED

Standard Oil: Synthetic Oil (Mobil SHC630)

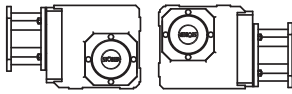

E12

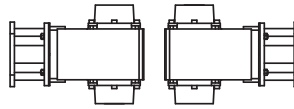

E34

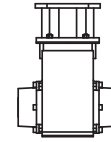

E5

## Part No. Explanation with OPTIONS

**K 6 1 3 W G 0580 MR160 / 140 B LL E12**

Mounting Position (Must be specified on LL.)

Long Life (Option)

B – Beverage Duty Coating

050 (56C), 140 (143/145TC), 180 (182/184TC), 210 (213/215TC),  
250 (254/256TC), 280 (284/286TC)

Motor Adapter Size: MR140, MR160, MR200, MR300

Nominal Ratio: (0580 = 57.5:1)

HOUSING STYLE: "F" Housing Style – Flange Mounting – **SPECIFY IN A NOTE:** Flange on Side 3 or Side 4

"G" Housing Style – Tapped Holes

"GD" G Housing with Torque Arm Bracket – **SPECIFY IN A NOTE:** Bracket on Side 1 or Side 5

"N" Housing Style – Foot Mount – **SPECIFY IN A NOTE:** Feet on Side 1 or Side 5

OUTPUT STYLE: "V" Single Side Solid Output – **SPECIFY IN A NOTE:** Shaft on Side 3 or Side 4

"W" Wobble Free Bushing

No. of Stages (3 = 3 Stage, determined by ratio)

Design Generation

Unit Size No.

Right Angle Helical/Bevel

## WFB 6–107

Output Bore in inches – 107 = 17/16

Base Module Size example: K613/K614)

Wobble Free Double Side

THE FOLLOWING OPTIONS ARE AVAILABLE FOR ANY UNIT:

Paint – White ..... Clear Coat

Oil – Food Grade ..... Synthetic



# Beverage Duty – "K" Series – MGS Reducers Helical/Bevel with Double Bushing

The standard "K" Series Helical/Bevel MGS Beverage Duty unit is supplied with a patented double sided wobble free bushing system. This unique design allows the unit to be mounted on the shaft from either side of the reducer. Featuring a distinct support side and a clamp side, the dual tapered cones will overcome a wide range of tolerances normally found with standard shaft materials. The clamp side is determined by the customer but is usually the outside bushing.

Each case size can be provided with a variety of bushing bore sizes. The unit is selected based on horsepower or torque rating, output speed or ratio, and the shaft size of the driven equipment. The bushing is not installed into the unit at the factory, but with easy to follow assemble instructions, the unit and bushing can be mounted on the machinery quickly – without any special tools. The bore size in the unit can be changed any time during the life of the unit simply by changing the bushing kit.

This unit has several features that make it virtually maintenance free in a **wet** or **dry** environment.

- Lubricated for Life
- Maintenance Free
- Totally Enclosed – no breather to allow contaminants in
- 3 Year Warranty – your guarantee of our confidence in the MGS (Modular Gear System) line of reducers
- 97% Efficiency – for high quality and reliability plus cost savings in energy and maintenance

Standard Coating – 1, Primer  
2, Industrial 316 Stainless Steel Epoxy

Optional Coating – Ultra Clear Industrial Epoxy  
– White Epoxy

NEMA C-face Input

- O-ring between the motor and reducer
- Easy mount maintenance free coupling

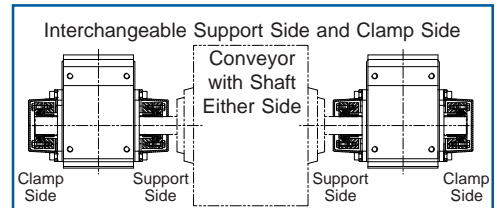

High efficiency spiral bevel gearing provides quiet operation and excellent torque carrying capacity

Nylon bolts on Side 1 (bottom) and Side 5 (shown) for protection during assembly

Stainless Steel Nameplate

High quality helical gearing is case hardened to 58-62 Rockwell C. Precision finished for low noise and long service life. Standard backlash is  $\leq 12$  arc minutes

Outside Closed Cover Cap – with O-ring to protect seals from high pressure washing

Patented<sup>(1)</sup> Stainless Steel Double Sided Bushing Mounted into Stainless Steel Output Quill – easily mounts onto standard cold finished, ground, or stainless shafting.

Both Sides of Output Double Sealed – with a dual lip outer seal and a single lip inner seal

ALL Stainless Steel Hardware

Inside Split Cover Cap – enables easy assembly onto the shaft

<sup>(1)</sup> U.S. Patent Number 5,496,127

**See Pages 116-139 for Selection Data.**

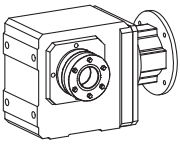

# Beverage Duty – "K" Series – MGS Reducer Tapped Hole – "G" Housing Double Bushing – Dimensional Data

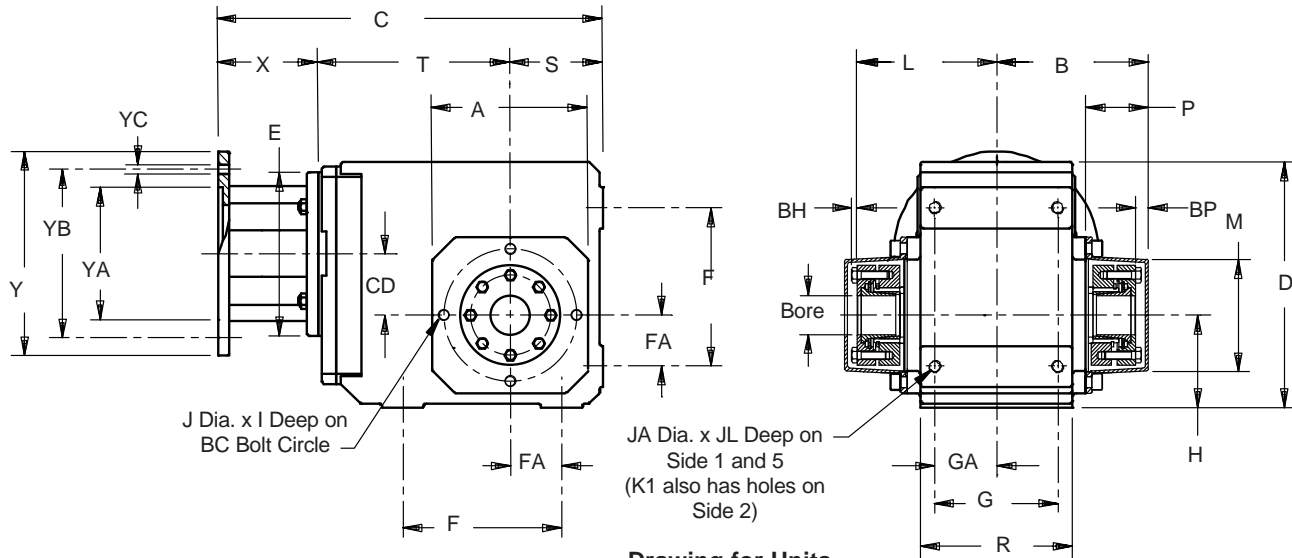

**Drawing for Units  
K102WG – K403WG**

**Table No. 1 Beverage Duty – "K" Series – Double Side Bushing – Unit Dimensions (Inches)**

Base Module	Max. Bore	A	B	D	F	G	H	I	J	L	M	P	R	S	Z <sub>1</sub>	BC	BP	BH	FA	GA	JA	JL
<b>K102</b>	1.000	4.13	3.90	6.30	3.54	2.76	2.36	.51	M8	3.66	3.07	1.97	3.54	2.36	—	3.54	.24	.16	1.18	1.38	M8	.51
<b>K202/203</b>	1.187	4.57	4.68	7.48	4.53	3.54	2.56	.51	M8	4.26	3.46	2.05	4.53	2.56	—	3.94	.39	.16	1.38	1.77	M10	.63
<b>K302/303</b>	1.500	5.20	4.98	8.39	5.12	4.13	2.95	.51	M8	4.54	3.78	2.09	5.12	2.95	—	4.53	.43	.16	1.57	2.07	M10	.63
<b>K402/403</b>	1.500	5.98	5.80	9.45	6.10	4.72	3.54	.63	M10	5.33	4.33	2.40	5.83	3.54	—	5.12	.47	.20	1.97	2.36	M12	.75
<b>K513/514</b>	2.000	5.71	6.05	10.24	5.51	4.92	6.30	.63	M10	5.61	4.54	2.40	6.30	3.94	5.98	5.12	.43	.20	1.57	2.46	M16	1.02
<b>K613/614</b>	2.187	7.09	6.61	12.20	6.30	5.12	7.48	.63	M10	6.10	5.00	2.68	6.61	4.72	6.77	6.50	.51	.24	1.97	2.56	M16	1.02
<b>K713/714</b>	2.375	7.68	7.68	13.46	7.09	5.71	8.35	.75	M12	7.29	5.75	2.91	7.48	4.92	7.52	7.28	.39	.24	2.17	2.85	M20	1.22
<b>K813/814</b>	2.750	8.90	9.34	16.14	9.45	7.28	10.43	.75	M12	8.70	6.95	3.43	9.25	5.71	8.11	8.46	.64	.31	2.95	3.64	M24	1.50

**Table No. 2 Motor Adapter Dimensions (Inches)**

Motor Adapter	NEMA C-Flange	E	X	Y	YA	YB	YC	Wt. lbs.
<b>MR140/050B</b>	56C	5.51	3.31	6.50	4.500	5.87	.41	9
<b>MR160/050B</b>	56C	6.30	3.86	6.50	4.500	5.87	.41	16
<b>MR160/140B</b>	143/145TC	6.30	3.86	6.50	4.500	5.87	.41	16
<b>MR200/180B</b>	182/184TC	7.87	4.80	9.00	8.500	7.25	.55	23
<b>MR250/180B</b>	182/184TC	9.84	5.31	9.00	8.500	7.25	.55	36
<b>MR250/210B</b>	213/215TC	9.84	5.31	9.00	8.500	7.25	.55	36
<b>MR300/180B</b>	182/184TC	11.81	6.50	9.00	8.500	7.25	.57	75
<b>MR300/210B</b>	213/215TC	11.81	6.50	9.00	8.500	7.25	.57	75
<b>MR300/250B</b>	254/256TC	11.81	6.50	9.00	8.500	7.25	.57	75
<b>MR300/280B</b>	284/286TC	11.81	6.50	11.13	10.500	9.00	.57	75

**Part No. Example**  
Beverage Duty Unit  
143TC Frame Motor Adapter  
and 17/16 Bushing Bore  
**K303WG0650 MR160/140B  
WFB3-107**

**Table No. 3 "WFB" – Double Side Bushings – Metric**

Unit	Stock Bores Sizes – mm			
	25	30	35	40
<b>K1</b>	<b>WFB1-25</b>	—	—	—
<b>K2</b>	—	<b>WFB2-30</b>	—	—
<b>K3</b>	—	<b>WFB3-30</b>	<b>WFB3-35</b>	—
<b>K4</b>	—	—	—	<b>WFB4-40</b>
<b>K5</b>	—	—	—	<b>WFB5-40</b>
<b>K6</b>	—	—	—	<b>WFB6-40</b>

**Table No. 4 "WFB" Double Side Bushings – Inches**

Unit	Stock Bores Sizes					
	1	1 <sup>3</sup> / <sub>16</sub>	1 <sup>1</sup> / <sub>4</sub>	1 <sup>3</sup> / <sub>8</sub>	1 <sup>7</sup> / <sub>16</sub>	1 <sup>1</sup> / <sub>2</sub>
<b>K1</b>	<b>WFB1-100</b>	—	—	—	—	—
<b>K2</b>	<b>WFB2-100</b>	<b>WFB2-103</b>	—	—	—	—
<b>K3</b>	<b>WFB3-100</b>	<b>WFB3-103</b>	<b>WFB3-104</b>	<b>WFB3-106</b>	<b>WFB3-107</b>	<b>WFB3-108</b>
<b>K4</b>	<b>WFB4-100</b>	<b>WFB4-103</b>	<b>WFB4-104</b>	<b>WFB4-106</b>	<b>WFB4-107</b>	<b>WFB4-108</b>



# Beverage Duty – "K" Series – MGS Reducer Tapped Hole – "G" Housing Double Bushing – Dimensional Data

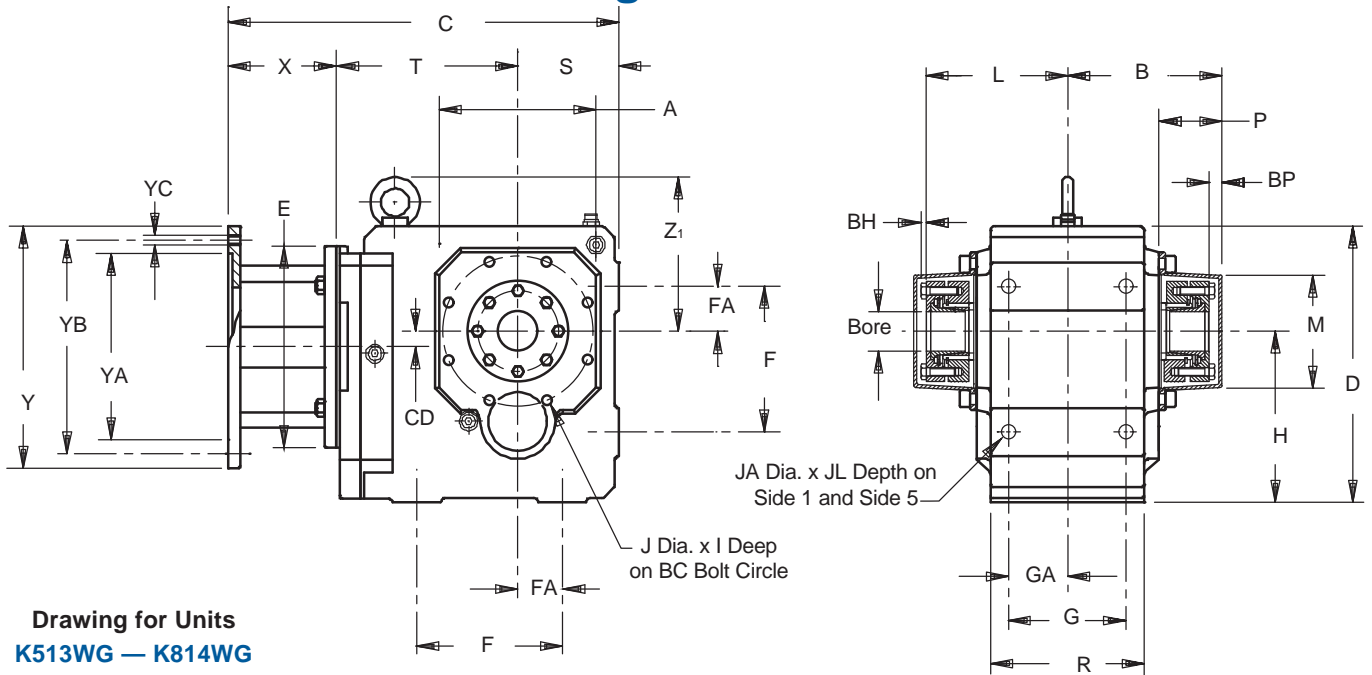
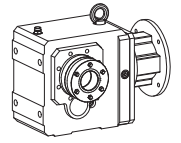

Drawing for Units  
K513WG — K814WG

Table No. 5 Beverage Duty – "K" Series – Double Wobble Free – Unit Dimensions (Inches)

Base	MR140/050B			MR160/140B <sup>1)</sup>			MR200/180B			MR250/210B <sup>2)</sup>			MR300/250B <sup>3)</sup>			Wt.
Module	CD	C	T	CD	C	T	CD	C	T	CD	C	T	CD	C	T	lbs.
K102	1.42	10.55	4.88	1.42	11.26	5.04	—	—	—	—	—	—	—	—	—	31
K202	1.81	11.50	5.63	1.81	12.21	5.79	1.81	13.23	5.87	—	—	—	—	—	—	40
K203	1.81	12.96	7.09	—	—	—	—	—	—	—	—	—	—	—	—	53
K302	2.07	12.68	6.42	2.07	13.38	6.57	2.07	14.40	6.65	—	—	—	—	—	—	67
K303	2.07	14.13	7.87	.63	15.08	8.27	—	—	—	—	—	—	—	—	—	73
K402	—	—	—	2.36	14.76	7.36	2.36	15.74	7.44	2.36	16.41	7.56	—	—	—	93
K403	2.36	15.51	8.66	.91	16.46	9.06	—	—	—	—	—	—	—	—	—	100
K513	—	—	—	.59	14.57	6.77	.59	15.59	6.85	.59	16.22	6.97	—	—	—	106
K514	—	—	—	.59	16.26	8.46	—	—	—	—	—	—	—	—	—	109
K613	—	—	—	.71	16.10	7.52	.71	17.12	7.60	.71	17.75	7.72	.71	19.49	8.27	170
K614	—	—	—	.71	17.79	9.21	—	—	—	—	—	—	—	—	—	177
K713	—	—	—	—	—	—	.79	18.42	8.70	.79	19.05	8.82	.79	20.75	9.33	221
K714	—	—	—	.79	19.13	10.35	.79	20.86	11.14	—	—	—	—	—	—	234
K813	—	—	—	—	—	—	.94	20.23	9.72	.94	20.82	9.80	.94	22.52	10.31	309
K814	—	—	—	—	—	—	.94	22.64	12.13	—	—	—	—	—	—	331

<sup>1)</sup> Also available as MR160/050B for a NEMA 56C frame motor.

<sup>2)</sup> Also available as MR250/180B for a NEMA 182/184TC frame motor.

<sup>3)</sup> Also available as MR300/180B for NEMA 182/184TC, MR300/210B for NEMA 213/215TC, and MR300/280B for NEMA 284/286TC frame motor.

All weights are approximate.

**NOTE:** A double side bushing kit includes 2 each of a pressure ring and clamp ring, flanged and tapered cone, and all hardware to mount the kit into the reducer. The WFB1 does not use a tapered cone. All double bushing kits include covers. The bushing will accept a shaft with a tolerance of +.000/-.005.

Table No. 6 "WFB" Double Side Bushings – Inches

Unit	Stock Bores Sizes – Inches											
	1 <sup>7</sup> / <sub>16</sub>	1 <sup>1</sup> / <sub>2</sub>	1 <sup>5</sup> / <sub>8</sub>	1 <sup>11</sup> / <sub>16</sub>	1 <sup>3</sup> / <sub>4</sub>	1 <sup>7</sup> / <sub>8</sub>	1 <sup>15</sup> / <sub>16</sub>	2	2 <sup>3</sup> / <sub>16</sub>	2 <sup>3</sup> / <sub>8</sub>	2 <sup>7</sup> / <sub>16</sub>	2 <sup>3</sup> / <sub>4</sub>
K5	WFB5-107	WFB5-108	WFB5-110	WFB5-111	WFB5-112	WFB5-114	WFB5-115	WFB5-200	—	—	—	—
K6	WFB6-107	WFB6-108	WFB6-110	WFB6-111	WFB6-112	—	WFB6-115	WFB6-200	WFB6-203	—	—	—
K7	—	—	—	—	—	—	WFB7-115	WFB7-200	WFB7-203	WFB7-206	—	—
K8	—	—	—	—	—	—	—	—	WFB8-203	WFB8-206	WFB8-207	WFB8-212





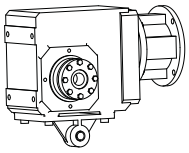

# Beverage Duty – "K" Series – MGS Reducer Torque Arm Bracket – "GD" Housing Double Bushing – Dimensional Data

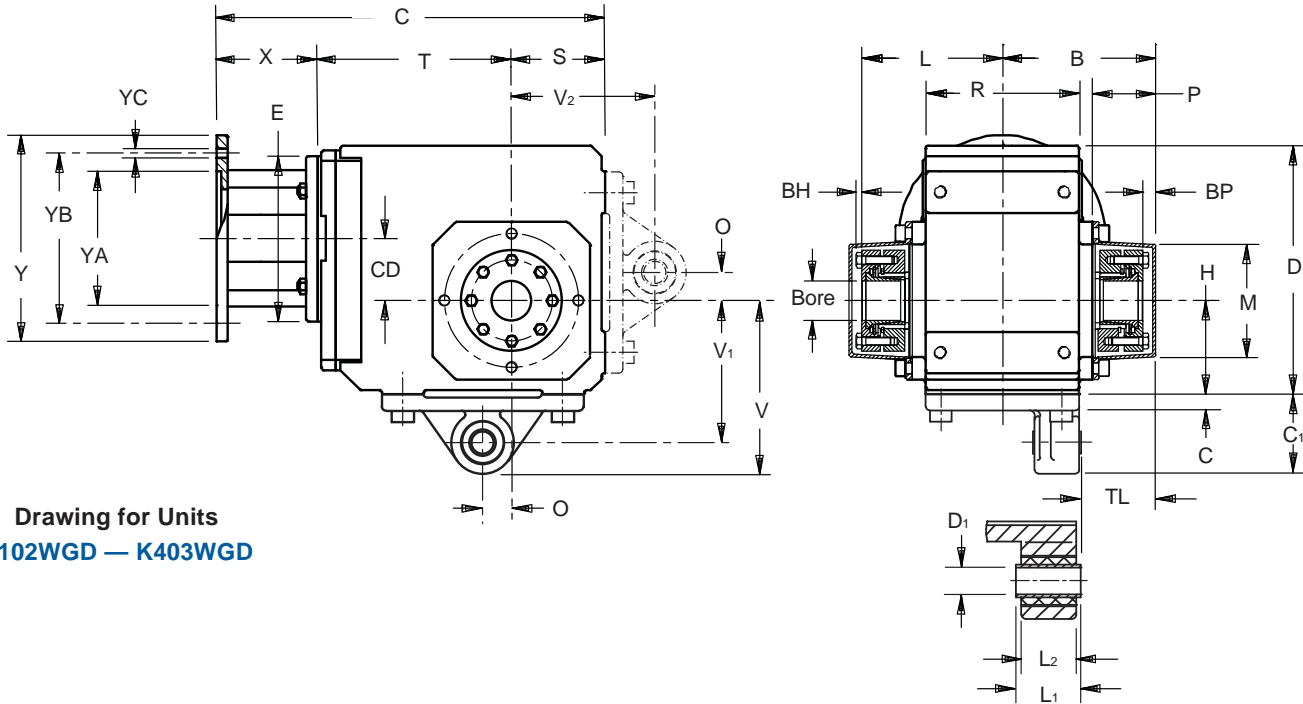

Drawing for Units  
K102WGD – K403WGD

Table No. 1 Beverage Duty – "K" Series – Double Wobble Free – Unit Dimensions (Inches)

Base Module	B	C	C <sub>1</sub>	D	D <sub>1</sub> H9	H	L	L <sub>1</sub>	L <sub>2</sub>	M	O	P	R	S	V	V <sub>1</sub>	V <sub>2</sub>	Z <sub>1</sub>	BP	BH	TL
<b>K102</b>	3.90	.39	2.03	6.30	.47 +0.017/-0.000	2.36	3.66	1.10	.94	3.07	.59	1.97	3.54	2.36	4.39	3.54	3.54	—	.24	.16	2.05
<b>K202/203</b>	4.68	.47	2.26	7.48	.63 +0.017/-0.000	2.56	4.26	1.50	1.26	3.46	.89	2.05	4.53	2.56	4.82	3.93	3.93	—	.39	.16	2.29
<b>K302/303</b>	4.98	.47	2.66	8.39	.63 +0.017/-0.000	2.95	4.54	1.50	1.26	3.78	.98	2.09	5.12	2.95	5.61	4.72	4.72	—	.43	.16	2.30
<b>K402/403</b>	5.80	.55	3.46	9.45	.79 +0.020/-0.000	3.54	5.33	1.81	1.57	4.33	1.08	2.40	5.83	3.54	7.00	5.91	5.91	—	.47	.20	2.77
<b>K513/514</b>	6.05	.59	4.68	10.24	.79 +0.020/-0.000	6.30	5.61	1.81	1.57	4.54	1.18	2.40	6.30	3.94	10.98	9.84	7.48	5.98	.43	.20	2.78
<b>K613/614</b>	6.61	.59	3.50	12.20	.79 +0.020/-0.000	7.48	6.10	1.81	1.57	5.00	1.18	2.68	6.61	4.72	10.98	9.84	7.09	6.77	.51	.24	3.16
<b>K713/714</b>	7.68	.67	4.80	13.46	.79 +0.020/-0.000	8.35	7.29	2.76	2.52	5.75	1.38	2.91	7.48	4.92	13.15	11.81	8.39	7.52	.39	.24	3.82
<b>K813/814</b>	9.34	.67	4.77	16.14	.94 +0.020/-0.000	10.43	8.70	4.53	4.02	6.95	1.77	3.43	9.25	5.71	15.20	13.78	9.06	8.11	.64	.31	4.45

Table No. 2 Motor Adapter Dimensions (Inches)

Motor Adapter	NEMA C-Flange	E	X	Y	YA	YB	YC	Wt. lbs.
<b>MR140/050B</b>	56C	5.51	3.31	6.50	4.500	5.87	.41	9
<b>MR160/050B</b>	56C	6.30	3.86	6.50	4.500	5.87	.41	16
<b>MR160/140B</b>	143/145TC	6.30	3.86	6.50	4.500	5.87	.41	16
<b>MR200/180B</b>	182/184TC	7.87	4.80	9.00	8.500	7.25	.55	23
<b>MR250/180B</b>	182/184TC	9.84	5.31	9.00	8.500	7.25	.55	36
<b>MR250/210B</b>	213/215TC	9.84	5.31	9.00	8.500	7.25	.55	36
<b>MR300/180B</b>	182/184TC	11.81	6.50	9.00	8.500	7.25	.57	75
<b>MR300/210B</b>	213/215TC	11.81	6.50	9.00	8.500	7.25	.57	75
<b>MR300/250B</b>	254/256TC	11.81	6.50	9.00	8.500	7.25	.57	75
<b>MR300/280B</b>	284/286TC	11.81	6.50	11.13	10.500	9.00	.57	75

**Part No. Example**  
Beverage Duty Unit  
with Torque Arm Bracket  
143TC Frame Motor Adapter  
and 17/16 Bushing Bore  
**K303WGD0650 MR160/140B**  
**WFB3-107**

Table No. 3 "WFB" – Double Side Bushings – Metric

Unit	Stock Bores Sizes – mm			
	25	30	35	40
<b>K1</b>	<b>WFB1-25</b>	—	—	—
<b>K2</b>	—	<b>WFB2-30</b>	—	—
<b>K3</b>	—	<b>WFB3-30</b>	<b>WFB3-35</b>	—
<b>K4</b>	—	—	—	<b>WFB4-40</b>
<b>K5</b>	—	—	—	<b>WFB5-40</b>
<b>K6</b>	—	—	—	<b>WFB6-40</b>

Table No. 4 "WFB" Double Side Bushings – Inches

Unit	Stock Bores Sizes					
	1	1 <sup>3</sup> / <sub>16</sub>	1 <sup>1</sup> / <sub>4</sub>	1 <sup>3</sup> / <sub>8</sub>	1 <sup>7</sup> / <sub>16</sub>	1 <sup>1</sup> / <sub>2</sub>
<b>K1</b>	<b>WFB1-100</b>	—	—	—	—	—
<b>K2</b>	<b>WFB2-100</b>	<b>WFB2-103</b>	—	—	—	—
<b>K3</b>	<b>WFB3-100</b>	<b>WFB3-103</b>	<b>WFB3-104</b>	<b>WFB3-106</b>	<b>WFB3-107</b>	<b>WFB3-108</b>
<b>K4</b>	<b>WFB4-100</b>	<b>WFB4-103</b>	<b>WFB4-104</b>	<b>WFB4-106</b>	<b>WFB4-107</b>	<b>WFB4-108</b>



# Beverage Duty – "K" Series – MGS Reducer Torque Arm Bracket – "GD" Housing Double Bushing – Dimensional Data

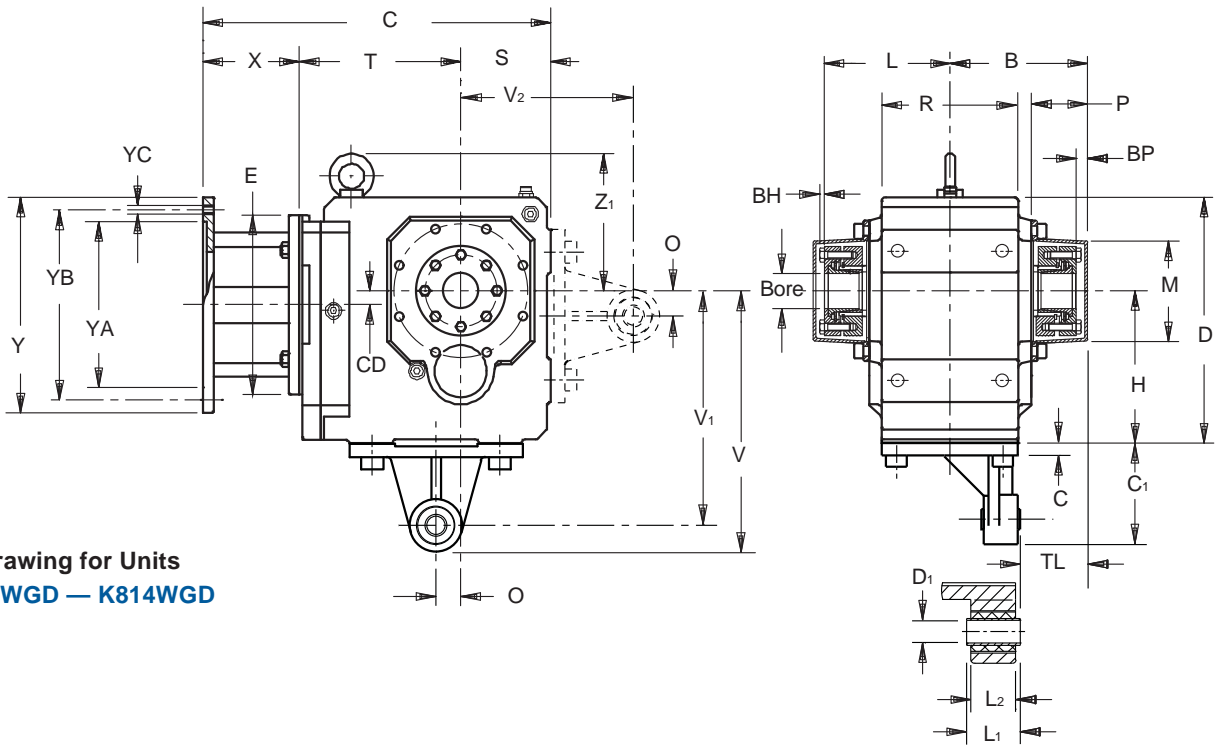
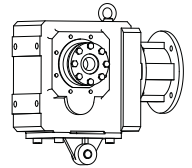

Drawing for Units  
K513WGD – K814WGD

Table No. 5 Beverage Duty – "K" Series – Unit Dimensions (Inches)

Base Module	MR140/050B			MR160/140B <sup>1)</sup>			MR200/180B			MR250/210B <sup>2)</sup>			MR300/250B <sup>3)</sup>			Wt. lbs.
	CD	C	T	CD	C	T	CD	C	T	CD	C	T	CD	C	T	
K102	1.42	10.55	4.88	1.42	11.26	5.04	—	—	—	—	—	—	—	—	—	31
K202	1.81	11.50	5.63	1.81	12.21	5.79	1.81	13.23	5.87	—	—	—	—	—	—	40
K203	1.81	12.96	7.09	—	—	—	—	—	—	—	—	—	—	—	—	53
K302	2.07	12.68	6.42	2.07	13.38	6.57	2.07	14.40	6.65	—	—	—	—	—	—	67
K303	2.07	14.13	7.87	.63	15.08	8.27	—	—	—	—	—	—	—	—	—	73
K402	—	—	—	2.36	14.76	7.36	2.36	15.74	7.44	2.36	16.41	7.56	—	—	—	93
K403	2.36	15.51	8.66	.91	16.46	9.06	—	—	—	—	—	—	—	—	—	100
K513	—	—	—	.59	14.57	6.77	.59	15.59	6.85	.59	16.22	6.97	—	—	—	106
K514	—	—	—	.59	16.26	8.46	—	—	—	—	—	—	—	—	—	109
K613	—	—	—	.71	16.10	7.52	.71	17.12	7.60	.71	17.75	7.72	.71	19.49	8.27	170
K614	—	—	—	.71	17.79	9.21	—	—	—	—	—	—	—	—	—	177
K713	—	—	—	—	—	—	.79	18.42	8.70	.79	19.05	8.82	.79	20.75	9.33	221
K714	—	—	—	.79	19.13	10.35	.79	20.86	11.14	—	—	—	—	—	—	234
K813	—	—	—	—	—	—	.94	20.23	9.72	.94	20.82	9.80	.94	22.52	10.31	309
K814	—	—	—	—	—	—	.94	22.64	12.13	—	—	—	—	—	—	331

<sup>1)</sup> Also available as MR160/050B for a NEMA 56C frame motor.

<sup>2)</sup> Also available as MR250/180B for a NEMA 182/184TC frame motor.

<sup>3)</sup> Also available as MR300/180B for NEMA 182/184TC, MR300/210B for NEMA 213/215TC, and MR300/280B for NEMA 284/286TC frame motor.

All weights are approximate.

**NOTE:** A double side bushing kit includes 2 each of a pressure ring and clamp ring, flanged and tapered cone, and all hardware to mount the kit into the reducer. The WFB1 does not use a tapered cone. All double bushing kits include covers. The bushing will accept a shaft with a tolerance of +.000/-.005.

Table No. 6 "WFB" Double Side Bushings – Inches

Unit	Stock Bores Sizes – Inches											
	1 <sup>7</sup> / <sub>16</sub>	1 <sup>1</sup> / <sub>2</sub>	1 <sup>5</sup> / <sub>8</sub>	1 <sup>11</sup> / <sub>16</sub>	1 <sup>3</sup> / <sub>4</sub>	1 <sup>7</sup> / <sub>8</sub>	1 <sup>15</sup> / <sub>16</sub>	2	2 <sup>3</sup> / <sub>16</sub>	2 <sup>3</sup> / <sub>8</sub>	2 <sup>7</sup> / <sub>16</sub>	2 <sup>3</sup> / <sub>4</sub>
K5	WFB5-107	WFB5-108	WFB5-110	WFB5-111	WFB5-112	WFB5-114	WFB5-115	WFB5-200	—	—	—	—
K6	WFB6-107	WFB6-108	WFB6-110	WFB6-111	WFB6-112	—	WFB6-115	WFB6-200	WFB6-203	—	—	—
K7	—	—	—	—	—	—	WFB7-115	WFB7-200	WFB7-203	WFB7-206	—	—
K8	—	—	—	—	—	—	—	—	WFB8-203	WFB8-206	WFB8-207	WFB8-212

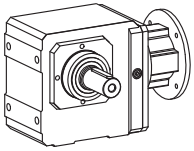

# Beverage Duty – "K" Series – MGS Reducer Tapped Holes – "G" Housing Shaft Output – Dimensional Data

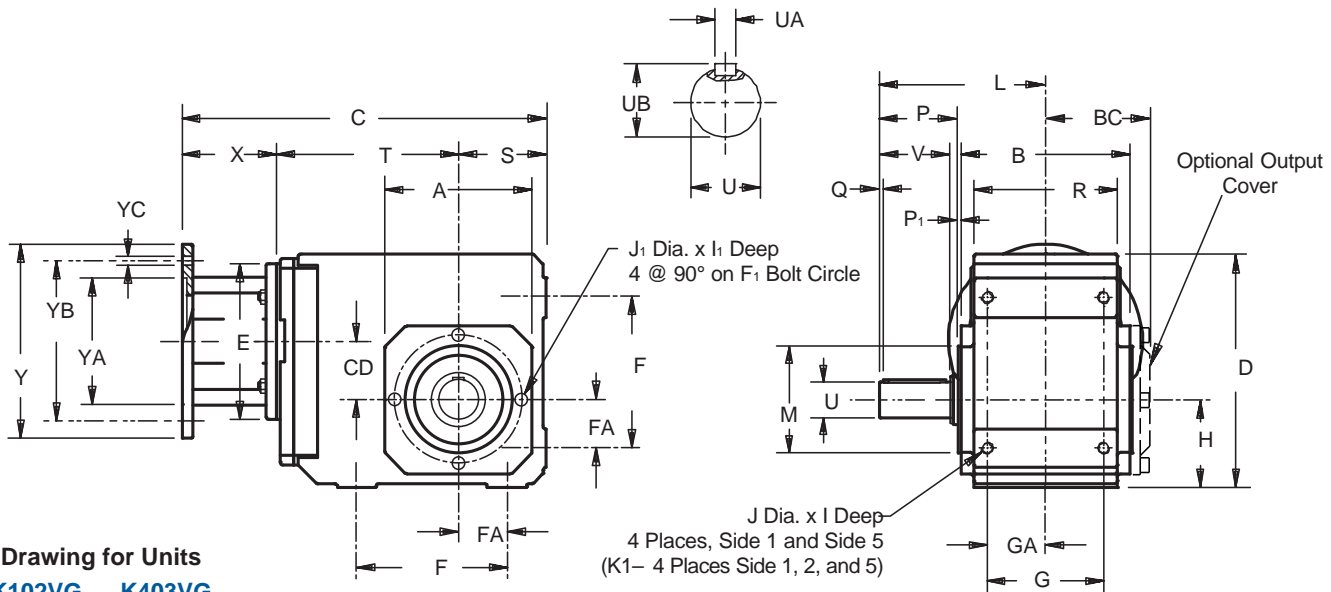

Drawing for Units  
K102VG — K403VG

Table No. 1 "K" Series – Unit Dimensions (Inches) – "G" Housing Style

Base Module	A	B	BC	D	F	F <sub>1</sub>	FA	G	GA	H	I	I <sub>1</sub>	J	J <sub>1</sub>	L
K102	4.13	4.17	2.64	6.30	3.54	3.54	1.18	2.76	1.38	2.36	.51	.51	M8	M8	4.53
K202/203	4.57	5.28	3.23	7.48	4.53	3.94	1.38	3.54	1.77	2.56	.63	.51	M10	M8	5.31
K302/303	5.20	5.75	3.46	8.39	5.12	4.53	1.57	4.13	2.07	2.95	.63	.51	M10	M8	5.59
K402/403	5.98	6.81	4.08	9.45	6.10	5.12	1.97	4.72	2.36	3.54	.75	.63	M12	M10	6.54
K513/514	5.71	7.28	4.31	10.24	5.51	5.12	1.57	4.92	2.46	6.30	1.02	.63	M16	M10	8.74
K613/614	7.09	7.87	4.61	12.20	6.30	6.50	1.97	5.12	2.56	7.48	1.02	.63	M16	M10	9.29
K713/714	7.68	8.90	5.08	13.46	7.09	7.28	2.17	5.71	2.85	8.35	1.22	.75	M20	M12	10.91
K813/814	8.90	11.10	6.26	16.14	9.45	8.46	2.95	7.28	3.64	10.43	1.50	.75	M24	M12	12.83

Table No. 2

Base Module	M	O	P	P <sub>1</sub>	R	Q	S	U	UA – Key	UB	V	Z <sub>1</sub>
K102	2.953	—	2.32	.12	3.54	.16	2.36	1.000	1/4 x 1/4 x 1 <sup>9</sup> / <sub>16</sub>	1.11	1.97	—
K202/203	3.228	—	2.56	.12	4.53	.16	2.56	1.250	1/4 x 1/4 x 1 <sup>15</sup> / <sub>16</sub>	1.36	2.36	—
K302/303	3.740	—	2.60	.12	5.12	.16	2.95	1.250	1/4 x 1/4 x 1 <sup>15</sup> / <sub>16</sub>	1.36	2.36	—
K402/403	4.331	—	3.39	.14	5.83	.16	3.54	1.375	5/16 x 5/16 x 2 <sup>5</sup> / <sub>16</sub>	1.51	2.76	—
K513/514	4.331	5.10	3.90	.14	6.30	.16	3.94	1.750	3/8 x 3/8 x 3 <sup>5</sup> / <sub>32</sub>	1.92	3.54	5.98
K613/614	5.512	5.35	4.31	.14	6.61	.16	4.72	1.750	3/8 x 3/8 x 3 <sup>5</sup> / <sub>32</sub>	1.92	3.94	6.77
K713/714	6.102	6.46	5.14	.14	7.48	.16	4.92	2.375	5/8 x 5/8 x 3 <sup>15</sup> / <sub>16</sub>	2.65	4.72	7.52
K813/814	7.283	7.28	5.94	.16	9.25	.20	5.71	2.875	3/4 x 3/4 x 4 <sup>5</sup> / <sub>16</sub>	3.21	5.51	8.11

Table No. 3 Motor Adapter Dimensions (Inches)

Motor Adapter	NEMA C-Flange	E	X	Y	YA	YB	YC	Wt. lbs.
MR140/050B	56C	5.51	3.31	6.50	4.500	5.87	.41	9
MR160/050B	56C	6.30	3.86	6.50	4.500	5.87	.41	16
MR160/140B	143/145TC	6.30	3.86	6.50	4.500	5.87	.41	16
MR200/180B	182/184TC	7.87	4.80	9.00	8.500	7.25	.55	23
MR250/180B	182/184TC	9.84	5.31	9.00	8.500	7.25	.55	36
MR250/210B	213/215TC	9.84	5.31	9.00	8.500	7.25	.55	36
MR300/180B	182/184TC	11.81	6.50	9.00	8.500	7.25	.57	75
MR300/210B	213/215TC	11.81	6.50	9.00	8.500	7.25	.57	75
MR300/250B	254/256TC	11.81	6.50	9.00	8.500	7.25	.57	75
MR300/280B	284/286TC	11.81	6.50	11.13	10.500	9.00	.57	75



# Beverage Duty – "K" Series – MGS Reducer Tapped Holes – "G" Housing Shaft Output – Dimensional Data

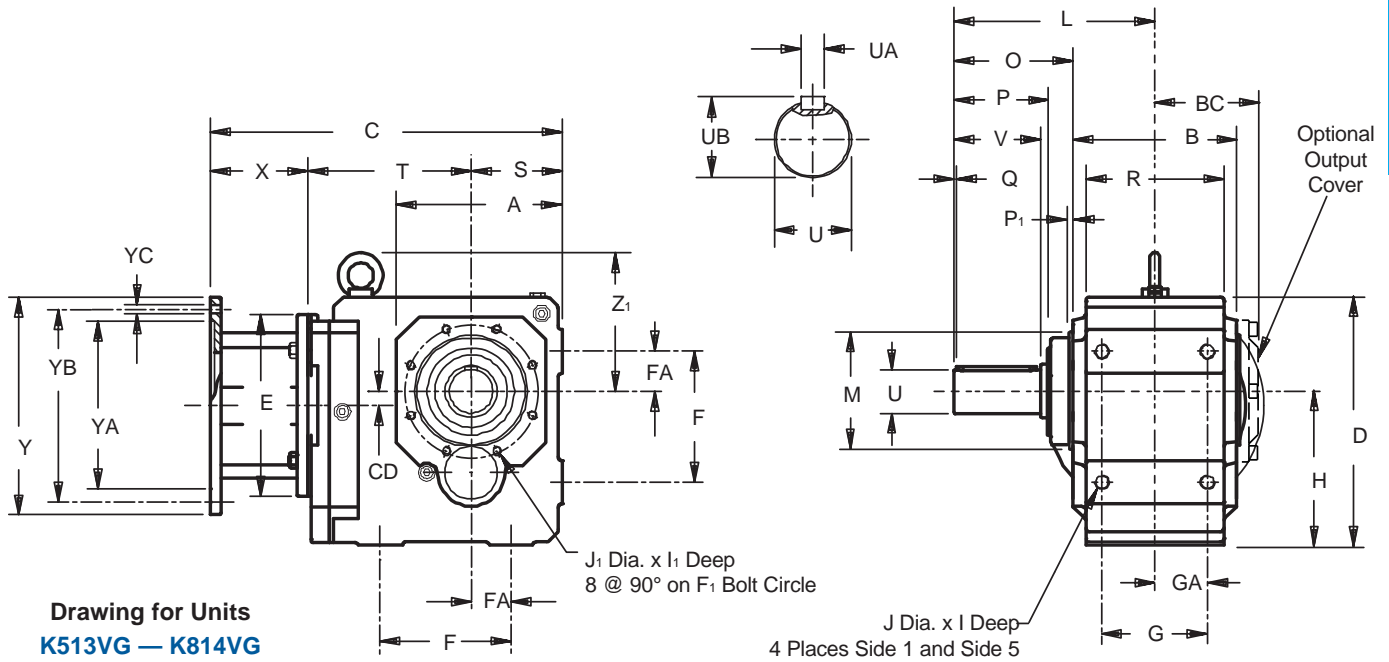
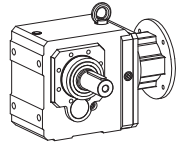

Drawing for Units  
K513VG – K814VG

Table No. 4 "K" Series – Unit Dimensions (Inches)

Base Module	MR140/050B			MR160/140B <sup>1)</sup>			MR200/180B			MR250/210B <sup>2)</sup>			MR300/250B <sup>3)</sup>			Wt. lbs.
	CD	C	T	CD	C	T	CD	C	T	CD	C	T	CD	C	T	
K102	1.42	10.55	4.88	1.42	11.26	5.04	—	—	—	—	—	—	—	—	—	31
K202	1.81	11.50	5.63	1.81	12.21	5.79	1.81	13.23	5.87	—	—	—	—	—	—	40
K203	1.81	12.96	7.09	—	—	—	—	—	—	—	—	—	—	—	—	53
K302	2.07	12.68	6.42	2.07	13.38	6.57	2.07	14.40	6.65	—	—	—	—	—	—	67
K303	2.07	14.13	7.87	.63	15.08	8.27	—	—	—	—	—	—	—	—	—	73
K402	—	—	—	2.36	14.76	7.36	2.36	15.74	7.44	2.36	16.41	7.56	—	—	—	93
K403	2.36	15.51	8.66	.91	16.46	9.06	—	—	—	—	—	—	—	—	—	100
K513	—	—	—	.59	14.57	6.77	.59	15.59	6.85	.59	16.22	6.97	—	—	—	106
K514	—	—	—	.59	16.26	8.46	—	—	—	—	—	—	—	—	—	109
K613	—	—	—	.71	16.10	7.52	.71	17.12	7.60	.71	17.75	7.72	.71	19.49	8.27	170
K614	—	—	—	.71	17.79	9.21	—	—	—	—	—	—	—	—	—	177
K713	—	—	—	—	—	—	.79	18.42	8.70	.79	19.05	8.82	.79	20.75	9.33	221
K714	—	—	—	.79	19.13	10.35	.79	20.86	11.14	—	—	—	—	—	—	234
K813	—	—	—	—	—	—	.94	20.23	9.72	.94	20.82	9.80	.94	22.52	10.31	309
K814	—	—	—	—	—	—	.94	22.64	12.13	—	—	—	—	—	—	331

<sup>1)</sup> Also available as MR160/050B for a NEMA 56C frame motor.

<sup>2)</sup> Also available as MR250/180B for a NEMA 182/184TC frame motor.

<sup>3)</sup> Also available as MR300/180B for a NEMA 182/184TC, MR300/210B for a NEMA 213/215TC, and MR300/280B for a NEMA 284/286TC frame motor. All weights are approximate.

### Part No. Example

Beverage Duty  
Tapped Hole Housing with Motor Adapter

**K303VG0650 MR160/140B**

**Specify: Shaft Side 3 or Side 4**

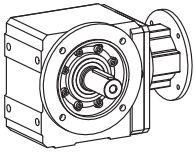

# Beverage Duty – "K" Series – MGS Reducer Round Flange – "F" Housing Shaft Output – Dimensional Data

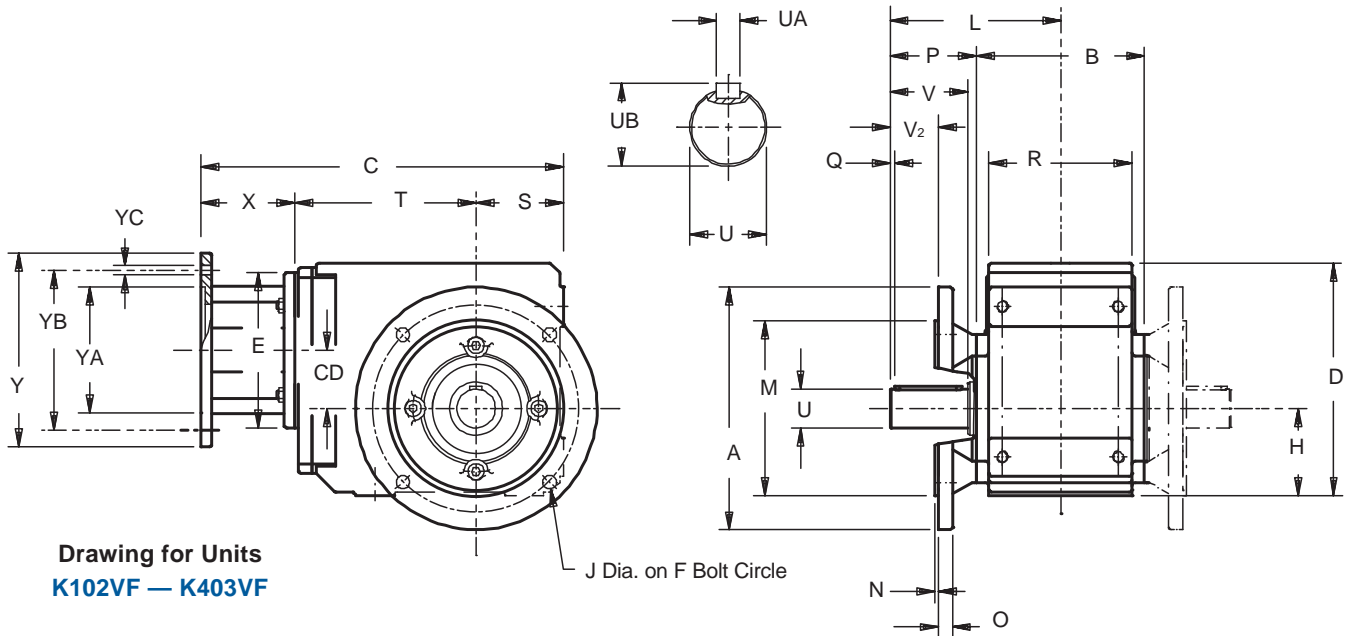

Drawing for Units  
K102VF – K403VF

Table No. 1 Beverage Duty – "K" Series – Round Flange Unit Dimensions (Inches) – "F" Housing Style

Base Module	A	B	D	F	H	J	L	M	N	O	P	Q	R	S	V	V <sub>2</sub>	Z <sub>1</sub>	
K102	6.30	4.17	6.30	5.12	2.36	.35	4.53	4.331	+0.001/-0.0004	.14	.39	2.44	.16	3.54	2.36	1.97	1.18	—
K202/203	7.87	5.28	7.48	6.50	2.56	.43	5.31	5.118	+0.001/-0.0004	.14	.47	2.68	.16	4.53	2.56	2.36	1.42	—
K302/303	7.87	5.75	8.39	6.50	2.95	.43	5.59	5.118	+0.001/-0.0004	.14	.55	2.72	.16	5.12	2.95	2.36	1.22	—
K402/403	9.84	6.81	9.45	8.46	3.54	.55	6.54	7.087	+0.001/-0.0004	.16	.59	3.52	.16	5.83	3.54	2.76	1.95	—
K513/514	9.84	7.28	10.24	8.46	6.30	.55	8.74	7.087	+0.001/-0.0004	.16	.59	5.10	.16	6.30	3.94	3.54	—	5.98
K613/614	11.81	7.87	12.20	10.43	7.48	.55	9.29	9.055	+0.001/-0.001	.16	.67	5.35	.16	6.61	4.72	3.94	—	6.77
K713/714	13.78	8.90	13.46	11.81	8.35	.71	10.91	9.842	+0.000/-0.001	.20	.71	6.46	.16	7.48	4.92	4.72	—	7.52
K813/814	15.75	11.10	16.14	13.78	10.43	.71	12.83	11.811	+0.000/-0.001	.20	.79	7.28	.20	9.25	5.71	5.51	—	8.11

Table No. 2 Motor Adapter Dimensions (Inches)

Motor Adapter	NEMA C-Flange	E	X	Y	YA	YB	YC	Wt. lbs.
MR140/050B	56C	5.51	3.31	6.50	4.500	5.87	.41	9
MR160/050B	56C	6.30	3.86	6.50	4.500	5.87	.41	16
MR160/140B	143/145TC	6.30	3.86	6.50	4.500	5.87	.41	16
MR200/180B	182/184TC	7.87	4.80	9.00	8.500	7.25	.55	23
MR250/180B	182/184TC	9.84	5.31	9.00	8.500	7.25	.55	36
MR250/210B	213/215TC	9.84	5.31	9.00	8.500	7.25	.55	36
MR300/180B	182/184TC	11.81	6.50	9.00	8.500	7.25	.57	75
MR300/210B	213/215TC	11.81	6.50	9.00	8.500	7.25	.57	75
MR300/250B	254/256TC	11.81	6.50	9.00	8.500	7.25	.57	75
MR300/280B	284/286TC	11.81	6.50	11.13	10.500	9.00	.57	75

Table No. 3

Base Module	Standard Shaft – inches		
	U	UA – Key	UB
K102	1.000	1/4 x 1/4 x 1 <sup>9</sup> / <sub>16</sub>	1.11
K202/203	1.250	1/4 x 1/4 x 1 <sup>15</sup> / <sub>16</sub>	1.36
K302/303	1.250	1/4 x 1/4 x 1 <sup>15</sup> / <sub>16</sub>	1.36
K402/403	1.375	5/16 x 5/16 x 2 <sup>5</sup> / <sub>16</sub>	1.51
K513/514	1.750	3/8 x 3/8 x 3 <sup>5</sup> / <sub>32</sub>	1.92
K613/614	1.750	3/8 x 3/8 x 3 <sup>5</sup> / <sub>32</sub>	1.92
K713/714	2.375	5/8 x 5/8 x 3 <sup>15</sup> / <sub>16</sub>	2.65
K813/814	2.875	3/4 x 3/4 x 4 <sup>5</sup> / <sub>16</sub>	3.21

Table No. 4 "K" Series – Optional Flanges (Inches)

Base Module	Flange Size	A	F	J	L	M	N	O
K1	140	5.512	4.53	.35	3.35	3.740	.12	.39
K2	160	6.300	5.12	.35	3.90	4.331	.14	.47
K3	160	6.300	5.12	.35	4.37	4.331	.14	.55
K7	300	11.811	10.43	.55	6.18	9.055	.20	.71
K8	350	13.780	11.81	.71	7.32	9.843	.20	.79
	450	17.717	15.75	.71	7.32	13.781	.20	.79

\* Optional flanges are not available in all sizes.





# Beverage Duty – "K" Series – MGS Reducer Round Flange – "F" Housing Shaft Output – Dimensional Data

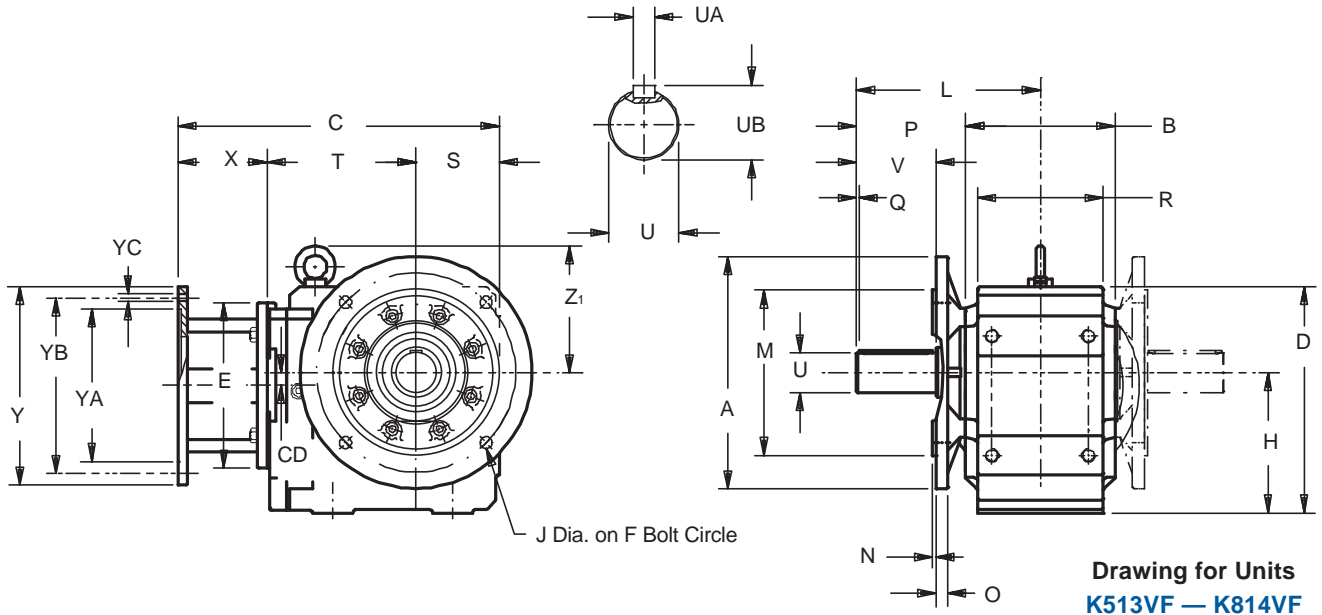
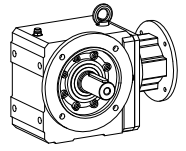

**Table No. 5 Beverage Duty – "K" Series – Dimensions (Inches) – "F" Housing Style**

Base	MR140/050B			MR160/140B <sup>1)</sup>			MR200/180B			MR250/210B <sup>2)</sup>			MR300/250B <sup>3)</sup>			Wt.
Module	CD	C	T	CD	C	T	CD	C	T	CD	C	T	CD	C	T	lbs.
K102	1.42	10.55	4.88	1.42	11.26	5.04	—	—	—	—	—	—	—	—	—	31
K202	1.81	11.50	5.63	1.81	12.21	5.79	1.81	13.23	5.87	—	—	—	—	—	—	40
K203	1.81	12.96	7.09	—	—	—	—	—	—	—	—	—	—	—	—	53
K302	2.07	12.68	6.42	2.07	13.38	6.57	2.07	14.40	6.65	—	—	—	—	—	—	67
K303	2.07	14.13	7.87	.63	15.08	8.27	—	—	—	—	—	—	—	—	—	73
K402	—	—	—	2.36	14.76	7.36	2.36	15.74	7.44	2.36	16.41	7.56	—	—	—	93
K403	2.36	15.51	8.66	.91	16.46	9.06	—	—	—	—	—	—	—	—	—	100
K513	—	—	—	.59	14.57	6.77	.59	15.59	6.85	.59	16.22	6.97	—	—	—	106
K514	—	—	—	.59	16.26	8.46	—	—	—	—	—	—	—	—	—	109
K613	—	—	—	.71	16.10	7.52	.71	17.12	7.60	.71	17.75	7.72	.71	19.49	8.27	170
K614	—	—	—	.71	17.79	9.21	—	—	—	—	—	—	—	—	—	177
K713	—	—	—	—	—	—	.79	18.42	8.70	.79	19.05	8.82	.79	20.75	9.33	221
K714	—	—	—	.79	19.13	10.35	.79	20.86	11.14	—	—	—	—	—	—	234
K813	—	—	—	—	—	—	.94	20.23	9.72	.94	20.82	9.80	.94	22.52	10.31	309
K814	—	—	—	—	—	—	.94	22.64	12.13	—	—	—	—	—	—	331

<sup>1)</sup> Also available as **MR160/050B** for a NEMA 56C frame motor.

<sup>2)</sup> Also available as **MR250/180B** for a NEMA 182/184TC frame motor.

<sup>3)</sup> Also available as **MR300/180B** for a NEMA 182/184TC, **MR300/210B** for a NEMA 213/215TC, and **MR300/280B** for a NEMA 284/286TC frame motor.

All weights are approximate.

### Part No. Example

Beverage Duty  
Round Flange with Motor Adapter

**K303VF0650 MR160/140B**

**Specify: Shaft and Flange Side**

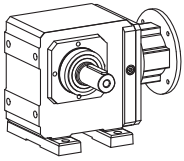

# Beverage Duty – "K" Series – MGS Reducer Foot Mount – "N" Housing Shaft Output – Dimensional Data

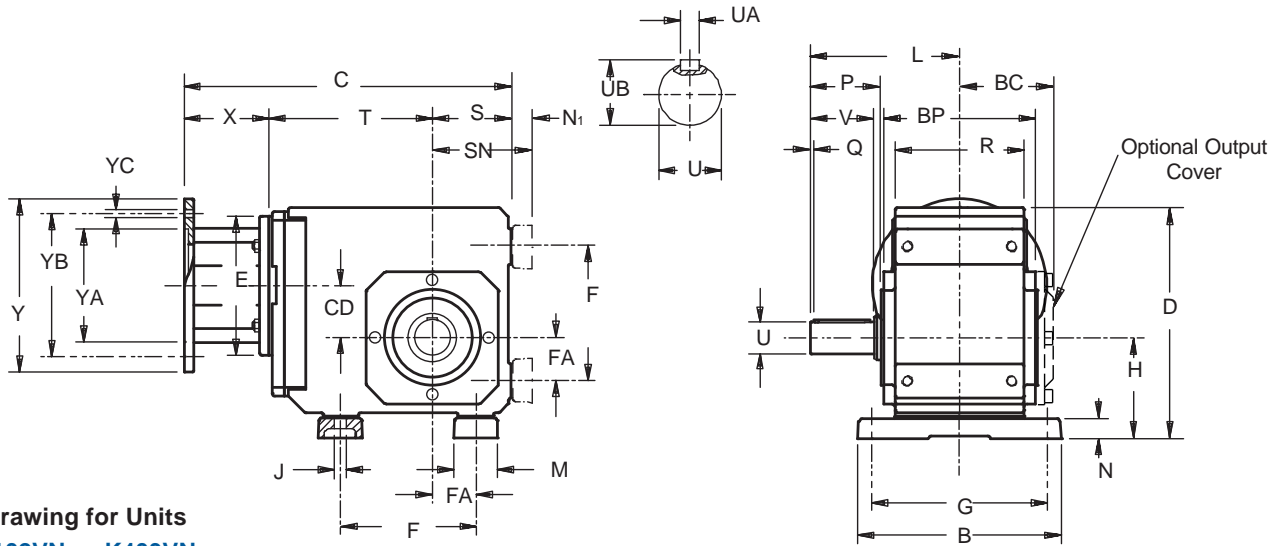

Drawing for Units  
K102VN – K403VN

Table No. 1 Beverage Duty – "K" Series – Foot Mounting Unit Dimensions (Inches) – "N" Housing Style

Base Module	B	D	F	G	H	J	L	M	N	O	P	Q	R	S	V	Z <sub>1</sub>	BC	BP	FA	N <sub>1</sub>	SN
<b>K102</b>	5.51	6.81	3.54 <sup>1)</sup>	4.53	2.95	.35	4.53	1.18	.51	—	2.32	.16	3.54	2.36	1.97	—	2.64	4.17	1.18	.59	2.95
<b>K202/203</b>	7.28	8.39	4.53	6.10	3.46	.43	5.31	1.57	.79	—	2.56	.16	4.53	2.56	2.36	—	3.23	5.28	1.38	.91	3.46
<b>K302/303</b>	7.87	9.29	5.12	6.69	3.86	.43	5.59	1.77	.79	—	2.60	.16	5.12	2.95	2.36	—	3.46	5.75	1.57	.91	3.86
<b>K402/403</b>	9.06	10.43	6.10	7.87	4.53	.55	6.54	1.97	.87	—	3.39	.16	5.83	3.54	2.76	—	4.08	6.81	1.97	.98	4.53
<b>K513/514</b>	9.45	11.42	5.51	7.87	7.48	.71	8.74	2.36	1.06	5.10	3.90	.16	6.30	3.94	3.54	5.98	4.31	7.28	1.57	1.18	5.12
<b>K613/614</b>	9.84	13.39	6.30	8.27	8.66	.71	9.29	2.56	1.06	5.35	4.31	.16	6.61	4.72	3.94	6.77	4.61	7.87	1.97	1.18	5.91
<b>K713/714</b>	11.42	14.96	7.09	9.45	9.84	.87	10.91	2.76	1.38	6.46	5.14	.16	7.48	4.92	4.72	7.52	5.08	8.90	2.17	1.50	6.42
<b>K813/814</b>	14.17	17.91	9.45	11.81	12.20	1.02	12.83	3.35	1.61	7.28	5.94	.20	9.25	5.71	5.51	8.11	6.26	11.10	2.95	1.77	7.48

<sup>1)</sup> Mounting holes are also located on Side 1 of the K1 unit ONLY.

Table No. 2 Motor Adapter Dimensions (Inches)

Motor Adapter	NEMA C-Flange	E	X	Y	YA	YB	YC	Wt. lbs.
<b>MR140/050B</b>	56C	5.51	3.31	6.50	4.500	5.87	.41	9
<b>MR160/050B</b>	56C	6.30	3.86	6.50	4.500	5.87	.41	16
<b>MR160/140B</b>	143/145TC	6.30	3.86	6.50	4.500	5.87	.41	16
<b>MR200/180B</b>	182/184TC	7.87	4.80	9.00	8.500	7.25	.55	23
<b>MR250/180B</b>	182/184TC	9.84	5.31	9.00	8.500	7.25	.55	36
<b>MR250/210B</b>	213/215TC	9.84	5.31	9.00	8.500	7.25	.55	36
<b>MR300/180B</b>	182/184TC	11.81	6.50	9.00	8.500	7.25	.57	75
<b>MR300/210B</b>	213/215TC	11.81	6.50	9.00	8.500	7.25	.57	75
<b>MR300/250B</b>	254/256TC	11.81	6.50	9.00	8.500	7.25	.57	75
<b>MR300/280B</b>	284/286TC	11.81	6.50	11.13	10.500	9.00	.57	75

Table No. 3

Base Module	Standard Shaft – inches		
	U	UA – Key	UB
<b>K102</b>	1.000	1/4 x 1/4 x 1 <sup>9</sup> / <sub>16</sub>	1.11
<b>K202/203</b>	1.250	1/4 x 1/4 x 1 <sup>15</sup> / <sub>16</sub>	1.36
<b>K302/303</b>	1.250	1/4 x 1/4 x 1 <sup>15</sup> / <sub>16</sub>	1.36
<b>K402/403</b>	1.375	5/16 x 3/16 x 2 <sup>5</sup> / <sub>16</sub>	1.51
<b>K513/514</b>	1.750	3/8 x 3/8 x 3 <sup>5</sup> / <sub>32</sub>	1.92
<b>K613/614</b>	1.750	3/8 x 3/8 x 3 <sup>5</sup> / <sub>32</sub>	1.92
<b>K713/714</b>	2.375	5/8 x 5/8 x 3 <sup>15</sup> / <sub>16</sub>	2.65
<b>K813/814</b>	2.875	3/4 x 3/4 x 4 <sup>5</sup> / <sub>16</sub>	3.21

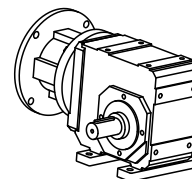

K1 Housing with tapped holes on Side 1, Side 2, and Side 5. Shown with mounting feet on Side 1.



# Beverage Duty – "K" Series – MGS Reducer Foot Mount – "N" Housing Shaft Output – Dimensional Data

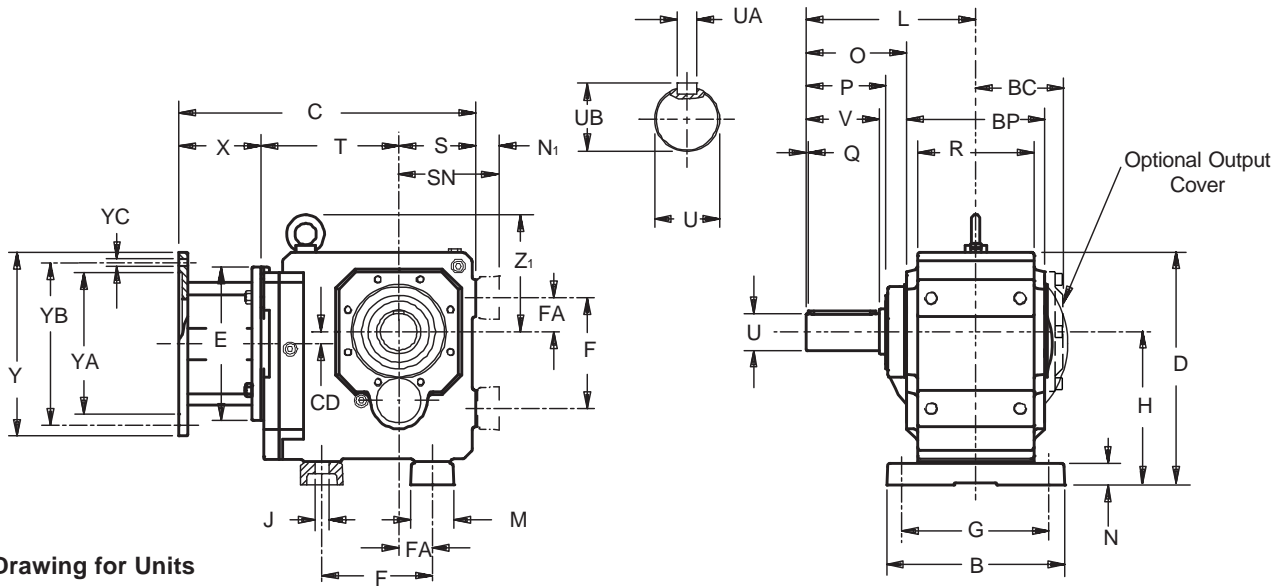
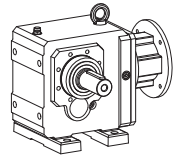

Drawing for Units  
K513VN — K814VN

Table No. 4 Beverage Duty – "K" Series – Foot Mounting Dimensions (Inches) – "N" Housing Style

Base	MR140/050B			MR160/140B <sup>1)</sup>			MR200/180B			MR250/210B <sup>2)</sup>			MR300/250B <sup>3)</sup>			Wt.
Module	CD	C	T	CD	C	T	CD	C	T	CD	C	T	CD	C	T	lbs.
K102	1.42	10.55	4.88	1.42	11.26	5.04	—	—	—	—	—	—	—	—	—	31
K202	1.81	11.50	5.63	1.81	12.21	5.79	1.81	13.23	5.87	—	—	—	—	—	—	40
K203	1.81	12.96	7.09	—	—	—	—	—	—	—	—	—	—	—	—	53
K302	2.07	12.68	6.42	2.07	13.38	6.57	2.07	14.40	6.65	—	—	—	—	—	—	67
K303	2.07	14.13	7.87	.63	15.08	8.27	—	—	—	—	—	—	—	—	—	73
K402	—	—	—	2.36	14.76	7.36	2.36	15.74	7.44	2.36	16.41	7.56	—	—	—	93
K403	2.36	15.51	8.66	.91	16.46	9.06	—	—	—	—	—	—	—	—	—	100
K513	—	—	—	.59	14.57	6.77	.59	15.59	6.85	.59	16.22	6.97	—	—	—	106
K514	—	—	—	.59	16.26	8.46	—	—	—	—	—	—	—	—	—	109
K613	—	—	—	.71	16.10	7.52	.71	17.12	7.60	.71	17.75	7.72	.71	19.49	8.27	170
K614	—	—	—	.71	17.79	9.21	—	—	—	—	—	—	—	—	—	177
K713	—	—	—	—	—	—	.79	18.42	8.70	.79	19.05	8.82	.79	20.75	9.33	221
K714	—	—	—	.79	19.13	10.35	.79	20.86	11.14	—	—	—	—	—	—	234
K813	—	—	—	—	—	—	.94	20.23	9.72	.94	20.82	9.80	.94	22.52	10.31	309
K814	—	—	—	—	—	—	.94	22.64	12.13	—	—	—	—	—	—	331

<sup>1)</sup> Also available as MR160/050B for a NEMA 56C frame motor.

<sup>2)</sup> Also available as MR250/180B for a NEMA 182/184TC frame motor.

<sup>3)</sup> Also available as MR300/180B for a NEMA 182/184TC, MR300/210B for a NEMA 213/215TC, and MR300/280B for a NEMA 284/286TC frame motor.

All weights are approximate.

### Part No. Example

Beverage Duty  
Foot Mounting with Motor Adapter

**K303VN0650 MR160/140B**

**Specify: Shaft and Feet Side**

# Beverage Duty – "C" Series – MGS Reducers Concentric Helical



## Reducer Configurations

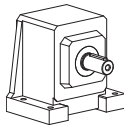

Style N  
Foot Mount

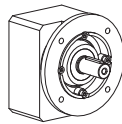

Style F  
Round Flange

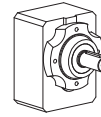

Style G  
Tapped Holes

## Mounting Positions – Standard 3 Year Warranty

One Standard Unit for ALL Horizontal Mounting Positions Without Changing the Oil Level

Standard Oil: Mobile XP600

Optional Oil: Food Grade Oil (Exxon Univis Special Mist 220)

Synthetic Oil (Mobil SHC630)

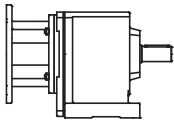

EL1

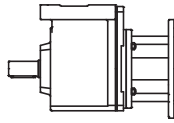

EL2

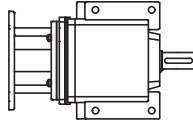

EL3

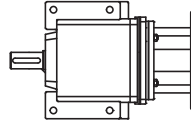

EL4

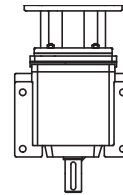

EL5

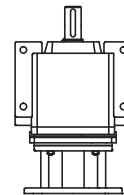

EL6

EL5 and EL6 can be supplied on request.

EL6 is possible but not recommended.

## Mounting Positions – Long Life 5 Year Warranty

Mounting Positions **MUST BE SPECIFIED**

Standard Oil: Synthetic Oil (Mobil SHC630)

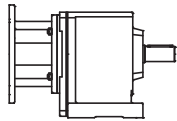

EL12

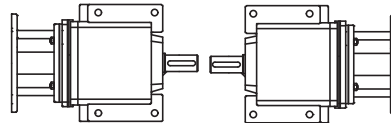
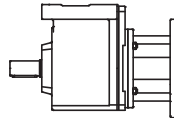

EL34

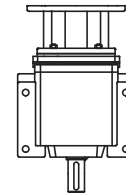

EL5

## Part No. Explanation with OPTIONS

**C 4 0 2 N 0135 MR160 / 140 F LL E34**

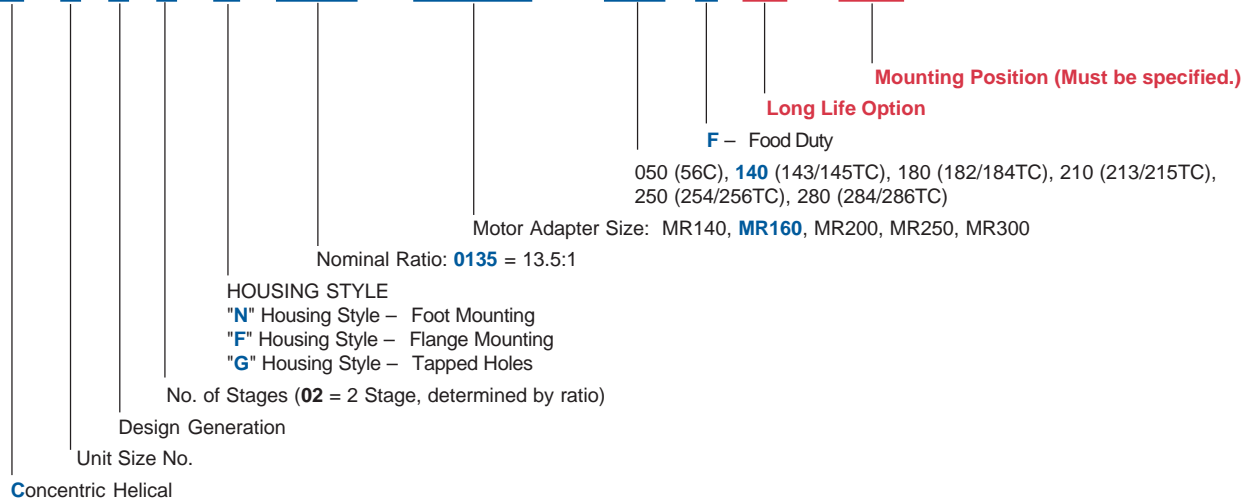

### THE FOLLOWING ARE OPTIONAL FOR SOME UNITS:

- Paint – White ..... Clear Coat
- Oil – Food Grade ..... Synthetic



# Beverage Duty – "C" Series – MGS Reducers Concentric Helical

- Lubricated for Life
- Maintenance Free
- Totally Enclosed (Watertight)
- 3 Year Warranty – your guarantee of our confidence in the MGS (Modular Gear System) line of reducers
- 97% Efficiency – for high quality and reliability plus cost savings in energy and maintenance



- Standard Coating – Industrial 316 Stainless Steel Epoxy  
 Coating Options – Additional Layer Ultra Clear Industrial Epoxy  
 – White Epoxy

Stainless Steel  
Nameplate

- NEMA C-face Input
- O-ring between motor and reducer
  - Easy mount maintenance free coupling

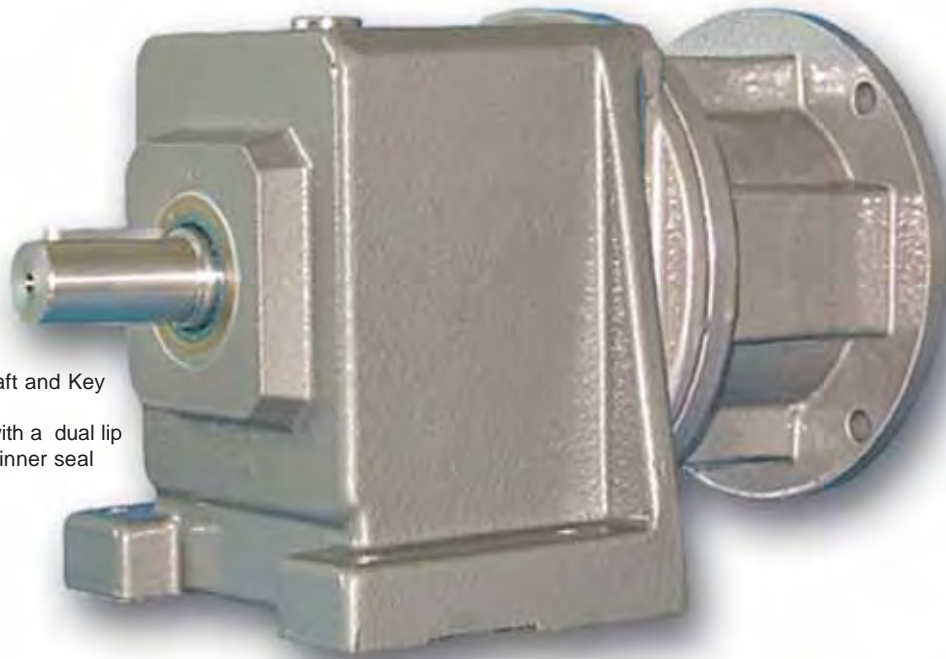

Stainless Steel Output Shaft and Key

Double Sealed Output – with a dual lip  
outer seal and a single lip inner seal

**See Pages 64-91 for Selection Data.**



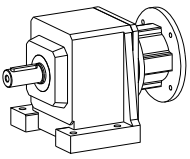

# Beverage Duty – "C" Series – MGS Reducer Foot Mount – "N" Housing Dimensional Data

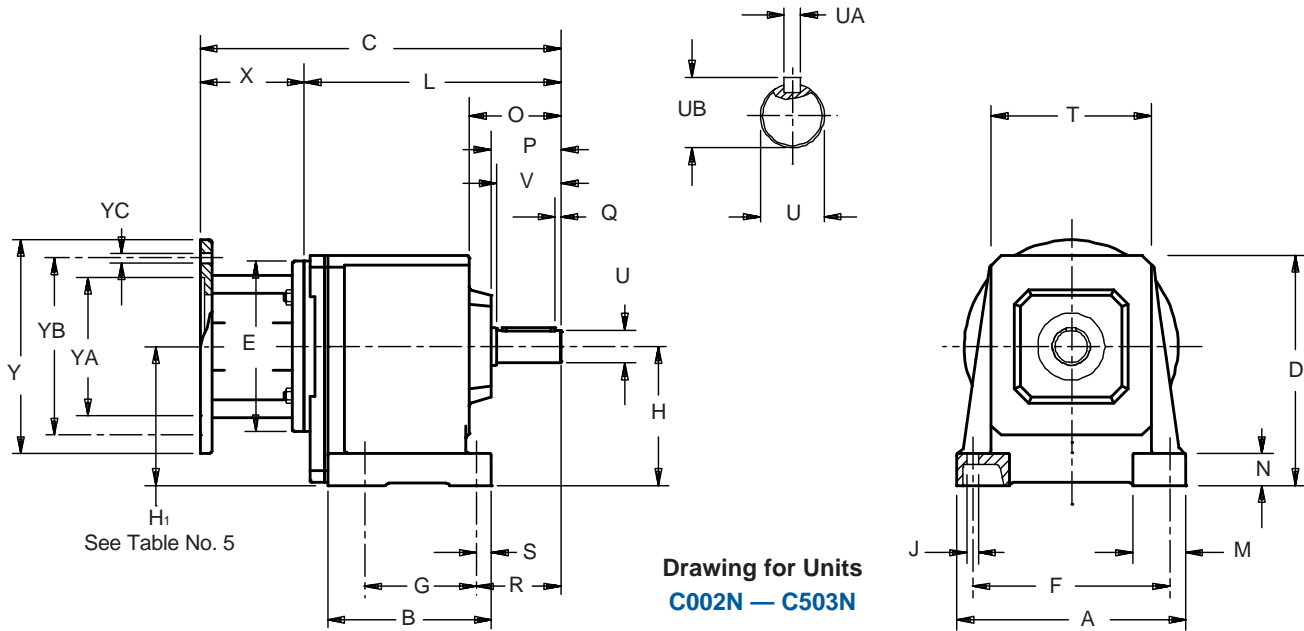

**Table No. 1 "C" Series – Foot Mounting Unit Dimensions (Inches) – "N" Housing Style**

Base Module	A	B	D	F	G	H	J	M	N	O	P	Q	R
<b>C002</b>	5.20	3.74	5.67	4.33	2.44	3.23	.28	1.38	.79	2.24	1.73	.16	2.17
<b>C102/C103</b>	6.93	4.65	6.97	5.91	2.76	4.02	.35	1.65	.98	2.72	2.13	.16	2.64
<b>C202/C203</b>	7.87	5.31	7.68	6.69	3.35	4.53	.43	1.97	1.18	3.39	2.56	.16	3.11
<b>C302/C303</b>	8.46	6.06	8.46	7.28	4.13	5.12 <sup>1)</sup>	.43	1.97	1.18	3.35	2.56	.16	3.11
<b>C402/C403</b>	10.04	7.09	9.65	8.66	4.33	5.71	.55	2.36	1.38	4.17	3.39	.16	4.13
<b>C502/C503</b>	11.42	7.76	11.42	9.65	5.12	6.69	.71	2.76	1.57	4.21	3.39	.16	4.25
<b>C612/C613</b>	11.81	10.43	12.40	9.65	8.46	7.87 <sup>1)</sup>	.71	2.95	1.57	6.02	4.17	.20	5.12

<sup>1)</sup> "See Table No. 5

**Table No. 2**

Base Module	S	T	U	V	Z <sub>1</sub>	UA – Key	UB
<b>C002</b>	.43	3.62	.7500	1.57	—	$\frac{3}{16} \times \frac{3}{16} \times \frac{17}{32}$	.83
<b>C102/C103</b>	.51	4.88	1.0000	1.97	—	$\frac{1}{4} \times \frac{1}{4} \times \frac{9}{16}$	1.11
<b>C202/C203</b>	.55	5.43	1.2500	2.36	—	$\frac{1}{4} \times \frac{1}{4} \times \frac{15}{16}$	1.36
<b>C302/C303</b>	.55	5.91	1.2500	2.36	—	$\frac{1}{4} \times \frac{1}{4} \times \frac{15}{16}$	1.36
<b>C402/C403</b>	.75	6.89	1.6250	3.15	—	$\frac{3}{8} \times \frac{3}{8} \times \frac{27}{8}$	1.79
<b>C502/C503</b>	.87	7.56	1.6250	3.15	—	$\frac{3}{8} \times \frac{3}{8} \times \frac{27}{8}$	1.79
<b>C612/C613</b>	.98	6.97	2.1250	3.94	6.57	$\frac{1}{2} \times \frac{1}{2} \times \frac{35}{32}$	2.35

**Table No. 3**

**"C" Series – Foot Mounting Unit Dimensions (Inches) – "N" Housing Style**

Motor Adapter	NEMA C-Flange	E	X	Y	YA	YB	YC	Wt. lbs.
<b>MR140/050B</b>	56C	5.51	3.31	6.50	4.500	5.87	.41	9
<b>MR160/050B</b>	56C	6.30	3.86	6.50	4.500	5.87	.41	16
<b>MR160/140B</b>	143/145TC	6.30	3.86	6.50	4.500	5.87	.41	16
<b>MR200/180B</b>	182/184TC	7.87	4.80	9.00	8.500	7.25	.55	23
<b>MR250/180B</b>	182/184TC	9.84	5.31	9.00	8.500	7.25	.55	36
<b>MR250/210B</b>	213/215TC	9.84	5.31	9.00	8.500	7.25	.55	36
<b>MR300/180B</b>	182/184TC	11.81	6.50	9.00	8.500	7.25	.57	75
<b>MR300/210B</b>	213/215TC	11.81	6.50	9.00	8.500	7.25	.57	75
<b>MR300/250B</b>	254/256TC	11.81	6.50	9.00	8.500	7.25	.57	75
<b>MR300/280B</b>	284/286TC	11.81	6.50	11.13	10.500	9.00	.57	75



# Beverage Duty – "C" Series – MGS Reducer Foot Mount – "N" Housing Dimensional Data

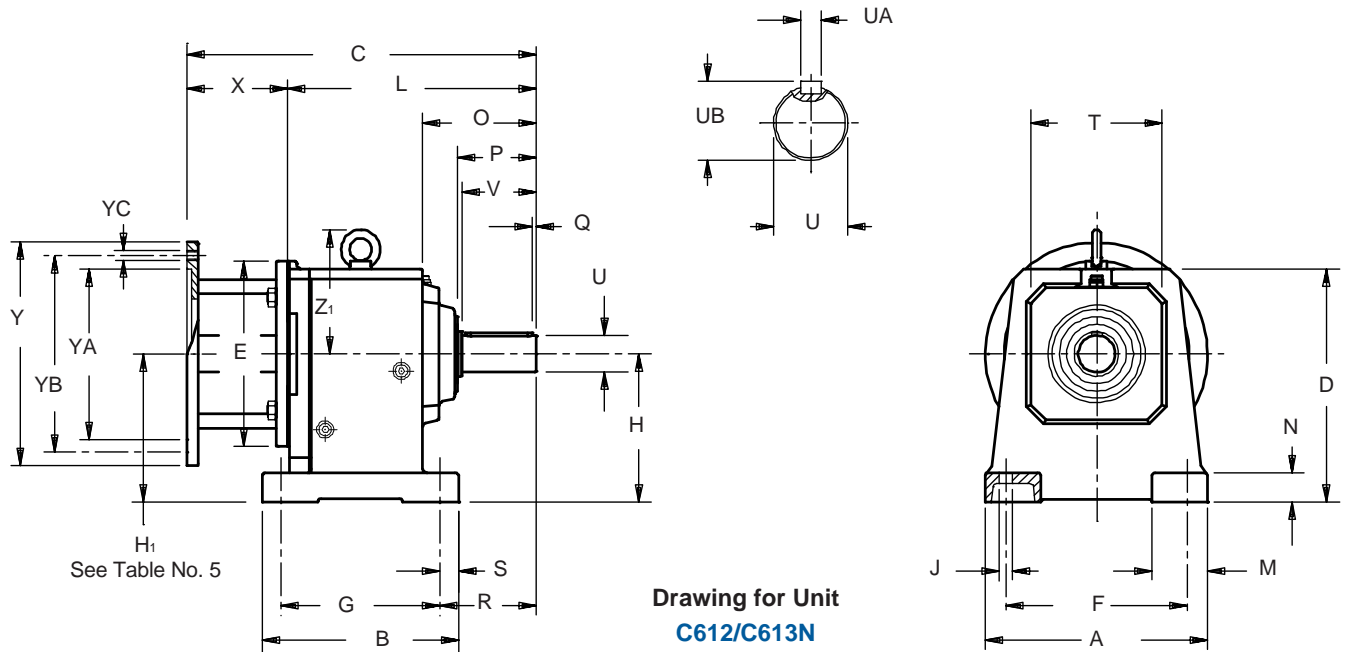
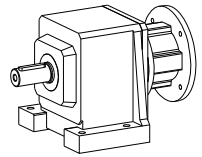

**Table No. 4 "C" Series – Foot Mounting Unit Dimensions (Inches) – "N" Housing Style**

Base Module	MR140/050B		MR160/140B <sup>2)</sup>		MR200/180B		MR250/210B <sup>3)</sup>		MR300/250B <sup>4)</sup>		Approx. Wt.(lbs.)
	C	L	C	L	C	L	C	L	C	L	
<b>C002</b>	9.37	6.06	10.08	6.22	—	—	—	—	—	—	18
<b>C102</b>	10.67	7.36	11.38	7.52	12.40	7.60	—	—	—	—	29
<b>C103</b>	12.13	8.82	—	—	—	—	—	—	—	—	34
<b>C202</b>	11.77	8.46	12.48	8.62	13.50	8.70	—	—	—	—	38
<b>C203</b>	13.23	9.92	14.17	10.31	—	—	—	—	—	—	45
<b>C302</b>	—	—	13.23	9.37	14.25	9.45	14.88	9.57	—	—	49
<b>C303</b> <sup>1)</sup>	13.98	10.67	14.92	11.06	—	—	—	—	—	—	56
<b>C402</b>	—	—	15.12	11.26	16.14	11.34	16.77	11.46	—	—	71
<b>C403</b>	—	—	16.81	12.95	—	—	—	—	—	—	78
<b>C502</b>	—	—	15.95	12.09	16.97	12.17	17.59	12.28	19.33	12.83	95
<b>C503</b>	—	—	17.64	13.78	—	—	—	—	—	—	111
<b>C612</b> <sup>1)</sup>	—	—	—	—	17.91	13.11	18.54	13.23	20.24	13.74	115
<b>C613</b> <sup>1)</sup>	—	—	18.62	14.76	20.35	15.55	—	—	—	—	159

<sup>2)</sup> Also available as **MR160/050B** for a NEMA 56C frame motor.

<sup>3)</sup> Also available as **MR250/180B** for a NEMA 182/184TC frame motor.

<sup>4)</sup> Also available as **MR300/180B** for a NEMA 182/184TC, **MR300/210B** for a NEMA 213/215TC, and **MR300/280B** for a NEMA 284/286TC frame motor.

All weights are approximate.

**Table No. 5 "C" Series – Input Dimension (Inches)**

Base Module	MR160/050B <sup>2)</sup>	MR200/180B	MR250/210B	MR300/250B
	H <sub>1</sub>	H <sub>1</sub>	H <sub>1</sub>	H <sub>1</sub>
<b>C303</b>	3.66	—	—	—
<b>C612</b>	—	7.63	7.63	7.63
<b>C613</b>	—	—	7.63	—

**Part No. Example**  
Beverage Duty Unit  
Foot Mounting with Motor Adapter  
**C302N0620 MR160/140B**

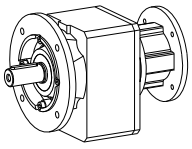

# Beverage Duty – "C" Series – MGS Reducer Round Flange – "F" Housing Dimensional Data

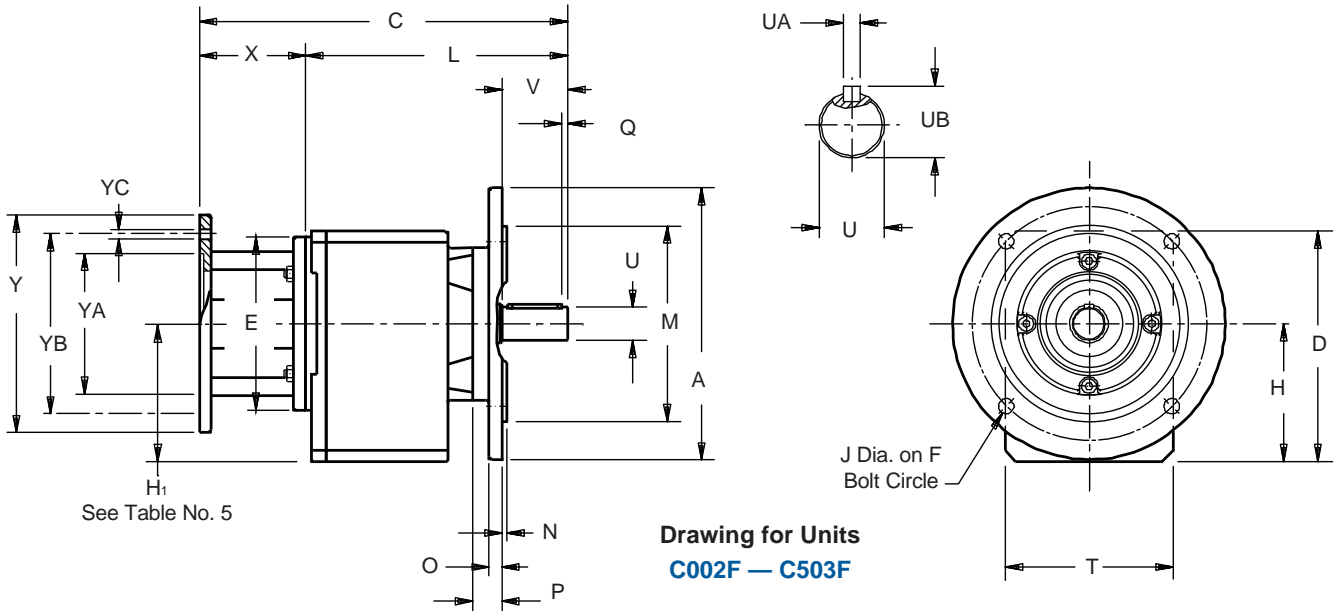

**Drawing for Units  
C002F – C503F**

**Table No. 1 "C" Series – Round Flange Unit Dimensions (Inches) – "F" Housing Style**

Base Module	A	D	F	H	J	M	N	O	P	Q	T	V	Z <sub>1</sub>
<b>C002</b>	6.30	5.55	5.12	3.11	.35	4.331	.12	.39	.71	.16	3.82	1.57	—
<b>C102/C103</b>	7.87	6.89	6.50	3.94	.43	5.118	.14	.47	.83	.16	5.12	1.97	—
<b>C202/C203</b>	7.87	7.56	6.50	4.41	.43	5.118	.14	.47	1.06	.16	5.59	2.36	—
<b>C302/C303</b>	9.84	8.35	8.46	5.00 <sup>1)</sup>	.55	7.087	.16	.47	1.06	.16	6.06	2.36	—
<b>C402/C403</b>	9.84	9.55	8.46	5.61	.55	7.087	.16	.55	1.10	.16	7.01	3.15	—
<b>C502/C503</b>	11.81	11.26	10.43	6.54	.55	9.055	.16	.63	1.14	.16	7.68	3.15	—
<b>C612/C613</b>	11.81	11.97	10.43	7.44 <sup>1)</sup>	.55	9.055	.16	.67	1.42	.20	8.86	3.94	6.57

<sup>1)</sup> See Table No. 5

**Table No. 2 Metric output available on request**

Base Module	Standard Shaft - inches			Optional Shaft - mm		
	U	UA	UB	U	UA	UB
<b>C002</b>	.750	$\frac{3}{16} \times \frac{3}{16} \times 1\frac{7}{32}$	.83	20 <sub>k6</sub>	A6x6x32	22.5
<b>C102/C103</b>	1.000	$\frac{1}{4} \times \frac{1}{4} \times 1\frac{9}{16}$	1.11	25 <sub>k6</sub>	A8x7x40	28
<b>C202/C203</b>	1.250	$\frac{1}{4} \times \frac{1}{4} \times 1\frac{15}{16}$	1.36	30 <sub>k6</sub>	A8x7x50	33
<b>C302/C303</b>	1.250	$\frac{1}{4} \times \frac{1}{4} \times 1\frac{15}{16}$	1.36	30 <sub>k6</sub>	A8x7x50	33
<b>C402/C403</b>	1.625	$\frac{3}{8} \times \frac{3}{8} \times 2\frac{7}{8}$	1.79	40 <sub>k6</sub>	A12x8x70	43
<b>C502/C503</b>	1.625	$\frac{3}{8} \times \frac{3}{8} \times 2\frac{7}{8}$	1.79	40 <sub>k6</sub>	A12x8x70	43
<b>C612/C613</b>	2.125	$\frac{1}{2} \times \frac{1}{2} \times 3\frac{5}{32}$	2.35	50 <sub>k6</sub>	A14x9x90	53.5

**Table No. 3 Motor Adapter Dimensions (Inches)**

Motor Adapter	NEMA C-Flange	E	X	Y	YA	YB	YC	Wt. lbs.
<b>MR140/050B</b>	56C	5.51	3.31	6.50	4.500	5.87	.41	9
<b>MR160/050B</b>	56C	6.30	3.86	6.50	4.500	5.87	.41	16
<b>MR160/140B</b>	143/145TC	6.30	3.86	6.50	4.500	5.87	.41	16
<b>MR200/180B</b>	182/184TC	7.87	4.80	9.00	8.500	7.25	.55	23
<b>MR250/180B</b>	182/184TC	9.84	5.31	9.00	8.500	7.25	.55	36
<b>MR250/210B</b>	213/215TC	9.84	5.31	9.00	8.500	7.25	.55	36
<b>MR300/180B</b>	182/184TC	11.81	6.50	9.00	8.500	7.25	.57	75
<b>MR300/210B</b>	213/215TC	11.81	6.50	9.00	8.500	7.25	.57	75
<b>MR300/250B</b>	254/256TC	11.81	6.50	9.00	8.500	7.25	.57	75
<b>MR300/280B</b>	284/286TC	11.81	6.50	11.13	10.500	9.00	.57	75

**Part No. Example**  
Beverage Duty Unit  
Round Flange with Motor Adapter  
**C302F0620 MR160/140B**



# Beverage Duty – "C" Series – MGS Reducer Round Flange – "F" Housing Dimensional Data

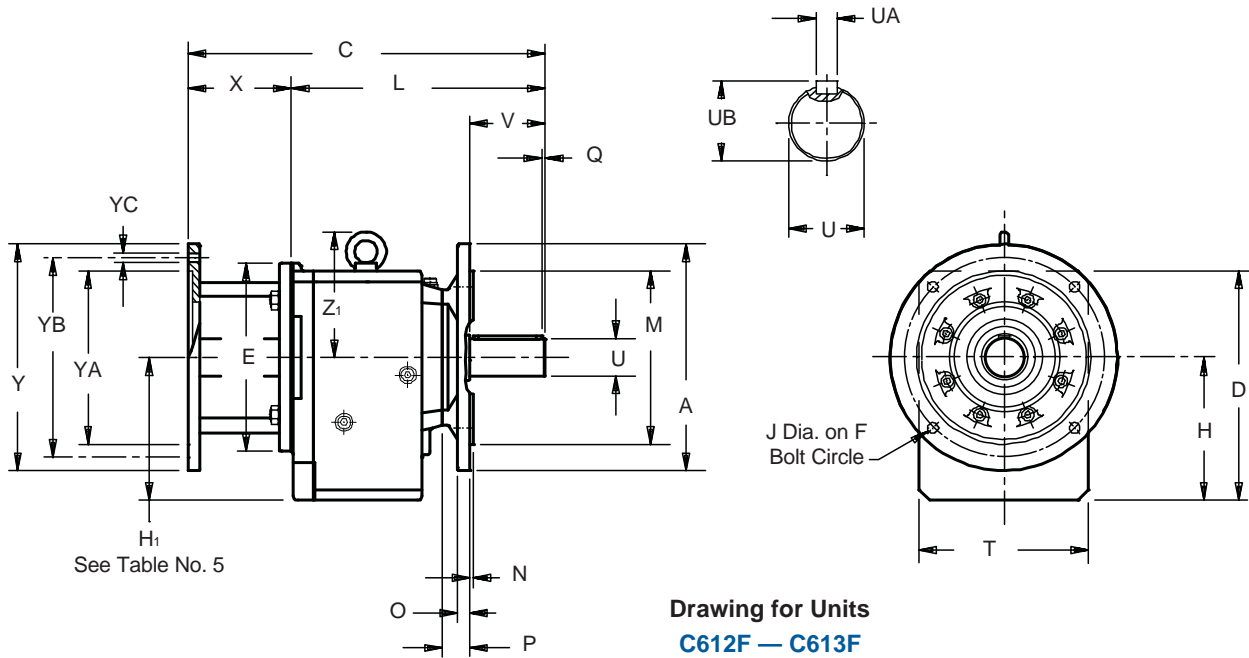
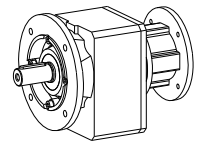

Drawing for Units  
C612F – C613F

Table No. 4 Beverage Duty "C" Series – Dimensions (Inches) – "F" Housing Style

Base Module	MR140/050B		MR160/140B <sup>2)</sup>		MR200/180B		MR250/210B <sup>3)</sup>		MR300/250B <sup>4)</sup>		Approx. Wt.(lbs.)
	C	L	C	L	C	L	C	L	C	L	
C002	9.37	6.06	10.08	6.22	—	—	—	—	—	—1.8	
C102	10.67	7.36	11.38	7.52	12.40	7.60	—	—	—	—2.9	
C103	12.13	8.82	—	—	—	—	—	—	—	—	34
C202	11.77	8.46	12.48	8.62	13.50	8.70	—	—	—	—	38
C203	13.23	9.92	14.17	10.31	—	—	—	—	—	—	45
C302	—	—	13.23	9.37	14.25	9.45	14.88	9.57	—	—	49
C303 <sup>1)</sup>	13.98	10.67	14.92	11.06	—	—	—	—	—	—	56
C402	—	—	15.12	11.26	16.14	11.34	16.77	11.46	—	—	71
C403	—	—	16.81	12.95	—	—	—	—	—	—	78
C502	—	—	15.95	12.09	16.97	12.17	17.59	12.28	19.33	12.83	95
C503	—	—	17.64	13.78	—	—	—	—	—	—	111
C612 <sup>1)</sup>	—	—	—	—	17.91	13.11	18.54	13.23	20.24	13.74	115
C613 <sup>1)</sup>	—	—	18.62	14.76	20.35	15.55	—	—	—	—	159

<sup>1)</sup> See Table No. 5.

<sup>2)</sup> Also available as MR160/050B for a NEMA 56C frame motor.

<sup>3)</sup> Also available as MR250/180B for a NEMA 182/184TC frame motor.

<sup>4)</sup> Also available as MR300/180B for a NEMA 182/184TC, MR300/210B for a NEMA 213/215TC, and MR300/280B for a NEMA 284/286TC frame motor.

All weights are approximate.

Table No. 5 "C" Series – Input Dimension (Inches)

Base Module	MR160/140B <sup>2)</sup>	MR200/180B	MR250/210B	MR300/250B
	H <sub>1</sub>	H <sub>1</sub>	H <sub>1</sub>	H <sub>1</sub>
C303	3.54	—	—	—
C612	—	7.44	7.44	7.44
C613	—	—	7.44	—

Table No. 6 Optional Flange—Dimensions (Inches)

Base Module	Flange Size	A	F	J	M	N	O
C0	120	4.724	3.93	.28	3.150	+0.01/-0.004	.12 .39
	140	5.512	4.53	.35	3.740	+0.01/-0.004	.12 .39
C1	140	5.512	4.53	.35	3.740	+0.01/-0.004	.14 .32
	160	6.300	5.12	.35	4.331	+0.01/-0.004	.14 .39
C2	160	6.300	5.12	.35	4.331	+0.01/-0.004	.14 .39
	250	9.843	8.46	.55	7.087	+0.01/-0.004	.16 .47
C3	160	6.300	5.12	.35	4.331	+0.01/-0.004	.14 .39
	200	7.874	6.50	.43	5.118	+0.01/-0.004	.14 .47
C4	200	7.874	6.50	.43	5.118	+0.01/-0.004	.16 .55
	300	11.811	10.43	.55	9.055	+0.01/-0.001	.16 .55
C5	250	9.843	8.46	.55	7.087	+0.01/-0.004	.16 .55

Optional flanges are not available in all sizes.

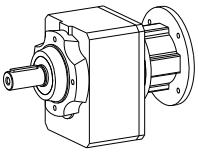

# Beverage Duty – "C" Series – MGS Reducer Tapped Holes – "G" Housing Dimensional Data

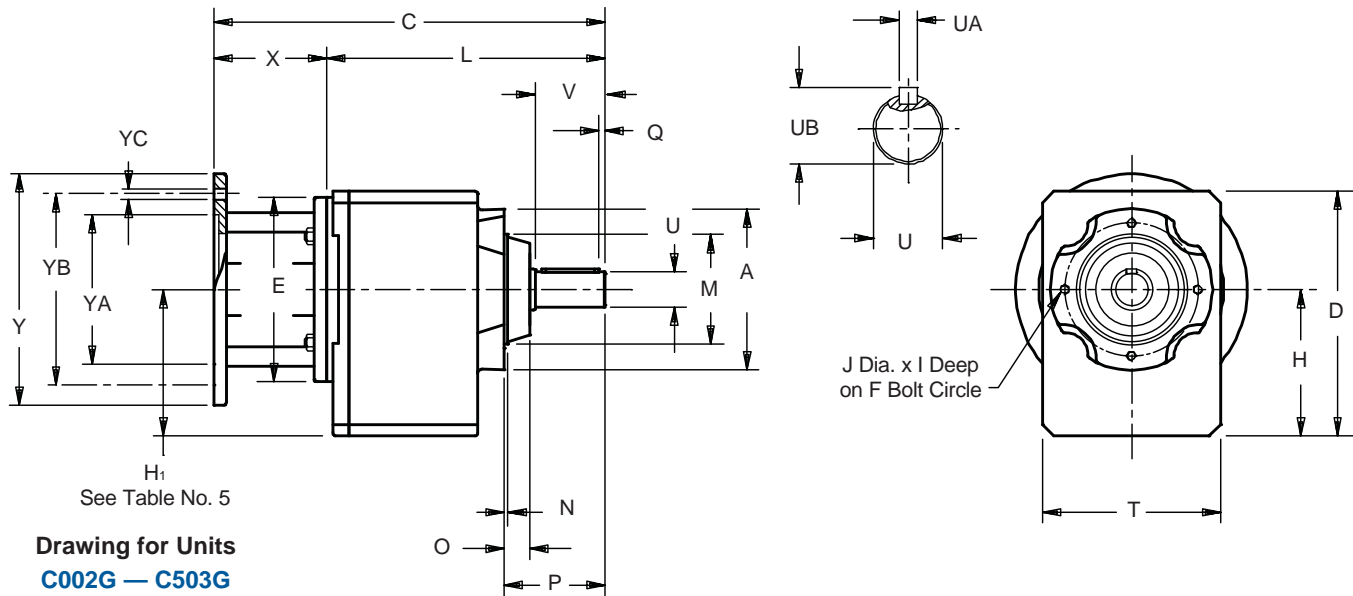

**Table No. 1 Beverage Duty "C" Series – Tapped Holes Unit Dimensions (Inches) – "G" Housing Style**

Base Module	A	D	F	H	I	J	M	N	O	P	Q	T	V	Z <sub>1</sub>
<b>C002</b>	3.43	5.55	2.95	3.11	.39	M6	2.165	.12	.55	2.28	.16	3.82	1.57	—
<b>C102/C103</b>	4.72	6.89	3.94	3.94	.51	M6	3.150	.12	.67	2.80	.16	5.12	1.97	—
<b>C202/C203</b>	5.51	7.56	4.53	4.41	.51	M8	3.740	.12	.87	3.43	.16	5.59	2.36	—
<b>C302/C303</b>	5.51	8.35	4.53	5.00 <sup>1)</sup>	.51	M8	3.740	.12	.87	3.43	.16	6.06	2.36	—
<b>C402/C403</b>	6.30	9.55	5.12	5.61	.63	M10	4.331	.14	.87	4.25	.16	7.01	3.15	—
<b>C502/C503</b>	7.56	11.26	6.50 <sup>2)</sup>	6.54	.63	M10	5.118	.14	.91	4.29	.16	7.68	3.15	—
<b>C612/C613</b>	7.09	11.97	6.50	7.44 <sup>1)</sup>	.63	M10	5.512	.20	1.18	5.35	.20	8.86	3.94	6.57

<sup>1)</sup> See Table No. 5

<sup>2)</sup> C502/C503 has 8 holes instead of 4 as shown in the drawing.

**Table No. 2 Metric output available on request**

Base Module	Standard Shaft - inches			Optional Shaft - mm		
	U	UA	UB	U	UA	UB
<b>C002</b>	.750	3/16 x 3/16 x 17/32	.83	20 <sub>k6</sub>	A6x6x32	22.5
<b>C102/C103</b>	1.000	1/4 x 1/4 x 19/16	1.11	25 <sub>k6</sub>	A8x7x40	28
<b>C202/C203</b>	1.250	1/4 x 1/4 x 115/16	1.36	30 <sub>k6</sub>	A8x7x50	33
<b>C302/C303</b>	1.250	1/4 x 1/4 x 115/16	1.36	30 <sub>k6</sub>	A8x7x50	33
<b>C402/C403</b>	1.625	3/8 x 3/8 x 27/8	1.79	40 <sub>k6</sub>	A12x8x70	43
<b>C502/C503</b>	1.625	3/8 x 3/8 x 27/8	1.79	40 <sub>k6</sub>	A12x8x70	43
<b>C612/C613</b>	2.125	1/2 x 1/2 x 35/32	2.35	50 <sub>k6</sub>	A14x9x90	53.5
<b>C712/C713</b>	2.375	5/8 x 5/8 x 315/16	2.65	60 <sub>m6</sub>	A18x11x100	64
<b>C812/C813</b>	2.875	3/4 x 3/4 x 45/16	3.21	70 <sub>m6</sub>	A20x12x125	74.5
<b>C912/C913</b>	3.625	7/8 x 7/8 x 51/2	4.01	90 <sub>m6</sub>	A25x14x140	95

**Table No. 3 Motor Adapter Dimensions (Inches)**

Motor Adapter	NEMA C-Flange	E	X	Y	YA	YB	YC	Wt. lbs.
<b>MR140/050B</b>	56C	5.51	3.31	6.50	4.500	5.87	.41	9
<b>MR160/050B</b>	56C	6.30	3.86	6.50	4.500	5.87	.41	16
<b>MR160/140B</b>	143/145TC	6.30	3.86	6.50	4.500	5.87	.41	16
<b>MR200/180B</b>	182/184TC	7.87	4.80	9.00	8.500	7.25	.55	23
<b>MR250/180B</b>	182/184TC	9.84	5.31	9.00	8.500	7.25	.55	36
<b>MR250/210B</b>	213/215TC	9.84	5.31	9.00	8.500	7.25	.55	36
<b>MR300/180B</b>	182/184TC	11.81	6.50	9.00	8.500	7.25	.57	75
<b>MR300/210B</b>	213/215TC	11.81	6.50	9.00	8.500	7.25	.57	75
<b>MR300/250B</b>	254/256TC	11.81	6.50	9.00	8.500	7.25	.57	75
<b>MR300/280B</b>	284/286TC	11.81	6.50	11.13	10.500	9.00	.57	75





# Beverage Duty – "C" Series – MGS Reducer Tapped Holes– "G" Housing Dimensional Data

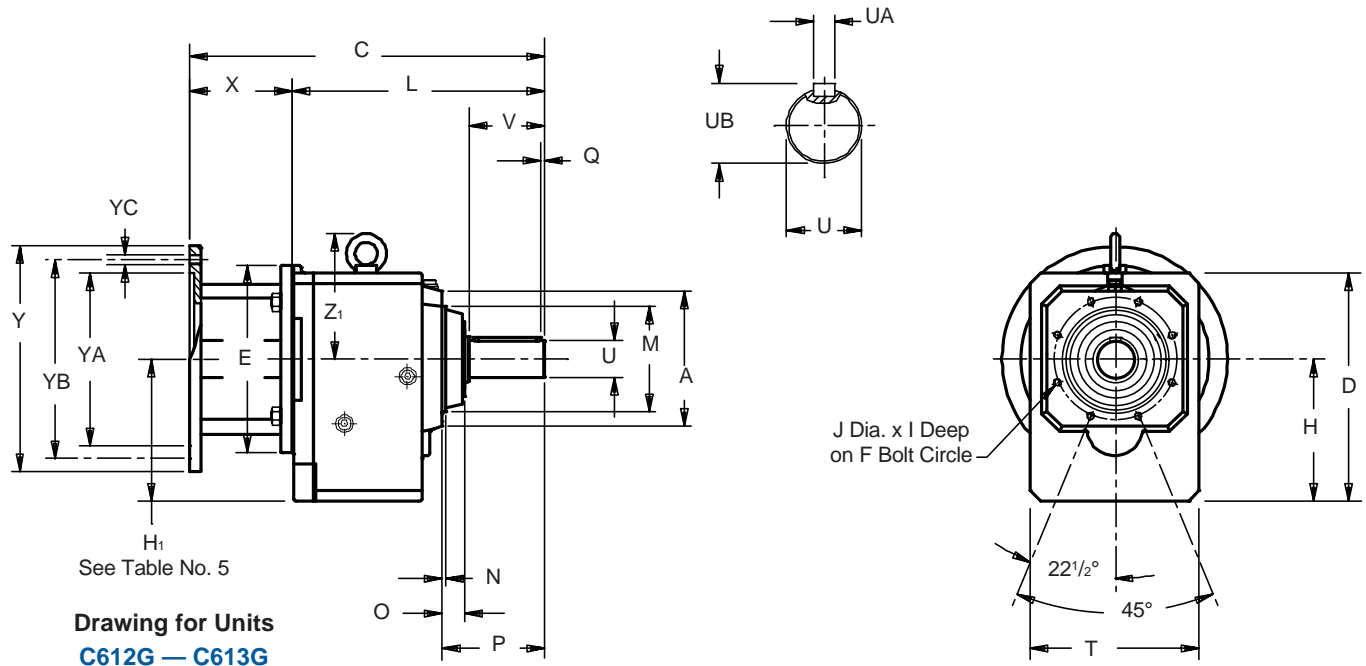
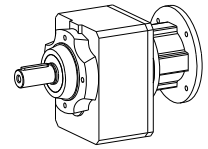

**Table No. 4 Beverage Duty "C" Series – "G" Housing Style – Dimensions (Inches)**

Base Module	MR140/050B		MR160/140B <sup>3)</sup>		MR200/180B		MR250/210B <sup>4)</sup>		MR300/250B <sup>5)</sup>		Approx. Wt.(lbs)
	C	L	C	L	C	L	C	L	C	L	
<b>C002</b>	9.37	6.06	10.08	6.22	—	—	—	—	—	—	18
<b>C102</b>	10.67	7.36	11.38	7.52	12.40	7.60	—	—	—	—	29
<b>C103</b>	12.13	8.82	—	—	—	—	—	—	—	—	34
<b>C202</b>	11.77	8.46	12.48	8.62	13.50	8.70	—	—	—	—	38
<b>C203</b>	13.23	9.92	14.17	10.31	—	—	—	—	—	—	45
<b>C302</b>	—	—	13.23	9.37	14.25	9.45	14.88	9.57	—	—	49
<b>C303</b> <sup>1)</sup>	13.98	10.67	14.92	11.06	—	—	—	—	—	—	56
<b>C402</b>	—	—	15.12	11.26	16.14	11.34	16.77	11.46	—	—	71
<b>C403</b>	—	—	16.81	12.95	—	—	—	—	—	—	78
<b>C502</b>	—	—	15.95	12.09	16.97	12.17	17.59	12.28	19.33	12.83	95
<b>C503</b>	—	—	17.64	13.78	—	—	—	—	—	—	111
<b>C612</b> <sup>1)</sup>	—	—	—	—	17.91	13.11	18.54	13.23	20.24	13.74	115
<b>C613</b> <sup>1)</sup>	—	—	18.62	14.76	20.35	15.55	—	—	—	—	159

<sup>1)</sup> See Table No. 5

<sup>3)</sup> Also available as **MR160/050B** for a NEMA 56C frame motor.

<sup>4)</sup> Also available as **MR250/180B** for a NEMA 182/184TC frame motor.

<sup>5)</sup> Also available as **MR300/180B** for a NEMA 182/184TC, **MR300/210B** for a NEMA 213/215TC, and **MR300/280B** for a NEMA 284/286TC frame motor.

**Table No. 5 "C" Series – Input Dimension (Inches)**

Base Module	MR160/140B <sup>3)</sup>	MR200/180B	MR250/210B	MR300/250B
	H <sub>1</sub>	H <sub>1</sub>	H <sub>1</sub>	H <sub>1</sub>
<b>C303</b>	3.54	—	—	—
<b>C612</b>	—	7.44	7.44	7.44
<b>C613</b>	—	—	7.44	—

**Part No. Example**

Beverage Duty  
Tapped Holes Housing with Motor Adapter

**C302G0620 MR160/140B**

See pages 8-35 for MGS Reducer Selection Data and available ratios.  
All weights are approximate.



# "C" Series Concentric Helical Speed Reducers

3 YEAR WARRANTY STANDARD



5 YEAR WARRANTY OPTIONAL

**3-DAY  
DELIVERY**



[www.stober.com](http://www.stober.com)

# "C" Series—Concentric Helical MGS Reducers



These versatile gear drives offer you performance, durability, and economy for a wide range of constant speed applications. High efficiency helical gearing keeps motor size to a minimum while conserving energy.

### Performance Specifications:

- Horsepower ratings from 1/8 to 165
- Output torques to 62,000 in. lbs.
- Output speeds available from 875 to 6.3 RPM
- Speed reducer ratios from 2.0:1 to 276:1
- 3 year warranty – your assurance of satisfactory product performance

Shipped with the proper amount and type of oil to prevent gear damaging dry start-ups

### Input Options:

- Input shaft
- NEMA C-face Adapter (coupling type)

Strategically located oil fill, drain and breather ports for optimum mounting flexibility. Oil sight glass available.

Stainless steel nameplate and hardware

High quality helical gearing is case hardened to 58-62 Rockwell C. Precision finished for low noise and long service life. Standard backlash is  $\leq 20$  arc minutes

Cast mounting feet provide rigid support and prolonged alignment with driven equipment

High tensile strength shafts with captured keys

Double lip seals keep oil in and contaminants out. Double seals available for severe duty applications.

Available with a one-piece cast iron housing. Precision machined bearing supports assure gearset alignment, prolongs bearing life, provides exceptional overhung load capacities to eliminate leakage problems common to drives with bolt-on output covers.



STOBER Drives Inc. • MGS2007 • [www.stober.com](http://www.stober.com)



MEX (55) 53 63 23 31 MTY (81) 83 54 10 18  
QRO (442) 1 95 72 60 [ventas@industrialmagza.com](mailto:ventas@industrialmagza.com)





# "C" Series—Concentric Helical MGS Speed Reducers Overview

**Housing Style + Input Style = Reducer Configurations**

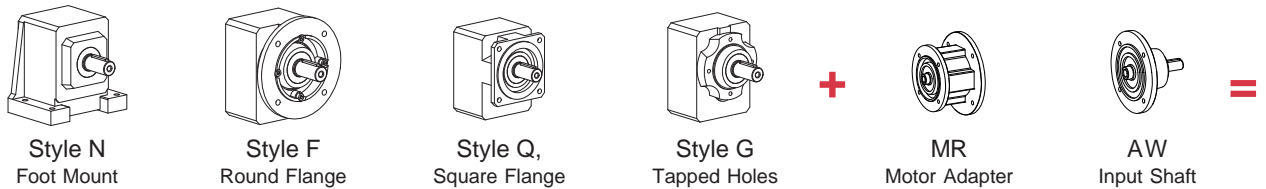

**Reducer Configurations** (See Page 170 for AW Input Shaft.)



**Mounting Positions – Standard 3 Year Warranty**

**Mounting Positions MUST BE SPECIFIED.** (See Page 180 for more details.)

Standard Oil: Mobile XP600

Optional Oil: Food Grade Oil (Exxon Univas Special Mist 220)

Synthetic Oil (Mobil SHC630)

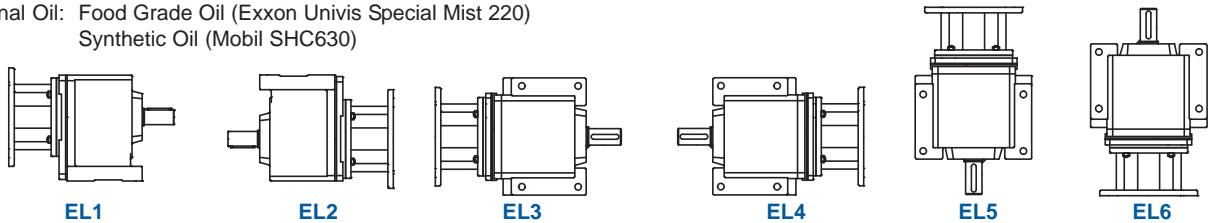

**Mounting Positions – Long Life 5 Year Warranty**

**Mounting Positions MUST BE SPECIFIED.** (See Page 180 for more details.)

Standard Oil: Synthetic Oil (Mobil SHC630)

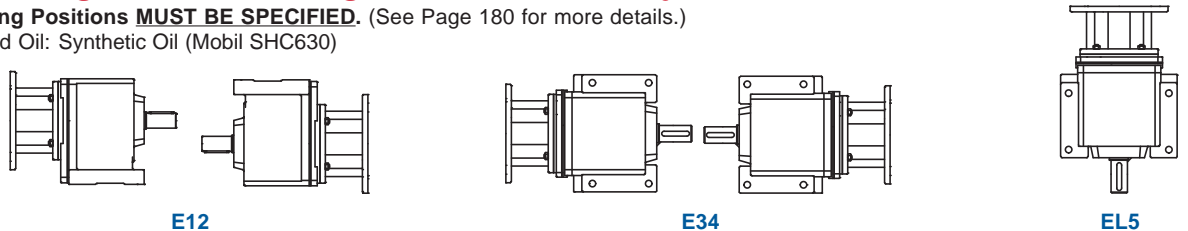

**Part No. Explanation with OPTIONS**

**C 4 0 2 N 0135 MR160 / 140 LL E34**

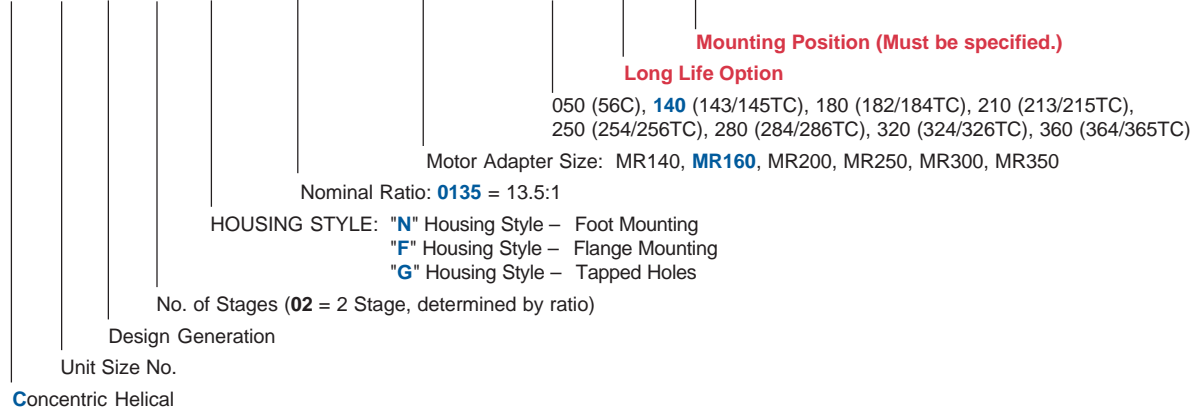

**THE FOLLOWING INFORMATION IS REQUIRED FOR ANY UNIT:**

- Mounting Position – EL1 EL2 EL3 EL4 EL5 EL6 E12 E34
- Paint – Standard Gray, White, Stainless
- Option – Imperial or Metric Shaft (Metric not available in all sizes.)



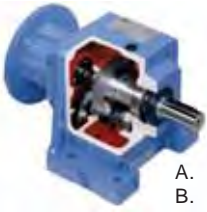

# "C" Series – Concentric Helical MGS Reducer – Selection Data



### Selection Procedure:

- Under the Input RPM heading, find **Approximate Output RPM** nearest the requirement.
- In the **Input HP** column locate the rating that is greater than or equal to the required HP. (If selection is based on Torque instead of HP, find an **Output Torque** that is equal to or greater than required.)
- When HP or Torque rating is located, read across that row to select the **Base Module**, **Input Option** and **Overhung Loads**.
- If exact **Output RPM** is required, divide the **Input RPM** by the **Exact Ratio**.

1750 RPM Input		Base Module <sup>1)</sup>	Input Options <sup>2)</sup>			Exact Ratio	Overhung Load Output Shaft <sup>3)</sup> lbs.	1450 RPM Input		1160 RPM Input		870 RPM Input	
Input HP	Output Torque in. lbs.		Motor Adapter	NEMA C-Frame Size <sup>4)</sup>	Input Shaft			Input HP	Output Torque in. lbs.	Input HP	Output Torque in. lbs.	Input HP	Output Torque in. lbs.
<b>875 RPM Output (Approximate)</b>													
								<b>715 RPM</b>	<b>580 RPM</b>	<b>435 RPM</b>			
2.64	184	C002_0020	MR140/050	56C	AW140/010	1.997	166	2.19	184	1.75	184	1.31	184
2.78	196	C102_0020	MR140/050	56C	AW140/010	2.018	237	2.30	196	1.84	196	1.38	196
4.08*	285	C002_0020	MR160/050	56C	AW160/012	1.997	166	3.60	303	3.10	327	2.47	347
4.08*	285	C002_0020	MR160/140	143/145TC	AW160/012	1.997	166	3.60	303	3.10	327	2.47	347
8.11*	572	C102_0020	MR160/050	56C	AW160/012	2.018	237	7.15	609	6.16	655	4.89	694
8.11*	572	C102_0020	MR160/140	143/145TC	AW160/012	2.018	237	7.15	609	6.16	655	4.89	694
8.11*	572	C102_0020	MR200/180	182/184/TC	AW200/014	2.018	237	7.15	609	6.16	655	5.09	721
9.84*	690	C202_0020	MR160/050	56C	AW160/012	2.009	333	8.15	690	6.52	690	4.89	690
9.84*	690	C202_0020	MR160/140	143/145TC	AW160/012	2.009	333	8.15	690	6.52	690	4.89	690
9.84	694	C302_0020	MR160/050	56C	AW160/012	2.020	496	8.15	694	6.52	694	4.89	694
9.84	694	C302_0020	MR160/140	143/145TC	AW160/012	2.020	496	8.15	694	6.52	694	4.89	694
12.42*	872	C202_0020	MR200/180	182/184/TC	AW200/014	2.009	333	10.95	928	9.44	1,000	7.79	1,100
20.25*	1,429	C302_0020	MR200/180	182/184/TC	AW200/014	2.020	496	17.86	1,522	15.39	1,639	11.61	1,649
20.25*	1,429	C302_0020	MR250/180	182/184/TC	AW250/102	2.020	496	17.86	1,522	15.39	1,639	12.71	1,804
23.36*	1,613	C502_0020	MR200/180	182/184/TC	AW200/014	1.976	1,038	19.36	1,613	15.48	1,613	11.61	1,613
23.36*	1,606	C402_0020	MR200/180	182/184/TC	AW200/014	1.968	845	19.36	1,606	15.48	1,606	11.61	1,606
29.97*	2,061	C402_0020	MR250/180	182/184/TC	AW250/102	1.968	845	26.44	2,194	22.78	2,364	17.48	2,418
36.44*	2,516	C502_0020	MR250/210	213/215/TC	AW250/102	1.976	1,038	30.19	2,516	24.15	2,516	18.11	2,516
46.33*	3,199	C502_0020	MR300/180	182/184/TC	AW300/110	1.976	1,038	40.87	3,406	35.22	3,669	29.07	4,038

<b>800 RPM Output (Approximate)</b>													
								<b>650 RPM</b>	<b>525 RPM</b>	<b>400 RPM</b>			
2.78	211	C102_0022	MR140/050	56C	AW140/010	2.177	241	2.30	211	1.84	211	1.38	211
7.71*	586	C102_0022	MR160/050	56C	AW160/012	2.177	241	6.80	624	5.86	672	4.84	740
7.71*	586	C102_0022	MR160/140	143/145TC	AW160/012	2.177	241	6.80	624	5.86	672	4.84	740
7.71*	586	C102_0022	MR200/180	182/184/TC	AW200/014	2.177	241	6.80	624	5.86	672	4.84	740
9.84*	751	C202_0022	MR160/050	56C	AW160/012	2.184	340	8.15	751	6.52	751	4.89	751
9.84*	751	C202_0022	MR160/140	143/145TC	AW160/012	2.184	340	8.15	751	6.52	751	4.89	751
9.84	748	C302_0022	MR160/050	56C	AW160/012	2.177	505	8.15	748	6.52	748	4.89	748
9.84	748	C302_0022	MR160/140	143/145TC	AW160/012	2.177	505	8.15	748	6.52	748	4.89	748
11.74*	896	C202_0022	MR200/180	182/184/TC	AW200/014	2.184	340	10.36	954	8.93	1,028	7.37	1,131
19.26*	1,465	C302_0022	MR200/180	182/184/TC	AW200/014	2.177	505	16.99	1,560	14.65	1,681	11.61	1,777
19.26*	1,465	C302_0022	MR250/180	182/184/TC	AW250/102	2.177	505	16.99	1,560	14.65	1,681	12.09	1,850
23.36*	1,813	C402_0022	MR200/180	182/184/TC	AW200/014	2.221	871	19.36	1,813	15.48	1,813	11.61	1,813
23.36*	1,834	C502_0022	MR200/180	182/184/TC	AW200/014	2.247	1,072	19.36	1,834	15.48	1,834	11.61	1,834
27.65*	2,146	C402_0022	MR250/180	182/184/TC	AW250/102	2.221	871	24.39	2,285	21.02	2,461	17.35	2,709
36.44*	2,861	C502_0022	MR250/180	182/184/TC	AW250/102	2.247	1,072	30.19	2,861	24.15	2,861	18.11	2,861
42.53*	3,339	C502_0022	MR300/210	213/215/TC	AW300/110	2.247	1,072	37.51	3,555	32.33	3,829	26.69	4,215

\* For thermal HP capacity, see rating below.

Base Module	C0	C1	C2	C3	C4	C5	C6	C7	C8	C9
Thermal Capacity	2.95	5.36	7.38	12.34	14.75	20.12	29.50	40.23	53.64	67.05

NEMA Frame Size  
TEFC 1750 RPM

C-Frame	Motor HP
56C	1/3 - 1 1/2
143/145TC	1, 1 1/2, 2
182/184TC	3, 5
213/215TC	7 1/2, 10
254/256TC	15, 20
284/286TC	25, 30
324/326TC	40, 50
364/365TC	60, 75

### Housing Styles

N – Foot Mounted    F – Round Flange    Q – Square Flange    G – Tapped Holes

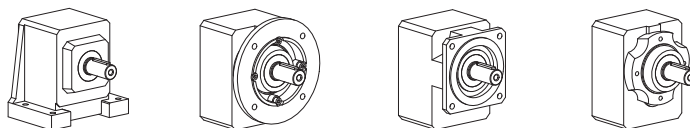

Housing Style Q is available on special order.



# "C" Series – Concentric Helical MGS Reducer – Selection Data



- NOTE:** 1) Complete Base Module Part Number by adding Housing Style. Example: C302N0560.  
 2) Select Input Option and add to completed Part Number. See example below.  
 3) Overhung Load is measured at the center of the shaft extension. Hollow output units are not intended to support overhung loads. If a load rating is required, use 50% of the published overhung load.  
 4) Other frame sizes may also be available. See dimension pages.

1750 RPM Input		Base Module <sup>1)</sup>	Input Options <sup>2)</sup>			Exact Ratio	Overhung Load Output Shaft <sup>3)</sup> lbs.	1450 RPM Input		1160 RPM Input		870 RPM Input	
Input HP	Output Torque in. lbs.		Motor Adapter	NEMA C-Frame Size <sup>4)</sup>	Input Shaft			Input HP	Output Torque in. lbs.	Input HP	Output Torque in. lbs.	Input HP	Output Torque in. lbs.
<b>730 RPM Output (Approximate)</b>													
								<b>600 RPM</b>		<b>485 RPM</b>		<b>360 RPM</b>	
7.23*	605	C102_0024	MR160/050	56C	AW160/012	2.394	247	6.38	644	5.50	694	4.54	764
7.23*	605	C102_0024	MR160/140	143/145TC	AW160/012	2.394	247	6.38	644	5.50	694	4.54	764
7.23*	605	C102_0024	MR200/180	182/184/TC	AW200/014	2.394	247	6.38	644	5.50	694	4.54	764
<b>710 RPM Output (Approximate)</b>													
								<b>580 RPM</b>		<b>470 RPM</b>		<b>350 RPM</b>	
9.84*	851	C202_0025	MR160/050	56C	AW160/012	2.475	351	8.15	851	6.52	851	4.89	851
9.84*	851	C202_0025	MR160/140	143/145TC	AW160/012	2.475	351	8.15	851	6.52	851	4.89	851
9.84	863	C302_0025	MR160/050	56C	AW160/012	2.510	523	8.15	863	6.52	863	4.89	863
9.84	863	C302_0025	MR160/140	143/145TC	AW160/012	2.510	523	8.15	863	6.52	863	4.89	863
10.80*	934	C202_0025	MR200/180	182/184/TC	AW200/014	2.475	351	9.53	995	8.18	1,068	6.14	1,068
17.52*	1,537	C302_0025	MR200/180	182/184/TC	AW200/014	2.510	523	15.46	1,636	13.32	1,762	10.99	1,940
17.52*	1,537	C302_0025	MR250/180	182/184/TC	AW250/102	2.510	523	15.46	1,636	13.32	1,762	10.99	1,940
23.36*	2,005	C402_0025	MR200/180	182/184/TC	AW200/014	2.456	893	19.36	2,005	15.48	2,005	11.61	2,005
23.36*	2,000	C502_0025	MR200/180	182/184/TC	AW200/014	2.450	1,095	19.36	2,000	15.48	2,000	11.61	2,000
25.86*	2,219	C402_0025	MR250/180	182/184/TC	AW250/102	2.456	893	22.81	2,362	19.66	2,545	16.23	2,801
35.39*	3,030	C502_0025	MR250/180	182/184/TC	AW250/102	2.450	1,095	29.32	3,030	23.46	3,030	17.59	3,030
40.14*	3,436	C502_0025	MR300/250	254/256TC	AW300/110	2.450	1,095	35.41	3,659	30.52	3,941	25.19	4,338
<b>680 RPM Output (Approximate)</b>													
								<b>550 RPM</b>		<b>450 RPM</b>		<b>335 RPM</b>	
6.88*	620	C102_0026	MR160/050	56C	AW160/012	2.582	252	6.07	661	5.23	712	4.32	783
6.88*	620	C102_0026	MR160/140	143/145TC	AW160/012	2.582	252	6.07	661	5.23	712	4.32	783
6.88*	620	C102_0026	MR200/180	182/184/TC	AW200/014	2.582	252	6.07	661	5.23	712	4.32	783
<b>650 RPM Output (Approximate)</b>													
								<b>530 RPM</b>		<b>430 RPM</b>		<b>320 RPM</b>	
9.84*	925	C202_0027	MR160/050	56C	AW160/012	2.690	358	8.15	925	6.52	925	4.89	925
9.84*	925	C202_0027	MR160/140	143/145TC	AW160/012	2.690	358	8.15	925	6.52	925	4.89	925
9.84	930	C302_0027	MR160/050	56C	AW160/012	2.705	533	8.15	930	6.52	930	4.89	930
9.84	930	C302_0027	MR160/140	143/145TC	AW160/012	2.705	533	8.15	930	6.52	930	4.89	930
10.22*	961	C202_0027	MR200/180	182/184/TC	AW200/014	2.690	358	9.02	1,023	7.77	1,102	6.14	1,160
16.67*	1,575	C302_0027	MR200/180	182/184/TC	AW200/014	2.705	533	14.70	1,677	12.67	1,807	10.46	1,989
16.67*	1,575	C302_0027	MR250/180	182/184/TC	AW250/102	2.705	533	14.70	1,677	12.67	1,807	10.46	1,989
<b>630 RPM Output (Approximate)</b>													
								<b>515 RPM</b>		<b>415 RPM</b>		<b>315 RPM</b>	
2.50	242	C002_0028	MR140/050	56C	AW140/010	2.769	180	2.07	242	1.66	242	1.24	242
3.28*	318	C002_0028	MR160/050	56C	AW160/012	2.769	180	2.90	338	2.50	364	2.06	401
3.28*	318	C002_0028	MR160/140	143/145TC	AW160/012	2.769	180	2.90	338	2.50	364	2.06	401
23.36*	2,275	C502_0028	MR200/180	182/184/TC	AW200/014	2.787	1,131	19.36	2,275	15.48	2,275	11.61	2,275
23.36*	2,262	C402_0028	MR200/180	182/184/TC	AW200/014	2.771	921	19.36	2,262	15.48	2,262	11.61	2,262
23.86*	2,310	C402_0028	MR250/180	182/184/TC	AW250/102	2.771	921	21.05	2,459	18.14	2,649	14.97	2,916
35.39*	3,447	C502_0028	MR250/180	182/184/TC	AW250/102	2.787	1,131	29.32	3,447	23.46	3,447	17.59	3,447
36.84*	3,587	C502_0028	MR300/250	254/256TC	AW300/110	2.787	1,131	32.50	3,819	28.00	4,114	23.12	4,528

## Part No. Explanation

**C 3 0 2 N 0620 AW 140 /012**

Unit No.  
Concentric Helical

Generation No.  
No. of Gear Reductions

Housing Style  
Ratio (0620 = 62.0:1)

Input Shaft  
Flange No.

Shaft Dia. (1/16 in.; example- 012=12/16 or 3/4)

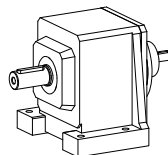

**C 3 0 2 N 0620 MR 160 /140**

Unit No.  
Concentric Helical

Generation No.  
No. of Reductions

Housing Style  
Ratio (0620 = 62.0:1)

Motor Adapter  
Flange No.

Motor Frame Size (140=143/145TC)

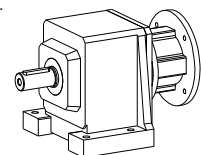

**Mounting position must be specified when ordering.**

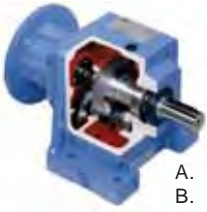

# "C" Series – Concentric Helical MGS Reducer – Selection Data



### Selection Procedure:

- Under the Input RPM heading, find **Approximate Output RPM** nearest the requirement.
- In the **Input HP** column locate the rating that is greater than or equal to the required HP. (If selection is based on Torque instead of HP, find an **Output Torque** that is equal to or greater than required.)
- When HP or Torque rating is located, read across that row to select the **Base Module**, **Input Option** and **Overhung Loads**.
- If exact **Output RPM** is required, divide the **Input RPM** by the **Exact Ratio**.

1750 RPM Input		Base Module <sup>1)</sup>	Input Options <sup>2)</sup>			Exact Ratio	Overhung Load Output Shaft <sup>3)</sup> lbs.	1450 RPM Input		1160 RPM Input		870 RPM Input	
Input HP	Output Torque in. lbs.		Motor Adapter	NEMA C-Frame Size <sup>4)</sup>	Input Shaft			Input HP	Output Torque in. lbs.	Input HP	Output Torque in. lbs.	Input HP	Output Torque in. lbs.
<b>565 RPM Output (Approximate)</b>													
2.46	264	C002_0031	MR140/050	56C	AW140/010	3.067	185	2.04	264	1.63	264	1.22	264
2.61	282	C102_0031	MR140/050	56C	AW140/010	3.091	263	2.16	282	1.73	282	1.30	282
3.07*	329	C002_0031	MR160/050	56C	AW160/012	3.067	185	2.70	350	2.33	377	1.92	415
3.07*	329	C002_0031	MR160/140	143/145TC	AW160/012	3.067	185	2.70	350	2.33	377	1.92	415
6.10*	659	C102_0031	MR160/050	56C	AW160/012	3.091	263	5.38	701	4.64	756	3.83	832
6.10*	659	C102_0031	MR160/140	143/145TC	AW160/012	3.091	263	5.38	701	4.64	756	3.83	832
6.10*	659	C102_0031	MR200/180	182/184/TC	AW200/014	3.091	263	5.38	701	4.64	756	3.83	832
9.29*	1,007	C202_0031	MR160/050	56C	AW160/012	3.103	371	8.15	1,066	6.52	1,066	4.89	1,066
9.29*	1,007	C202_0031	MR160/140	143/145TC	AW160/012	3.103	371	8.15	1,066	6.52	1,066	4.89	1,066
9.29*	1,007	C202_0031	MR200/180	182/184/TC	AW200/014	3.103	371	8.20	1,073	7.06	1,155	5.83	1,272
9.84	1,069	C302_0031	MR160/050	56C	AW160/012	3.110	552	8.15	1,069	6.52	1,069	4.89	1,069
9.84	1,069	C302_0031	MR160/140	143/145TC	AW160/012	3.110	552	8.15	1,069	6.52	1,069	4.89	1,069
15.19*	1,650	C302_0031	MR200/180	182/184/TC	AW200/014	3.110	552	13.40	1,757	11.55	1,893	9.53	2,083
15.19*	1,650	C302_0031	MR250/180	182/184/TC	AW250/102	3.110	552	13.40	1,757	11.55	1,893	9.53	2,083
22.14*	2,398	C402_0031	MR200/180	182/184/TC	AW200/014	3.099	947	19.36	2,530	15.48	2,530	11.61	2,530
22.14*	2,398	C402_0031	MR250/210	213/215/TC	AW250/102	3.099	947	19.53	2,553	16.83	2,750	13.90	3,027
23.36*	2,512	C502_0031	MR200/180	182/184/TC	AW200/014	3.077	1,159	19.36	2,512	15.48	2,512	11.61	2,512
34.24*	3,682	C502_0031	MR250/180	182/184/TC	AW250/102	3.077	1,159	28.37	3,682	22.70	3,682	17.02	3,682
34.24*	3,682	C502_0031	MR300/250	254/256TC	AW300/110	3.077	1,159	28.37	3,682	22.70	3,682	17.02	3,682
<b>525 RPM Output (Approximate)</b>													
2.46	285	C002_0033	MR140/050	56C	AW140/010	3.318	189	2.04	285	1.63	285	1.22	285
2.61	304	C102_0033	MR140/050	56C	AW140/010	3.334	268	2.16	304	1.73	304	1.30	304
2.91	337	C002_0033	MR160/050	56C	AW160/012	3.318	189	2.57	359	2.21	387	1.83	426
2.91	337	C002_0033	MR160/140	143/145TC	AW160/012	3.318	189	2.57	359	2.21	387	1.83	426
5.80*	676	C102_0033	MR160/050	56C	AW160/012	3.334	268	5.12	719	4.41	775	3.64	853
5.80*	676	C102_0033	MR160/140	143/145TC	AW160/012	3.334	268	5.12	719	4.41	775	3.64	853
5.80*	676	C102_0033	MR200/180	182/184/TC	AW200/014	3.334	268	5.12	719	4.41	775	3.64	853
<b>520 RPM Output (Approximate)</b>													
8.79*	1,036	C202_0034	MR160/050	56C	AW160/012	3.373	379	7.75	1,103	6.52	1,159	4.89	1,159
8.79*	1,036	C202_0034	MR160/140	143/145TC	AW160/012	3.373	379	7.75	1,103	6.52	1,159	4.89	1,159
8.79*	1,036	C202_0034	MR200/180	182/184/TC	AW200/014	3.373	379	7.75	1,103	6.68	1,188	5.52	1,308
9.84	1,152	C302_0034	MR160/050	56C	AW160/012	3.352	562	8.15	1,152	6.52	1,152	4.89	1,152
9.84	1,152	C302_0034	MR160/140	143/145TC	AW160/012	3.352	562	8.15	1,152	6.52	1,152	4.89	1,152
14.45*	1,692	C302_0034	MR200/180	182/184/TC	AW200/014	3.352	562	12.74	1,802	10.98	1,941	9.07	2,136
14.45*	1,692	C302_0034	MR250/180	182/184/TC	AW250/102	3.352	562	12.74	1,802	10.98	1,941	9.07	2,136

\* For thermal HP capacity, see rating below.

Base Module	C0	C1	C2	C3	C4	C5	C6	C7	C8	C9
Thermal Capacity	2.95	5.36	7.38	12.34	14.75	20.12	29.50	40.23	53.64	67.05

NEMA Frame Size  
TEFC 1750 RPM

C-Frame	Motor HP
56C	1/3 - 1 1/2
143/145TC	1, 1 1/2, 2
182/184TC	3, 5
213/215TC	7 1/2, 10
254/256TC	15, 20
284/286TC	25, 30
324/326TC	40, 50
364/365TC	60, 75

### Housing Styles

N – Foot Mounted    F – Round Flange    Q – Square Flange    G – Tapped Holes

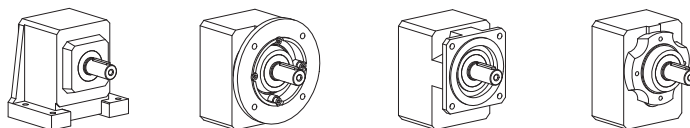

Housing Style Q is available on special order.



# "C" Series – Concentric Helical MGS Reducer – Selection Data



- NOTE:** 1) Complete Base Module Part Number by adding Housing Style. Example: C302N0620.  
 2) Select Input Option and add to completed Part Number. See example below.  
 3) Overhung Load is measured at the center of the shaft extension. Hollow output units are not intended to support overhung loads. If a load rating is required, use 50% of the published overhung load.  
 4) Other frame sizes may also be available. See dimension pages.

1750 RPM Input		Base Module <sup>1)</sup>	Input Options <sup>2)</sup>			Exact Ratio	Overhung Load Output Shaft <sup>3)</sup> lbs.	1450 RPM Input		1160 RPM Input		870 RPM Input	
Input HP	Output Torque in. lbs.		Motor Adapter	NEMA C-Frame Size <sup>4)</sup>	Input Shaft			Input HP	Output Torque in. lbs.	Input HP	Output Torque in. lbs.	Input HP	Output Torque in. lbs.
<b>500 RPM Output (Approximate)</b>													
								<b>410 RPM</b>	<b>330 RPM</b>	<b>250 RPM</b>			
20.43*	2,496	C402_0035	MR200/180	182/184/TC	AW200/014	3.497	976	18.02	2,658	15.48	2,854	11.61	2,854
20.43*	2,496	C402_0035	MR250/180	182/184/TC	AW250/102	3.497	976	18.02	2,658	15.53	2,863	12.82	3,151
23.36*	2,858	C502_0035	MR200/180	182/184/TC	AW200/014	3.501	1,198	19.36	2,858	15.48	2,858	11.61	2,858
31.64*	3,871	C502_0035	MR250/210	213/215/TC	AW250/102	3.501	1,198	27.91	4,121	22.70	4,189	17.02	4,189
31.64*	3,871	C502_0035	MR300/250	254/256TC	AW300/110	3.501	1,198	27.91	4,121	22.70	4,189	17.02	4,189
<b>450 RPM Output (Approximate)</b>													
								<b>370 RPM</b>	<b>300 RPM</b>	<b>225 RPM</b>			
2.37	318	C002_0038	MR140/050	56C	AW140/010	3.835	196	1.97	318	1.57	318	1.18	318
2.52	342	C102_0039	MR140/050	56C	AW140/010	3.883	279	2.09	342	1.67	342	1.25	342
2.64	354	C002_0038	MR160/050	56C	AW160/012	3.835	196	2.33	377	2.01	406	1.66	447
2.64	354	C002_0038	MR160/140	143/145TC	AW160/012	3.835	196	2.33	377	2.01	406	1.66	447
5.24	711	C102_0039	MR160/050	56C	AW160/012	3.883	279	4.62	757	3.98	815	3.29	897
5.24	711	C102_0039	MR160/140	143/145TC	AW160/012	3.883	279	4.62	757	3.98	815	3.29	897
5.24	711	C102_0039	MR200/180	182/184/TC	AW200/014	3.883	279	4.62	757	3.98	815	3.29	897
7.99*	1,086	C202_0039	MR160/050	56C	AW160/012	3.888	393	7.05	1,156	6.08	1,246	4.89	1,336
7.99*	1,086	C202_0039	MR160/140	143/145TC	AW160/012	3.888	393	7.05	1,156	6.08	1,246	4.89	1,336
7.99*	1,086	C202_0039	MR200/180	182/184/TC	AW200/014	3.888	393	7.05	1,156	6.08	1,246	5.02	1,371
9.84	1,333	C302_0039	MR160/050	56C	AW160/012	3.878	583	8.15	1,333	6.52	1,333	4.89	1,333
9.84	1,333	C302_0039	MR160/140	143/145TC	AW160/012	3.878	583	8.15	1,333	6.52	1,333	4.89	1,333
9.84	1,338	C402_0039	MR160/050	56C	AW160/012	3.894	1,002	8.15	1,338	6.52	1,338	4.89	1,338
9.84	1,338	C402_0039	MR160/140	143/145TC	AW160/012	3.894	1,002	8.15	1,338	6.52	1,338	4.89	1,338
13.11*	1,776	C302_0039	MR200/180	182/184/TC	AW200/014	3.878	583	11.56	1,891	9.97	2,037	8.23	2,242
13.11*	1,776	C302_0039	MR250/180	182/184/TC	AW250/102	3.878	583	11.56	1,891	9.97	2,037	8.23	2,242
19.02*	2,587	C402_0039	MR200/180	182/184/TC	AW200/014	3.894	1,002	16.78	2,755	14.46	2,967	11.61	3,179
19.02*	2,587	C402_0039	MR250/180	182/184/TC	AW250/102	3.894	1,002	16.78	2,755	14.46	2,967	11.93	3,266
23.36*	3,156	C502_0039	MR200/180	182/184/TC	AW200/014	3.867	1,228	19.36	3,156	15.48	3,156	11.61	3,156
29.61*	4,001	C502_0039	MR250/180	182/184/TC	AW250/102	3.867	1,228	26.12	4,260	21.90	4,464	16.43	4,464
29.61*	4,001	C502_0039	MR300/250	254/256TC	AW300/110	3.867	1,228	26.12	4,260	21.90	4,464	16.43	4,464
<b>420 RPM Output (Approximate) Continued Next Page</b>													
								<b>345 RPM</b>	<b>280 RPM</b>	<b>210 RPM</b>			
2.37	344	C002_0041	MR140/050	56C	AW140/010	4.149	199	1.97	344	1.57	344	1.18	344
2.51	363	C002_0041	MR160/050	56C	AW160/012	4.149	199	2.21	387	1.91	417	1.57	459
2.51	363	C002_0041	MR160/140	143/145TC	AW160/012	4.149	199	2.21	387	1.91	417	1.57	459
2.52	369	C102_0042	MR140/050	56C	AW140/010	4.189	284	2.09	369	1.67	369	1.25	369
4.98	729	C102_0042	MR160/050	56C	AW160/012	4.189	284	4.39	776	3.79	836	3.13	920
4.98	729	C102_0042	MR160/140	143/145TC	AW160/012	4.189	284	4.39	776	3.79	836	3.13	920
4.98	729	C102_0042	MR200/180	182/184/TC	AW200/014	4.189	284	4.39	776	3.79	836	3.13	920
7.56	1,117	C202_0042	MR160/050	56C	AW160/012	4.226	401	6.67	1,189	5.75	1,281	4.75	1,410
7.56	1,117	C202_0042	MR160/140	143/145TC	AW160/012	4.226	401	6.67	1,189	5.75	1,281	4.75	1,410
7.56	1,117	C202_0042	MR200/180	182/184/TC	AW200/014	4.226	401	6.67	1,189	5.75	1,281	4.75	1,410

### Part No. Explanation

**C 3 0 2 N 0620 AW 140 /012**

Unit No.  
 Concentric Helical  
 Generation No.  
 No. of Gear Reductions  
 Housing Style  
 Ratio (0620 = 62.0:1)  
 Input Shaft  
 Flange No.  
 Shaft Dia. (1/16 in.; example- 012=12/16 or 3/4)

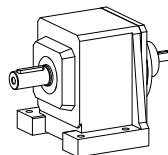

**C 3 0 2 N 0620 MR 160 /140**

Unit No.  
 Concentric Helical  
 Generation No.  
 No. of Reductions  
 Housing Style  
 Ratio (0620 = 62.0:1)  
 Motor Adapter  
 Flange No.  
 Motor Frame Size (140=143/145TC)

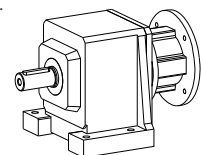

**Mounting position must be specified when ordering.**



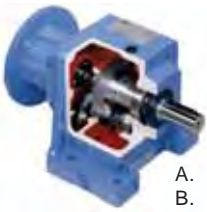

# "C" Series – Concentric Helical MGS Reducer – Selection Data



## Selection Procedure:

- Under the Input RPM heading, find **Approximate Output RPM** nearest the requirement.
- In the **Input HP** column locate the rating that is greater than or equal to the required HP.  
(If selection is based on Torque instead of HP, find an **Output Torque** that is equal to or greater than required.)
- When HP or Torque rating is located, read across that row to select the **Base Module**, **Input Option** and **Overhung Loads**.
- If exact **Output RPM** is required, divide the **Input RPM** by the **Exact Ratio**.

1750 RPM Input		Base Module <sup>1)</sup>	Input Options <sup>2)</sup>			Exact Ratio	Overhung Load Output Shaft <sup>3)</sup> lbs.	1450 RPM Input		1160 RPM Input		870 RPM Input	
Input HP	Output Torque in. lbs.		Motor Adapter	NEMA C-Frame Size <sup>4)</sup>	Input Shaft			Input HP	Output Torque in. lbs.	Input HP	Output Torque in. lbs.	Input HP	Output Torque in. lbs.
<b>420 RPM Output (Approximate) Continued</b>													
9.84	1,436	C302_0042	MR160/050	56C	AW160/012	4.179	594	8.15	1,436	6.52	1,436	4.89	1,436
9.84	1,436	C302_0042	MR160/140	143/145TC	AW160/012	4.179	594	8.15	1,436	6.52	1,436	4.89	1,436
12.47*	1,821	C302_0042	MR200/180	182/184TC	AW200/014	4.179	594	11.00	1,939	9.48	2,089	7.83	2,299
12.47*	1,821	C302_0042	MR250/210	213/215TC	AW250/102	4.179	594	11.00	1,939	9.48	2,089	7.83	2,299
23.36	3,415	C612_0042	MR200/180	182/184TC	AW200/014	4.184	1,683	19.36	3,415	15.48	3,415	11.61	3,415
37.73*	5,517	C612_0042	MR250/180	182/184TC	AW250/102	4.184	1,683	31.27	5,517	25.01	5,517	18.76	5,517
52.15*	7,625	C612_0042	MR300/250	254/256TC	AW300/110	4.184	1,683	46.01	8,118	39.65	8,745	32.73	9,625
79.57*	11,747	C812_0042	MR300/250	254/256TC	AW300/110	4.225	3,164	65.93	11,747	52.74	11,747	39.56	11,747
122.95*	18,151	C812_0042	MR350/320	324/326TC	AW350/202	4.225	3,164	101.87	18,151	81.50	18,151	61.12	18,151
122.95*	17,816	C912_0041	MR350/320	324/326TC	AW350/202	4.147	3,884	101.87	17,816	81.50	17,816	61.12	17,816
<b>410 RPM Output (Approximate)</b>													
23.36	3,476	C712_0043	MR200/180	182/184TC	AW200/014	4.259	2,325	19.36	3,476	15.48	3,476	11.61	3,476
39.62	5,895	C712_0043	MR250/210	213/215TC	AW250/102	4.259	2,325	32.82	5,895	26.26	5,895	19.69	5,895
75.70*	11,266	C712_0043	MR300/280	284/286TC	AW300/110	4.259	2,325	62.72	11,266	50.18	11,266	37.63	11,266
<b>400 RPM Output (Approximate)</b>													
9.84	1,510	C402_0044	MR160/050	56C	AW160/012	4.394	1,033	8.15	1,510	6.52	1,510	4.89	1,510
9.84	1,510	C402_0044	MR160/140	143/145TC	AW160/012	4.394	1,033	8.15	1,510	6.52	1,510	4.89	1,510
17.54*	2,694	C402_0044	MR200/180	182/184TC	AW200/014	4.394	1,033	15.48	2,868	13.34	3,089	11.01	3,400
17.54*	2,694	C402_0044	MR250/210	213/215TC	AW250/102	4.394	1,033	15.48	2,868	13.34	3,089	11.01	3,400
23.36*	3,591	C502_0044	MR200/180	182/184TC	AW200/014	4.399	1,268	19.36	3,591	15.48	3,591	11.61	3,591
27.17*	4,177	C502_0044	MR250/210	213/215TC	AW250/102	4.399	1,268	23.97	4,447	20.66	4,790	16.43	5,079
27.17*	4,177	C502_0044	MR300/280	284/286TC	AW300/110	4.399	1,268	23.97	4,447	20.66	4,790	16.43	5,079
<b>375 RPM Output (Approximate) Continued Next Page</b>													
2.30	376	C002_0047	MR140/050	56C	AW140/010	4.680	206	1.90	376	1.52	376	1.14	376
2.31	378	C002_0047	MR160/050	56C	AW160/012	4.680	206	2.04	403	1.76	434	1.45	477
2.31	378	C002_0047	MR160/140	143/145TC	AW160/012	4.680	206	2.04	403	1.76	434	1.45	477
2.44	397	C102_0047	MR140/050	56C	AW140/010	4.658	292	2.02	397	1.62	397	1.21	397
4.64	755	C102_0047	MR160/050	56C	AW160/012	4.658	292	4.09	804	3.53	866	2.91	953
4.64	755	C102_0047	MR160/140	143/145TC	AW160/012	4.658	292	4.09	804	3.53	866	2.91	953
4.64	755	C102_0047	MR200/180	182/184TC	AW200/014	4.658	292	4.09	804	3.53	866	2.91	953
7.08	1,154	C202_0047	MR160/050	56C	AW160/012	4.667	411	6.24	1,229	5.38	1,324	4.44	1,457
7.08	1,154	C202_0047	MR160/140	143/145TC	AW160/012	4.667	411	6.24	1,229	5.38	1,324	4.44	1,457
7.08	1,154	C202_0047	MR200/180	182/184TC	AW200/014	4.667	411	6.24	1,229	5.38	1,324	4.44	1,457
9.84	1,591	C502_0046	MR160/050	56C	AW160/012	4.629	1,284	8.15	1,591	6.52	1,591	4.89	1,591
9.84	1,591	C502_0046	MR160/140	143/145TC	AW160/012	4.629	1,284	8.15	1,591	6.52	1,591	4.89	1,591
9.84	1,607	C302_0047	MR160/050	56C	AW160/012	4.675	611	8.15	1,607	6.52	1,607	4.89	1,607
9.84	1,607	C302_0047	MR160/140	143/145TC	AW160/012	4.675	611	8.15	1,607	6.52	1,607	4.89	1,607

\* For thermal HP capacity, see rating below.

Base Module	C0	C1	C2	C3	C4	C5	C6	C7	C8	C9
Thermal Capacity	2.95	5.36	7.38	12.34	14.75	20.12	29.50	40.23	53.64	67.05

## NEMA Frame Size TEFC 1750 RPM

C-Frame	Motor HP
56C	1/3 - 1 1/2
143/145TC	1, 1 1/2, 2
182/184TC	3, 5
213/215TC	7 1/2, 10
254/256TC	15, 20
284/286TC	25, 30
324/326TC	40, 50
364/365TC	60, 75

## Housing Styles

N – Foot Mounted    F – Round Flange    Q – Square Flange    G – Tapped Holes

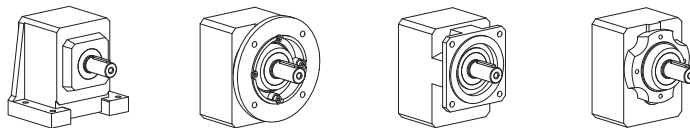

Housing Style Q is available on special order.





# "C" Series – Concentric Helical MGS Reducer – Selection Data



- NOTE:** 1) Complete Base Module Part Number by adding Housing Style. Example: C302N0560.  
 2) Select Input Option and add to completed Part Number. See example below.  
 3) Overhung Load is measured at the center of the shaft extension. Hollow output units are not intended to support overhung loads. If a load rating is required, use 50% of the published overhung load.  
 4) Other frame sizes may also be available. See dimension pages.

1750 RPM Input		Base Module <sup>1)</sup>	Input Options <sup>2)</sup>			Exact Ratio	Overhung Load Output Shaft <sup>3)</sup> lbs.	1450 RPM Input		1160 RPM Input		870 RPM Input	
Input HP	Output Torque in. lbs.		Motor Adapter	NEMA C-Frame Size <sup>4)</sup>	Input Shaft			Input HP	Output Torque in. lbs.	Input HP	Output Torque in. lbs.	Input HP	Output Torque in. lbs.
<b>375 RPM Output (Approximate) Continued</b>													
								<b>305 RPM</b>	<b>250 RPM</b>	<b>185 RPM</b>			
9.84	1,609	C402_0047	MR160/050	56C	AW160/012	4.682	1,050	8.15	1,609	6.52	1,609	4.89	1,609
9.84	1,609	C402_0047	MR160/140	143/145TC	AW160/012	4.682	1,050	8.15	1,609	6.52	1,609	4.89	1,609
11.57	1,891	C302_0047	MR200/180	182/184/TC	AW200/014	4.675	611	10.21	2,013	8.80	2,168	7.26	2,387
11.57	1,891	C302_0047	MR250/180	182/184/TC	AW250/102	4.675	611	10.21	2,013	8.80	2,168	7.26	2,387
16.82*	2,751	C402_0047	MR200/180	182/184/TC	AW200/014	4.682	1,050	14.84	2,929	12.79	3,155	10.55	3,473
16.82*	2,751	C402_0047	MR250/180	182/184/TC	AW250/102	4.682	1,050	14.84	2,929	12.79	3,155	10.55	3,473
22.97*	3,715	C502_0046	MR200/180	182/184/TC	AW200/014	4.629	1,284	19.36	3,778	15.48	3,778	11.61	3,778
26.27*	4,248	C502_0046	MR250/180	182/184/TC	AW250/102	4.629	1,284	23.17	4,523	19.97	4,872	15.88	5,166
26.27*	4,248	C502_0046	MR300/280	284/286TC	AW300/110	4.629	1,284	23.17	4,523	19.97	4,872	15.88	5,166
<b>345 RPM Output (Approximate)</b>													
								<b>280 RPM</b>	<b>230 RPM</b>	<b>170 RPM</b>			
2.19	388	C002_0051	MR140/050	56C	AW140/010	5.063	210	1.90	406	1.52	406	1.14	406
2.19	388	C002_0051	MR160/050	56C	AW160/012	5.063	210	1.94	413	1.67	445	1.38	490
2.19	388	C002_0051	MR160/140	143/145TC	AW160/012	5.063	210	1.94	413	1.67	445	1.38	490
2.44	428	C102_0050	MR160/050	56TC	AW140/010	5.025	297	2.02	428	1.62	428	1.21	428
2.44	428	C102_0050	MR160/140	143/145TC	AW140/010	5.025	297	2.02	428	1.62	428	1.21	428
4.41	775	C102_0050	MR160/050	56C	AW160/012	5.025	297	3.89	825	3.35	888	2.77	978
4.41	775	C102_0050	MR160/140	143/145TC	AW160/012	5.025	297	3.89	825	3.35	888	2.77	978
4.41	775	C102_0050	MR200/180	182/184/TC	AW200/014	5.025	297	3.89	825	3.35	888	2.77	978
6.70	1,187	C202_0051	MR160/050	56C	AW160/012	5.072	420	5.91	1,264	5.09	1,361	4.20	1,498
6.70	1,187	C202_0051	MR160/140	143/145TC	AW160/012	5.072	420	5.91	1,264	5.09	1,361	4.20	1,498
6.70	1,187	C202_0051	MR200/180	182/184/TC	AW200/014	5.072	420	5.91	1,264	5.09	1,361	4.20	1,498
9.84	1,731	C302_0050	MR160/050	56C	AW160/012	5.037	623	8.15	1,731	6.52	1,731	4.89	1,731
9.84	1,731	C302_0050	MR160/140	143/145TC	AW160/012	5.037	623	8.15	1,731	6.52	1,731	4.89	1,731
11.01	1,938	C302_0050	MR200/180	182/184/TC	AW200/014	5.037	623	9.71	2,064	8.37	2,223	6.91	2,447
11.01	1,938	C302_0050	MR250/180	182/184/TC	AW250/102	5.037	623	9.71	2,064	8.37	2,223	6.91	2,447
23.36	4,149	C612_0051	MR200/180	182/184/TC	AW200/014	5.083	1,767	19.36	4,149	15.48	4,149	11.61	4,149
36.77*	6,531	C612_0051	MR250/180	182/184/TC	AW250/102	5.083	1,767	30.47	6,531	24.37	6,531	18.28	6,531
45.81*	8,136	C612_0051	MR300/180	182/184/TC	AW300/110	5.083	1,767	40.41	8,662	34.82	9,331	28.75	10,270
<b>330 RPM Output (Approximate) Continued Next Page</b>													
								<b>270 RPM</b>	<b>220 RPM</b>	<b>165 RPM</b>			
9.84	1,810	C502_0053	MR160/050	56C	AW160/012	5.265	1,326	8.15	1,810	6.52	1,810	4.89	1,810
9.84	1,810	C502_0053	MR160/140	143/145TC	AW160/012	5.265	1,326	8.15	1,810	6.52	1,810	4.89	1,810
9.84	1,816	C402_0053	MR160/050	56C	AW160/012	5.284	1,082	8.15	1,816	6.52	1,816	4.89	1,816
9.84	1,816	C402_0053	MR160/140	143/145TC	AW160/012	5.284	1,082	8.15	1,816	6.52	1,816	4.89	1,816
15.51*	2,865	C402_0053	MR200/180	182/184/TC	AW200/014	5.284	1,082	13.69	3,050	11.79	3,285	9.74	3,616
15.51*	2,865	C402_0053	MR250/210	213/215/TC	AW250/102	5.284	1,082	13.69	3,050	11.79	3,285	9.74	3,616
22.97*	4,226	C502_0053	MR200/180	182/184/TC	AW200/014	5.265	1,326	19.36	4,298	15.48	4,298	11.61	4,298
23.36	4,335	C712_0053	MR200/180	182/184/TC	AW200/014	5.311	2,457	19.36	4,335	15.48	4,335	11.61	4,335
24.11*	4,435	C502_0053	MR250/180	182/184/TC	AW250/102	5.265	1,326	21.27	4,722	18.33	5,086	15.13	5,598

### Part No. Explanation

**C 3 0 2 N 0620 AW 140 /012**

Unit No.  
 Concentric Helical  
 Generation No.  
 No. of Gear Reductions  
 Housing Style  
 Ratio (0620 = 62.0:1)  
 Input Shaft  
 Flange No.  
 Shaft Dia. (1/16 in.; example- 012=12/16 or 3/4)

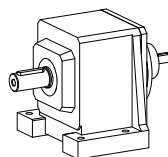

**C 3 0 2 N 0620 MR 160 /140**

Unit No.  
 Concentric Helical  
 Generation No.  
 No. of Reductions  
 Housing Style  
 Ratio (0620 = 62.0:1)  
 Motor Adapter  
 Flange No.  
 Motor Frame Size (140=143/145TC)

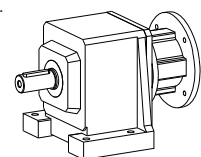

**Mounting position must be specified when ordering.**

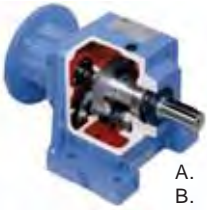

# "C" Series – Concentric Helical MGS Reducer – Selection Data



### Selection Procedure:

- Under the Input RPM heading, find **Approximate Output RPM** nearest the requirement.
- In the **Input HP** column locate the rating that is greater than or equal to the required HP.  
(If selection is based on Torque instead of HP, find an **Output Torque** that is equal to or greater than required.)
- When HP or Torque rating is located, read across that row to select the **Base Module**, **Input Option** and **Overhung Loads**.
- If exact **Output RPM** is required, divide the **Input RPM** by the **Exact Ratio**.

1750 RPM Input		Base Module <sup>1)</sup>	Input Options <sup>2)</sup>			Exact Ratio	Overhung Load Output Shaft <sup>3)</sup> lbs.	1450 RPM Input		1160 RPM Input		870 RPM Input	
Input HP	Output Torque in. lbs.		Motor Adapter	NEMA C-Frame Size <sup>4)</sup>	Input Shaft			Input HP	Output Torque in. lbs.	Input HP	Output Torque in. lbs.	Input HP	Output Torque in. lbs.
<b>330 RPM Output (Approximate) Continued</b>													
<b>270 RPM      220 RPM      165 RPM</b>													
24.11*	4,435	C502_0053	MR300/210	213/215/TC	AW300/110	5.265	1,326	21.27	4,722	18.33	5,086	15.13	5,598
38.46	7,137	C712_0053	MR250/180	182/184/TC	AW250/102	5.311	2,457	31.87	7,137	25.49	7,137	19.12	7,137
73.49*	13,638	C712_0053	MR300/250	254/256TC	AW300/110	5.311	2,457	60.89	13,638	48.71	13,638	36.53	13,638
122.95*	22,396	C912_0052	MR350/320	324/326TC	AW350/202	5.213	4,113	101.87	22,396	81.50	22,396	61.12	22,396
<b>325 RPM Output (Approximate)</b>													
<b>265 RPM      215 RPM      160 RPM</b>													
77.01*	14,495	C812_0054	MR300/250	254/256TC	AW300/110	5.387	3,362	63.81	14,495	51.05	14,495	38.28	14,495
118.49*	22,304	C812_0054	MR350/360	364/365TC	AW350/202	5.387	3,362	101.87	23,143	81.50	23,143	61.12	23,143
<b>300 RPM Output (Approximate)</b>													
<b>245 RPM      200 RPM      150 RPM</b>													
2.00	407	C002_0058	MR140/050	56C	AW140/010	5.824	217	1.76	433	1.46	450	1.10	450
2.00	407	C002_0058	MR160/050	56C	AW160/012	5.824	217	1.76	433	1.52	467	1.25	514
2.00	407	C002_0058	MR160/140	143/145TC	AW160/012	5.824	217	1.76	433	1.52	467	1.25	514
2.35	482	C102_0059	MR140/050	56C	AW140/010	5.875	309	1.94	482	1.56	482	1.17	482
2.42	490	C202_0058	MR140/050	56C	AW140/010	5.791	434	2.01	490	1.61	490	1.20	490
3.98	816	C102_0059	MR160/050	56C	AW160/012	5.875	309	3.51	869	3.02	936	2.49	1,030
3.98	816	C102_0059	MR160/140	143/145TC	AW160/012	5.875	309	3.51	869	3.02	936	2.49	1,030
3.98	816	C102_0059	MR200/180	182/184/TC	AW200/014	5.875	309	3.51	869	3.02	936	2.49	1,030
6.13	1,240	C202_0058	MR160/050	56C	AW160/012	5.791	434	5.41	1,321	4.66	1,423	3.85	1,566
6.13	1,240	C202_0058	MR160/140	143/145TC	AW160/012	5.791	434	5.41	1,321	4.66	1,423	3.85	1,566
6.13	1,240	C202_0058	MR200/180	182/184/TC	AW200/014	5.791	434	5.41	1,321	4.66	1,423	3.85	1,566
8.89	1,820	C302_0059	MR160/050	56C	AW160/012	5.859	647	7.84	1,938	6.52	2,014	4.89	2,014
8.89	1,820	C302_0059	MR160/140	143/145TC	AW160/012	5.859	647	7.84	1,938	6.52	2,014	4.89	2,014
9.84	2,011	C502_0059	MR160/050	56C	AW160/012	5.850	1,361	8.15	2,011	6.52	2,011	4.89	2,011
9.84	2,011	C502_0059	MR160/140	143/145TC	AW160/012	5.850	1,361	8.15	2,011	6.52	2,011	4.89	2,011
9.84	2,025	C402_0059	MR160/050	56C	AW160/012	5.891	1,112	8.15	2,025	6.52	2,025	4.89	2,025
9.84	2,025	C402_0059	MR160/140	143/145TC	AW160/012	5.891	1,112	8.15	2,025	6.52	2,025	4.89	2,025
9.96	2,038	C302_0059	MR200/180	182/184/TC	AW200/014	5.859	647	8.78	2,170	7.57	2,338	6.25	2,573
9.96	2,038	C302_0059	MR250/180	182/184/TC	AW250/102	5.859	647	8.78	2,170	7.57	2,338	6.25	2,573
14.43	2,970	C402_0059	MR200/180	182/184/TC	AW200/014	5.891	1,112	12.73	3,162	10.97	3,407	9.06	3,749
14.43	2,970	C402_0059	MR250/180	182/184/TC	AW250/102	5.891	1,112	12.73	3,162	10.97	3,407	9.06	3,749
19.88	4,064	C502_0059	MR200/180	182/184/TC	AW200/014	5.850	1,361	17.54	4,327	15.12	4,661	11.61	4,775
22.47*	4,593	C502_0059	MR250/180	182/184/TC	AW250/102	5.850	1,361	19.82	4,890	17.08	5,268	14.10	5,798
22.47*	4,593	C502_0059	MR300/250	254/256TC	AW300/110	5.850	1,361	19.82	4,890	17.08	5,268	14.10	5,798
<b>275 RPM Output (Approximate) Continued Next Page</b>													
<b>225 RPM      185 RPM      135 RPM</b>													
1.90	418	C002_0063	MR140/050	56C	AW140/010	6.300	221	1.67	445	1.44	479	1.10	486
1.90	418	C002_0063	MR160/050	56C	AW160/012	6.300	221	1.67	445	1.44	479	1.19	527
1.90	418	C002_0063	MR160/140	143/145TC	AW160/012	6.300	221	1.67	445	1.44	479	1.19	527
2.35	520	C102_0063	MR140/050	56C	AW140/010	6.338	315	1.94	520	1.56	520	1.17	520

\* For thermal HP capacity, see rating below.

Base Module	C0	C1	C2	C3	C4	C5	C6	C7	C8	C9
Thermal Capacity	2.95	5.36	7.38	12.34	14.75	20.12	29.50	40.23	53.64	67.05

NEMA Frame Size  
TEFC 1750 RPM

C-Frame	Motor HP
56C	1/3 - 1 1/2
143/145TC	1, 1 1/2, 2
182/184TC	3, 5
213/215TC	7 1/2, 10
254/256TC	15, 20
284/286TC	25, 30
324/326TC	40, 50
364/365TC	60, 75

### Housing Styles

N – Foot Mounted    F – Round Flange    Q – Square Flange    G – Tapped Holes

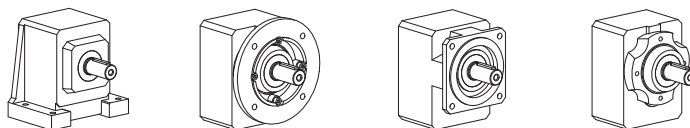

Housing Style Q is available on special order.



# "C" Series – Concentric Helical MGS Reducer – Selection Data



- NOTE:** 1) Complete Base Module Part Number by adding Housing Style. Example: C302N0560.  
 2) Select Input Option and add to completed Part Number. See example below.  
 3) Overhung Load is measured at the center of the shaft extension. Hollow output units are not intended to support overhung loads. If a load rating is required, use 50% of the published overhung load.  
 4) Other frame sizes may also be available. See dimension pages.

1750 RPM Input		Base Module <sup>1)</sup>	Input Options <sup>2)</sup>			Exact Ratio	Overhung Load Output Shaft <sup>3)</sup> lbs.	1450 RPM Input		1160 RPM Input		870 RPM Input	
Input HP	Output Torque in. lbs.		Motor Adapter	NEMA C-Frame Size <sup>4)</sup>	Input Shaft			Input HP	Output Torque in. lbs.	Input HP	Output Torque in. lbs.	Input HP	Output Torque in. lbs.
<b>275 RPM Output (Approximate) Continued</b>													
								<b>225 RPM</b>		<b>185 RPM</b>		<b>135 RPM</b>	
2.42	533	C202_0063	MR140/050	56C	AW140/010	6.295	443	2.01	533	1.61	533	1.20	533
3.78	837	C102_0063	MR160/050	56C	AW160/012	6.338	315	3.33	891	2.87	960	2.37	1,057
3.78	837	C102_0063	MR160/140	143/145TC	AW160/012	6.338	315	3.33	891	2.87	960	2.37	1,057
3.78	837	C102_0063	MR200/180	182/184/TC	AW200/014	6.338	315	3.33	891	2.87	960	2.37	1,057
5.80	1,275	C202_0063	MR160/050	56C	AW160/012	6.295	443	5.12	1,358	4.41	1,463	3.64	1,610
5.80	1,275	C202_0063	MR160/140	143/145TC	AW160/012	6.295	443	5.12	1,358	4.41	1,463	3.64	1,610
5.80	1,275	C202_0063	MR200/180	182/184/TC	AW200/014	6.295	443	5.12	1,358	4.41	1,463	3.64	1,610
8.89	1,962	C302_0063	MR160/050	56C	AW160/012	6.314	659	7.84	2,089	6.52	2,170	4.89	2,170
8.89	1,962	C302_0063	MR160/140	143/145TC	AW160/012	6.314	659	7.84	2,089	6.52	2,170	4.89	2,170
9.47	2,090	C302_0063	MR200/180	182/184/TC	AW200/014	6.314	659	8.36	2,225	7.20	2,397	5.94	2,638
9.47	2,090	C302_0063	MR250/180	182/184/TC	AW250/102	6.314	659	8.36	2,225	7.20	2,397	5.94	2,638
<b>260 RPM Output (Approximate)</b>													
								<b>215 RPM</b>		<b>175 RPM</b>		<b>130 RPM</b>	
9.84	2,285	C402_0066	MR160/050	56C	AW160/012	6.648	1,146	8.15	2,285	6.52	2,285	4.89	2,285
9.84	2,285	C402_0066	MR160/140	143/145TC	AW160/012	6.648	1,146	8.15	2,285	6.52	2,285	4.89	2,285
9.84	2,287	C502_0067	MR160/050	56C	AW160/012	6.655	1,406	8.15	2,287	6.52	2,287	4.89	2,287
9.84	2,287	C502_0067	MR160/140	143/145TC	AW160/012	6.655	1,406	8.15	2,287	6.52	2,287	4.89	2,287
13.31	3,092	C402_0066	MR200/180	182/184/TC	AW200/014	6.648	1,146	11.74	3,292	10.12	3,547	8.35	3,904
13.31	3,092	C402_0066	MR250/210	213/215/TC	AW250/102	6.648	1,146	11.74	3,292	10.12	3,547	8.35	3,904
19.88	4,624	C502_0067	MR200/180	182/184/TC	AW200/014	6.655	1,406	17.54	4,923	15.12	5,303	11.61	5,432
20.62*	4,795	C502_0067	MR250/180	182/184/TC	AW250/102	6.655	1,406	18.19	5,105	15.68	5,499	12.94	6,053
20.62*	4,795	C502_0067	MR300/250	254/256TC	AW300/110	6.655	1,406	18.19	5,105	15.68	5,499	12.94	6,053
23.36	5,320	C612_0065	MR200/180	182/184/TC	AW200/014	6.518	1,881	19.36	5,320	15.48	5,320	11.61	5,320
35.40*	8,062	C612_0065	MR250/210	213/215/TC	AW250/102	6.518	1,881	29.33	8,062	23.47	8,062	17.60	8,062
38.81*	8,839	C612_0065	MR300/180	182/184/TC	AW300/110	6.518	1,881	34.24	9,411	29.50	10,137	24.36	11,158
74.64*	17,397	C812_0067	MR300/250	254/256TC	AW300/110	6.670	3,547	61.85	17,397	49.48	17,397	37.11	17,397
102.76*	23,950	C812_0067	MR350/360	364/365TC	AW350/202	6.670	3,547	90.66	25,500	78.12	27,469	61.12	28,655
122.95*	27,994	C912_0065	MR350/320	324/326TC	AW350/202	6.516	4,349	101.87	27,994	81.50	27,994	61.12	27,994
<b>255 RPM Output (Approximate)</b>													
								<b>210 RPM</b>		<b>170 RPM</b>		<b>125 RPM</b>	
23.36	5,560	C712_0068	MR200/180	182/184/TC	AW200/014	6.811	2,615	19.36	5,560	15.48	5,560	11.61	5,560
37.06	8,821	C712_0068	MR250/180	182/184/TC	AW250/102	6.811	2,615	30.71	8,821	24.57	8,821	18.43	8,821
62.38*	14,846	C712_0068	MR300/250	254/256TC	AW300/110	6.811	2,615	55.03	15,806	46.95	16,855	35.21	16,855
<b>245 RPM Output (Approximate) Continued Next Page</b>													
								<b>200 RPM</b>		<b>160 RPM</b>		<b>120 RPM</b>	
23.36	6,005	C712_0074	MR200/180	182/184/TC	AW200/014	7.357	2,665	19.36	6,005	15.48	6,005	11.61	6,005
23.36	5,804	C612_0071	MR200/180	182/184/TC	AW200/014	7.111	1,922	19.36	5,804	15.48	5,804	11.61	5,804
36.62*	9,099	C612_0071	MR250/180	182/184/TC	AW250/102	7.111	1,922	30.47	9,136	24.37	9,136	18.28	9,136
36.62*	9,099	C612_0071	MR300/180	182/184/TC	AW300/110	7.111	1,922	32.31	9,688	27.84	10,436	22.98	11,486
38.46	9,886	C712_0074	MR250/180	182/184/TC	AW250/102	7.357	2,665	31.87	9,886	25.49	9,886	19.12	9,886

### Part No. Explanation

**C 3 0 2 N 0620 AW 140 /012**

Unit No.  
Concentric Helical

Generation No.  
No. of Gear Reductions

Housing Style  
Ratio (0620 = 62.0:1)

Input Shaft  
Shaft Dia. (1/16 in.; example- 012=12/16 or 3/4)

Flange No.

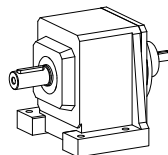

**C 3 0 2 N 0620 MR 160 /140**

Unit No.  
Concentric Helical

Generation No.  
No. of Reductions

Housing Style  
Ratio (0620 = 62.0:1)

Motor Adapter  
Motor Frame Size (140=143/145TC)

Flange No.

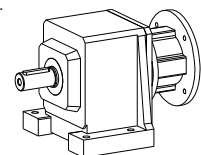

**Mounting position must be specified when ordering.**



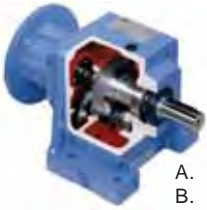

# "C" Series – Concentric Helical MGS Reducer – Selection Data



## Selection Procedure:

- Under the Input RPM heading, find **Approximate Output RPM** nearest the requirement.
- In the **Input HP** column locate the rating that is greater than or equal to the required HP.  
(If selection is based on Torque instead of HP, find an **Output Torque** that is equal to or greater than required.)
- When HP or Torque rating is located, read across that row to select the **Base Module**, **Input Option** and **Overhung Loads**.
- If exact **Output RPM** is required, divide the **Input RPM** by the **Exact Ratio**.

1750 RPM Input		Base Module <sup>1)</sup>	Input Options <sup>2)</sup>			Exact Ratio	Overhung Load Output Shaft <sup>3)</sup> lbs.	1450 RPM Input		1160 RPM Input		870 RPM Input	
Input HP	Output Torque in. lbs.		Motor Adapter	NEMA C-Frame Size <sup>4)</sup>	Input Shaft			Input HP	Output Torque in. lbs.	Input HP	Output Torque in. lbs.	Input HP	Output Torque in. lbs.
<b>245 RPM Output (Approximate) Continued</b>													
<b>200 RPM      160 RPM      120 RPM</b>													
59.25*	15,232	<b>C712_0074</b>	<b>MR300/250</b>	254/256TC	<b>AW300/110</b>	7.357	2,665	52.27	16,218	45.05	17,470	34.26	17,716
77.01*	19,654	<b>C812_0073</b>	<b>MR300/250</b>	254/256TC	<b>AW300/110</b>	7.304	3,628	63.81	19,654	51.05	19,654	38.28	19,654
96.73*	24,686	<b>C812_0073</b>	<b>MR350/320</b>	324/326TC	<b>AW350/202</b>	7.304	3,628	85.33	26,283	73.54	28,313	60.70	31,162
122.95*	31,817	<b>C912_0074</b>	<b>MR350/360</b>	364/365TC	<b>AW350/202</b>	7.406	4,490	101.87	31,817	81.50	31,817	61.12	31,817
<b>225 RPM Output (Approximate)</b>													
<b>185 RPM      150 RPM      110 RPM</b>													
1.66	447	<b>C002_0077</b>	<b>MR140/050</b>	56C	<b>AW140/010</b>	7.714	233	1.46	476	1.26	512	1.04	564
1.66	447	<b>C002_0077</b>	<b>MR160/050</b>	56C	<b>AW160/012</b>	7.714	233	1.46	476	1.26	512	1.04	564
1.66	447	<b>C002_0077</b>	<b>MR160/140</b>	143/145TC	<b>AW160/012</b>	7.714	233	1.46	476	1.26	512	1.04	564
2.23	607	<b>C102_0078</b>	<b>MR140/050</b>	56C	<b>AW140/010</b>	7.796	332	1.85	607	1.48	607	1.11	607
2.29	625	<b>C202_0078</b>	<b>MR140/050</b>	56C	<b>AW140/010</b>	7.800	467	1.90	625	1.52	625	1.14	625
3.29	897	<b>C102_0078</b>	<b>MR160/050</b>	56C	<b>AW160/012</b>	7.796	332	2.90	955	2.50	1,029	2.07	1,132
3.29	897	<b>C102_0078</b>	<b>MR160/140</b>	143/145TC	<b>AW160/012</b>	7.796	332	2.90	955	2.50	1,029	2.07	1,132
3.29	897	<b>C102_0078</b>	<b>MR200/180</b>	182/184TC	<b>AW200/014</b>	7.796	332	2.90	955	2.50	1,029	2.07	1,132
5.03	1,370	<b>C202_0078</b>	<b>MR160/050</b>	56C	<b>AW160/012</b>	7.800	467	4.43	1,458	3.82	1,571	3.15	1,729
5.03	1,370	<b>C202_0078</b>	<b>MR160/140</b>	143/145TC	<b>AW160/012</b>	7.800	467	4.43	1,458	3.82	1,571	3.15	1,729
5.03	1,370	<b>C202_0078</b>	<b>MR200/180</b>	182/184TC	<b>AW200/014</b>	7.800	467	4.43	1,458	3.82	1,571	3.15	1,729
6.98	1,912	<b>C302_0078</b>	<b>MR160/050</b>	56C	<b>AW160/012</b>	7.841	696	6.16	2,035	5.30	2,193	4.38	2,413
6.98	1,912	<b>C302_0078</b>	<b>MR160/140</b>	143/145TC	<b>AW160/012</b>	7.841	696	6.16	2,035	5.30	2,193	4.38	2,413
8.15	2,225	<b>C402_0078</b>	<b>MR160/050</b>	56C	<b>AW160/012</b>	7.816	1,193	7.19	2,369	6.19	2,552	4.89	2,686
8.15	2,225	<b>C402_0078</b>	<b>MR160/140</b>	143/145TC	<b>AW160/012</b>	7.816	1,193	7.19	2,369	6.19	2,552	4.89	2,686
8.20	2,246	<b>C302_0078</b>	<b>MR200/180</b>	182/184TC	<b>AW200/014</b>	7.841	696	7.23	2,392	6.23	2,576	4.87	2,685
8.20	2,246	<b>C302_0078</b>	<b>MR250/180</b>	182/184TC	<b>AW250/102</b>	7.841	696	7.23	2,392	6.23	2,576	4.87	2,685
9.69	2,630	<b>C502_0078</b>	<b>MR160/050</b>	56C	<b>AW160/012</b>	7.763	1,461	8.15	2,668	6.52	2,668	4.89	2,668
9.69	2,630	<b>C502_0078</b>	<b>MR160/140</b>	143/145TC	<b>AW160/012</b>	7.763	1,461	8.15	2,668	6.52	2,668	4.89	2,668
11.95	3,264	<b>C402_0078</b>	<b>MR200/180</b>	182/184TC	<b>AW200/014</b>	7.816	1,193	10.54	3,475	9.09	3,743	7.50	4,120
11.95	3,264	<b>C402_0078</b>	<b>MR250/180</b>	182/184TC	<b>AW250/102</b>	7.816	1,193	10.54	3,475	9.09	3,743	7.50	4,120
16.28	4,416	<b>C502_0078</b>	<b>MR200/180</b>	182/184TC	<b>AW200/014</b>	7.763	1,461	14.36	4,702	12.38	5,065	10.22	5,574
18.61	5,047	<b>C502_0078</b>	<b>MR250/210</b>	213/215TC	<b>AW250/102</b>	7.763	1,461	16.42	5,374	14.15	5,789	11.68	6,372
18.61	5,047	<b>C502_0078</b>	<b>MR300/250</b>	254/256TC	<b>AW300/110</b>	7.763	1,461	16.42	5,374	14.15	5,789	11.68	6,372
<b>210 RPM Output (Approximate) Continued Next Page</b>													
<b>175 RPM      140 RPM      105 RPM</b>													
1.85	531	<b>C002_0082</b>	<b>MR140/050</b>	56C	<b>AW140/010</b>	8.235	237	1.53	531	1.22	531	0.92	531
1.85	531	<b>C002_0082</b>	<b>MR160/050</b>	56C	<b>AW160/012</b>	8.235	237	1.53	531	1.22	531	0.92	531
1.85	531	<b>C002_0082</b>	<b>MR160/140</b>	143/145TC	<b>AW160/012</b>	8.235	237	1.53	531	1.22	531	0.92	531
2.61	754	<b>C102_0083</b>	<b>MR140/050</b>	56C	<b>AW140/010</b>	8.263	337	2.16	754	1.73	754	1.30	754
3.68	1,063	<b>C102_0083</b>	<b>MR160/050</b>	56C	<b>AW160/012</b>	8.263	337	3.05	1,063	2.44	1,063	1.83	1,063
3.68	1,063	<b>C102_0083</b>	<b>MR160/140</b>	143/145TC	<b>AW160/012</b>	8.263	337	3.05	1,063	2.44	1,063	1.83	1,063
3.68	1,063	<b>C102_0083</b>	<b>MR200/180</b>	182/184TC	<b>AW200/014</b>	8.263	337	3.05	1,063	2.44	1,063	1.83	1,063
6.18	1,770	<b>C202_0082</b>	<b>MR160/050</b>	56C	<b>AW160/012</b>	8.190	473	5.13	1,772	4.10	1,772	3.08	1,772

\* For thermal HP capacity, see rating below.

Base Module	C0	C1	C2	C3	C4	C5	C6	C7	C8	C9
Thermal Capacity	2.95	5.36	7.38	12.34	14.75	20.12	29.50	40.23	53.64	67.05

NEMA Frame Size  
TEFC 1750 RPM

C-Frame	Motor HP
56C	1/3 - 1 1/2
143/145TC	1, 1 1/2, 2
182/184TC	3, 5
213/215TC	7 1/2, 10
254/256TC	15, 20
284/286TC	25, 30
324/326TC	40, 50
364/365TC	60, 75

## Housing Styles

**N** – Foot Mounted    **F** – Round Flange    **Q** – Square Flange    **G** – Tapped Holes

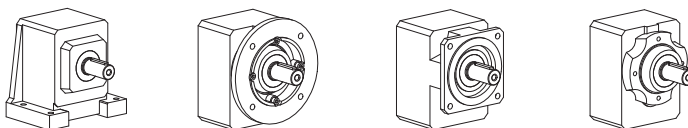

Housing Style Q is available on special order.



# "C" Series – Concentric Helical MGS Reducer – Selection Data



- NOTE:** 1) Complete Base Module Part Number by adding Housing Style. Example: C302N0560.  
 2) Select Input Option and add to completed Part Number. See example below.  
 3) Overhung Load is measured at the center of the shaft extension. Hollow output units are not intended to support overhung loads. If a load rating is required, use 50% of the published overhung load.  
 4) Other frame sizes may also be available. See dimension pages.

1750 RPM Input		Base Module <sup>1)</sup>	Input Options <sup>2)</sup>			Exact Ratio	Overhung Load Output Shaft <sup>3)</sup> lbs.	1450 RPM Input		1160 RPM Input		870 RPM Input	
Input HP	Output Torque in. lbs.		Motor Adapter	NEMA C-Frame Size <sup>4)</sup>	Input Shaft			Input HP	Output Torque in. lbs.	Input HP	Output Torque in. lbs.	Input HP	Output Torque in. lbs.
<b>210 RPM Output (Approximate) Continued</b>													
								<b>175 RPM</b>	<b>140 RPM</b>	<b>105 RPM</b>			
6.18	1,770	C202_0082	MR160/140	143/145TC	AW160/012	8.190	473	5.13	1,772	4.10	1,772	3.08	1,772
6.18	1,770	C202_0082	MR200/180	182/184/TC	AW200/014	8.190	473	5.13	1,772	4.10	1,772	3.08	1,772
9.57	2,758	C302_0083	MR160/050	56C	AW160/012	8.250	704	8.15	2,835	6.52	2,835	4.89	2,835
9.57	2,758	C302_0083	MR160/140	143/145TC	AW160/012	8.250	704	8.15	2,835	6.52	2,835	4.89	2,835
9.57	2,758	C302_0083	MR200/180	182/184/TC	AW200/014	8.250	704	8.44	2,936	7.13	3,100	5.35	3,100
9.57	2,758	C302_0083	MR250/180	182/184/TC	AW250/102	8.250	704	8.44	2,936	7.13	3,100	5.35	3,100
16.01*	4,634	C402_0083	MR200/180	182/184/TC	AW200/014	8.285	1,211	13.94	4,872	11.16	4,872	8.37	4,872
16.01*	4,634	C402_0083	MR250/180	182/184/TC	AW250/102	8.285	1,211	13.94	4,872	11.16	4,872	8.37	4,872
23.36*	6,745	C502_0083	MR200/180	182/184/TC	AW200/014	8.263	1,484	19.36	6,745	15.48	6,745	11.61	6,745
23.36	6,685	C612_0082	MR200/180	182/184/TC	AW200/014	8.190	1,991	19.36	6,685	15.48	6,685	11.61	6,685
24.05*	6,945	C502_0083	MR250/180	182/184/TC	AW250/102	8.263	1,484	20.34	7,086	16.27	7,086	12.20	7,086
24.05*	6,945	C502_0083	MR300/250	254/256TC	AW300/110	8.263	1,484	20.34	7,086	16.27	7,086	12.20	7,086
33.33*	9,538	C612_0082	MR250/180	182/184/TC	AW250/102	8.190	1,991	28.34	9,790	22.68	9,790	17.01	9,790
33.33*	9,538	C612_0082	MR300/180	182/184/TC	AW300/110	8.190	1,991	29.40	10,155	25.34	10,939	20.92	12,040
122.95*	35,606	C912_0083	MR350/360	364/365TC	AW350/202	8.288	4,618	101.87	35,606	81.50	35,606	61.12	35,606
<b>205 RPM Output (Approximate)</b>													
								<b>170 RPM</b>	<b>135 RPM</b>	<b>100 RPM</b>			
23.36	6,930	C712_0085	MR200/180	182/184/TC	AW200/014	8.490	2,763	19.36	6,930	15.48	6,930	11.61	6,930
35.72	10,597	C712_0085	MR250/210	213/215/TC	AW250/102	8.490	2,763	29.60	10,597	23.68	10,597	17.76	10,597
53.86*	15,977	C712_0085	MR300/250	254/256TC	AW300/110	8.490	2,763	47.51	17,011	40.94	18,325	33.80	20,169
71.75*	21,240	C812_0085	MR300/250	254/256TC	AW300/110	8.472	3,765	59.45	21,240	47.56	21,240	35.67	21,240
87.62*	25,938	C812_0085	MR350/320	324/326TC	AW350/202	8.472	3,765	77.30	27,616	66.61	29,748	54.99	32,742
<b>200 RPM Output (Approximate)</b>													
								<b>160 RPM</b>	<b>130 RPM</b>	<b>95 RPM</b>			
23.36	7,443	C612_0091	MR200/180	182/184/TC	AW200/014	9.118	2,045	19.36	7,443	15.48	7,443	11.61	7,443
31.03*	9,885	C612_0091	MR250/180	182/184/TC	AW250/102	9.118	2,045	27.37	10,525	23.46	11,278	17.60	11,278
31.03*	9,885	C612_0091	MR300/180	182/184/TC	AW300/110	9.118	2,045	27.37	10,525	23.59	11,338	17.97	11,515
74.64*	23,586	C812_0090	MR300/250	254/256TC	AW300/110	9.043	3,827	61.85	23,586	49.48	23,586	37.11	23,586
83.89*	26,508	C812_0090	MR350/320	324/326TC	AW350/202	9.043	3,827	74.01	28,223	63.78	30,402	50.17	31,889
<b>190 RPM Output (Approximate) Continued Next Page</b>													
								<b>155 RPM</b>	<b>125 RPM</b>	<b>90 RPM</b>			
1.65	531	C002_0092	MR140/050	56C	AW140/010	9.228	244	1.37	531	1.09	531	0.82	531
1.65	531	C002_0092	MR160/050	56C	AW160/012	9.228	244	1.37	531	1.09	531	0.82	531
1.65	531	C002_0092	MR160/140	143/145TC	AW160/012	9.228	244	1.37	531	1.09	531	0.82	531
2.61	851	C102_0093	MR140/050	56C	AW140/010	9.326	347	2.16	851	1.73	851	1.30	851
3.26	1,063	C102_0093	MR160/050	56C	AW160/012	9.326	347	2.70	1,063	2.16	1,063	1.62	1,063
3.26	1,063	C102_0093	MR160/140	143/145TC	AW160/012	9.326	347	2.70	1,063	2.16	1,063	1.62	1,063
3.26	1,063	C102_0093	MR200/180	182/184/TC	AW200/014	9.326	347	2.70	1,063	2.16	1,063	1.62	1,063
5.40	1,772	C202_0094	MR160/050	56C	AW160/012	9.387	489	4.48	1,772	3.58	1,772	2.69	1,772
5.40	1,772	C202_0094	MR160/140	143/145TC	AW160/012	9.387	489	4.48	1,772	3.58	1,772	2.69	1,772
5.40	1,772	C202_0094	MR200/180	182/184/TC	AW200/014	9.387	489	4.48	1,772	3.58	1,772	2.69	1,772

### Part No. Explanation

**C 3 0 2 N 0620 AW 140 / 012**

Unit No.  
 Concentric Helical  
 Generation No.  
 No. of Gear Reductions  
 Housing Style  
 Ratio (0620 = 62.0:1)  
 Input Shaft  
 Flange No.  
 Shaft Dia. (1/16 in.; example- 012=12/16 or 3/4)

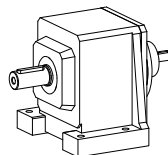

**C 3 0 2 N 0620 MR 160 / 140**

Unit No.  
 Concentric Helical  
 Generation No.  
 No. of Reductions  
 Housing Style  
 Ratio (0620 = 62.0:1)  
 Motor Adapter  
 Flange No.  
 Motor Frame Size (140=143/145TC)

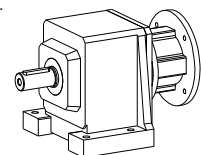

**Mounting position must be specified when ordering.**



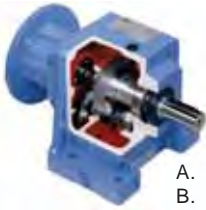

# "C" Series – Concentric Helical MGS Reducer – Selection Data



## Selection Procedure:

- Under the Input RPM heading, find **Approximate Output RPM** nearest the requirement.
- In the **Input HP** column locate the rating that is greater than or equal to the required HP.  
(If selection is based on Torque instead of HP, find an **Output Torque** that is equal to or greater than required.)
- When HP or Torque rating is located, read across that row to select the **Base Module**, **Input Option** and **Overhung Loads**.
- If exact **Output RPM** is required, divide the **Input RPM** by the **Exact Ratio**.

1750 RPM Input		Base Module <sup>1)</sup>	Input Options <sup>2)</sup>			Exact Ratio	Overhung Load Output Shaft <sup>3)</sup> lbs.	1450 RPM Input		1160 RPM Input		870 RPM Input	
Input HP	Output Torque in. lbs.		Motor Adapter	NEMA C-Frame Size <sup>4)</sup>	Input Shaft			Input HP	Output Torque in. lbs.	Input HP	Output Torque in. lbs.	Input HP	Output Torque in. lbs.
<b>190 RPM Output (Approximate) Continued</b>													
8.83	2,871	<b>C302_0093</b>	<b>MR160/050</b>	56C	<b>AW160/012</b>	9.310	726	7.79	3,057	6.32	3,100	4.74	3,100
8.83	2,871	<b>C302_0093</b>	<b>MR160/140</b>	143/145TC	<b>AW160/012</b>	9.310	726	7.79	3,057	6.32	3,100	4.74	3,100
8.83	2,871	<b>C302_0093</b>	<b>MR200/180</b>	182/184TC	<b>AW200/014</b>	9.310	726	7.79	3,057	6.32	3,100	4.74	3,100
8.83	2,871	<b>C302_0093</b>	<b>MR250/180</b>	182/184TC	<b>AW250/102</b>	9.310	726	7.79	3,057	6.32	3,100	4.74	3,100
14.86*	4,809	<b>C402_0093</b>	<b>MR200/180</b>	182/184TC	<b>AW200/014</b>	9.261	1,245	12.47	4,872	9.98	4,872	7.48	4,872
14.86*	4,809	<b>C402_0093</b>	<b>MR250/180</b>	182/184TC	<b>AW250/102</b>	9.261	1,245	12.47	4,872	9.98	4,872	7.48	4,872
21.90*	7,086	<b>C502_0093</b>	<b>MR200/180</b>	182/184TC	<b>AW200/014</b>	9.261	1,527	18.14	7,086	14.52	7,086	10.89	7,086
21.90*	7,086	<b>C502_0093</b>	<b>MR250/210</b>	213/215TC	<b>AW250/102</b>	9.261	1,527	18.14	7,086	14.52	7,086	10.89	7,086
21.90*	7,086	<b>C502_0093</b>	<b>MR300/180</b>	182/184TC	<b>AW300/110</b>	9.261	1,527	18.14	7,086	14.52	7,086	10.89	7,086
23.36*	7,701	<b>C712_0094</b>	<b>MR200/180</b>	182/184TC	<b>AW200/014</b>	9.435	2,837	19.36	7,701	15.48	7,701	11.61	7,701
37.06*	12,219	<b>C712_0094</b>	<b>MR250/180</b>	182/184TC	<b>AW250/102</b>	9.435	2,837	30.71	12,219	24.57	12,219	18.43	12,219
50.20*	16,549	<b>C712_0094</b>	<b>MR300/250</b>	254/256TC	<b>AW300/110</b>	9.435	2,837	44.28	17,620	35.62	17,716	26.72	17,716
122.95*	39,774	<b>C912_0093</b>	<b>MR350/320</b>	324/326TC	<b>AW350/202</b>	9.258	4,748	101.87	39,774	81.50	39,774	61.12	39,774

<b>175 RPM Output (Approximate)</b>													
23.36	8,253	<b>C612_0100</b>	<b>MR200/180</b>	182/184TC	<b>AW200/014</b>	10.111	2,099	19.36	8,253	15.48	8,253	11.61	8,253
23.36	8,091	<b>C712_0099</b>	<b>MR200/180</b>	182/184TC	<b>AW200/014</b>	9.912	2,872	19.36	8,091	15.48	8,091	11.61	8,091
28.96	10,232	<b>C612_0100</b>	<b>MR250/210</b>	213/215TC	<b>AW250/102</b>	10.111	2,099	25.55	10,894	21.87	11,657	16.40	11,657
28.96	10,232	<b>C612_0100</b>	<b>MR300/210</b>	213/215TC	<b>AW300/110</b>	10.111	2,099	25.55	10,894	22.02	11,735	18.07	12,844
34.84	12,068	<b>C712_0099</b>	<b>MR250/180</b>	182/184TC	<b>AW250/102</b>	9.912	2,872	28.87	12,068	23.10	12,068	17.32	12,068
48.58*	16,824	<b>C712_0099</b>	<b>MR300/250</b>	254/256TC	<b>AW300/110</b>	9.912	2,872	42.85	17,912	36.93	19,295	30.48	21,237
69.49*	24,648	<b>C812_0100</b>	<b>MR300/250</b>	254/256TC	<b>AW300/110</b>	10.151	3,939	57.58	24,648	46.06	24,648	34.55	24,648
77.67*	27,549	<b>C812_0100</b>	<b>MR350/320</b>	324/326TC	<b>AW350/202</b>	10.151	3,939	68.52	29,331	59.05	31,596	48.74	34,776
122.95*	42,055	<b>C912_0098</b>	<b>MR350/320</b>	324/326TC	<b>AW350/202</b>	9.789	4,815	101.87	42,055	81.50	42,055	61.12	42,055

<b>170 RPM Output (Approximate) Continued Next Page</b>													
1.48	531	<b>C002_0105</b>	<b>MR140/050</b>	56C	<b>AW140/010</b>	10.297	250	1.22	531	0.98	531	0.73	531
1.48	531	<b>C002_0105</b>	<b>MR160/050</b>	56C	<b>AW160/012</b>	10.297	250	1.22	531	0.98	531	0.73	531
1.48	531	<b>C002_0105</b>	<b>MR160/140</b>	143/145TC	<b>AW160/012</b>	10.297	250	1.22	531	0.98	531	0.73	531
2.52	914	<b>C102_0105</b>	<b>MR140/050</b>	56C	<b>AW140/010</b>	10.383	357	2.09	914	1.67	914	1.25	914
2.93	1,063	<b>C102_0105</b>	<b>MR160/050</b>	56C	<b>AW160/012</b>	10.383	357	2.43	1,063	1.94	1,063	1.46	1,063
2.93	1,063	<b>C102_0105</b>	<b>MR160/140</b>	143/145TC	<b>AW160/012</b>	10.383	357	2.43	1,063	1.94	1,063	1.46	1,063
2.93	1,063	<b>C102_0105</b>	<b>MR200/180</b>	182/184TC	<b>AW200/014</b>	10.383	357	2.43	1,063	1.94	1,063	1.46	1,063
4.94	1,772	<b>C202_0105</b>	<b>MR160/050</b>	56C	<b>AW160/012</b>	10.260	500	4.09	1,772	3.28	1,772	2.46	1,772
4.94	1,772	<b>C202_0105</b>	<b>MR160/140</b>	143/145TC	<b>AW160/012</b>	10.260	500	4.09	1,772	3.28	1,772	2.46	1,772
4.94	1,772	<b>C202_0105</b>	<b>MR200/180</b>	182/184TC	<b>AW200/014</b>	10.260	500	4.09	1,772	3.28	1,772	2.46	1,772
8.26	2,968	<b>C302_0105</b>	<b>MR160/050</b>	56C	<b>AW160/012</b>	10.286	744	7.15	3,100	5.72	3,100	4.29	3,100
8.26	2,968	<b>C302_0105</b>	<b>MR160/140</b>	143/145TC	<b>AW160/012</b>	10.286	744	7.15	3,100	5.72	3,100	4.29	3,100
8.26	2,968	<b>C302_0105</b>	<b>MR200/180</b>	182/184TC	<b>AW200/014</b>	10.286	744	7.15	3,100	5.72	3,100	4.29	3,100
8.26	2,968	<b>C302_0105</b>	<b>MR250/180</b>	182/184TC	<b>AW250/102</b>	10.286	744	7.15	3,100	5.72	3,100	4.29	3,100

\* For thermal HP capacity, see rating below.

Base Module	C0	C1	C2	C3	C4	C5	C6	C7	C8	C9
Thermal Capacity	2.95	5.36	7.38	12.34	14.75	20.12	29.50	40.23	53.64	67.05

## NEMA Frame Size TEFC 1750 RPM

C-Frame	Motor HP
56C	1/3 - 1 1/2
143/145TC	1, 1 1/2, 2
182/184TC	3, 5
213/215TC	7 1/2, 10
254/256TC	15, 20
284/286TC	25, 30
324/326TC	40, 50
364/365TC	60, 75

## Housing Styles

N – Foot Mounted    F – Round Flange    Q – Square Flange    G – Tapped Holes

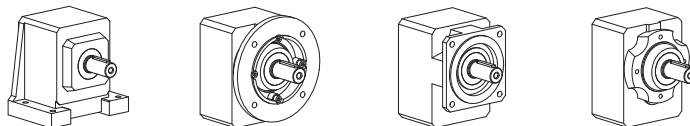

Housing Style Q is available on special order.



# "C" Series – Concentric Helical MGS Reducer – Selection Data



- NOTE:** 1) Complete Base Module Part Number by adding Housing Style. Example: C302N0560.  
 2) Select Input Option and add to completed Part Number. See example below.  
 3) Overhung Load is measured at the center of the shaft extension. Hollow output units are not intended to support overhung loads. If a load rating is required, use 50% of the published overhung load.  
 4) Other frame sizes may also be available. See dimension pages.

1750 RPM Input		Base Module 1)	Input Options 2)			Exact Ratio	Overhung Load Output Shaft <sup>3)</sup> lbs.	1450 RPM Input		1160 RPM Input		870 RPM Input	
Input HP	Output Torque in. lbs.		Motor Adapter	NEMA C-Frame Size 4)	Input Shaft			Input HP	Output Torque in. lbs.	Input HP	Output Torque in. lbs.	Input HP	Output Torque in. lbs.
<b>170 RPM Output (Approximate) Continued</b>													
9.84	3,578	C402_0105	MR160/050	56C	AW160/012	10.410	1,282	8.15	3,578	6.52	3,578	4.89	3,578
9.84	3,578	C402_0105	MR160/140	143/145TC	AW160/012	10.410	1,282	8.15	3,578	6.52	3,578	4.89	3,578
13.39	4,872	C402_0105	MR200/180	182/184TC	AW200/014	10.410	1,282	11.10	4,872	8.88	4,872	6.66	4,872
13.39	4,872	C402_0105	MR250/180	182/184TC	AW250/102	10.410	1,282	11.10	4,872	8.88	4,872	6.66	4,872
19.53	7,086	C502_0105	MR200/180	182/184TC	AW200/014	10.383	1,571	16.18	7,086	12.95	7,086	9.71	7,086
19.53	7,086	C502_0105	MR250/180	182/184TC	AW250/102	10.383	1,571	16.18	7,086	12.95	7,086	9.71	7,086
19.53	7,086	C502_0105	MR300/280	284/286TC	AW300/110	10.383	1,571	16.18	7,086	12.95	7,086	9.71	7,086
<b>150 RPM Output (Approximate)</b>													
1.32	531	C002_0115	MR140/050	56C	AW140/010	11.540	258	1.09	531	0.87	531	0.66	531
1.32	531	C002_0115	MR160/050	56C	AW160/012	11.540	258	1.09	531	0.87	531	0.66	531
1.32	531	C002_0115	MR160/140	143/145TC	AW160/012	11.540	258	1.09	531	0.87	531	0.66	531
2.52	1,032	C102_0115	MR140/050	56C	AW140/010	11.717	367	2.09	1,032	1.67	1,032	1.25	1,032
2.60	1,063	C102_0115	MR160/050	56C	AW160/012	11.717	367	2.15	1,063	1.72	1,063	1.29	1,063
2.60	1,063	C102_0115	MR160/140	143/145TC	AW160/012	11.717	367	2.15	1,063	1.72	1,063	1.29	1,063
2.60	1,063	C102_0115	MR200/180	182/184TC	AW200/014	11.717	367	2.15	1,063	1.72	1,063	1.29	1,063
7.62	3,090	C302_0115	MR160/050	56C	AW160/012	11.607	767	6.33	3,100	5.07	3,100	3.80	3,100
7.62	3,090	C302_0115	MR160/140	143/145TC	AW160/012	11.607	767	6.33	3,100	5.07	3,100	3.80	3,100
7.62	3,090	C302_0115	MR200/180	182/184TC	AW200/014	11.607	767	6.33	3,100	5.07	3,100	3.80	3,100
7.62	3,090	C302_0115	MR250/180	182/184TC	AW250/102	11.607	767	6.33	3,100	5.07	3,100	3.80	3,100
9.84	3,999	C402_0115	MR160/050	56C	AW160/012	11.636	1,318	8.15	3,999	6.52	3,999	4.89	3,999
9.84	3,999	C402_0115	MR160/140	143/145TC	AW160/012	11.636	1,318	8.15	3,999	6.52	3,999	4.89	3,999
11.98	4,872	C402_0115	MR200/180	182/184TC	AW200/014	11.636	1,318	9.93	4,872	7.94	4,872	5.96	4,872
11.98	4,872	C402_0115	MR250/180	182/184TC	AW250/102	11.636	1,318	9.93	4,872	7.94	4,872	5.96	4,872
17.43	7,086	C502_0115	MR200/180	182/184TC	AW200/014	11.636	1,617	14.44	7,086	11.55	7,086	8.66	7,086
17.43	7,086	C502_0115	MR250/180	182/184TC	AW250/102	11.636	1,617	14.44	7,086	11.55	7,086	8.66	7,086
17.43	7,086	C502_0115	MR300/180	182/184TC	AW300/110	11.636	1,617	14.44	7,086	11.55	7,086	8.66	7,086
23.36	9,352	C612_0115	MR200/180	182/184TC	AW200/014	11.457	2,166	19.36	9,352	15.48	9,352	11.61	9,352
26.65	10,667	C612_0115	MR250/180	182/184TC	AW250/102	11.457	2,166	23.51	11,357	19.07	11,515	14.30	11,515
26.65	10,667	C612_0115	MR300/250	254/256TC	AW300/110	11.457	2,166	23.51	11,357	19.07	11,515	14.30	11,515
71.52*	28,708	C812_0115	MR300/250	254/256TC	AW300/110	11.487	4,063	59.45	28,798	47.56	28,798	35.67	28,798
71.52*	28,708	C812_0115	MR350/320	324/326TC	AW350/202	11.487	4,063	63.10	30,565	52.66	31,889	39.50	31,889
<b>145 RPM Output (Approximate)</b>													
4.31	1,772	C202_0120	MR160/050	56C	AW160/012	11.760	518	3.57	1,772	2.86	1,772	2.14	1,772
4.31	1,772	C202_0120	MR160/140	143/145TC	AW160/012	11.760	518	3.57	1,772	2.86	1,772	2.14	1,772
4.31	1,772	C202_0120	MR200/180	182/184TC	AW200/014	11.760	518	3.57	1,772	2.86	1,772	2.14	1,772
23.36	9,600	C712_0120	MR200/180	182/184TC	AW200/014	11.761	2,997	19.36	9,600	15.48	9,600	11.61	9,600
35.72	14,680	C712_0120	MR250/180	182/184TC	AW250/102	11.761	2,997	29.60	14,680	23.68	14,680	17.76	14,680
43.11*	17,716	C712_0120	MR300/180	182/184TC	AW300/110	11.761	2,997	35.72	17,716	28.58	17,716	21.43	17,716
122.95*	50,587	C912_0120	MR350/320	324/326TC	AW350/202	11.775	5,042	101.87	50,587	81.50	50,587	61.12	50,587

### Part No. Explanation

**C 3 0 2 N 0620 AW 140 /012**

Unit No.  
 Concentric Helical  
 Generation No.  
 No. of Gear Reductions  
 Housing Style  
 Ratio (0620 = 62.0:1)  
 Input Shaft  
 Flange No.  
 Shaft Dia. (1/16 in.; example- 012=12/16 or 3/4)

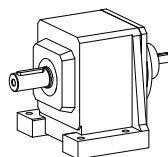

**C 3 0 2 N 0620 MR 160 /140**

Unit No.  
 Concentric Helical  
 Generation No.  
 No. of Reductions  
 Housing Style  
 Ratio (0620 = 62.0:1)  
 Motor Adapter  
 Flange No.  
 Motor Frame Size (140=143/145TC)

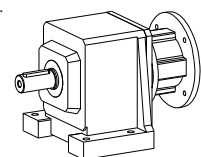

**Mounting position must be specified when ordering.**

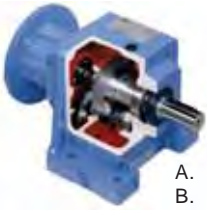

# "C" Series – Concentric Helical MGS Reducer – Selection Data



### Selection Procedure:

- Under the Input RPM heading, find **Approximate Output RPM** nearest the requirement.
- In the **Input HP** column locate the rating that is greater than or equal to the required HP.  
(If selection is based on Torque instead of HP, find an **Output Torque** that is equal to or greater than required.)
- When HP or Torque rating is located, read across that row to select the **Base Module**, **Input Option** and **Overhung Loads**.
- If exact **Output RPM** is required, divide the **Input RPM** by the **Exact Ratio**.

1750 RPM Input		Base Module <sup>1)</sup>	Input Options <sup>2)</sup>			Exact Ratio	Overhung Load Output Shaft <sup>3)</sup> lbs.	1450 RPM Input		1160 RPM Input		870 RPM Input	
Input HP	Output Torque in. lbs.		Motor Adapter	NEMA C-Frame Size <sup>4)</sup>	Input Shaft			Input HP	Output Torque in. lbs.	Input HP	Output Torque in. lbs.	Input HP	Output Torque in. lbs.
<b>140 RPM Output (Approximate)</b>													
1.21	531	<b>C002_0125</b>	<b>MR140/050</b>	56C	<b>AW140/010</b>	12.567	263	1.00	531	0.80	531	0.60	531
1.21	531	<b>C002_0125</b>	<b>MR160/050</b>	56C	<b>AW160/012</b>	12.567	263	1.00	531	0.80	531	0.60	531
1.21	531	<b>C002_0125</b>	<b>MR160/140</b>	143/145TC	<b>AW160/012</b>	12.567	263	1.00	531	0.80	531	0.60	531
2.44	1,062	<b>C102_0125</b>	<b>MR140/050</b>	56C	<b>AW140/010</b>	12.455	373	2.02	1,062	1.62	1,062	1.21	1,062
2.44	1,063	<b>C102_0125</b>	<b>MR160/050</b>	56C	<b>AW160/012</b>	12.455	373	2.02	1,063	1.62	1,063	1.21	1,063
2.44	1,063	<b>C102_0125</b>	<b>MR160/140</b>	143/145TC	<b>AW160/012</b>	12.455	373	2.02	1,063	1.62	1,063	1.21	1,063
2.44	1,063	<b>C102_0125</b>	<b>MR200/180</b>	182/184/TC	<b>AW200/014</b>	12.455	373	2.02	1,063	1.62	1,063	1.21	1,063
4.12	1,772	<b>C202_0125</b>	<b>MR160/050</b>	56C	<b>AW160/012</b>	12.315	524	3.41	1,772	2.73	1,772	2.05	1,772
4.12	1,772	<b>C202_0125</b>	<b>MR160/140</b>	143/145TC	<b>AW160/012</b>	12.315	524	3.41	1,772	2.73	1,772	2.05	1,772
4.12	1,772	<b>C202_0125</b>	<b>MR200/180</b>	182/184/TC	<b>AW200/014</b>	12.315	524	3.41	1,772	2.73	1,772	2.05	1,772
7.16	3,100	<b>C302_0125</b>	<b>MR160/050</b>	56C	<b>AW160/012</b>	12.400	780	5.93	3,100	4.74	3,100	3.56	3,100
7.16	3,100	<b>C302_0125</b>	<b>MR160/140</b>	143/145TC	<b>AW160/012</b>	12.400	780	5.93	3,100	4.74	3,100	3.56	3,100
7.16	3,100	<b>C302_0125</b>	<b>MR200/180</b>	182/184/TC	<b>AW200/014</b>	12.400	780	5.93	3,100	4.74	3,100	3.56	3,100
7.16	3,100	<b>C302_0125</b>	<b>MR250/180</b>	182/184/TC	<b>AW250/102</b>	12.400	780	5.93	3,100	4.74	3,100	3.56	3,100
9.84	4,272	<b>C502_0125</b>	<b>MR160/050</b>	56C	<b>AW160/012</b>	12.429	1,644	8.15	4,272	6.52	4,272	4.89	4,272
9.84	4,272	<b>C502_0125</b>	<b>MR160/140</b>	143/145TC	<b>AW160/012</b>	12.429	1,644	8.15	4,272	6.52	4,272	4.89	4,272
9.84	4,303	<b>C402_0125</b>	<b>MR160/050</b>	56C	<b>AW160/012</b>	12.519	1,342	8.15	4,303	6.52	4,303	4.89	4,303
9.84	4,303	<b>C402_0125</b>	<b>MR160/140</b>	143/145TC	<b>AW160/012</b>	12.519	1,342	8.15	4,303	6.52	4,303	4.89	4,303
11.14	4,872	<b>C402_0125</b>	<b>MR200/180</b>	182/184/TC	<b>AW200/014</b>	12.519	1,342	9.23	4,872	7.38	4,872	5.54	4,872
11.14	4,872	<b>C402_0125</b>	<b>MR250/180</b>	182/184/TC	<b>AW250/102</b>	12.519	1,342	9.23	4,872	7.38	4,872	5.54	4,872
16.32	7,086	<b>C502_0125</b>	<b>MR200/180</b>	182/184/TC	<b>AW200/014</b>	12.429	1,644	13.52	7,086	10.82	7,086	8.11	7,086
16.32	7,086	<b>C502_0125</b>	<b>MR250/180</b>	182/184/TC	<b>AW250/102</b>	12.429	1,644	13.52	7,086	10.82	7,086	8.11	7,086
16.32	7,086	<b>C502_0125</b>	<b>MR300/280</b>	284/286TC	<b>AW300/110</b>	12.429	1,644	13.52	7,086	10.82	7,086	8.11	7,086
22.20	9,759	<b>C612_0125</b>	<b>MR200/180</b>	182/184/TC	<b>AW200/014</b>	12.581	2,217	19.36	10,269	15.48	10,269	11.61	10,269
25.03	11,005	<b>C612_0125</b>	<b>MR250/180</b>	182/184/TC	<b>AW250/102</b>	12.581	2,217	22.08	11,717	19.03	12,622	14.53	12,844
25.03	11,005	<b>C612_0125</b>	<b>MR300/180</b>	182/184/TC	<b>AW300/110</b>	12.581	2,217	22.08	11,717	19.03	12,622	14.53	12,844
34.84	15,522	<b>C812_0125</b>	<b>MR250/210</b>	213/215/TC	<b>AW250/102</b>	12.749	4,170	28.87	15,522	23.10	15,522	17.32	15,522
66.58*	29,660	<b>C812_0125</b>	<b>MR300/180</b>	182/184/TC	<b>AW300/110</b>	12.749	4,170	55.17	29,660	44.13	29,660	33.10	29,660
66.72*	29,723	<b>C812_0125</b>	<b>MR350/360</b>	364/365TC	<b>AW350/202</b>	12.749	4,170	58.86	31,646	50.73	34,090	41.52	37,204
122.95*	53,362	<b>C912_0125</b>	<b>MR350/320</b>	324/326TC	<b>AW350/202</b>	12.421	5,110	101.87	53,362	81.50	53,362	61.12	53,362
<b>130 RPM Output (Approximate)</b>													
23.36	11,207	<b>C712_0135</b>	<b>MR200/180</b>	182/184/TC	<b>AW200/014</b>	13.730	3,115	19.36	11,207	15.48	11,207	11.61	11,207
23.36	10,760	<b>C712_0130</b>	<b>MR200/180</b>	182/184/TC	<b>AW200/014</b>	13.182	3,084	19.36	10,760	15.48	10,760	11.61	10,760
32.99	15,197	<b>C712_0130</b>	<b>MR250/210</b>	213/215/TC	<b>AW250/102</b>	13.182	3,084	27.34	15,197	21.87	15,197	16.40	15,197
34.84	16,716	<b>C712_0135</b>	<b>MR250/180</b>	182/184/TC	<b>AW250/102</b>	13.730	3,115	28.87	16,716	23.10	16,716	17.32	16,716
36.93	17,716	<b>C712_0135</b>	<b>MR300/210</b>	213/215/TC	<b>AW300/110</b>	13.730	3,115	30.60	17,716	24.48	17,716	18.36	17,716
40.17	18,501	<b>C712_0130</b>	<b>MR300/180</b>	182/184/TC	<b>AW300/110</b>	13.182	3,084	35.43	19,698	30.54	21,219	22.95	21,259
<b>105 RPM</b> <b>85 RPM</b> <b>65 RPM</b>													

\* For thermal HP capacity, see rating below.

Base Module	C0	C1	C2	C3	C4	C5	C6	C7	C8	C9
Thermal Capacity	2.95	5.36	7.38	12.34	14.75	20.12	29.50	40.23	53.64	67.05

### NEMA Frame Size TEFC 1750 RPM

C-Frame	Motor HP
56C	1/3 - 1 1/2
143/145TC	1, 1 1/2, 2
182/184TC	3, 5
213/215TC	7 1/2, 10
254/256TC	15, 20
284/286TC	25, 30
324/326TC	40, 50
364/365TC	60, 75

### Housing Styles

**N** – Foot Mounted    **F** – Round Flange    **Q** – Square Flange    **G** – Tapped Holes

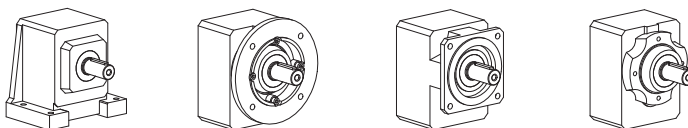

Housing Style Q is available on special order.





# "C" Series – Concentric Helical MGS Reducer – Selection Data



- NOTE:** 1) Complete Base Module Part Number by adding Housing Style. Example: C302N0560.  
 2) Select Input Option and add to completed Part Number. See example below.  
 3) Overhung Load is measured at the center of the shaft extension. Hollow output units are not intended to support overhung loads. If a load rating is required, use 50% of the published overhung load.  
 4) Other frame sizes may also be available. See dimension pages.

1750 RPM Input		Base Module 1)	Input Options 2)			Exact Ratio	Overhung Load Output Shaft <sup>3)</sup> lbs.	1450 RPM Input		1160 RPM Input		870 RPM Input	
Input HP	Output Torque in. lbs.		Motor Adapter	NEMA C-Frame Size 4)	Input Shaft			Input HP	Output Torque in. lbs.	Input HP	Output Torque in. lbs.	Input HP	Output Torque in. lbs.
<b>125 RPM Output (Approximate)</b>													
1.08	531	C002_0140	MR140/050	56C	AW140/010	14.083	271	0.89	531	0.72	531	0.54	531
1.08	531	C002_0140	MR160/050	56C	AW160/012	14.083	271	0.89	531	0.72	531	0.54	531
2.16	1,063	C102_0140	MR140/050	56C	AW140/010	14.056	385	1.79	1,063	1.43	1,063	1.08	1,063
2.16	1,063	C102_0140	MR160/050	56C	AW160/012	14.056	385	1.79	1,063	1.43	1,063	1.08	1,063
2.16	1,063	C102_0140	MR160/140	143/145TC	AW160/012	14.056	385	1.79	1,063	1.43	1,063	1.08	1,063
2.16	1,063	C102_0140	MR200/180	182/184/TC	AW200/014	14.056	385	1.79	1,063	1.43	1,063	1.08	1,063
3.59	1,772	C202_0140	MR160/050	56C	AW160/012	14.115	542	2.98	1,772	2.38	1,772	1.79	1,772
3.59	1,772	C202_0140	MR160/140	143/145TC	AW160/012	14.115	542	2.98	1,772	2.38	1,772	1.79	1,772
3.59	1,772	C202_0140	MR200/180	182/184/TC	AW200/014	14.115	542	2.98	1,772	2.38	1,772	1.79	1,772
6.34	3,100	C302_0140	MR160/050	56C	AW160/012	13.993	804	5.25	3,100	4.20	3,100	3.15	3,100
6.34	3,100	C302_0140	MR160/140	143/145TC	AW160/012	13.993	804	5.25	3,100	4.20	3,100	3.15	3,100
6.34	3,100	C302_0140	MR200/180	182/184/TC	AW200/014	13.993	804	5.25	3,100	4.20	3,100	3.15	3,100
6.34	3,100	C302_0140	MR250/180	182/184/TC	AW250/102	13.993	804	5.25	3,100	4.20	3,100	3.15	3,100
9.84	4,787	C502_0140	MR160/050	56C	AW160/012	13.929	1,691	8.15	4,787	6.52	4,787	4.89	4,787
9.84	4,787	C502_0140	MR160/140	143/145TC	AW160/012	13.929	1,691	8.15	4,787	6.52	4,787	4.89	4,787
9.84	4,809	C402_0140	MR160/050	56C	AW160/012	13.993	1,380	8.15	4,809	6.52	4,809	4.89	4,809
9.84	4,809	C402_0140	MR160/140	143/145TC	AW160/012	13.993	1,380	8.15	4,809	6.52	4,809	4.89	4,809
9.96	4,872	C402_0140	MR200/180	182/184/TC	AW200/014	13.993	1,380	8.26	4,872	6.60	4,872	4.95	4,872
9.96	4,872	C402_0140	MR250/180	182/184/TC	AW250/102	13.993	1,380	8.26	4,872	6.60	4,872	4.95	4,872
14.56	7,086	C502_0140	MR200/180	182/184/TC	AW200/014	13.929	1,691	12.06	7,086	9.65	7,086	7.24	7,086
14.56	7,086	C502_0140	MR250/180	182/184/TC	AW250/102	13.929	1,691	12.06	7,086	9.65	7,086	7.24	7,086
14.56	7,086	C502_0140	MR300/180	182/184/TC	AW300/110	13.929	1,691	12.06	7,086	9.65	7,086	7.24	7,086
23.15	11,444	C612_0140	MR200/180	182/184/TC	AW200/014	14.145	2,283	19.30	11,515	15.44	11,515	11.58	11,515
23.15	11,444	C612_0140	MR250/180	182/184/TC	AW250/102	14.145	2,283	19.30	11,515	15.44	11,515	11.58	11,515
23.15	11,444	C612_0140	MR300/250	254/256TC	AW300/110	14.145	2,283	19.30	11,515	15.44	11,515	11.58	11,515
63.40*	30,491	C812_0140	MR300/250	254/256TC	AW300/110	13.763	4,251	54.94	31,889	43.95	31,889	32.97	31,889
63.40*	30,491	C812_0140	MR350/320	324/326TC	AW350/202	13.763	4,251	54.94	31,889	43.95	31,889	32.97	31,889
109.36*	53,148	C912_0140	MR350/320	324/326TC	AW350/202	13.908	5,257	90.62	53,148	72.49	53,148	54.37	53,148

<b>110 RPM Output (Approximate) Continued Next Page</b>													
<b>90 RPM      75 RPM      55 RPM</b>													
0.97	531	C002_0155	MR140/050	56C	AW140/010	15.637	278	0.81	531	0.64	531	0.48	531
0.97	531	C002_0155	MR160/050	56C	AW160/012	15.637	278	0.81	531	0.64	531	0.48	531
1.94	1,063	C102_0155	MR140/050	56C	AW140/010	15.708	395	1.60	1,063	1.28	1,063	0.96	1,063
1.94	1,063	C102_0155	MR160/050	56C	AW160/012	15.708	395	1.60	1,063	1.28	1,063	0.96	1,063
1.94	1,063	C102_0155	MR160/140	143/145TC	AW160/012	15.708	395	1.60	1,063	1.28	1,063	0.96	1,063
1.94	1,063	C102_0155	MR200/180	182/184/TC	AW200/014	15.708	395	1.60	1,063	1.28	1,063	0.96	1,063
2.42	1,294	C202_0155	MR140/050	56C	AW140/010	15.283	553	2.01	1,294	1.61	1,294	1.20	1,294
3.32	1,772	C202_0155	MR160/050	56C	AW160/012	15.283	553	2.75	1,772	2.20	1,772	1.65	1,772
3.32	1,772	C202_0155	MR160/140	143/145TC	AW160/012	15.283	553	2.75	1,772	2.20	1,772	1.65	1,772
3.32	1,772	C202_0155	MR200/180	182/184/TC	AW200/014	15.283	553	2.75	1,772	2.20	1,772	1.65	1,772

### Part No. Explanation

**C 3 0 2 N 0620 AW 140 / 012**

Unit No.  
Concentric Helical

Generation No.  
No. of Gear Reductions

Housing Style  
Ratio (0620 = 62.0:1)

Input Shaft  
Flange No.

Shaft Dia. (1/16 in.; example- 012=12/16 or 3/4)

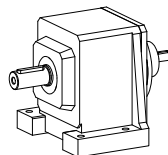

**C 3 0 2 N 0620 MR 160 / 140**

Unit No.  
Concentric Helical

Generation No.  
No. of Reductions

Housing Style  
Ratio (0620 = 62.0:1)

Motor Adapter  
Flange No.

Motor Frame Size (140=143/145TC)

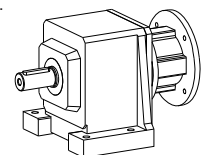

**Mounting position must be specified when ordering.**

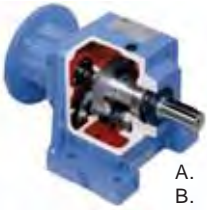

# "C" Series – Concentric Helical MGS Reducer – Selection Data



## Selection Procedure:

- Under the Input RPM heading, find **Approximate Output RPM** nearest the requirement.
- In the **Input HP** column locate the rating that is greater than or equal to the required HP. (If selection is based on Torque instead of HP, find an **Output Torque** that is equal to or greater than required.)
- When HP or Torque rating is located, read across that row to select the **Base Module**, **Input Option** and **Overhung Loads**.
- If exact **Output RPM** is required, divide the **Input RPM** by the **Exact Ratio**.

1750 RPM Input		Base Module <sup>1)</sup>	Input Options <sup>2)</sup>			Exact Ratio	Overhung Load Output Shaft <sup>3)</sup> lbs.	1450 RPM Input		1160 RPM Input		870 RPM Input	
Input HP	Output Torque in. lbs.		Motor Adapter	NEMA C-Frame Size <sup>4)</sup>	Input Shaft			Input HP	Output Torque in. lbs.	Input HP	Output Torque in. lbs.	Input HP	Output Torque in. lbs.

110 RPM Output (Approximate) Continued							90 RPM		75 RPM		55 RPM		
5.71	3,100	C302_0155	MR160/050	56C	AW160/012	15.543	825	4.73	3,100	3.78	3,100	2.84	3,100
5.71	3,100	C302_0155	MR160/140	143/145TC	AW160/012	15.543	825	4.73	3,100	3.78	3,100	2.84	3,100
5.71	3,100	C302_0155	MR200/180	182/184/TC	AW200/014	15.543	825	4.73	3,100	3.78	3,100	2.84	3,100
5.71	3,100	C302_0155	MR250/180	182/184/TC	AW250/102	15.543	825	4.73	3,100	3.78	3,100	2.84	3,100
9.84	5,399	C502_0155	MR160/050	56C	AW160/012	15.708	1,743	8.15	5,399	6.52	5,399	4.89	5,399
9.84	5,399	C502_0155	MR160/140	143/145TC	AW160/012	15.708	1,743	8.15	5,399	6.52	5,399	4.89	5,399
12.91	7,086	C502_0155	MR200/180	182/184/TC	AW200/014	15.708	1,743	10.70	7,086	8.56	7,086	6.42	7,086
12.91	7,086	C502_0155	MR250/180	182/184/TC	AW250/102	15.708	1,743	10.70	7,086	8.56	7,086	6.42	7,086
12.91	7,086	C502_0155	MR300/250	254/256TC	AW300/110	15.708	1,743	10.70	7,086	8.56	7,086	6.42	7,086

105 RPM Output (Approximate)							85 RPM		70 RPM		53 RPM		
8.85	4,872	C402_0160	MR160/050	56C	AW160/012	15.750	1,422	7.33	4,872	5.87	4,872	4.40	4,872
8.85	4,872	C402_0160	MR160/140	143/145TC	AW160/012	15.750	1,422	7.33	4,872	5.87	4,872	4.40	4,872
8.85	4,872	C402_0160	MR200/180	182/184/TC	AW200/014	15.750	1,422	7.33	4,872	5.87	4,872	4.40	4,872
8.85	4,872	C402_0160	MR250/180	182/184/TC	AW250/102	15.750	1,422	7.33	4,872	5.87	4,872	4.40	4,872
18.57	10,514	C612_0160	MR200/180	182/184/TC	AW200/014	16.203	2,362	16.38	11,194	14.12	12,058	11.28	12,844
21.15	11,974	C612_0160	MR250/210	213/215/TC	AW250/102	16.203	2,362	18.66	12,748	15.04	12,844	11.28	12,844
21.15	11,974	C612_0160	MR300/280	284/286TC	AW300/110	16.203	2,362	18.66	12,748	15.04	12,844	11.28	12,844
22.20	12,980	C712_0165	MR200/180	182/184/TC	AW200/014	16.734	3,273	19.36	13,659	15.48	13,659	11.61	13,659
31.67	18,517	C712_0165	MR250/180	182/184/TC	AW250/102	16.734	3,273	26.24	18,517	20.99	18,517	15.74	18,517
32.99	19,716	C812_0170	MR250/180	182/184/TC	AW250/102	17.101	4,488	27.34	19,716	21.87	19,716	16.40	19,716
34.26	20,033	C712_0165	MR300/210	213/215/TC	AW300/110	16.734	3,273	30.13	21,259	24.10	21,259	18.08	21,259
54.86*	32,780	C812_0170	MR300/250	254/256TC	AW300/110	17.101	4,488	48.39	34,901	41.27	37,204	30.95	37,204
54.86*	32,780	C812_0170	MR350/320	324/326TC	AW350/202	17.101	4,488	48.39	34,901	41.27	37,204	30.95	37,204
66.03	37,985	C912_0165	MR300/210	213/215/TC	AW300/110	16.463	5,483	54.71	37,985	43.77	37,985	32.83	37,985
107.79*	62,006	C912_0165	MR350/320	324/326TC	AW350/202	16.463	5,483	89.31	62,006	71.45	62,006	53.59	62,006

100 RPM Output (Approximate) Continued Next Page							80 RPM		65 RPM		50 RPM		
0.87	531	C002_0175	MR140/050	56C	AW140/010	17.525	286	0.72	531	0.58	531	0.43	531
0.87	531	C002_0175	MR160/050	56C	AW160/012	17.525	286	0.72	531	0.58	531	0.43	531
1.72	1,063	C102_0175	MR140/050	56C	AW140/010	17.727	408	1.42	1,063	1.14	1,063	0.85	1,063
1.72	1,063	C102_0175	MR160/050	56C	AW160/012	17.727	408	1.42	1,063	1.14	1,063	0.85	1,063
1.72	1,063	C102_0175	MR160/140	143/145TC	AW160/012	17.727	408	1.42	1,063	1.14	1,063	0.85	1,063
1.72	1,063	C102_0175	MR200/180	182/184/TC	AW200/014	17.727	408	1.42	1,063	1.14	1,063	0.85	1,063
2.42	1,483	C202_0175	MR140/050	56C	AW140/010	17.517	572	2.01	1,483	1.61	1,483	1.20	1,483
2.89	1,772	C202_0175	MR160/050	56C	AW160/012	17.517	572	2.40	1,772	1.92	1,772	1.44	1,772
2.89	1,772	C202_0175	MR160/140	143/145TC	AW160/012	17.517	572	2.40	1,772	1.92	1,772	1.44	1,772
2.89	1,772	C202_0175	MR200/180	182/184/TC	AW200/014	17.517	572	2.40	1,772	1.92	1,772	1.44	1,772
5.06	3,100	C302_0175	MR160/050	56C	AW160/012	17.540	851	4.19	3,100	3.35	3,100	2.51	3,100
5.06	3,100	C302_0175	MR160/140	143/145TC	AW160/012	17.540	851	4.19	3,100	3.35	3,100	2.51	3,100

\* For thermal HP capacity, see rating below.

Base Module	C0	C1	C2	C3	C4	C5	C6	C7	C8	C9
Thermal Capacity	2.95	5.36	7.38	12.34	14.75	20.12	29.50	40.23	53.64	67.05

## NEMA Frame Size TEFC 1750 RPM

C-Frame	Motor HP
56C	1/3 - 1/2
143/145TC	1, 1 1/2, 2
182/184TC	3, 5
213/215TC	7 1/2, 10
254/256TC	15, 20
284/286TC	25, 30
324/326TC	40, 50
364/365TC	60, 75

## Housing Styles

N – Foot Mounted    F – Round Flange    Q – Square Flange    G – Tapped Holes

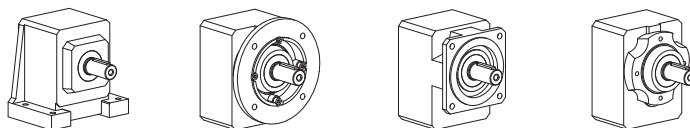

Housing Style Q is available on special order.





# "C" Series – Concentric Helical MGS Reducer – Selection Data



- NOTE:** 1) Complete Base Module Part Number by adding Housing Style. Example: C302N0560.  
 2) Select Input Option and add to completed Part Number. See example below.  
 3) Overhung Load is measured at the center of the shaft extension. Hollow output units are not intended to support overhung loads. If a load rating is required, use 50% of the published overhung load.  
 4) Other frame sizes may also be available. See dimension pages.

1750 RPM Input		Base Module 1)	Input Options 2)			Exact Ratio	Overhung Load Output Shaft <sup>3)</sup> lbs.	1450 RPM Input		1160 RPM Input		870 RPM Input	
Input HP	Output Torque in. lbs.		Motor Adapter	NEMA C-Frame Size 4)	Input Shaft			Input HP	Output Torque in. lbs.	Input HP	Output Torque in. lbs.	Input HP	Output Torque in. lbs.
<b>100 RPM Output (Approximate) Continued</b>													
								<b>80 RPM</b>	<b>65 RPM</b>	<b>50 RPM</b>			
5.06	3,100	C302_0175	MR200/180	182/184/TC	AW200/014	17.540	851	4.19	3,100	3.35	3,100	2.51	3,100
5.06	3,100	C302_0175	MR250/210	213/215/TC	AW250/102	17.540	851	4.19	3,100	3.35	3,100	2.51	3,100
7.92	4,872	C402_0175	MR160/050	56C	AW160/012	17.604	1,462	6.56	4,872	5.25	4,872	3.94	4,872
7.92	4,872	C402_0175	MR160/140	143/145TC	AW160/012	17.604	1,462	6.56	4,872	5.25	4,872	3.94	4,872
7.92	4,872	C402_0175	MR200/180	182/184/TC	AW200/014	17.604	1,462	6.56	4,872	5.25	4,872	3.94	4,872
7.92	4,872	C402_0175	MR250/180	182/184/TC	AW250/102	17.604	1,462	6.56	4,872	5.25	4,872	3.94	4,872
9.84	6,050	C502_0175	MR160/050	56C	AW160/012	17.604	1,793	8.15	6,050	6.52	6,050	4.89	6,050
9.84	6,050	C502_0175	MR160/140	143/145TC	AW160/012	17.604	1,793	8.15	6,050	6.52	6,050	4.89	6,050
11.52	7,086	C502_0175	MR200/180	182/184/TC	AW200/014	17.604	1,793	9.55	7,086	7.64	7,086	5.73	7,086
11.52	7,086	C502_0175	MR250/210	213/215/TC	AW250/102	17.604	1,793	9.55	7,086	7.64	7,086	5.73	7,086
11.52	7,086	C502_0175	MR300/210	213/215/TC	AW300/110	17.604	1,793	9.55	7,086	7.64	7,086	5.73	7,086
18.72	11,515	C612_0175	MR200/180	182/184/TC	AW200/014	17.600	2,411	15.51	11,515	12.41	11,515	9.31	11,515
18.72	11,515	C612_0175	MR250/180	182/184/TC	AW250/102	17.600	2,411	15.51	11,515	12.41	11,515	9.31	11,515
18.72	11,515	C612_0175	MR300/280	284/286TC	AW300/110	17.600	2,411	15.51	11,515	12.41	11,515	9.31	11,515
34.84	21,046	C812_0175	MR250/180	182/184/TC	AW250/102	17.287	4,500	28.87	21,046	23.10	21,046	17.32	21,046
52.79	31,889	C812_0175	MR300/280	284/286TC	AW300/110	17.287	4,500	43.74	31,889	34.99	31,889	26.25	31,889
52.79	31,889	C812_0175	MR350/320	324/326TC	AW350/202	17.287	4,500	43.74	31,889	34.99	31,889	26.25	31,889
86.19*	53,148	C912_0175	MR350/320	324/326TC	AW350/202	17.648	5,579	71.41	53,148	57.13	53,148	42.85	53,148
<b>95 RPM Output (Approximate)</b>													
								<b>78 RPM</b>	<b>62 RPM</b>	<b>47 RPM</b>			
23.36	14,906	C712_0185	MR200/180	182/184/TC	AW200/014	18.261	3,346	19.36	14,906	15.48	14,906	11.61	14,906
27.76	17,716	C712_0185	MR300/280	284/286TC	AW300/110	18.261	3,346	23.01	17,716	18.40	17,716	13.80	17,716
27.76	17,716	C712_0185	MR250/180	182/184/TC	AW250/102	18.261	3,346	23.01	17,716	18.40	17,716	13.80	17,716
<b>90 RPM Output (Approximate)</b>													
								<b>75 RPM</b>	<b>60 RPM</b>	<b>45 RPM</b>			
15.96	10,934	C612_0195	MR200/180	182/184/TC	AW200/014	19.607	2,477	14.08	11,641	12.13	12,540	9.32	12,844
18.62	12,759	C612_0195	MR250/180	182/184/TC	AW250/102	19.607	2,477	15.53	12,844	12.43	12,844	9.32	12,844
18.62	12,759	C612_0195	MR300/250	254/256TC	AW300/110	19.607	2,477	15.53	12,844	12.43	12,844	9.32	12,844
31.90	22,576	C812_0200	MR250/210	213/215/TC	AW250/102	20.257	4,682	26.43	22,576	21.14	22,576	15.86	22,576
49.00	34,684	C812_0200	MR300/250	254/256TC	AW300/110	20.257	4,682	43.23	36,928	34.84	37,204	26.13	37,204
49.00	34,684	C812_0200	MR350/320	324/326TC	AW350/202	20.257	4,682	43.23	36,928	34.84	37,204	26.13	37,204
63.19	44,494	C912_0200	MR300/250	254/256TC	AW300/110	20.152	5,767	52.36	44,494	41.89	44,494	31.41	44,494
88.06*	62,006	C912_0200	MR350/360	364/365TC	AW350/202	20.152	5,767	72.96	62,006	58.37	62,006	43.78	62,006
<b>85 RPM Output (Approximate) Continued Next Page</b>													
								<b>70 RPM</b>	<b>55 RPM</b>	<b>40 RPM</b>			
0.73	531	C002_0210	MR140/050	56C	AW140/010	20.714	298	0.61	531	0.49	531	0.37	531
0.73	531	C002_0210	MR160/050	56C	AW160/012	20.714	298	0.61	531	0.49	531	0.37	531
1.46	1,063	C102_0210	MR140/050	56C	AW140/010	20.844	424	1.21	1,063	0.97	1,063	0.73	1,063
1.46	1,063	C102_0210	MR160/050	56C	AW160/012	20.844	424	1.21	1,063	0.97	1,063	0.73	1,063
1.46	1,063	C102_0210	MR160/140	143/145TC	AW160/012	20.844	424	1.21	1,063	0.97	1,063	0.73	1,063

### Part No. Explanation

**C 3 0 2 N 0620 AW 140 / 012**

Unit No.  
Concentric Helical

Generation No.  
No. of Gear Reductions

Housing Style  
Ratio (0620 = 62.0:1)

Input Shaft  
Shaft Dia. (1/16 in.; example- 012=12/16 or 3/4)

Flange No.

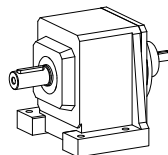

**C 3 0 2 N 0620 MR 160 / 140**

Unit No.  
Concentric Helical

Generation No.  
No. of Reductions

Housing Style  
Ratio (0620 = 62.0:1)

Motor Adapter  
Flange No.

Motor Frame Size (140=143/145TC)

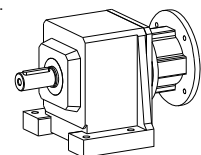

**Mounting position must be specified when ordering.**

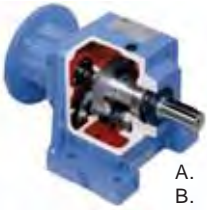

# "C" Series – Concentric Helical MGS Reducer – Selection Data



## Selection Procedure:

- Under the Input RPM heading, find **Approximate Output RPM** nearest the requirement.
- In the **Input HP** column locate the rating that is greater than or equal to the required HP.  
(If selection is based on Torque instead of HP, find an **Output Torque** that is equal to or greater than required.)
- When HP or Torque rating is located, read across that row to select the **Base Module**, **Input Option** and **Overhung Loads**.
- If exact **Output RPM** is required, divide the **Input RPM** by the **Exact Ratio**.

1750 RPM Input		Base Module <sup>1)</sup>	Input Options <sup>2)</sup>			Exact Ratio	Overhung Load Output Shaft <sup>3)</sup> lbs.	1450 RPM Input		1160 RPM Input		870 RPM Input	
Input HP	Output Torque in. lbs.		Motor Adapter	NEMA C-Frame Size <sup>4)</sup>	Input Shaft			Input HP	Output Torque in. lbs.	Input HP	Output Torque in. lbs.	Input HP	Output Torque in. lbs.
<b>85 RPM Output (Approximate) Continued</b>													
1.46	1,063	<b>C102_0210</b>	<b>MR200/180</b>	182/184/TC	<b>AW200/014</b>	20.844	424	1.21	1,063	0.97	1,063	0.73	1,063
2.29	1,650	<b>C202_0210</b>	<b>MR140/050</b>	56C	<b>AW140/010</b>	20.583	595	1.90	1,650	1.52	1,650	1.14	1,650
2.46	1,772	<b>C202_0210</b>	<b>MR160/050</b>	56C	<b>AW160/012</b>	20.583	595	2.04	1,772	1.63	1,772	1.22	1,772
2.46	1,772	<b>C202_0210</b>	<b>MR160/140</b>	143/145TC	<b>AW160/012</b>	20.583	595	2.04	1,772	1.63	1,772	1.22	1,772
2.46	1,772	<b>C202_0210</b>	<b>MR200/180</b>	182/184/TC	<b>AW200/014</b>	20.583	595	2.04	1,772	1.63	1,772	1.22	1,772
4.27	3,100	<b>C302_0210</b>	<b>MR160/050</b>	56C	<b>AW160/012</b>	20.800	888	3.53	3,100	2.83	3,100	2.12	3,100
4.27	3,100	<b>C302_0210</b>	<b>MR160/140</b>	143/145TC	<b>AW160/012</b>	20.800	888	3.53	3,100	2.83	3,100	2.12	3,100
4.27	3,100	<b>C302_0210</b>	<b>MR200/180</b>	182/184/TC	<b>AW200/014</b>	20.800	888	3.53	3,100	2.83	3,100	2.12	3,100
4.27	3,100	<b>C302_0210</b>	<b>MR250/180</b>	182/184/TC	<b>AW250/102</b>	20.800	888	3.53	3,100	2.83	3,100	2.12	3,100
6.67	4,872	<b>C402_0210</b>	<b>MR160/050</b>	56C	<b>AW160/012</b>	20.899	1,526	5.53	4,872	4.42	4,872	3.32	4,872
6.67	4,872	<b>C402_0210</b>	<b>MR160/140</b>	143/145TC	<b>AW160/012</b>	20.899	1,526	5.53	4,872	4.42	4,872	3.32	4,872
6.67	4,872	<b>C402_0210</b>	<b>MR200/180</b>	182/184/TC	<b>AW200/014</b>	20.899	1,526	5.53	4,872	4.42	4,872	3.32	4,872
6.67	4,872	<b>C402_0210</b>	<b>MR250/180</b>	182/184/TC	<b>AW250/102</b>	20.899	1,526	5.53	4,872	4.42	4,872	3.32	4,872
9.69	7,061	<b>C502_0210</b>	<b>MR160/050</b>	56C	<b>AW160/012</b>	20.844	1,871	8.06	7,086	6.45	7,086	4.84	7,086
9.69	7,061	<b>C502_0210</b>	<b>MR160/140</b>	143/145TC	<b>AW160/012</b>	20.844	1,871	8.06	7,086	6.45	7,086	4.84	7,086
9.69	7,061	<b>C502_0210</b>	<b>MR200/180</b>	182/184/TC	<b>AW200/014</b>	20.844	1,871	8.06	7,086	6.45	7,086	4.84	7,086
9.69	7,061	<b>C502_0210</b>	<b>MR250/180</b>	182/184/TC	<b>AW250/102</b>	20.844	1,871	8.06	7,086	6.45	7,086	4.84	7,086
9.73	7,086	<b>C502_0210</b>	<b>MR300/280</b>	284/286TC	<b>AW300/110</b>	20.844	1,871	8.06	7,086	6.45	7,086	4.84	7,086
18.57	13,413	<b>C712_0210</b>	<b>MR200/180</b>	182/184/TC	<b>AW200/014</b>	20.672	3,451	16.38	14,281	14.12	15,384	11.61	16,874
29.43	21,259	<b>C712_0210</b>	<b>MR250/180</b>	182/184/TC	<b>AW250/102</b>	20.672	3,451	24.39	21,259	19.51	21,259	14.63	21,259
29.43	21,259	<b>C712_0210</b>	<b>MR300/280</b>	284/286TC	<b>AW300/110</b>	20.672	3,451	24.39	21,259	19.51	21,259	14.63	21,259

<b>75 RPM Output (Approximate) Continued Next Page</b>													
<b>60 RPM</b>													
<b>50 RPM</b>													
<b>37 ORPM</b>													
0.66	531	<b>C002_0230</b>	<b>MR140/050</b>	56C	<b>AW140/010</b>	23.214	307	0.54	531	0.43	531	0.33	531
0.66	531	<b>C002_0230</b>	<b>MR160/050</b>	56C	<b>AW160/012</b>	23.214	307	0.54	531	0.43	531	0.33	531
1.29	1,063	<b>C102_0240</b>	<b>MR140/050</b>	56C	<b>AW140/010</b>	23.523	437	1.07	1,063	0.86	1,063	0.64	1,063
1.29	1,063	<b>C102_0240</b>	<b>MR160/050</b>	56C	<b>AW160/012</b>	23.523	437	1.07	1,063	0.86	1,063	0.64	1,063
1.29	1,063	<b>C102_0240</b>	<b>MR160/140</b>	143/145TC	<b>AW160/012</b>	23.523	437	1.07	1,063	0.86	1,063	0.64	1,063
1.29	1,063	<b>C102_0240</b>	<b>MR200/180</b>	182/184/TC	<b>AW200/014</b>	23.523	437	1.07	1,063	0.86	1,063	0.64	1,063
2.15	1,772	<b>C202_0240</b>	<b>MR140/050</b>	56C	<b>AW140/010</b>	23.593	616	1.78	1,772	1.42	1,772	1.07	1,772
2.15	1,772	<b>C202_0240</b>	<b>MR160/050</b>	56C	<b>AW160/012</b>	23.593	616	1.78	1,772	1.42	1,772	1.07	1,772
2.15	1,772	<b>C202_0240</b>	<b>MR160/140</b>	143/145TC	<b>AW160/012</b>	23.593	616	1.78	1,772	1.42	1,772	1.07	1,772
2.15	1,772	<b>C202_0240</b>	<b>MR200/180</b>	182/184/TC	<b>AW200/014</b>	23.593	616	1.78	1,772	1.42	1,772	1.07	1,772
3.78	3,100	<b>C302_0230</b>	<b>MR160/050</b>	56C	<b>AW160/012</b>	23.472	915	3.13	3,100	2.51	3,100	1.88	3,100
3.78	3,100	<b>C302_0230</b>	<b>MR160/140</b>	143/145TC	<b>AW160/012</b>	23.472	915	3.13	3,100	2.51	3,100	1.88	3,100
3.78	3,100	<b>C302_0230</b>	<b>MR200/180</b>	182/184/TC	<b>AW200/014</b>	23.472	915	3.13	3,100	2.51	3,100	1.88	3,100
3.78	3,100	<b>C302_0230</b>	<b>MR250/210</b>	213/215/TC	<b>AW250/102</b>	23.472	915	3.13	3,100	2.51	3,100	1.88	3,100
5.97	4,872	<b>C402_0230</b>	<b>MR160/050</b>	56C	<b>AW160/012</b>	23.359	1,569	4.95	4,872	3.96	4,872	2.97	4,872
5.97	4,872	<b>C402_0230</b>	<b>MR160/140</b>	143/145TC	<b>AW160/012</b>	23.359	1,569	4.95	4,872	3.96	4,872	2.97	4,872
5.97	4,872	<b>C402_0230</b>	<b>MR200/180</b>	182/184/TC	<b>AW200/014</b>	23.359	1,569	4.95	4,872	3.96	4,872	2.97	4,872

\* For thermal HP capacity, see rating below.

Base Module	C0	C1	C2	C3	C4	C5	C6	C7	C8	C9
Thermal Capacity	2.95	5.36	7.38	12.34	14.75	20.12	29.50	40.23	53.64	67.05

NEMA Frame Size  
TEFC 1750 RPM

C-Frame	Motor HP
56C	1/3 - 1 1/2
143/145TC	1, 1 1/2, 2
182/184TC	3, 5
213/215TC	7 1/2, 10
254/256TC	15, 20
284/286TC	25, 30
324/326TC	40, 50
364/365TC	60, 75

## Housing Styles

**N** – Foot Mounted    **F** – Round Flange    **Q** – Square Flange    **G** – Tapped Holes

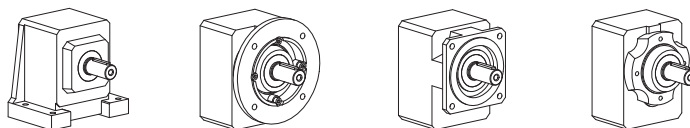

Housing Style Q is available on special order.



# "C" Series – Concentric Helical MGS Reducer – Selection Data



- NOTE:** 1) Complete Base Module Part Number by adding Housing Style. Example: C302N0560.  
 2) Select Input Option and add to completed Part Number. See example below.  
 3) Overhung Load is measured at the center of the shaft extension. Hollow output units are not intended to support overhung loads. If a load rating is required, use 50% of the published overhung load.  
 4) Other frame sizes may also be available. See dimension pages.

1750 RPM Input		Base Module <sup>1)</sup>	Input Options <sup>2)</sup>			Exact Ratio	Overhung Load Output Shaft <sup>3)</sup> lbs.	1450 RPM Input		1160 RPM Input		870 RPM Input	
Input HP	Output Torque in. lbs.		Motor Adapter	NEMA C-Frame Size <sup>4)</sup>	Input Shaft			Input HP	Output Torque in. lbs.	Input HP	Output Torque in. lbs.	Input HP	Output Torque in. lbs.
<b>75 RPM Output (Approximate) Continued</b>													
5.97	4,872	C402_0230	MR250/180	182/184/TC	AW250/102	23.359	1,569	4.95	4,872	3.96	4,872	2.97	4,872
8.68	7,086	C502_0230	MR160/050	56C	AW160/012	23.359	1,925	7.19	7,086	5.76	7,086	4.32	7,086
8.68	7,086	C502_0230	MR160/140	143/145TC	AW160/012	23.359	1,925	7.19	7,086	5.76	7,086	4.32	7,086
8.68	7,086	C502_0230	MR200/180	182/184/TC	AW200/014	23.359	1,925	7.19	7,086	5.76	7,086	4.32	7,086
8.68	7,086	C502_0230	MR250/210	213/215/TC	AW250/102	23.359	1,925	7.19	7,086	5.76	7,086	4.32	7,086
8.68	7,086	C502_0230	MR300/280	284/286TC	AW300/110	23.359	1,925	7.19	7,086	5.76	7,086	4.32	7,086
14.54	11,515	C612_0230	MR200/180	182/184/TC	AW200/014	22.667	2,568	12.05	11,515	9.64	11,515	7.23	11,515
14.54	11,515	C612_0230	MR250/180	182/184/TC	AW250/102	22.667	2,568	12.05	11,515	9.64	11,515	7.23	11,515
14.54	11,515	C612_0230	MR300/210	213/215/TC	AW300/110	22.667	2,568	12.05	11,515	9.64	11,515	7.23	11,515
21.87	17,716	C712_0230	MR200/180	182/184/TC	AW200/014	23.182	3,551	18.12	17,716	14.50	17,716	10.87	17,716
21.87	17,716	C712_0230	MR250/180	182/184/TC	AW250/102	23.182	3,551	18.12	17,716	14.50	17,716	10.87	17,716
21.87	17,716	C712_0230	MR300/280	284/286TC	AW300/110	23.182	3,551	18.12	17,716	14.50	17,716	10.87	17,716
32.99	26,733	C812_0230	MR250/180	182/184/TC	AW250/102	23.188	4,843	27.34	26,733	21.87	26,733	16.40	26,733
39.36	31,889	C812_0230	MR300/250	254/256TC	AW300/110	23.188	4,843	32.61	31,889	26.09	31,889	19.57	31,889
39.36	31,889	C812_0230	MR350/320	324/326TC	AW350/202	23.188	4,843	32.61	31,889	26.09	31,889	19.57	31,889
65.03	53,148	C912_0230	MR300/180	182/184/TC	AW300/110	23.390	5,986	53.88	53,148	43.11	53,148	32.33	53,148
65.03	53,148	C912_0230	MR350/320	324/326TC	AW350/202	23.390	5,986	53.88	53,148	43.11	53,148	32.33	53,148
<b>70 RPM Output (Approximate) Continued Next Page</b>													
0.61	531	C002_0250	MR140/050	56C	AW140/010	24.972	312	0.50	531	0.40	531	0.30	531
0.61	531	C002_0250	MR160/050	56C	AW160/012	24.972	312	0.50	531	0.40	531	0.30	531
1.21	1,063	C102_0250	MR140/050	56C	AW140/010	25.133	445	1.00	1,063	0.80	1,063	0.60	1,063
1.21	1,063	C102_0250	MR160/050	56C	AW160/012	25.133	445	1.00	1,063	0.80	1,063	0.60	1,063
1.21	1,063	C102_0250	MR160/140	143/145TC	AW160/012	25.133	445	1.00	1,063	0.80	1,063	0.60	1,063
2.06	1,772	C202_0250	MR140/050	56C	AW140/010	24.641	623	1.70	1,772	1.36	1,772	1.02	1,772
2.06	1,772	C202_0250	MR160/050	56C	AW160/012	24.641	623	1.70	1,772	1.36	1,772	1.02	1,772
2.06	1,772	C202_0250	MR160/140	143/145TC	AW160/012	24.641	623	1.70	1,772	1.36	1,772	1.02	1,772
2.06	1,772	C202_0250	MR200/180	182/184/TC	AW200/014	24.641	623	1.70	1,772	1.36	1,772	1.02	1,772
3.58	3,100	C302_0250	MR160/050	56C	AW160/012	24.800	928	2.96	3,100	2.37	3,100	1.78	3,100
3.58	3,100	C302_0250	MR160/140	143/145TC	AW160/012	24.800	928	2.96	3,100	2.37	3,100	1.78	3,100
3.58	3,100	C302_0250	MR200/180	182/184/TC	AW200/014	24.800	928	2.96	3,100	2.37	3,100	1.78	3,100
3.58	3,100	C302_0250	MR250/210	213/215/TC	AW250/102	24.800	928	2.96	3,100	2.37	3,100	1.78	3,100
5.59	4,872	C402_0250	MR160/050	56C	AW160/012	24.923	1,594	4.64	4,872	3.71	4,872	2.78	4,872
5.59	4,872	C402_0250	MR160/140	143/145TC	AW160/012	24.923	1,594	4.64	4,872	3.71	4,872	2.78	4,872
5.59	4,872	C402_0250	MR200/180	182/184/TC	AW200/014	24.923	1,594	4.64	4,872	3.71	4,872	2.78	4,872
5.59	4,872	C402_0250	MR250/180	182/184/TC	AW250/102	24.923	1,594	4.64	4,872	3.71	4,872	2.78	4,872
8.09	7,086	C502_0250	MR160/050	56C	AW160/012	25.073	1,959	6.70	7,086	5.36	7,086	4.02	7,086
8.09	7,086	C502_0250	MR160/140	143/145TC	AW160/012	25.073	1,959	6.70	7,086	5.36	7,086	4.02	7,086
8.09	7,086	C502_0250	MR200/180	182/184/TC	AW200/014	25.073	1,959	6.70	7,086	5.36	7,086	4.02	7,086

### Part No. Explanation

**C 3 0 2 N 0620 AW 140 /012**

Unit No.  
 Concentric Helical  
 Generation No.  
 No. of Gear Reductions  
 Housing Style  
 Ratio (0620 = 62.0:1)  
 Input Shaft  
 Flange No.  
 Shaft Dia. (1/16 in.; example- 012=12/16 or 3/4)

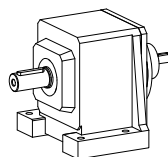

**C 3 0 2 N 0620 MR 160 /140**

Unit No.  
 Concentric Helical  
 Generation No.  
 No. of Reductions  
 Housing Style  
 Ratio (0620 = 62.0:1)  
 Motor Adapter  
 Flange No.  
 Motor Frame Size (140=143/145TC)

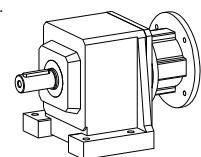

**Mounting position must be specified when ordering.**



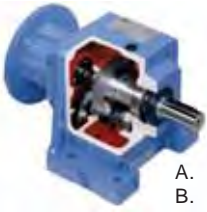

# "C" Series – Concentric Helical MGS Reducer – Selection Data



### Selection Procedure:

- Under the Input RPM heading, find **Approximate Output RPM** nearest the requirement.
- In the **Input HP** column locate the rating that is greater than or equal to the required HP.  
(If selection is based on Torque instead of HP, find an **Output Torque** that is equal to or greater than required.)
- When HP or Torque rating is located, read across that row to select the **Base Module**, **Input Option** and **Overhung Loads**.
- If exact **Output RPM** is required, divide the **Input RPM** by the **Exact Ratio**.

1750 RPM Input		Base Module <sup>1)</sup>	Input Options <sup>2)</sup>			Exact Ratio	Overhung Load Output Shaft <sup>3)</sup> lbs.	1450 RPM Input		1160 RPM Input		870 RPM Input	
Input HP	Output Torque in. lbs.		Motor Adapter	NEMA C-Frame Size <sup>4)</sup>	Input Shaft			Input HP	Output Torque in. lbs.	Input HP	Output Torque in. lbs.	Input HP	Output Torque in. lbs.
<b>70 RPM Output (Approximate) Continued</b>													
8.09	7,086	<b>C502_0250</b>	<b>MR250/210</b>	213/215/TC	<b>AW250/102</b>	25.073	1,959	6.70	7,086	5.36	7,086	4.02	7,086
8.09	7,086	<b>C502_0250</b>	<b>MR300/250</b>	254/256TC	<b>AW300/110</b>	25.073	1,959	6.70	7,086	5.36	7,086	4.02	7,086
13.15	11,454	<b>C612_0250</b>	<b>MR200/180</b>	182/184/TC	<b>AW200/014</b>	24.928	2,630	11.60	12,195	9.77	12,844	7.33	12,844
14.75	12,844	<b>C612_0250</b>	<b>MR250/210</b>	213/215/TC	<b>AW250/102</b>	24.928	2,630	12.22	12,844	9.77	12,844	7.33	12,844
14.75	12,844	<b>C612_0250</b>	<b>MR300/280</b>	284/286TC	<b>AW300/110</b>	24.928	2,630	12.22	12,844	9.77	12,844	7.33	12,844
15.96	14,116	<b>C712_0250</b>	<b>MR200/180</b>	182/184/TC	<b>AW200/014</b>	25.313	3,630	14.08	15,029	12.13	16,190	10.02	17,819
24.04	21,259	<b>C712_0250</b>	<b>MR250/180</b>	182/184/TC	<b>AW250/102</b>	25.313	3,630	19.92	21,259	15.93	21,259	11.95	21,259
24.04	21,259	<b>C712_0250</b>	<b>MR300/280</b>	284/286TC	<b>AW300/110</b>	25.313	3,630	19.92	21,259	15.93	21,259	11.95	21,259
60.27	53,368	<b>C912_0250</b>	<b>MR300/250</b>	254/256TC	<b>AW300/110</b>	25.342	6,107	49.94	53,368	39.95	53,368	29.96	53,368
70.02*	62,006	<b>C912_0250</b>	<b>MR350/360</b>	364/365TC	<b>AW350/202</b>	25.342	6,107	58.02	62,006	46.42	62,006	34.81	62,006
<b>65 RPM Output (Approximate)</b>													
12.01	11,515	<b>C612_0270</b>	<b>MR200/180</b>	182/184/TC	<b>AW200/014</b>	27.429	2,694	9.96	11,515	7.96	11,515	5.97	11,515
12.01	11,515	<b>C612_0270</b>	<b>MR250/180</b>	182/184/TC	<b>AW250/102</b>	27.429	2,694	9.96	11,515	7.96	11,515	5.97	11,515
12.01	11,515	<b>C612_0270</b>	<b>MR300/280</b>	284/286TC	<b>AW300/110</b>	27.429	2,694	9.96	11,515	7.96	11,515	5.97	11,515
30.29	27,576	<b>C812_0260</b>	<b>MR250/210</b>	213/215/TC	<b>AW250/102</b>	26.058	4,986	25.09	27,576	20.08	27,576	15.06	27,576
31.90	30,612	<b>C812_0270</b>	<b>MR250/210</b>	213/215/TC	<b>AW250/102</b>	27.467	5,052	26.43	30,612	21.14	30,612	15.86	30,612
33.23	31,889	<b>C812_0270</b>	<b>MR300/250</b>	254/256TC	<b>AW300/110</b>	27.467	5,052	27.53	31,889	22.02	31,889	16.52	31,889
33.23	31,889	<b>C812_0270</b>	<b>MR350/320</b>	324/326TC	<b>AW350/202</b>	27.467	5,052	27.53	31,889	22.02	31,889	16.52	31,889
40.86	37,204	<b>C812_0260</b>	<b>MR300/180</b>	182/184/TC	<b>AW300/110</b>	26.058	4,986	33.86	37,204	27.08	37,204	20.31	37,204
<b>60 RPM Output (Approximate) Continued Next Page</b>													
0.54	531	<b>C002_0280</b>	<b>MR140/050</b>	56C	<b>AW140/010</b>	27.986	321	0.45	531	0.36	531	0.27	531
0.54	531	<b>C002_0280</b>	<b>MR160/050</b>	56C	<b>AW160/012</b>	27.986	321	0.45	531	0.36	531	0.27	531
1.07	1,063	<b>C102_0280</b>	<b>MR140/050</b>	56C	<b>AW140/010</b>	28.364	458	0.89	1,063	0.71	1,063	0.53	1,063
1.07	1,063	<b>C102_0280</b>	<b>MR160/050</b>	56C	<b>AW160/012</b>	28.364	458	0.89	1,063	0.71	1,063	0.53	1,063
1.07	1,063	<b>C102_0280</b>	<b>MR160/140</b>	143/145TC	<b>AW160/012</b>	28.364	458	0.89	1,063	0.71	1,063	0.53	1,063
1.80	1,772	<b>C202_0280</b>	<b>MR140/050</b>	56C	<b>AW140/010</b>	28.243	644	1.49	1,772	1.19	1,772	0.89	1,772
1.80	1,772	<b>C202_0280</b>	<b>MR160/050</b>	56C	<b>AW160/012</b>	28.243	644	1.49	1,772	1.19	1,772	0.89	1,772
1.80	1,772	<b>C202_0280</b>	<b>MR160/140</b>	143/145TC	<b>AW160/012</b>	28.243	644	1.49	1,772	1.19	1,772	0.89	1,772
1.80	1,772	<b>C202_0280</b>	<b>MR200/180</b>	182/184/TC	<b>AW200/014</b>	28.243	644	1.49	1,772	1.19	1,772	0.89	1,772
3.17	3,100	<b>C302_0280</b>	<b>MR160/050</b>	56C	<b>AW160/012</b>	27.986	956	2.63	3,100	2.10	3,100	1.58	3,100
3.17	3,100	<b>C302_0280</b>	<b>MR160/140</b>	143/145TC	<b>AW160/012</b>	27.986	956	2.63	3,100	2.10	3,100	1.58	3,100
3.17	3,100	<b>C302_0280</b>	<b>MR200/180</b>	182/184/TC	<b>AW200/014</b>	27.986	956	2.63	3,100	2.10	3,100	1.58	3,100
3.17	3,100	<b>C302_0280</b>	<b>MR250/180</b>	182/184/TC	<b>AW250/102</b>	27.986	956	2.63	3,100	2.10	3,100	1.58	3,100
5.01	4,872	<b>C402_0280</b>	<b>MR160/050</b>	56C	<b>AW160/012</b>	27.857	1,639	4.15	4,872	3.32	4,872	2.49	4,872
5.01	4,872	<b>C402_0280</b>	<b>MR160/140</b>	143/145TC	<b>AW160/012</b>	27.857	1,639	4.15	4,872	3.32	4,872	2.49	4,872
5.01	4,872	<b>C402_0280</b>	<b>MR200/180</b>	182/184/TC	<b>AW200/014</b>	27.857	1,639	4.15	4,872	3.32	4,872	2.49	4,872
5.01	4,872	<b>C402_0280</b>	<b>MR250/210</b>	213/215/TC	<b>AW250/102</b>	27.857	1,639	4.15	4,872	3.32	4,872	2.49	4,872

\* For thermal HP capacity, see rating below.

Base Module	C0	C1	C2	C3	C4	C5	C6	C7	C8	C9
Thermal Capacity	2.95	5.36	7.38	12.34	14.75	20.12	29.50	40.23	53.64	67.05

### NEMA Frame Size TEFC 1750 RPM

C-Frame	Motor HP
56C	1/3 - 1 1/2
143/145TC	1, 1 1/2, 2
182/184TC	3, 5
213/215TC	7 1/2, 10
254/256TC	15, 20
284/286TC	25, 30
324/326TC	40, 50
364/365TC	60, 75

### Housing Styles

N – Foot Mounted    F – Round Flange    Q – Square Flange    G – Tapped Holes

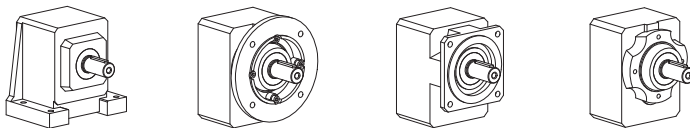

Housing Style Q is available on special order.



# "C" Series – Concentric Helical MGS Reducer – Selection Data



- NOTE:** 1) Complete Base Module Part Number by adding Housing Style. Example: C302N0620.  
 2) Select Input Option and add to completed Part Number. See example below.  
 3) Overhung Load is measured at the center of the shaft extension. Hollow output units are not intended to support overhung loads. If a load rating is required, use 50% of the published overhung load.  
 4) Other frame sizes may also be available. See dimension pages.

1750 RPM Input		Base Module <sup>1)</sup>	Input Options <sup>2)</sup>			Exact Ratio	Overhung Load Output Shaft <sup>3)</sup> lbs.	1450 RPM Input		1160 RPM Input		870 RPM Input	
Input HP	Output Torque in. lbs.		Motor Adapter	NEMA C-Frame Size <sup>4)</sup>	Input Shaft			Input HP	Output Torque in. lbs.	Input HP	Output Torque in. lbs.	Input HP	Output Torque in. lbs.
<b>60 RPM Output (Approximate) Continued</b>													
7.22	7,086	C502_0280	MR160/050	56C	AW160/012	28.099	2,016	5.98	7,086	4.78	7,086	3.59	7,086
7.22	7,086	C502_0280	MR160/140	143/145TC	AW160/012	28.099	2,016	5.98	7,086	4.78	7,086	3.59	7,086
7.22	7,086	C502_0280	MR200/180	182/184/TC	AW200/014	28.099	2,016	5.98	7,086	4.78	7,086	3.59	7,086
7.22	7,086	C502_0280	MR250/180	182/184/TC	AW250/102	28.099	2,016	5.98	7,086	4.78	7,086	3.59	7,086
7.22	7,086	C502_0280	MR300/250	254/256TC	AW300/110	28.099	2,016	5.98	7,086	4.78	7,086	3.59	7,086
17.71	17,716	C712_0290	MR200/180	182/184/TC	AW200/014	28.636	3,744	14.67	17,716	11.74	17,716	8.80	17,716
17.71	17,716	C712_0290	MR250/210	213/215/TC	AW250/102	28.636	3,744	14.67	17,716	11.74	17,716	8.80	17,716
17.71	17,716	C712_0290	MR300/250	254/256TC	AW300/110	28.636	3,744	14.67	17,716	11.74	17,716	8.80	17,716
53.13	53,148	C912_0290	MR300/280	284/286TC	AW300/110	28.631	6,296	44.02	53,148	35.22	53,148	26.41	53,148
53.13	53,148	C912_0290	MR350/360	364/365TC	AW350/202	28.631	6,296	44.02	53,148	35.22	53,148	26.41	53,148
<b>55 RPM Output (Approximate)</b>													
0.49	531	C002_0310	MR140/050	56C	AW140/010	31.256	330	0.40	531	0.32	531	0.24	531
0.49	531	C002_0310	MR160/050	143/145TC	AW160/012	31.256	330	0.40	531	0.32	531	0.24	531
0.98	1,063	C102_0310	MR140/050	56C	AW140/010	31.071	469	0.81	1,063	0.65	1,063	0.49	1,063
0.98	1,063	C102_0310	MR160/050	56C	AW160/012	31.071	469	0.81	1,063	0.65	1,063	0.49	1,063
1.65	1,772	C202_0310	MR140/050	56C	AW140/010	30.692	658	1.37	1,772	1.10	1,772	0.82	1,772
1.65	1,772	C202_0310	MR160/050	56C	AW160/012	30.692	658	1.37	1,772	1.10	1,772	0.82	1,772
1.65	1,772	C202_0310	MR160/140	143/145TC	AW160/012	30.692	658	1.37	1,772	1.10	1,772	0.82	1,772
2.86	3,100	C302_0310	MR160/050	56C	AW160/012	31.040	981	2.37	3,100	1.89	3,100	1.42	3,100
2.86	3,100	C302_0310	MR160/140	143/145TC	AW160/012	31.040	981	2.37	3,100	1.89	3,100	1.42	3,100
2.86	3,100	C302_0310	MR200/180	182/184/TC	AW200/014	31.040	981	2.37	3,100	1.89	3,100	1.42	3,100
2.86	3,100	C302_0310	MR250/180	182/184/TC	AW250/102	31.040	981	2.37	3,100	1.89	3,100	1.42	3,100
4.48	4,872	C402_0310	MR160/050	56C	AW160/012	31.154	1,686	3.71	4,872	2.97	4,872	2.22	4,872
4.48	4,872	C402_0310	MR160/140	143/145TC	AW160/012	31.154	1,686	3.71	4,872	2.97	4,872	2.22	4,872
4.48	4,872	C402_0310	MR200/180	182/184/TC	AW200/014	31.154	1,686	3.71	4,872	2.97	4,872	2.22	4,872
4.48	4,872	C402_0310	MR250/210	213/215/TC	AW250/102	31.154	1,686	3.71	4,872	2.97	4,872	2.22	4,872
6.49	7,086	C502_0310	MR160/050	56C	AW160/012	31.231	2,070	5.38	7,086	4.30	7,086	3.23	7,086
6.49	7,086	C502_0310	MR160/140	143/145TC	AW160/012	31.231	2,070	5.38	7,086	4.30	7,086	3.23	7,086
6.49	7,086	C502_0310	MR200/180	182/184/TC	AW200/014	31.231	2,070	5.38	7,086	4.30	7,086	3.23	7,086
6.49	7,086	C502_0310	MR250/210	213/215/TC	AW250/102	31.231	2,070	5.38	7,086	4.30	7,086	3.23	7,086
10.61	12,011	C612_0320	MR200/180	182/184/TC	AW200/014	32.406	2,808	9.36	12,788	7.52	12,844	5.64	12,844
11.34	12,844	C612_0320	MR250/210	213/215/TC	AW250/102	32.406	2,808	9.40	12,844	7.52	12,844	5.64	12,844
11.34	12,844	C612_0320	MR300/210	213/215/TC	AW300/110	32.406	2,808	9.40	12,844	7.52	12,844	5.64	12,844
54.75	61,477	C912_0320	MR300/210	213/215/TC	AW300/110	32.134	6,481	45.76	62,006	36.61	62,006	27.45	62,006
55.22	62,006	C912_0320	MR350/360	364/365TC	AW350/202	32.134	6,481	45.76	62,006	36.61	62,006	27.45	62,006

### Part No. Explanation

C 3 0 2 N 0620 AW 140 / 012

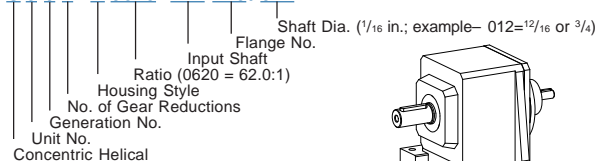

C 3 0 2 N 0620 MR 160 / 140

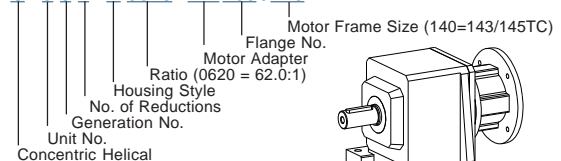

**Mounting position must be specified when ordering.**



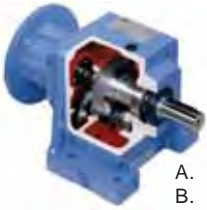

# "C" Series – Concentric Helical MGS Reducer – Selection Data



## Selection Procedure:

- Under the Input RPM heading, find **Approximate Output RPM** nearest the requirement.
- In the **Input HP** column locate the rating that is greater than or equal to the required HP.  
(If selection is based on Torque instead of HP, find an **Output Torque** that is equal to or greater than required.)
- When HP or Torque rating is located, read across that row to select the **Base Module**, **Input Option** and **Overhung Loads**.
- If exact **Output RPM** is required, divide the **Input RPM** by the **Exact Ratio**.

1750 RPM Input		Base Module <sup>1)</sup>	Input Options <sup>2)</sup>			Exact Ratio	Overhung Load Output Shaft <sup>3)</sup> lbs.	1450 RPM Input		1160 RPM Input		870 RPM Input	
Input HP	Output Torque in. lbs.		Motor Adapter	NEMA C-Frame Size <sup>4)</sup>	Input Shaft			Input HP	Output Torque in. lbs.	Input HP	Output Torque in. lbs.	Input HP	Output Torque in. lbs.
<b>50 RPM Output (Approximate)</b>													
0.43	531	<b>C002_0350</b>	<b>MR140/050</b>	56C	<b>AW140/010</b>	35.028	340	0.36	531	0.29	531	0.22	531
0.43	531	<b>C002_0350</b>	<b>MR160/050</b>	143/145TC	<b>AW160/012</b>	35.028	340	0.36	531	0.29	531	0.22	531
0.87	1,063	<b>C102_0350</b>	<b>MR140/050</b>	56C	<b>AW140/010</b>	35.065	483	0.72	1,063	0.58	1,063	0.43	1,063
0.87	1,063	<b>C102_0350</b>	<b>MR160/050</b>	56C	<b>AW160/012</b>	35.065	483	0.72	1,063	0.58	1,063	0.43	1,063
1.44	1,772	<b>C202_0350</b>	<b>MR140/050</b>	56C	<b>AW140/010</b>	35.179	681	1.19	1,772	0.96	1,772	0.72	1,772
1.44	1,772	<b>C202_0350</b>	<b>MR160/050</b>	56C	<b>AW160/012</b>	35.179	681	1.19	1,772	0.96	1,772	0.72	1,772
1.44	1,772	<b>C202_0350</b>	<b>MR160/140</b>	143/145TC	<b>AW160/012</b>	35.179	681	1.19	1,772	0.96	1,772	0.72	1,772
2.53	3,100	<b>C302_0350</b>	<b>MR160/050</b>	56C	<b>AW160/012</b>	35.028	1,011	2.10	3,100	1.68	3,100	1.26	3,100
2.53	3,100	<b>C302_0350</b>	<b>MR160/140</b>	143/145TC	<b>AW160/012</b>	35.028	1,011	2.10	3,100	1.68	3,100	1.26	3,100
4.00	4,872	<b>C402_0350</b>	<b>MR160/050</b>	56C	<b>AW160/012</b>	34.821	1,733	3.32	4,872	2.65	4,872	1.99	4,872
4.00	4,872	<b>C402_0350</b>	<b>MR160/140</b>	143/145TC	<b>AW160/012</b>	34.821	1,733	3.32	4,872	2.65	4,872	1.99	4,872
4.00	4,872	<b>C402_0350</b>	<b>MR200/180</b>	182/184TC	<b>AW200/014</b>	34.821	1,733	3.32	4,872	2.65	4,872	1.99	4,872
4.00	4,872	<b>C402_0350</b>	<b>MR250/210</b>	213/215TC	<b>AW250/102</b>	34.821	1,733	3.32	4,872	2.65	4,872	1.99	4,872
5.79	7,086	<b>C502_0350</b>	<b>MR160/050</b>	56C	<b>AW160/012</b>	35.000	2,129	4.80	7,086	3.84	7,086	2.88	7,086
5.79	7,086	<b>C502_0350</b>	<b>MR160/140</b>	143/145TC	<b>AW160/012</b>	35.000	2,129	4.80	7,086	3.84	7,086	2.88	7,086
5.79	7,086	<b>C502_0350</b>	<b>MR200/180</b>	182/184TC	<b>AW200/014</b>	35.000	2,129	4.80	7,086	3.84	7,086	2.88	7,086
5.79	7,086	<b>C502_0350</b>	<b>MR250/210</b>	213/215TC	<b>AW250/102</b>	35.000	2,129	4.80	7,086	3.84	7,086	2.88	7,086
9.45	11,515	<b>C612_0350</b>	<b>MR200/180</b>	182/184TC	<b>AW200/014</b>	34.872	2,860	7.83	11,515	6.26	11,515	4.70	11,515
9.45	11,515	<b>C612_0350</b>	<b>MR250/210</b>	213/215TC	<b>AW250/102</b>	34.872	2,860	7.83	11,515	6.26	11,515	4.70	11,515
9.45	11,515	<b>C612_0350</b>	<b>MR300/250</b>	254/256TC	<b>AW300/110</b>	34.872	2,860	7.83	11,515	6.26	11,515	4.70	11,515
12.55	14,816	<b>C712_0340</b>	<b>MR200/180</b>	182/184TC	<b>AW200/014</b>	33.797	3,902	11.07	15,775	9.54	16,993	7.87	18,703
14.46	17,716	<b>C712_0350</b>	<b>MR200/180</b>	182/184TC	<b>AW200/014</b>	35.065	3,938	11.98	17,716	9.58	17,716	7.19	17,716
14.46	17,716	<b>C712_0350</b>	<b>MR250/180</b>	182/184TC	<b>AW250/102</b>	35.065	3,938	11.98	17,716	9.58	17,716	7.19	17,716
14.46	17,716	<b>C712_0350</b>	<b>MR300/210</b>	213/215TC	<b>AW300/110</b>	35.065	3,938	11.98	17,716	9.58	17,716	7.19	17,716
18.00	21,259	<b>C712_0340</b>	<b>MR250/180</b>	182/184TC	<b>AW250/102</b>	33.797	3,902	14.92	21,259	11.93	21,259	8.95	21,259
18.00	21,259	<b>C712_0340</b>	<b>MR300/250</b>	254/256TC	<b>AW300/110</b>	33.797	3,902	14.92	21,259	11.93	21,259	8.95	21,259
25.83	31,889	<b>C812_0350</b>	<b>MR250/210</b>	213/215TC	<b>AW250/102</b>	35.333	5,381	21.40	31,889	17.12	31,889	12.84	31,889
25.83	31,889	<b>C812_0350</b>	<b>MR300/280</b>	284/286TC	<b>AW300/110</b>	35.333	5,381	21.40	31,889	17.12	31,889	12.84	31,889
26.75	31,386	<b>C812_0340</b>	<b>MR250/210</b>	213/215TC	<b>AW250/102</b>	33.585	5,313	23.59	33,417	19.11	33,839	14.34	33,839
31.70	37,204	<b>C812_0340</b>	<b>MR300/280</b>	284/286TC	<b>AW300/110</b>	33.585	5,313	26.27	37,204	21.01	37,204	15.76	37,204
42.24	53,148	<b>C912_0360</b>	<b>MR300/250</b>	254/256TC	<b>AW300/110</b>	36.005	6,668	35.00	53,148	28.00	53,148	21.00	53,148
42.24	53,148	<b>C912_0360</b>	<b>MR350/360</b>	364/365TC	<b>AW350/202</b>	36.005	6,668	35.00	53,148	28.00	53,148	21.00	53,148

<b>45 RPM Output (Approximate) Continued Next Page</b>													
<b>35 RPM      30 RPM      20 RPM</b>													
0.36	531	<b>C002_0420</b>	<b>MR140/050</b>	56C	<b>AW140/010</b>	41.774	355	0.30	531	0.24	531	0.18	531
0.73	1,063	<b>C102_0420</b>	<b>MR140/050</b>	56C	<b>AW140/010</b>	41.567	504	0.61	1,063	0.49	1,063	0.36	1,063
0.73	1,063	<b>C102_0420</b>	<b>MR160/050</b>	56C	<b>AW160/012</b>	41.567	504	0.61	1,063	0.49	1,063	0.36	1,063
1.24	1,772	<b>C202_0410</b>	<b>MR140/050</b>	56C	<b>AW140/010</b>	40.850	707	1.03	1,772	0.82	1,772	0.62	1,772
1.24	1,772	<b>C202_0410</b>	<b>MR160/050</b>	56C	<b>AW160/012</b>	40.850	707	1.03	1,772	0.82	1,772	0.62	1,772
1.24	1,772	<b>C202_0410</b>	<b>MR160/140</b>	143/145TC	<b>AW160/012</b>	40.850	707	1.03	1,772	0.82	1,772	0.62	1,772

\* For thermal HP capacity, see rating below.

Base Module	C0	C1	C2	C3	C4	C5	C6	C7	C8	C9
Thermal Capacity	2.95	5.36	7.38	12.34	14.75	20.12	29.50	40.23	53.64	67.05

NEMA Frame Size  
TEFC 1750 RPM

C-Frame	Motor HP
56C	1/3 - 1 1/2
143/145TC	1, 1 1/2, 2
182/184TC	3, 5
213/215TC	7 1/2, 10
254/256TC	15, 20
284/286TC	25, 30
324/326TC	40, 50
364/365TC	60, 75

## Housing Styles

**N** – Foot Mounted    **F** – Round Flange    **Q** – Square Flange    **G** – Tapped Holes

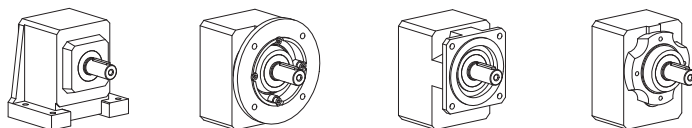

Housing Style Q is available on special order.



# "C" Series – Concentric Helical MGS Reducer – Selection Data



- NOTE:** 1) Complete Base Module Part Number by adding Housing Style. Example: C302N0560.  
 2) Select Input Option and add to completed Part Number. See example below.  
 3) Overhung Load is measured at the center of the shaft extension. Hollow output units are not intended to support overhung loads. If a load rating is required, use 50% of the published overhung load.  
 4) Other frame sizes may also be available. See dimension pages.

1750 RPM Input		Base Module <sup>1)</sup>	Input Options <sup>2)</sup>			Exact Ratio	Overhung Load Output Shaft <sup>3)</sup> lbs.	1450 RPM Input		1160 RPM Input		870 RPM Input	
Input HP	Output Torque in. lbs.		Motor Adapter	NEMA C-Frame Size <sup>4)</sup>	Input Shaft			Input HP	Output Torque in. lbs.	Input HP	Output Torque in. lbs.	Input HP	Output Torque in. lbs.
<b>45 RPM Output (Approximate) Continued</b>													
2.15	3,100	C302_0410	MR160/050	56C	AW160/012	41.354	1,054	1.78	3,100	1.42	3,100	1.07	3,100
2.15	3,100	C302_0410	MR160/140	143/145TC	AW160/012	41.354	1,054	1.78	3,100	1.42	3,100	1.07	3,100
3.34	4,872	C402_0420	MR160/050	56C	AW160/012	41.751	1,814	2.77	4,872	2.21	4,872	1.66	4,872
3.34	4,872	C402_0420	MR160/140	143/145TC	AW160/012	41.751	1,814	2.77	4,872	2.21	4,872	1.66	4,872
3.34	4,872	C402_0420	MR200/180	182/184/TC	AW200/014	41.751	1,814	2.77	4,872	2.21	4,872	1.66	4,872
3.34	4,872	C402_0420	MR250/210	213/215/TC	AW250/102	41.751	1,814	2.77	4,872	2.21	4,872	1.66	4,872
4.86	7,086	C502_0420	MR160/050	56C	AW160/012	41.688	2,224	4.03	7,086	3.22	7,086	2.42	7,086
4.86	7,086	C502_0420	MR160/140	143/145TC	AW160/012	41.688	2,224	4.03	7,086	3.22	7,086	2.42	7,086
4.86	7,086	C502_0420	MR200/180	182/184/TC	AW200/014	41.688	2,224	4.03	7,086	3.22	7,086	2.42	7,086
4.86	7,086	C502_0420	MR250/210	213/215/TC	AW250/102	41.688	2,224	4.03	7,086	3.22	7,086	2.42	7,086
7.85	10,812	C612_0390	MR200/180	182/184/TC	AW200/014	39.396	2,949	6.51	10,812	5.21	10,812	3.90	10,812
7.85	10,812	C612_0390	MR250/210	213/215/TC	AW250/102	39.396	2,949	6.51	10,812	5.21	10,812	3.90	10,812
10.61	15,202	C712_0410	MR200/180	182/184/TC	AW200/014	41.016	4,096	9.36	16,186	8.06	17,435	6.44	18,554
12.95	18,554	C712_0410	MR250/210	213/215/TC	AW250/102	41.016	4,096	10.73	18,554	8.58	18,554	6.44	18,554
12.95	18,554	C712_0410	MR300/210	213/215/TC	AW300/110	41.016	4,096	10.73	18,554	8.58	18,554	6.44	18,554
23.05	32,165	C812_0400	MR250/210	213/215/TC	AW250/102	39.938	5,548	19.91	33,527	15.92	33,527	11.94	33,527
24.02	33,527	C812_0400	MR300/210	213/215/TC	AW300/110	39.938	5,548	19.91	33,527	15.92	33,527	11.94	33,527
38.77	53,230	C912_0390	MR300/250	254/256TC	AW300/110	39.298	6,815	32.12	53,230	25.70	53,230	19.27	53,230

<b>40 RPM Output (Approximate) Continued Next Page</b>													
40 RPM		Output (Approximate)		Continued Next Page		30 RPM		25 RPM		19 RPM			
0.32	531	C002_0470	MR140/050	56C	AW140/010	46.815	366	0.27	531	0.22	531	0.16	531
0.65	1,063	C102_0470	MR140/050	56C	AW140/010	46.909	520	0.54	1,063	0.43	1,063	0.32	1,063
0.65	1,063	C102_0470	MR160/050	56C	AW160/012	46.909	520	0.54	1,063	0.43	1,063	0.32	1,063
1.08	1,772	C202_0470	MR140/050	56C	AW140/010	46.822	731	0.90	1,772	0.72	1,772	0.54	1,772
1.08	1,772	C202_0470	MR160/050	56C	AW160/012	46.822	731	0.90	1,772	0.72	1,772	0.54	1,772
1.08	1,772	C202_0470	MR160/140	143/145TC	AW160/012	46.822	731	0.90	1,772	0.72	1,772	0.54	1,772
1.90	3,100	C302_0470	MR160/050	56C	AW160/012	46.667	1,086	1.58	3,100	1.26	3,100	0.95	3,100
1.90	3,100	C302_0470	MR160/140	143/145TC	AW160/012	46.667	1,086	1.58	3,100	1.26	3,100	0.95	3,100
2.99	4,872	C402_0470	MR160/050	56C	AW160/012	46.667	1,865	2.48	4,872	1.98	4,872	1.49	4,872
2.99	4,872	C402_0470	MR160/140	143/145TC	AW160/012	46.667	1,865	2.48	4,872	1.98	4,872	1.49	4,872
4.34	7,086	C502_0470	MR160/050	56C	AW160/012	46.719	2,289	3.60	7,086	2.88	7,086	2.16	7,086
4.34	7,086	C502_0470	MR160/140	143/145TC	AW160/012	46.719	2,289	3.60	7,086	2.88	7,086	2.16	7,086
4.34	7,086	C502_0470	MR200/180	182/184/TC	AW200/014	46.719	2,289	3.60	7,086	2.88	7,086	2.16	7,086
4.34	7,086	C502_0470	MR250/210	213/215/TC	AW250/102	46.719	2,289	3.60	7,086	2.88	7,086	2.16	7,086
7.27	11,515	C612_0450	MR200/180	182/184/TC	AW200/014	45.333	3,054	6.02	11,515	4.82	11,515	3.61	11,515
7.27	11,515	C612_0450	MR250/180	182/184/TC	AW250/102	45.333	3,054	6.02	11,515	4.82	11,515	3.61	11,515
7.27	11,515	C612_0450	MR300/210	213/215/TC	AW300/110	45.333	3,054	6.02	11,515	4.82	11,515	3.61	11,515
10.83	17,716	C712_0470	MR200/180	182/184/TC	AW200/014	46.818	4,234	8.97	17,716	7.18	17,716	5.38	17,716
10.83	17,716	C712_0470	MR250/180	182/184/TC	AW250/102	46.818	4,234	8.97	17,716	7.18	17,716	5.38	17,716
10.83	17,716	C712_0470	MR300/210	213/215/TC	AW300/110	46.818	4,234	8.97	17,716	7.18	17,716	5.38	17,716

### Part No. Explanation

**C 3 0 2 N 0620 AW 140 / 012**

Unit No.  
Concentric Helical

Generation No.  
No. of Gear Reductions

Housing Style  
Ratio (0620 = 62.0:1)

Input Shaft  
Flange No.

Shaft Dia. (1/16 in.; example- 012=1/16 or 3/4)

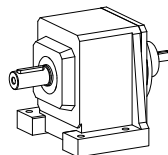

**C 3 0 2 N 0620 MR 160 / 140**

Unit No.  
Concentric Helical

Generation No.  
No. of Reductions

Housing Style  
Ratio (0620 = 62.0:1)

Motor Adapter  
Flange No.

Motor Frame Size (140=143/145TC)

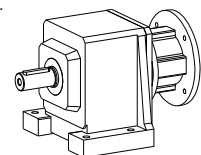

**Mounting position must be specified when ordering.**

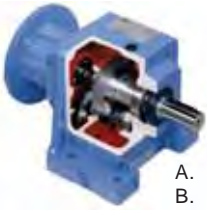

# "C" Series – Concentric Helical MGS Reducer – Selection Data



### Selection Procedure:

- Under the Input RPM heading, find **Approximate Output RPM** nearest the requirement.
- In the **Input HP** column locate the rating that is greater than or equal to the required HP.  
(If selection is based on Torque instead of HP, find an **Output Torque** that is equal to or greater than required.)
- When HP or Torque rating is located, read across that row to select the **Base Module**, **Input Option** and **Overhung Loads**.
- If exact **Output RPM** is required, divide the **Input RPM** by the **Exact Ratio**.

1750 RPM Input		Base Module <sup>1)</sup>	Input Options <sup>2)</sup>			Exact Ratio	Overhung Load Output Shaft <sup>3)</sup> lbs.	1450 RPM Input		1160 RPM Input		870 RPM Input	
Input HP	Output Torque in. lbs.		Motor Adapter	NEMA C-Frame Size <sup>4)</sup>	Input Shaft			Input HP	Output Torque in. lbs.	Input HP	Output Torque in. lbs.	Input HP	Output Torque in. lbs.
<b>40 RPM Output (Approximate) Continued</b>													
20.04	31,889	<b>C812_0460</b>	<b>MR250/210</b>	213/215/TC	<b>AW250/102</b>	45.538	5,733	16.61	31,889	13.28	31,889	9.96	31,889
20.04	31,889	<b>C812_0460</b>	<b>MR300/210</b>	213/215/TC	<b>AW300/110</b>	45.538	5,733	16.61	31,889	13.28	31,889	9.96	31,889
33.32	53,148	<b>C912_0460</b>	<b>MR300/250</b>	254/256TC	<b>AW300/110</b>	45.655	7,075	27.60	53,148	22.08	53,148	16.56	53,148
33.32	53,148	<b>C912_0460</b>	<b>MR350/320</b>	324/326TC	<b>AW350/202</b>	45.655	7,075	27.60	53,148	22.08	53,148	16.56	53,148
<b>35 RPM Output (Approximate)</b>													
0.30	531	<b>C002_0500</b>	<b>MR140/050</b>	56C	<b>AW140/010</b>	49.944	372	0.25	531	0.20	531	0.15	531
0.61	1,063	<b>C102_0500</b>	<b>MR140/050</b>	56C	<b>AW140/010</b>	49.944	528	0.50	1,063	0.40	1,063	0.30	1,063
1.03	1,772	<b>C202_0490</b>	<b>MR140/050</b>	56C	<b>AW140/010</b>	49.227	740	0.85	1,772	0.68	1,772	0.51	1,772
1.03	1,772	<b>C202_0490</b>	<b>MR160/050</b>	143/145TC	<b>AW160/012</b>	49.227	740	0.85	1,772	0.68	1,772	0.51	1,772
1.78	3,100	<b>C302_0500</b>	<b>MR160/050</b>	56C	<b>AW160/012</b>	49.745	1,104	1.48	3,100	1.18	3,100	0.89	3,100
1.78	3,100	<b>C302_0500</b>	<b>MR160/140</b>	143/145TC	<b>AW160/012</b>	49.745	1,104	1.48	3,100	1.18	3,100	0.89	3,100
2.78	4,872	<b>C402_0500</b>	<b>MR160/050</b>	56C	<b>AW160/012</b>	50.192	1,899	2.30	4,872	1.84	4,872	1.38	4,872
2.78	4,872	<b>C402_0500</b>	<b>MR160/140</b>	143/145TC	<b>AW160/012</b>	50.192	1,899	2.30	4,872	1.84	4,872	1.38	4,872
4.07	7,086	<b>C502_0500</b>	<b>MR160/050</b>	56C	<b>AW160/012</b>	49.821	2,326	3.37	7,086	2.70	7,086	2.02	7,086
4.07	7,086	<b>C502_0500</b>	<b>MR160/140</b>	143/145TC	<b>AW160/012</b>	49.821	2,326	3.37	7,086	2.70	7,086	2.02	7,086
4.07	7,086	<b>C502_0500</b>	<b>MR200/180</b>	182/184/TC	<b>AW200/014</b>	49.821	2,326	3.37	7,086	2.70	7,086	2.02	7,086
4.07	7,086	<b>C502_0500</b>	<b>MR250/180</b>	182/184/TC	<b>AW250/102</b>	49.821	2,326	3.37	7,086	2.70	7,086	2.02	7,086
7.57	12,844	<b>C613_0490</b>	<b>MR200/180</b>	182/184/TC	<b>AW200/014</b>	49.277	3,119	6.27	12,844	5.10	12,844	3.76	12,844
12.15	21,259	<b>C713_0510</b>	<b>MR250/180</b>	182/184/TC	<b>AW250/102</b>	50.845	4,322	10.07	21,259	8.05	21,259	6.04	21,259
17.52	29,662	<b>C813_0490</b>	<b>MR250/180</b>	182/184/TC	<b>AW250/102</b>	49.176	5,844	14.52	29,662	11.62	29,662	8.71	29,662
<b>30 RPM Output (Approximate) Continued Next Page</b>													
0.27	531	<b>C002_0560</b>	<b>MR140/050</b>	56C	<b>AW140/010</b>	55.972	382	0.23	531	0.18	531	0.14	531
0.54	1,063	<b>C102_0560</b>	<b>MR140/050</b>	56C	<b>AW140/010</b>	56.364	544	0.45	1,063	0.36	1,063	0.27	1,063
0.90	1,772	<b>C202_0560</b>	<b>MR140/050</b>	56C	<b>AW140/010</b>	56.424	766	0.74	1,772	0.60	1,772	0.45	1,772
0.90	1,772	<b>C202_0560</b>	<b>MR160/050</b>	56C	<b>AW160/012</b>	56.424	766	0.74	1,772	0.60	1,772	0.45	1,772
1.58	3,100	<b>C302_0560</b>	<b>MR160/050</b>	56C	<b>AW160/012</b>	56.136	1,138	1.31	3,100	1.05	3,100	0.79	3,100
1.58	3,100	<b>C302_0560</b>	<b>MR160/140</b>	143/145TC	<b>AW160/012</b>	56.136	1,138	1.31	3,100	1.05	3,100	0.79	3,100
2.49	4,872	<b>C402_0560</b>	<b>MR160/050</b>	56C	<b>AW160/012</b>	56.101	1,953	2.06	4,872	1.65	4,872	1.24	4,872
2.49	4,872	<b>C402_0560</b>	<b>MR160/140</b>	143/145TC	<b>AW160/012</b>	56.101	1,953	2.06	4,872	1.65	4,872	1.24	4,872
3.63	7,086	<b>C502_0560</b>	<b>MR160/050</b>	56C	<b>AW160/012</b>	55.833	2,393	3.01	7,086	2.41	7,086	1.81	7,086
3.63	7,086	<b>C502_0560</b>	<b>MR160/140</b>	143/145TC	<b>AW160/012</b>	55.833	2,393	3.01	7,086	2.41	7,086	1.81	7,086
3.63	7,086	<b>C502_0560</b>	<b>MR200/180</b>	182/184/TC	<b>AW200/014</b>	55.833	2,393	3.01	7,086	2.41	7,086	1.81	7,086
3.63	7,086	<b>C502_0560</b>	<b>MR250/180</b>	182/184/TC	<b>AW250/102</b>	55.833	2,393	3.01	7,086	2.41	7,086	1.81	7,086
5.98	11,515	<b>C612_0550</b>	<b>MR200/180</b>	182/184/TC	<b>AW200/014</b>	55.111	3,207	4.95	11,515	3.96	11,515	2.97	11,515
5.98	11,515	<b>C612_0550</b>	<b>MR250/210</b>	213/215/TC	<b>AW250/102</b>	55.111	3,207	4.95	11,515	3.96	11,515	2.97	11,515
8.92	17,716	<b>C712_0570</b>	<b>MR200/180</b>	182/184/TC	<b>AW200/014</b>	56.818	4,443	7.39	17,716	5.91	17,716	4.44	17,716
8.92	17,716	<b>C712_0570</b>	<b>MR250/180</b>	182/184/TC	<b>AW250/102</b>	56.818	4,443	7.39	17,716	5.91	17,716	4.44	17,716
8.92	17,716	<b>C712_0570</b>	<b>MR300/280</b>	284/286TC	<b>AW300/110</b>	56.818	4,443	7.39	17,716	5.91	17,716	4.44	17,716

\* For thermal HP capacity, see rating below.

Base Module	C0	C1	C2	C3	C4	C5	C6	C7	C8	C9
Thermal Capacity	2.95	5.36	7.38	12.34	14.75	20.12	29.50	40.23	53.64	67.05

NEMA Frame Size  
TEFC 1750 RPM

C-Frame	Motor HP
56C	1/3 - 1/2
143/145TC	1, 1 1/2, 2
182/184TC	3, 5
213/215TC	7 1/2, 10
254/256TC	15, 20
284/286TC	25, 30
324/326TC	40, 50
364/365TC	60, 75

### Housing Styles

N – Foot Mounted    F – Round Flange    Q – Square Flange    G – Tapped Holes

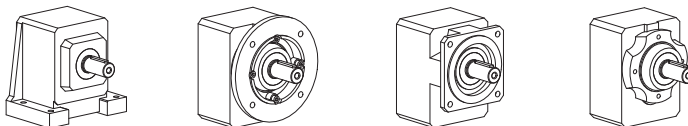

Housing Style Q is available on special order.



# "C" Series – Concentric Helical MGS Reducer – Selection Data



- NOTE:** 1) Complete Base Module Part Number by adding Housing Style. Example: C302N0560.  
 2) Select Input Option and add to completed Part Number. See example below.  
 3) Overhung Load is measured at the center of the shaft extension. Hollow output units are not intended to support overhung loads. If a load rating is required, use 50% of the published overhung load.  
 4) Other frame sizes may also be available. See dimension pages.

1750 RPM Input		Base Module <sup>1)</sup>	Input Options <sup>2)</sup>			Exact Ratio	Overhung Load Output Shaft <sup>3)</sup> lbs.	1450 RPM Input		1160 RPM Input		870 RPM Input	
Input HP	Output Torque in. lbs.		Motor Adapter	NEMA C-Frame Size <sup>4)</sup>	Input Shaft			Input HP	Output Torque in. lbs.	Input HP	Output Torque in. lbs.	Input HP	Output Torque in. lbs.
<b>30 RPM Output (Approximate) Continued</b>													
<b>25 RPM</b>				<b>21 RPM</b>				<b>15 RPM</b>					
16.85	31,889	C812_0540	MR250/180	182/184/TC	AW250/102	54.154	5,987	13.96	31,889	11.17	31,889	8.38	31,889
16.85	31,889	C812_0540	MR300/180	182/184/TC	AW300/110	54.154	5,987	13.96	31,889	11.17	31,889	8.38	31,889
27.24	53,148	C912_0560	MR300/210	213/215/TC	AW300/110	55.833	7,441	22.57	53,148	18.06	53,148	13.54	53,148
<b>28 RPM Output (Approximate)</b>													
<b>23 RPM</b>				<b>19 RPM</b>				<b>14 ORPM</b>					
0.24	531	C002_0620	MR140/050	56C	AW140/010	62.350	393	0.20	531	0.16	531	0.12	531
0.48	1,054	C102_0620	MR140/050	56C	AW140/010	62.431	558	0.40	1,054	0.32	1,054	0.24	1,054
0.77	1,658	C202_0610	MR140/050	56C	AW140/010	61.354	782	0.64	1,658	0.51	1,658	0.38	1,658
1.35	2,932	C302_0620	MR160/050	56C	AW160/012	61.920	1,166	1.12	2,932	0.90	2,932	0.67	2,932
1.35	2,932	C302_0620	MR160/140	143/145TC	AW160/012	61.920	1,166	1.12	2,932	0.90	2,932	0.67	2,932
2.03	4,440	C402_0630	MR160/050	56C	AW160/012	62.515	2,007	1.68	4,440	1.35	4,440	1.01	4,440
2.03	4,440	C402_0630	MR160/140	143/145TC	AW160/012	62.515	2,007	1.68	4,440	1.35	4,440	1.01	4,440
2.90	6,325	C502_0620	MR160/050	56C	AW160/012	62.431	2,461	2.40	6,325	1.92	6,325	1.44	6,325
2.90	6,325	C502_0620	MR160/140	143/145TC	AW160/012	62.431	2,461	2.40	6,325	1.92	6,325	1.44	6,325
5.88	12,844	C613_0630	MR200/180	182/184/TC	AW200/014	63.462	3,322	4.87	12,844	3.90	12,844	2.92	12,844
9.57	21,259	C713_0650	MR250/180	182/184/TC	AW250/102	64.547	4,587	7.93	21,259	6.34	21,259	4.76	21,259
15.48	35,139	C813_0660	MR250/180	182/184/TC	AW250/102	65.963	6,290	13.58	37,204	10.86	37,204	8.15	37,204
<b>25 RPM Output (Approximate)</b>													
<b>20 RPM</b>				<b>18 RPM</b>				<b>13 ORPM</b>					
0.22	531	C002_0700	MR140/050	56C	AW140/010	69.875	404	0.18	531	0.14	531	0.11	531
0.43	1,063	C102_0700	MR140/050	56C	AW140/010	70.455	575	0.36	1,063	0.29	1,063	0.21	1,063
0.72	1,772	C202_0700	MR140/050	56C	AW140/010	70.324	810	0.60	1,772	0.48	1,772	0.36	1,772
1.27	3,100	C302_0700	MR160/050	56C	AW160/012	69.875	1,202	1.05	3,100	0.84	3,100	0.63	3,100
1.27	3,100	C302_0700	MR160/140	143/145TC	AW160/012	69.875	1,202	1.05	3,100	0.84	3,100	0.63	3,100
2.00	4,872	C402_0700	MR160/050	56C	AW160/012	69.875	2,063	1.65	4,872	1.32	4,872	0.99	4,872
2.00	4,872	C402_0700	MR160/140	143/145TC	AW160/012	69.875	2,063	1.65	4,872	1.32	4,872	0.99	4,872
2.90	7,086	C502_0700	MR160/050	56C	AW160/012	69.965	2,532	2.40	7,086	1.92	7,086	1.44	7,086
2.90	7,086	C502_0700	MR160/140	143/145TC	AW160/012	69.965	2,532	2.40	7,086	1.92	7,086	1.44	7,086
4.78	11,515	C612_0690	MR200/180	182/184/TC	AW200/014	68.889	3,391	3.96	11,515	3.17	11,515	2.38	11,515
4.78	11,515	C612_0690	MR250/210	213/215/TC	AW250/102	68.889	3,391	3.96	11,515	3.17	11,515	2.38	11,515
7.29	17,716	C712_0700	MR200/180	182/184/TC	AW200/014	69.545	4,674	6.04	17,716	4.83	17,716	3.62	17,716
7.29	17,716	C712_0700	MR250/180	182/184/TC	AW250/102	69.545	4,674	6.04	17,716	4.83	17,716	3.62	17,716
13.25	31,889	C812_0690	MR250/180	182/184/TC	AW250/102	68.889	6,358	10.98	31,889	8.78	31,889	6.59	31,889
13.25	31,889	C812_0690	MR300/210	213/215/TC	AW300/110	68.889	6,358	10.98	31,889	8.78	31,889	6.59	31,889
21.74	53,148	C912_0700	MR300/280	284/286TC	AW300/110	69.965	7,872	18.01	53,148	14.41	53,148	10.81	53,148

### Part No. Explanation

C 3 0 2 N 0620 AW 140 /012

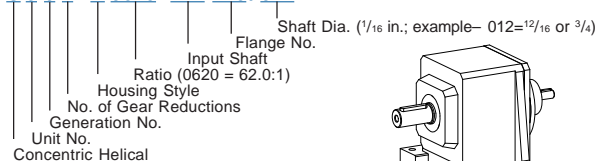

C 3 0 2 N 0620 MR 160 /140

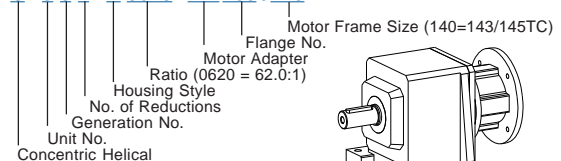

**Mounting position must be specified when ordering.**



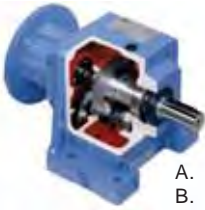

# "C" Series – Concentric Helical MGS Reducer – Selection Data



## Selection Procedure:

- Under the Input RPM heading, find **Approximate Output RPM** nearest the requirement.
- In the **Input HP** column locate the rating that is greater than or equal to the required HP.  
(If selection is based on Torque instead of HP, find an **Output Torque** that is equal to or greater than required.)
- When HP or Torque rating is located, read across that row to select the **Base Module**, **Input Option** and **Overhung Loads**.
- If exact **Output RPM** is required, divide the **Input RPM** by the **Exact Ratio**.

1750 RPM Input		Base Module <sup>1)</sup>	Input Options <sup>2)</sup>			Exact Ratio	Overhung Load Output Shaft <sup>3)</sup> lbs.	1450 RPM Input		1160 RPM Input		870 RPM Input	
Input HP	Output Torque in. lbs.		Motor Adapter	NEMA C-Frame Size <sup>4)</sup>	Input Shaft			Input HP	Output Torque in. lbs.	Input HP	Output Torque in. lbs.	Input HP	Output Torque in. lbs.
<b>20 RPM Output (Approximate)</b>													
0.38	1,063	<b>C103_0820</b>	<b>MR140/050</b>	56C	<b>AW140/010</b>	81.638	597	0.31	1,063	0.25	1,063	0.19	1,063
0.64	1,772	<b>C203_0810</b>	<b>MR140/050</b>	56C	<b>AW140/010</b>	80.618	838	0.53	1,772	0.42	1,772	0.32	1,772
0.65	1,772	<b>C203_0800</b>	<b>MR160/050</b>	56C	<b>AW160/012</b>	79.589	835	0.54	1,772	0.43	1,772	0.32	1,772
1.07	3,003	<b>C303_0810</b>	<b>MR140/050</b>	56C	<b>AW140/010</b>	81.467	1,249	0.89	3,003	0.71	3,003	0.53	3,003
1.12	3,100	<b>C303_0800</b>	<b>MR160/050</b>	56C	<b>AW160/012</b>	80.427	1,245	0.93	3,100	0.74	3,100	0.56	3,100
1.12	3,100	<b>C303_0800</b>	<b>MR160/140</b>	143/145TC	<b>AW160/012</b>	80.427	1,245	0.93	3,100	0.74	3,100	0.56	3,100
1.75	4,872	<b>C403_0810</b>	<b>MR160/050</b>	56C	<b>AW160/012</b>	80.810	2,140	1.45	4,872	1.16	4,872	0.87	4,872
1.75	4,872	<b>C403_0810</b>	<b>MR160/140</b>	143/145TC	<b>AW160/012</b>	80.810	2,140	1.45	4,872	1.16	4,872	0.87	4,872
2.55	7,086	<b>C503_0810</b>	<b>MR160/050</b>	56C	<b>AW160/012</b>	80.596	2,623	2.12	7,086	1.69	7,086	1.27	7,086
2.55	7,086	<b>C503_0810</b>	<b>MR160/140</b>	143/145TC	<b>AW160/012</b>	80.596	2,623	2.12	7,086	1.69	7,086	1.27	7,086
2.97	7,745	<b>C613_0760</b>	<b>MR160/050</b>	56C	<b>AW160/012</b>	75.814	3,473	2.46	7,745	1.97	7,745	1.48	7,745
2.97	7,745	<b>C613_0760</b>	<b>MR160/140</b>	143/145TC	<b>AW160/012</b>	75.814	3,473	2.46	7,745	1.97	7,745	1.48	7,745
4.86	12,844	<b>C613_0770</b>	<b>MR200/180</b>	182/184/TC	<b>AW200/014</b>	76.795	3,484	4.03	12,844	3.22	12,844	2.42	12,844
6.82	19,007	<b>C713_0810</b>	<b>MR200/180</b>	182/184/TC	<b>AW200/014</b>	80.965	4,855	6.02	20,237	5.06	21,259	3.79	21,259
7.75	21,259	<b>C713_0800</b>	<b>MR250/180</b>	182/184/TC	<b>AW250/102</b>	79.734	4,836	6.42	21,259	5.13	21,259	3.85	21,259
7.97	21,754	<b>C813_0790</b>	<b>MR200/180</b>	182/184/TC	<b>AW200/014</b>	79.339	6,587	6.60	21,754	5.28	21,754	3.96	21,754
13.70	36,844	<b>C813_0780</b>	<b>MR250/210</b>	213/215/TC	<b>AW250/102</b>	78.133	6,562	11.46	37,204	9.17	37,204	6.88	37,204
15.60	41,738	<b>C913_0780</b>	<b>MR250/210</b>	213/215/TC	<b>AW250/102</b>	77.728	8,082	13.76	44,438	11.02	44,495	8.27	44,495

<b>19 RPM Output (Approximate)</b>													
0.34	1,063	<b>C103_0920</b>	<b>MR140/050</b>	56C	<b>AW140/010</b>	92.131	608	0.28	1,063	0.22	1,063	0.17	1,063
0.56	1,772	<b>C203_0920</b>	<b>MR140/050</b>	56C	<b>AW140/010</b>	92.404	855	0.46	1,772	0.37	1,772	0.28	1,772
0.56	1,772	<b>C203_0910</b>	<b>MR160/050</b>	56C	<b>AW160/012</b>	91.225	855	0.47	1,772	0.37	1,772	0.28	1,772
0.98	3,100	<b>C303_0920</b>	<b>MR140/050</b>	56C	<b>AW140/010</b>	91.933	1,271	0.81	3,100	0.65	3,100	0.49	3,100
0.99	3,100	<b>C303_0910</b>	<b>MR160/050</b>	56C	<b>AW160/012</b>	90.759	1,271	0.82	3,100	0.66	3,100	0.49	3,100
1.57	4,872	<b>C403_0900</b>	<b>MR160/050</b>	56C	<b>AW160/012</b>	90.323	2,183	1.30	4,872	1.04	4,872	0.78	4,872
1.57	4,872	<b>C403_0900</b>	<b>MR160/140</b>	143/145TC	<b>AW160/012</b>	90.323	2,183	1.30	4,872	1.04	4,872	0.78	4,872
2.28	7,086	<b>C503_0900</b>	<b>MR160/050</b>	56C	<b>AW160/012</b>	90.323	2,678	1.89	7,086	1.51	7,086	1.13	7,086
2.28	7,086	<b>C503_0900</b>	<b>MR160/140</b>	143/145TC	<b>AW160/012</b>	90.323	2,678	1.89	7,086	1.51	7,086	1.13	7,086
3.08	9,299	<b>C613_0880</b>	<b>MR160/050</b>	56C	<b>AW160/012</b>	87.644	3,600	2.55	9,299	2.04	9,299	1.53	9,299
3.08	9,299	<b>C613_0880</b>	<b>MR160/140</b>	143/145TC	<b>AW160/012</b>	87.644	3,600	2.55	9,299	2.04	9,299	1.53	9,299
3.77	11,515	<b>C613_0890</b>	<b>MR200/180</b>	182/184/TC	<b>AW200/014</b>	88.778	3,600	3.12	11,515	2.50	11,515	1.87	11,515
5.76	17,716	<b>C713_0890</b>	<b>MR250/180</b>	182/184/TC	<b>AW250/102</b>	89.416	4,950	4.77	17,716	3.82	17,716	2.86	17,716
7.97	24,905	<b>C813_0910</b>	<b>MR200/180</b>	182/184/TC	<b>AW200/014</b>	90.821	6,750	6.60	24,905	5.28	24,905	3.96	24,905
10.36	31,889	<b>C813_0890</b>	<b>MR250/210</b>	213/215/TC	<b>AW250/102</b>	89.441	6,750	8.58	31,889	6.87	31,889	5.15	31,889
17.12	53,148	<b>C913_0900</b>	<b>MR250/180</b>	182/184/TC	<b>AW250/102</b>	90.219	8,325	14.18	53,148	11.35	53,148	8.51	53,148

\* For thermal HP capacity, see rating below.

Base Module	C0	C1	C2	C3	C4	C5	C6	C7	C8	C9
Thermal Capacity	2.95	5.36	7.38	12.34	14.75	20.12	29.50	40.23	53.64	67.05

NEMA Frame Size  
TEFC 1750 RPM

C-Frame	Motor HP
56C	1/3 - 1 1/2
143/145TC	1, 1 1/2, 2
182/184TC	3, 5
213/215TC	7 1/2, 10
254/256TC	15, 20
284/286TC	25, 30
324/326TC	40, 50
364/365TC	60, 75

## Housing Styles

N – Foot Mounted    F – Round Flange    Q – Square Flange    G – Tapped Holes

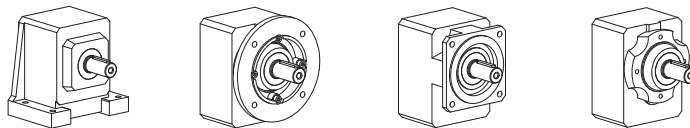

Housing Style Q is available on special order.





# "C" Series – Concentric Helical MGS Reducer – Selection Data



- NOTE:** 1) Complete Base Module Part Number by adding Housing Style. Example: C302N0560.  
 2) Select Input Option and add to completed Part Number. See example below.  
 3) Overhung Load is measured at the center of the shaft extension. Hollow output units are not intended to support overhung loads. If a load rating is required, use 50% of the published overhung load.  
 4) Other frame sizes may also be available. See dimension pages.

1750 RPM Input		Base Module <sup>1)</sup>	Input Options <sup>2)</sup>			Exact Ratio	Overhung Load Output Shaft <sup>3)</sup> lbs.	1450 RPM Input		1160 RPM Input		870 RPM Input	
Input HP	Output Torque in. lbs.		Motor Adapter	NEMA C-Frame Size <sup>4)</sup>	Input Shaft			Input HP	Output Torque in. lbs.	Input HP	Output Torque in. lbs.	Input HP	Output Torque in. lbs.
<b>18 RPM Output (Approximate)</b>													
3.82	12,844	C613_0980	MR200/180	182/184/TC	AW200/014	97.634	3,600	3.17	12,844	2.53	12,844	1.90	12,844
5.95	20,308	C713_0990	MR200/180	182/184/TC	AW200/014	99.141	4,950	5.16	21,259	4.13	21,259	3.10	21,259
6.33	21,259	C713_0980	MR250/210	213/215/TC	AW250/102	97.634	4,950	5.24	21,259	4.19	21,259	3.15	21,259
10.75	37,204	C813_1010	MR250/180	182/184/TC	AW250/102	100.511	6,750	8.91	37,204	7.13	37,204	5.35	37,204
<b>16 RPM Output (Approximate)</b>													
0.28	1,063	C103_1110	MR140/050	56C	AW140/010	111.091	608	0.23	1,063	0.18	1,063	0.14	1,063
0.47	1,772	C203_1110	MR140/050	56C	AW140/010	110.619	855	0.39	1,772	0.31	1,772	0.23	1,772
0.47	1,772	C203_1090	MR160/050	56C	AW160/012	109.206	855	0.39	1,772	0.31	1,772	0.23	1,772
0.82	3,100	C303_1100	MR140/050	56C	AW140/010	109.612	1,271	0.68	3,100	0.54	3,100	0.41	3,100
0.83	3,100	C303_1080	MR160/050	56C	AW160/012	108.213	1,271	0.69	3,100	0.55	3,100	0.41	3,100
1.31	4,872	C403_1080	MR160/050	56C	AW160/012	107.714	2,183	1.09	4,872	0.87	4,872	0.65	4,872
1.31	4,872	C403_1080	MR160/140	143/145TC	AW160/012	107.714	2,183	1.09	4,872	0.87	4,872	0.65	4,872
1.90	7,086	C503_1090	MR160/050	56TC	AW160/012	108.649	2,678	1.57	7,086	1.26	7,086	0.94	7,086
1.90	7,086	C503_1090	MR160/140	143/145TC	AW160/012	108.649	2,678	1.57	7,086	1.26	7,086	0.94	7,086
2.97	10,835	C613_1060	MR160/050	56C	AW160/012	106.057	3,600	2.46	10,835	1.97	10,835	1.48	10,835
2.97	10,835	C613_1060	MR160/140	143/145TC	AW160/012	106.057	3,600	2.46	10,835	1.97	10,835	1.48	10,835
3.11	11,515	C613_1070	MR200/180	182/184/TC	AW200/014	107.429	3,600	2.58	11,515	2.06	11,515	1.55	11,515
4.66	17,716	C713_1100	MR250/180	182/184/TC	AW250/102	110.455	4,950	3.86	17,716	3.09	17,716	2.32	17,716
7.97	29,498	C813_1080	MR200/180	182/184/TC	AW200/014	107.578	6,750	6.60	29,498	5.28	29,498	3.96	29,498
8.75	31,889	C813_1060	MR250/180	182/184/TC	AW250/102	105.943	6,750	7.25	31,889	5.80	31,889	4.35	31,889
13.98	53,148	C913_1100	MR250/180	182/184/TC	AW250/102	110.434	8,325	11.59	53,148	9.27	53,148	6.95	53,148
<b>14 RPM Output (Approximate)</b>													
4.67	21,259	C713_1320	MR200/180	182/184/TC	AW200/014	132.371	4,950	3.87	21,259	3.09	21,259	2.32	21,259
4.74	21,259	C713_1300	MR250/180	182/184/TC	AW250/102	130.359	4,950	3.93	21,259	3.14	21,259	2.36	21,259
8.34	37,204	C813_1300	MR250/180	182/184/TC	AW250/102	129.541	6,750	6.91	37,204	5.53	37,204	4.15	37,204
<b>13 RPM Output (Approximate) Continued Next Page</b>													
<b>10 RPM</b>													
0.22	1,063	C103_1370	MR140/050	56C	AW140/010	137.338	608	0.19	1,063	0.15	1,063	0.11	1,063
0.37	1,772	C203_1380	MR140/050	56C	AW140/010	137.786	855	0.31	1,772	0.25	1,772	0.19	1,772
0.38	1,772	C203_1360	MR160/050	56C	AW160/012	136.027	855	0.31	1,772	0.25	1,772	0.19	1,772
0.66	3,100	C303_1370	MR140/050	56C	AW140/010	137.192	1,271	0.54	3,100	0.44	3,100	0.33	3,100
0.67	3,100	C303_1350	MR160/050	56C	AW160/012	135.441	1,271	0.55	3,100	0.44	3,100	0.33	3,100
1.05	4,872	C403_1350	MR160/050	56C	AW160/012	134.643	2,183	0.87	4,872	0.70	4,872	0.52	4,872
1.05	4,872	C403_1350	MR160/140	143/145TC	AW160/012	134.643	2,183	0.87	4,872	0.70	4,872	0.52	4,872
1.52	7,086	C503_1350	MR160/050	56C	AW160/012	135.333	2,678	1.26	7,086	1.01	7,086	0.76	7,086
1.52	7,086	C503_1350	MR160/140	143/145TC	AW160/012	135.333	2,678	1.26	7,086	1.01	7,086	0.76	7,086
2.48	11,515	C613_1350	MR160/050	56C	AW160/012	134.838	3,600	2.06	11,515	1.64	11,515	1.23	11,515
2.48	11,515	C613_1350	MR160/140	143/145TC	AW160/012	134.838	3,600	2.06	11,515	1.64	11,515	1.23	11,515
3.75	17,716	C713_1370	MR200/180	182/184/TC	AW200/014	137.338	4,950	3.11	17,716	2.48	17,716	1.86	17,716

### Part No. Explanation

**C 3 0 2 N 0620 AW 140 / 012**

Unit No.  
Concentric Helical

Generation No.  
No. of Gear Reductions

Housing Style  
Ratio (0620 = 62.0:1)

Input Shaft  
Flange No.

Shaft Dia. (1/16 in.; example- 012=1 1/16 or 3/4)

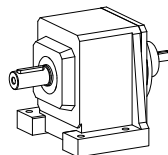

**C 3 0 2 N 0620 MR 160 / 140**

Unit No.  
Concentric Helical

Generation No.  
No. of Reductions

Housing Style  
Ratio (0620 = 62.0:1)

Motor Adapter  
Flange No.

Motor Frame Size (140=143/145TC)

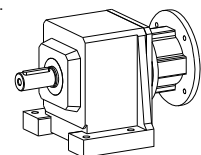

**Mounting position must be specified when ordering.**

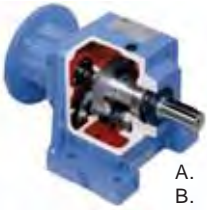

# "C" Series – Concentric Helical MGS Reducer – Selection Data



### Selection Procedure:

- Under the Input RPM heading, find **Approximate Output RPM** nearest the requirement.
- In the **Input HP** column locate the rating that is greater than or equal to the required HP.  
(If selection is based on Torque instead of HP, find an **Output Torque** that is equal to or greater than required.)
- When HP or Torque rating is located, read across that row to select the **Base Module**, **Input Option** and **Overhung Loads**.
- If exact **Output RPM** is required, divide the **Input RPM** by the **Exact Ratio**.

1750 RPM Input		Base Module <sup>1)</sup>	Input Options <sup>2)</sup>			Exact Ratio	Overhung Load Output Shaft <sup>3)</sup> lbs.	1450 RPM Input		1160 RPM Input		870 RPM Input	
Input HP	Output Torque in. lbs.		Motor Adapter	NEMA C-Frame Size <sup>4)</sup>	Input Shaft			Input HP	Output Torque in. lbs.	Input HP	Output Torque in. lbs.	Input HP	Output Torque in. lbs.
<b>13 RPM Output (Approximate) Continued</b>													
3.81	17,716	<b>C713_1350</b>	<b>MR250/180</b>	182/184/TC	<b>AW250/102</b>	135.250	4,950	3.15	17,716	2.52	17,716	1.89	17,716
6.70	31,889	<b>C813_1380</b>	<b>MR200/180</b>	182/184/TC	<b>AW200/014</b>	138.389	6,750	5.55	31,889	4.44	31,889	3.33	31,889
6.80	31,889	<b>C813_1360</b>	<b>MR250/180</b>	182/184/TC	<b>AW250/102</b>	136.286	6,750	5.63	31,889	4.51	31,889	3.38	31,889
11.12	53,148	<b>C913_1390</b>	<b>MR250/180</b>	182/184/TC	<b>AW250/102</b>	138.876	8,325	9.21	53,148	7.37	53,148	5.53	53,148
<b>10 RPM Output (Approximate)</b>													
1.91	11,515	<b>C613_1750</b>	<b>MR160/050</b>	56C	<b>AW160/012</b>	175.289	3,600	1.58	11,515	1.27	11,515	0.95	11,515
1.91	11,515	<b>C613_1750</b>	<b>MR160/140</b>	143/145TC	<b>AW160/012</b>	175.289	3,600	1.58	11,515	1.27	11,515	0.95	11,515
5.19	31,889	<b>C813_1780</b>	<b>MR200/180</b>	182/184/TC	<b>AW200/014</b>	178.359	6,750	4.30	31,889	3.44	31,889	2.58	31,889
5.27	31,889	<b>C813_1760</b>	<b>MR250/180</b>	182/184/TC	<b>AW250/102</b>	175.648	6,750	4.37	31,889	3.50	31,889	2.62	31,889
8.77	53,148	<b>C913_1760</b>	<b>MR250/210</b>	213/215/TC	<b>AW250/102</b>	176.097	8,325	7.27	53,148	5.81	53,148	4.36	53,148
<b>9.5 RPM Output (Approximate)</b>													
0.17	1,063	<b>C103_1840</b>	<b>MR140/050</b>	56C	<b>AW140/010</b>	183.727	608	0.14	1,063	0.11	1,063	0.08	1,063
0.28	1,772	<b>C203_1830</b>	<b>MR140/050</b>	56C	<b>AW140/010</b>	183.387	855	0.23	1,772	0.19	1,772	0.14	1,772
0.28	1,772	<b>C203_1810</b>	<b>MR160/050</b>	56C	<b>AW160/012</b>	181.046	855	0.24	1,772	0.19	1,772	0.14	1,772
0.49	3,100	<b>C303_1830</b>	<b>MR140/050</b>	56C	<b>AW140/010</b>	182.778	1,271	0.41	3,100	0.33	3,100	0.25	3,100
0.50	3,100	<b>C303_1800</b>	<b>MR160/050</b>	56C	<b>AW160/012</b>	180.444	1,271	0.41	3,100	0.33	3,100	0.25	3,100
0.78	4,872	<b>C403_1800</b>	<b>MR160/050</b>	56C	<b>AW160/012</b>	180.444	2,183	0.65	4,872	0.52	4,872	0.39	4,872
1.14	7,086	<b>C503_1810</b>	<b>MR160/050</b>	56C	<b>AW160/012</b>	180.646	2,678	0.94	7,086	0.76	7,086	0.57	7,086
1.14	7,086	<b>C503_1810</b>	<b>MR160/140</b>	143/145TC	<b>AW160/012</b>	180.646	2,678	0.94	7,086	0.76	7,086	0.57	7,086
2.81	17,716	<b>C713_1830</b>	<b>MR160/050</b>	56C	<b>AW160/012</b>	183.371	4,950	2.33	17,716	1.86	17,716	1.40	17,716
2.81	17,716	<b>C713_1830</b>	<b>MR160/140</b>	143/145TC	<b>AW160/012</b>	183.371	4,950	2.33	17,716	1.86	17,716	1.40	17,716
<b>8 RPM Output (Approximate)</b>													
0.14	1,063	<b>C103_2210</b>	<b>MR140/050</b>	56C	<b>AW140/010</b>	220.758	608	0.12	1,063	0.09	1,063	0.07	1,063
0.23	1,772	<b>C203_2210</b>	<b>MR140/050</b>	56C	<b>AW140/010</b>	220.995	855	0.19	1,772	0.15	1,772	0.12	1,772
0.41	3,100	<b>C303_2200</b>	<b>MR140/050</b>	56C	<b>AW140/010</b>	219.867	1,271	0.34	3,100	0.27	3,100	0.20	3,100
0.41	3,100	<b>C303_2170</b>	<b>MR160/050</b>	56C	<b>AW160/012</b>	217.061	1,271	0.34	3,100	0.28	3,100	0.21	3,100
0.65	4,872	<b>C403_2170</b>	<b>MR160/050</b>	56C	<b>AW160/012</b>	216.925	2,183	0.54	4,872	0.43	4,872	0.32	4,872
0.95	7,086	<b>C503_2160</b>	<b>MR160/050</b>	56C	<b>AW160/012</b>	215.889	2,678	0.79	7,086	0.63	7,086	0.47	7,086
1.57	11,515	<b>C613_2130</b>	<b>MR160/050</b>	56C	<b>AW160/012</b>	213.096	3,600	1.30	11,515	1.04	11,515	0.78	11,515
1.57	11,515	<b>C613_2130</b>	<b>MR160/140</b>	143/145TC	<b>AW160/012</b>	213.096	3,600	1.30	11,515	1.04	11,515	0.78	11,515
4.37	31,889	<b>C813_2120</b>	<b>MR200/180</b>	182/184/TC	<b>AW200/014</b>	212.103	6,750	3.62	31,889	2.90	31,889	2.17	31,889
4.44	31,889	<b>C813_2090</b>	<b>MR250/180</b>	182/184/TC	<b>AW250/102</b>	208.879	6,750	3.68	31,889	2.94	31,889	2.21	31,889
7.17	53,148	<b>C913_2150</b>	<b>MR250/180</b>	182/184/TC	<b>AW250/102</b>	215.357	8,325	5.94	53,148	4.75	53,148	3.56	53,148

\* For thermal HP capacity, see rating below.

Base Module	C0	C1	C2	C3	C4	C5	C6	C7	C8	C9
Thermal Capacity	2.95	5.36	7.38	12.34	14.75	20.12	29.50	40.23	53.64	67.05

### NEMA Frame Size TEFC 1750 RPM

C-Frame	Motor HP
56C	1/3 - 1 1/2
143/145TC	1, 1 1/2, 2
182/184TC	3, 5
213/215TC	7 1/2, 10
254/256TC	15, 20
284/286TC	25, 30
324/326TC	40, 50
364/365TC	60, 75

### Housing Styles

**N** – Foot Mounted    **F** – Round Flange    **Q** – Square Flange    **G** – Tapped Holes

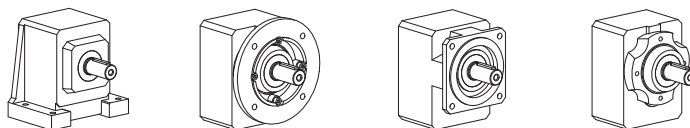

Housing Style Q is available on special order.



# "C" Series – Concentric Helical MGS Reducer – Selection Data



- NOTE:** 1) Complete Base Module Part Number by adding Housing Style. Example: C302N0560.  
 2) Select Input Option and add to completed Part Number. See example below.  
 3) Overhung Load is measured at the center of the shaft extension. Hollow output units are not intended to support overhung loads. If a load rating is required, use 50% of the published overhung load.  
 4) Other frame sizes may also be available. See dimension pages.

1750 RPM Input		Base Module <sup>1)</sup>	Input Options <sup>2)</sup>			Exact Ratio	Overhung Load Output Shaft <sup>3)</sup> lbs.	1450 RPM Input		1160 RPM Input		870 RPM Input	
Input HP	Output Torque in. lbs.		Motor Adapter	NEMA C-Frame Size <sup>4)</sup>	Input Shaft			Input HP	Output Torque in. lbs.	Input HP	Output Torque in. lbs.	Input HP	Output Torque in. lbs.
<b>6.5 RPM Output (Approximate)</b>													
								<b>5 RPM</b>		<b>4 RPM</b>		<b>3 RPM</b>	
0.11	1,063	<b>C103_2760</b>	<b>MR140/050</b>	56C	<b>AW140/010</b>	275.947	608	0.09	1,063	0.07	1,063	0.06	1,063
0.19	1,772	<b>C203_2750</b>	<b>MR140/050</b>	56C	<b>AW140/010</b>	275.436	855	0.15	1,772	0.12	1,772	0.09	1,772
0.33	3,100	<b>C303_2740</b>	<b>MR140/050</b>	56C	<b>AW140/010</b>	273.677	1,271	0.27	3,100	0.22	3,100	0.16	3,100
0.52	4,872	<b>C403_2700</b>	<b>MR160/050</b>	56C	<b>AW160/012</b>	270.183	2,183	0.43	4,872	0.35	4,872	0.26	4,872
0.76	7,086	<b>C503_2710</b>	<b>MR160/050</b>	56C	<b>AW160/012</b>	270.532	2,678	0.63	7,086	0.50	7,086	0.38	7,086
1.26	11,515	<b>C613_2660</b>	<b>MR160/050</b>	56C	<b>AW160/012</b>	266.370	3,600	1.04	11,515	0.83	11,515	0.62	11,515
1.26	11,515	<b>C613_2660</b>	<b>MR160/140</b>	143/145TC	<b>AW160/012</b>	266.370	3,600	1.04	11,515	0.83	11,515	0.62	11,515
3.43	31,889	<b>C813_2700</b>	<b>MR200/180</b>	182/184/TC	<b>AW200/014</b>	269.815	6,750	2.85	31,889	2.28	31,889	1.71	31,889
3.49	31,889	<b>C813_2660</b>	<b>MR250/180</b>	182/184/TC	<b>AW250/102</b>	265.714	6,750	2.89	31,889	2.31	31,889	1.73	31,889

**NOTE: For slower speeds than those listed above, units can be combined. Contact STOBER Drives Inc.**

### Part No. Explanation

**C 3 0 2 N 0620 AW 140 /012**

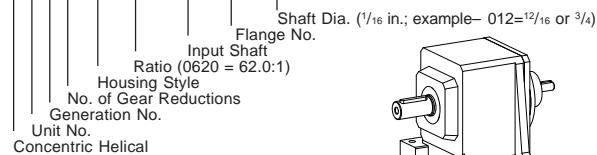

**C 3 0 2 N 0620 MR 160 /140**

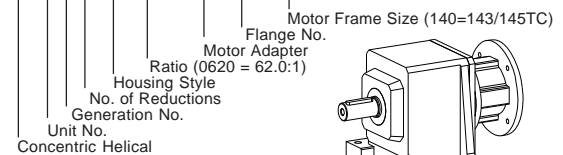

**Mounting position must be specified when ordering.**

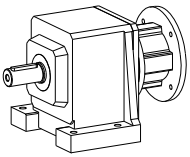

# "C" Series – MGS Reducer Foot Mount – "N" Housing Dimensional Data

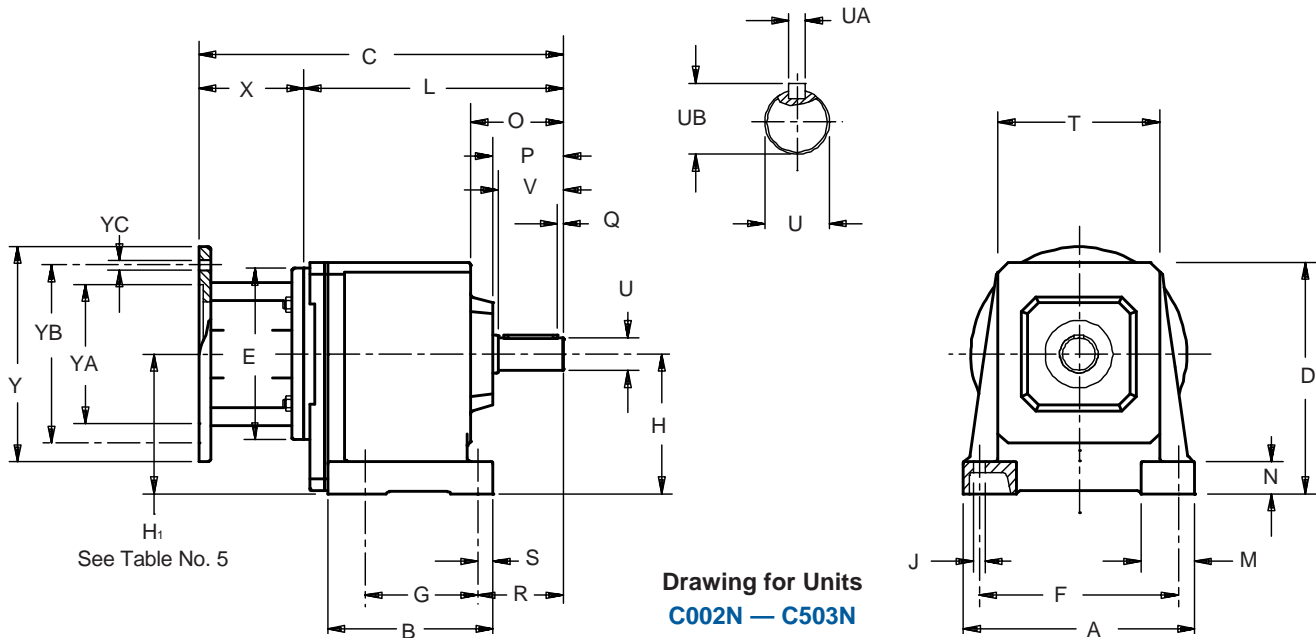

**Table No. 1 "C" Series – Foot Mounting Unit Dimensions (Inches) – "N" Housing Style**

Base Module	A	B	D	F	G	H	J	M	N	O	P	Q	R	S	T	V	Z <sub>1</sub>
<b>C002</b>	5.20	3.74	5.67	4.33	2.44	3.23	.28	1.38	.79	2.24	1.73	.16	2.17	.43	3.62	1.57	—
<b>C102/C103</b>	6.93	4.65	6.97	5.91	2.76	4.02	.35	1.65	.98	2.72	2.13	.16	2.64	.51	4.88	1.97	—
<b>C202/C203</b>	7.87	5.31	7.68	6.69	3.35	4.53	.43	1.97	1.18	3.39	2.56	.16	3.11	.55	5.43	2.36	—
<b>C302/C303</b>	8.46	6.06	8.46	7.28	4.13	5.12 <sup>1)</sup>	.43	1.97	1.18	3.35	2.56	.16	3.11	.55	5.91	2.36	—
<b>C402/C403</b>	10.04	7.09	9.65	8.66	4.33	5.71	.55	2.36	1.38	4.17	3.39	.16	4.13	.75	6.89	3.15	—
<b>C502/C503</b>	11.42	7.76	11.42	9.65	5.12	6.69	.71	2.76	1.57	4.21	3.39	.16	4.25	.87	7.56	3.15	—
<b>C612/C613</b>	11.81	10.43	12.40	9.65	8.46	7.87 <sup>1)</sup>	.71	2.95	1.57	6.02	4.17	.20	5.12	.98	6.97	3.94	6.57
<b>C712/C713</b>	14.37	11.22	14.76	11.81	9.25	9.25 <sup>1)</sup>	.71	3.54	1.97	7.28	5.00	.20	6.42	.98	7.56	4.72	7.91
<b>C812/C813</b>	17.13	14.17	17.72	13.39	11.81	11.42	.87	3.74	2.17	8.58	5.83	.39	7.48	1.14	8.78	5.51	8.70
<b>C912/C913</b>	20.08	16.14	20.87	15.75	13.39	13.39	1.02	4.33	2.36	10.08	7.01	.39	8.74	1.34	10.91	6.69	10.24

<sup>1)</sup> See Table No. 5

**Table No. 2 Metric output available on request**

Base Module	Standard Shaft - inches			Optional Shaft - mm		
	U	UA	UB	U	UA	UB
<b>C002</b>	.750	$\frac{3}{16} \times \frac{3}{16} \times \frac{17}{32}$	.83	20 <sub>k6</sub>	A6x6x32	22.5
<b>C102/C103</b>	1.000	$\frac{1}{4} \times \frac{1}{4} \times \frac{19}{16}$	1.11	25 <sub>k6</sub>	A8x7x40	28
<b>C202/C203</b>	1.250	$\frac{1}{4} \times \frac{1}{4} \times \frac{15}{16}$	1.36	30 <sub>k6</sub>	A8x7X50	33
<b>C302/C303</b>	1.250	$\frac{1}{4} \times \frac{1}{4} \times \frac{15}{16}$	1.36	30 <sub>k6</sub>	A8x7X50	33
<b>C402/C403</b>	1.625	$\frac{3}{8} \times \frac{3}{8} \times \frac{27}{8}$	1.79	40 <sub>k6</sub>	A12x8X70	43
<b>C502/C503</b>	1.625	$\frac{3}{8} \times \frac{3}{8} \times \frac{27}{8}$	1.79	40 <sub>k6</sub>	A12x8X70	43
<b>C612/C613</b>	2.125	$\frac{1}{2} \times \frac{1}{2} \times \frac{35}{32}$	2.35	50 <sub>k6</sub>	A14x9x90	53.5
<b>C712/C713</b>	2.375	$\frac{5}{8} \times \frac{5}{8} \times \frac{315}{16}$	2.65	60 <sub>m6</sub>	A18x11x100	64
<b>C812/C813</b>	2.875	$\frac{3}{4} \times \frac{3}{4} \times \frac{45}{16}$	3.21	70 <sub>m6</sub>	A20x12x125	74.5
<b>C912/C913</b>	3.625	$\frac{7}{8} \times \frac{7}{8} \times \frac{51}{2}$	4.01	90 <sub>m6</sub>	A25x14x140	95

**Table No. 3 Motor Adapter Dimensions (Inches)**

Motor Adapter	NEMA C-Flange	E	X	Y	YA	YB	YC	Wt. lbs.
<b>MR140/050</b>	56C	5.51	3.31	6.50	4.500	5.87	.41	9
<b>MR160/050</b>	56C	6.30	3.86	6.50	4.500	5.87	.41	16
<b>MR160/140</b>	143/145TC	6.30	3.86	6.50	4.500	5.87	.41	16
<b>MR200/180</b>	182/184TC	7.87	4.80	9.00	8.500	7.25	.55	23
<b>MR250/180</b>	182/184TC	9.84	5.31	9.00	8.500	7.25	.55	36
<b>MR250/210</b>	213/215TC	9.84	5.31	9.00	8.500	7.25	.55	36
<b>MR300/180</b>	182/184TC	11.81	6.50	9.00	8.500	7.25	.57	75
<b>MR300/210</b>	213/215TC	11.81	6.50	9.00	8.500	7.25	.57	75
<b>MR300/250</b>	254/256TC	11.81	6.50	9.00	8.500	7.25	.57	75
<b>MR300/280</b>	284/286TC	11.81	6.50	11.13	10.500	9.00	.57	75
<b>MR350/320</b>	324/326TC	13.78	7.09	13.37	12.500	11.00	.70	133
<b>MR350/360</b>	364/365TC	13.78	7.09	13.37	12.500	11.00	.70	133



# "C" Series – MGS Reducer Foot Mount – "N" Housing Dimensional Data

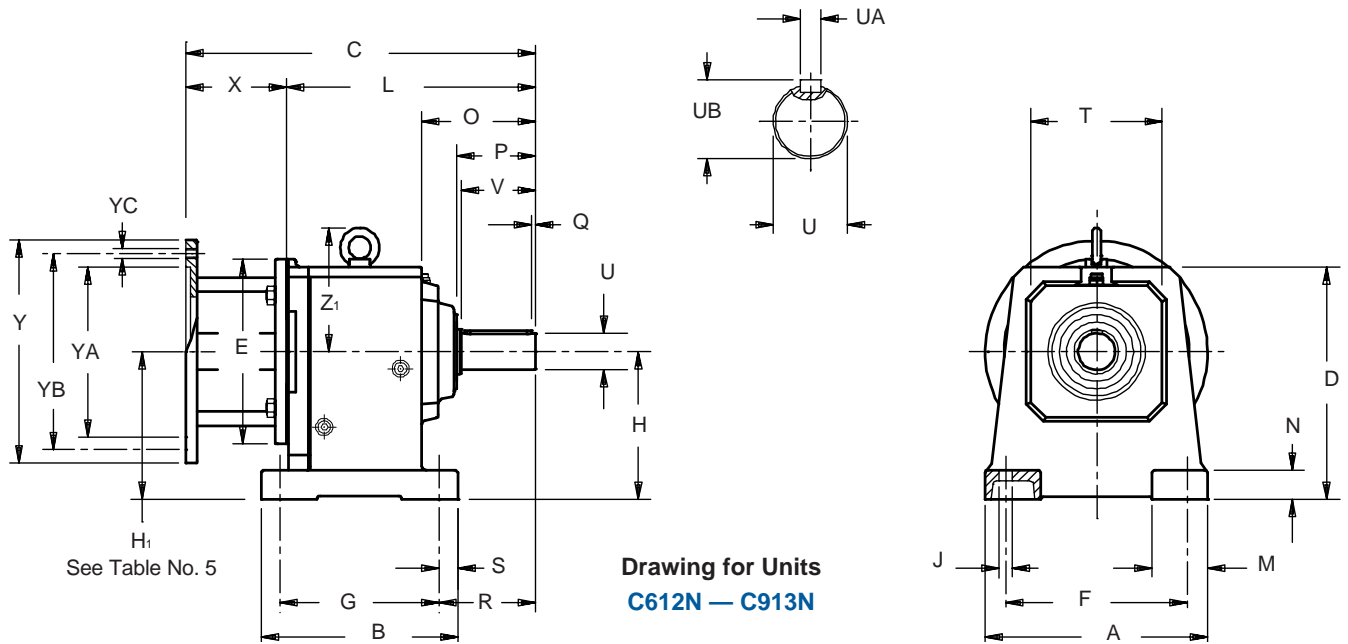
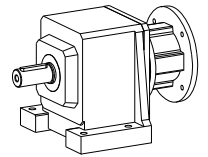

**Table No. 4 "C" Series – Foot Mounting Unit Dimensions (Inches) – "N" Housing Style**

Base Module	MR140/050		MR160/140 <sup>2)</sup>		MR200/180		MR250/210 <sup>3)</sup>		MR300/250 <sup>4)</sup>		MR350/320 <sup>5)</sup>		Approx. Wt.(lbs.)
	C	L	C	L	C	L	C	L	C	L	C	L	
C002	9.37	6.06	10.08	6.22	—	—	—	—	—	—	—	—	18
C102	10.67	7.36	11.38	7.52	12.40	7.60	—	—	—	—	—	—	29
C103	12.13	8.82	—	—	—	—	—	—	—	—	—	—	34
C202	11.77	8.46	12.48	8.62	13.50	8.70	—	—	—	—	—	—	38
C203	13.23	9.92	14.17	10.31	—	—	—	—	—	—	—	—	45
C302	—	—	13.23	9.37	14.25	9.45	14.88	9.57	—	—	—	—	49
C303 <sup>1)</sup>	13.98	10.67	14.92	11.06	—	—	—	—	—	—	—	—	56
C402	—	—	15.12	11.26	16.14	11.34	16.77	11.46	—	—	—	—	71
C403	—	—	16.81	12.95	—	—	—	—	—	—	—	—	78
C502	—	—	15.95	12.09	16.97	12.17	17.59	12.28	19.33	12.83	—	—	95
C503	—	—	17.64	13.78	—	—	—	—	—	—	—	—	111
C612 <sup>1)</sup>	—	—	—	—	17.91	13.11	18.54	13.23	20.24	13.74	—	—	115
C613 <sup>1)</sup>	—	—	18.62	14.76	20.35	15.55	—	—	—	—	—	—	159
C712	—	—	—	—	20.00	15.20	20.59	15.28	22.29	15.79	—	—	199
C713 <sup>1)</sup>	—	—	—	—	22.40	17.60	23.38	18.07	—	—	—	—	221
C812	—	—	—	—	—	—	23.22	17.91	24.53	18.03	26.42	19.33	322
C813	—	—	—	—	25.04	20.24	26.02	20.71	—	—	—	—	342
C912	—	—	—	—	—	—	—	—	27.56	21.06	29.06	21.97	596
C913	—	—	—	—	—	—	27.87	22.56	—	—	—	—	678

**Table No. 5 "C" Series – Input Dimension (Inches)**

Base Module	MR160/140 <sup>2)</sup>	MR200/180	MR250/210	MR300/250
	H <sub>1</sub>	H <sub>1</sub>	H <sub>1</sub>	H <sub>1</sub>
C303	3.66	—	—	—
C612	—	7.63	7.63	7.63
C613	—	—	7.63	—
C713	—	—	10.00	—

<sup>1)</sup> See Table No. 5

<sup>2)</sup> Also available as **MR160/050** for a NEMA 56C frame motor.

<sup>3)</sup> Also available as **MR250/180** for a NEMA 182/184TC frame motor.

<sup>4)</sup> Also available as **MR300/180** for a NEMA 182/184TC, **MR300/210** for a NEMA 213/215TC, and **MR300/280** for a NEMA 284/286TC frame motor.

<sup>5)</sup> Also available as **MR350/360** for a NEMA 364/365TC frame motor.

All weights are approximate.

**Part No. Example**

Foot Mounting with Motor Adapter

**C302N0620 MR160/140**



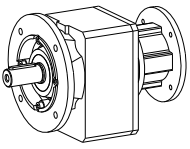

# "C" Series – MGS Reducer Round Flange – "F" Housing Dimensional Data

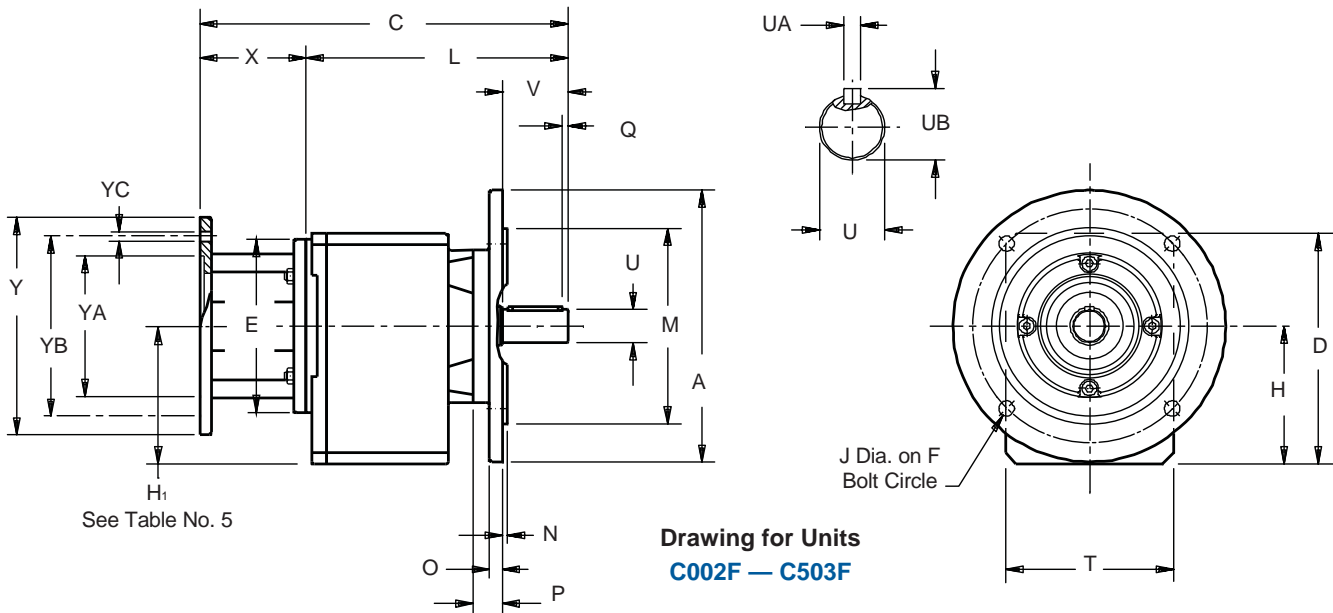

**Table No. 1 "C" Series – Round Flange Unit Dimensions (Inches) – "F" Housing Style**

Base Module	A	D	F	H	J	M	N	O	P	Q	T	V	Z <sub>1</sub>
<b>C002</b>	6.30	5.55	5.12	3.11	.35	4.331	.12	.39	.71	.16	3.82	1.57	—
<b>C102/C103</b>	7.87	6.89	6.50	3.94	.43	5.118	.14	.47	.83	.16	5.12	1.97	—
<b>C202/C203</b>	7.87	7.56	6.50	4.41	.43	5.118	.14	.47	1.06	.16	5.59	2.36	—
<b>C302/C303</b>	9.84	8.35	8.46	5.00 <sup>1)</sup>	.55	7.087	.16	.47	1.06	.16	6.06	2.36	—
<b>C402/C403</b>	9.84	9.55	8.46	5.61	.55	7.087	.16	.55	1.10	.16	7.01	3.15	—
<b>C502/C503</b>	11.81	11.26	10.43	6.54	.55	9.055	.16	.63	1.14	.16	7.68	3.15	—
<b>C612/C613</b>	11.81	11.97	10.43	7.44 <sup>1)</sup>	.55	9.055	.16	.67	1.42	.20	8.86	3.94	6.57
<b>C712/C713</b>	13.78	14.61	11.81	9.09 <sup>1)</sup>	.71	9.842	.20	.71	1.73	.20	10.43	4.72	7.91
<b>C812/C813</b>	15.75	17.52	13.78	11.22	.71	11.811	.20	.79	1.77	.39	12.20	5.51	8.70
<b>C912/C913</b>	17.72	20.63	15.75 *	13.15	.71	13.780	.20	.91	1.97	.39	14.37	6.69	10.24

<sup>1)</sup> See Table No. 5

\* C912 and C913 have 8 mounting holes in the output flange instead of 4 as shown in the drawing.

**Table No. 2 Metric output available on request**

Base Module	Standard Shaft - inches			Optional Shaft - mm		
	U	UA	UB	U	UA	UB
<b>C002</b>	.750	$\frac{3}{16} \times \frac{3}{16} \times 1\frac{7}{32}$	.83	20 <sub>k6</sub>	A6x6x32	22.5
<b>C102/C103</b>	1.000	$\frac{1}{4} \times \frac{1}{4} \times 1\frac{9}{16}$	1.11	25 <sub>k6</sub>	A8x7x40	28
<b>C202/C203</b>	1.250	$\frac{1}{4} \times \frac{1}{4} \times 1\frac{15}{16}$	1.36	30 <sub>k6</sub>	A8x7x50	33
<b>C302/C303</b>	1.250	$\frac{1}{4} \times \frac{1}{4} \times 1\frac{15}{16}$	1.36	30 <sub>k6</sub>	A8x7x50	33
<b>C402/C403</b>	1.625	$\frac{3}{8} \times \frac{3}{8} \times 2\frac{7}{8}$	1.79	40 <sub>k6</sub>	A12x8x70	43
<b>C502/C503</b>	1.625	$\frac{3}{8} \times \frac{3}{8} \times 2\frac{7}{8}$	1.79	40 <sub>k6</sub>	A12x8x70	43
<b>C612/C613</b>	2.125	$\frac{1}{2} \times \frac{1}{2} \times 3\frac{5}{32}$	2.35	50 <sub>k6</sub>	A14x9x90	53.5
<b>C712/C713</b>	2.375	$\frac{5}{8} \times \frac{5}{8} \times 3\frac{5}{16}$	2.65	60 <sub>m6</sub>	A18x11x100	64
<b>C812/C813</b>	2.875	$\frac{3}{4} \times \frac{3}{4} \times 4\frac{5}{16}$	3.21	70 <sub>m6</sub>	A20x12x125	74.5
<b>C912/C913</b>	3.625	$\frac{7}{8} \times \frac{7}{8} \times 5\frac{1}{2}$	4.01	90 <sub>m6</sub>	A25x14x140	95

**Table No. 3 Motor Adapter Dimensions (Inches)**

Motor Adapter	NEMA C-Flange	E	X	Y	YA	YB	YC	Wt. lbs.
<b>MR140/050</b>	56C	5.51	3.31	6.50	4.500	5.87	.41	9
<b>MR160/050</b>	56C	6.30	3.86	6.50	4.500	5.87	.41	16
<b>MR160/140</b>	143/145TC	6.30	3.86	6.50	4.500	5.87	.41	16
<b>MR200/180</b>	182/184TC	7.87	4.80	9.00	8.500	7.25	.55	23
<b>MR250/180</b>	182/184TC	9.84	5.31	9.00	8.500	7.25	.55	36
<b>MR250/210</b>	213/215TC	9.84	5.31	9.00	8.500	7.25	.55	36
<b>MR300/180</b>	182/184TC	11.81	6.50	9.00	8.500	7.25	.57	75
<b>MR300/210</b>	213/215TC	11.81	6.50	9.00	8.500	7.25	.57	75
<b>MR300/250</b>	254/256TC	11.81	6.50	9.00	8.500	7.25	.57	75
<b>MR300/280</b>	284/286TC	11.81	6.50	11.13	10.500	9.00	.57	75
<b>MR350/320</b>	324/326TC	13.78	7.09	13.37	12.500	11.00	.70	133
<b>MR350/360</b>	364/365TC	13.78	7.09	13.37	12.500	11.00	.70	133

**Part No. Example**  
Round Flange with Motor Adapter  
**C302F0620 MR160/140**



# "C" Series – MGS Reducer Round Flange – "F" Housing Dimensional Data

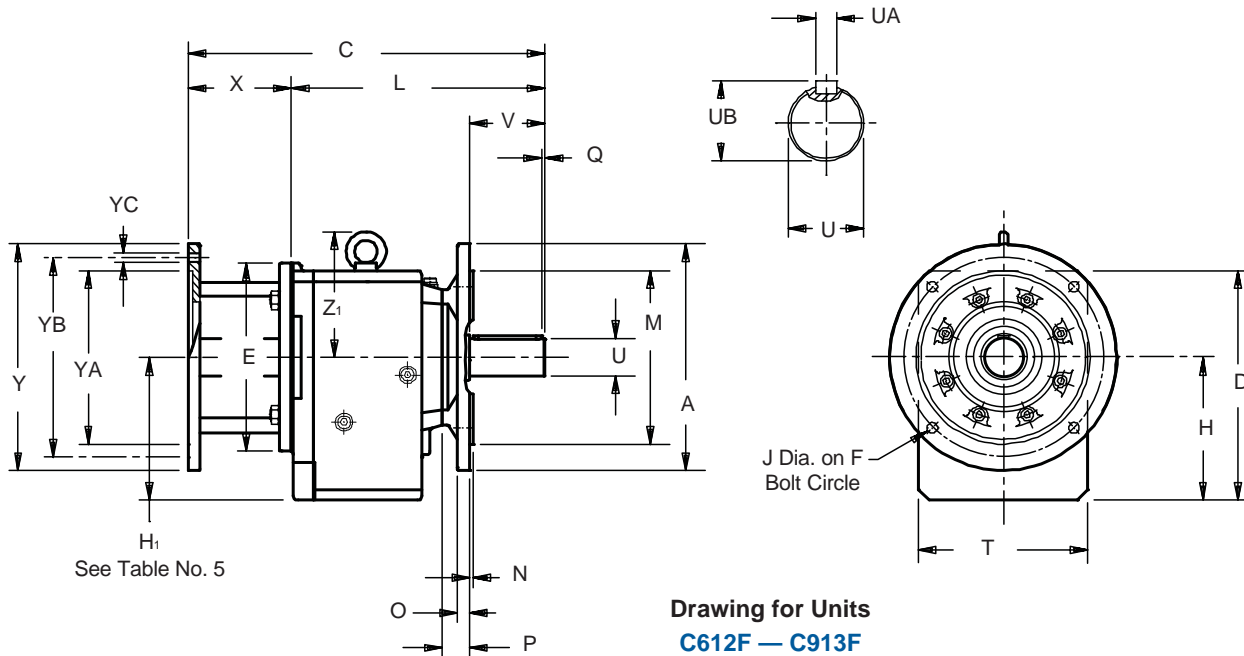
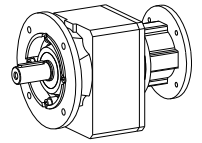

**Table No. 4 "C" Series – Round Flange Unit Dimensions (Inches) – "F" Housing Style**

Base Module	MR140/050		MR160/140 <sup>2)</sup>		MR200/180		MR250/210 <sup>3)</sup>		MR300/250 <sup>4)</sup>		MR350/320 <sup>5)</sup>		Approx. Wt. (lbs.)
	C	L	C	L	C	L	C	L	C	L	C	L	
C002	9.37	6.06	10.08	6.22	—	—	—	—	—	—	—	—	18
C102	10.67	7.36	11.38	7.52	12.40	7.60	—	—	—	—	—	—	29
C103	12.13	8.82	—	—	—	—	—	—	—	—	—	—	34
C202	11.77	8.46	12.48	8.62	13.50	8.70	—	—	—	—	—	—	38
C203	13.23	9.92	14.17	10.31	—	—	—	—	—	—	—	—	45
C302	—	—	13.23	9.37	14.25	9.45	14.88	9.57	—	—	—	—	49
C303 <sup>1)</sup>	13.98	10.67	14.92	11.06	—	—	—	—	—	—	—	—	56
C402	—	—	15.12	11.26	16.14	11.34	16.77	11.46	—	—	—	—	71
C403	—	—	16.81	12.95	—	—	—	—	—	—	—	—	78
C502	—	—	15.95	12.09	16.97	12.17	17.59	12.28	19.33	12.83	—	—	95
C503	—	—	17.64	13.78	—	—	—	—	—	—	—	—	111
C612 <sup>1)</sup>	—	—	—	—	17.91	13.11	18.54	13.23	20.24	13.74	—	—	115
C613 <sup>1)</sup>	—	—	18.62	14.76	20.35	15.55	—	—	—	—	—	—	159
C712	—	—	—	—	20.00	15.20	20.59	15.28	22.29	15.79	—	—	199
C71 <sup>1)</sup>	—	—	—	—	22.40	17.60	23.38	18.07	—	—	—	—	221
C812	—	—	—	—	—	—	23.22	17.91	24.53	18.03	26.42	19.33	322
C813	—	—	—	—	25.04	20.24	26.02	20.71	—	—	—	—	342
C912	—	—	—	—	—	—	—	—	27.56	21.06	29.06	21.97	596
C913	—	—	—	—	—	—	27.87	22.56	—	—	—	—	678

**Table No. 5 "C" Series – Input Dimension (Inches)**

Base Module	MR160/140 <sup>2)</sup>	MR200/180	MR250/210	MR300/250
	H <sub>1</sub>	H <sub>1</sub>	H <sub>1</sub>	H <sub>1</sub>
C303	3.54	—	—	—
C612	—	7.44	7.44	7.44
C613	—	—	7.44	—
C713	—	—	9.84	—

**Table No. 6 Optional Flange Dimensions (Inches)**

Base Module	Flange Size	A	F	J	M	N	O
		C0	120	4.724	3.93	.28	3.150 +.001/-0.004
	140	5.512	4.53	.35	3.740 +.001/-0.004	.12	.39
C1	140	5.512	4.53	.35	3.740 +.001/-0.004	.14	.32
	160	6.300	5.12	.35	4.331 +.001/-0.004	.14	.39
C2	160	6.300	5.12	.35	4.331 +.001/-0.004	.14	.39
	250	9.843	8.46	.55	7.087 +.001/-0.004	.16	.47
C3	160	6.300	5.12	.35	4.331 +.001/-0.004	.14	.39
	200	7.874	6.50	.43	5.118 +.001/-0.004	.14	.47
C4	200	7.874	6.50	.43	5.118 +.001/-0.004	.16	.55
	300	11.811	10.43	.55	9.055 +.001/-0.001	.16	.55
C5	250	9.843	8.46	.55	7.087 +.001/-0.004	.16	.55
C8	350	13.780	11.81	.71	9.842 +.000/-0.001	.20	.71
	450	17.717	15.75	.71	13.780 +.000/-0.001	.20	.79

<sup>1)</sup> See Table No. 5  
<sup>2)</sup> Also available as MR160/050 for a NEMA 56C frame motor.  
<sup>3)</sup> Also available as MR250/180 for a NEMA 182/184TC frame motor.  
<sup>4)</sup> Also available as MR300/180 for a NEMA 182/184TC, MR300/210 for a NEMA 213/215TC, and MR300/280 for a NEMA 284/286TC frame motor.  
<sup>5)</sup> Also available as MR350/360 for a NEMA 364/365TC frame motor.  
 All weights are approximate.

Optional flanges are not available for all sizes.



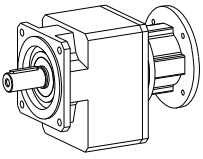

# "C" Series – MGS Reducer Square Flange – "Q" Housing Dimensional Data

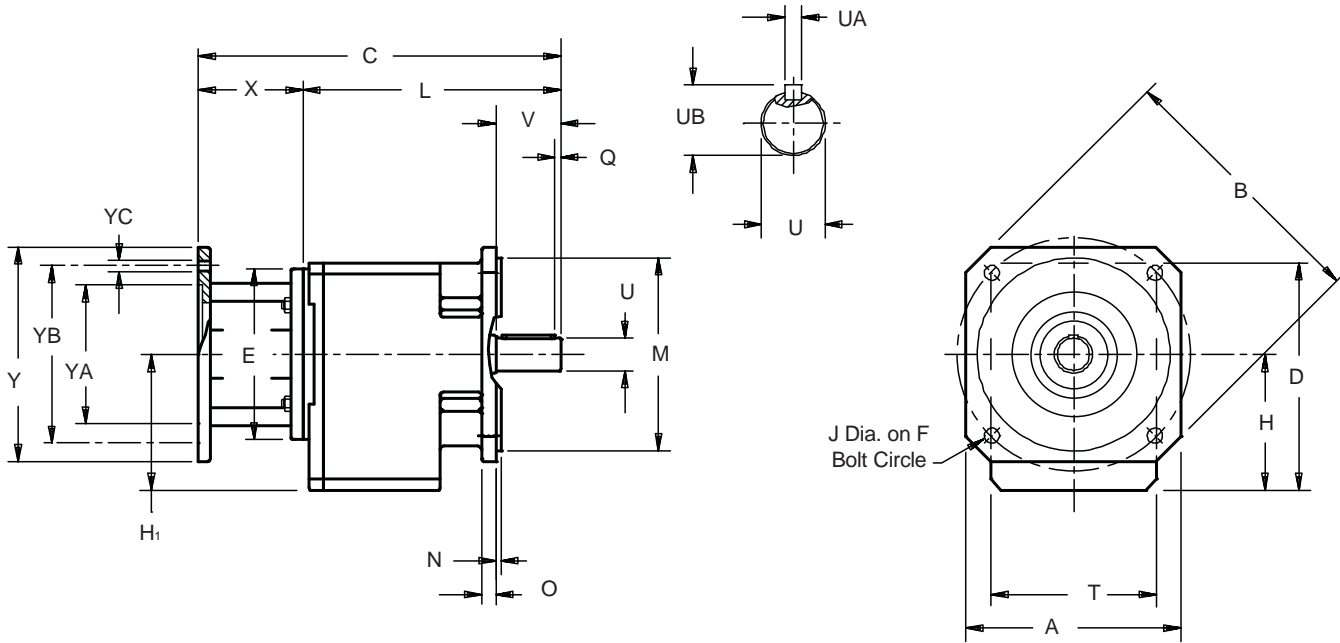

Drawing for Units  
C002Q – C403Q

Table No. 1 "C" Series – Square Flange Unit Dimensions (Inches) – "Q" Housing Style

Base Module	A	B	D	F	H	J	M	N	O	Q	T	V
<b>C002</b>	4.88	6.30	5.55	5.12	3.11	.35	4.33	.14	.35	.16	3.82	1.57
<b>C102/C103</b>	5.71	7.56	6.89	6.50	3.94	.43	5.12	.14	.43	.16	5.12	1.97
<b>C202/C203</b>	5.71	7.56	7.56	6.50	4.41	.43	5.12	.14	.43	.16	5.59	2.36
<b>C302/C303</b>	7.87	9.84	8.35	8.46	5.00 <sup>1)</sup>	.55	7.09	.16	.55	.16	6.06	2.36
<b>C402/C403</b>	7.87	9.84	9.55	8.46	5.61	.55	7.09	.16	.55	.16	7.01	3.15

<sup>1)</sup> H<sub>1</sub> dimension is 3.54 on C303.

Table No. 2 Metric output available on request

Base Module	Standard Shaft - inches			Optional Shaft - mm		
	U	UA	UB	U	UA	UB
<b>C002</b>	.750	$\frac{3}{16} \times \frac{3}{16} \times \frac{17}{32}$	.83	20 <sub>k6</sub>	A6x6x32	22.5
<b>C102/C103</b>	1.000	$\frac{1}{4} \times \frac{1}{4} \times \frac{19}{16}$	1.11	25 <sub>k6</sub>	A8x7x40	28
<b>C202/C203</b>	1.250	$\frac{1}{4} \times \frac{1}{4} \times \frac{1^{15}}{16}$	1.36	30 <sub>k6</sub>	A8x7x50	33
<b>C302/C303</b>	1.250	$\frac{1}{4} \times \frac{1}{4} \times \frac{1^{15}}{16}$	1.36	30 <sub>k6</sub>	A8x7x50	33
<b>C402/C403</b>	1.625	$\frac{3}{8} \times \frac{3}{8} \times \frac{27}{8}$	1.79	40 <sub>k6</sub>	A12x8x70	43

This Housing Style is available on special order.



# "C" Series – MGS Reducer Square Flange – "Q" Housing Dimensional Data

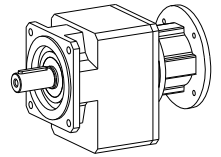

**Table No. 3 Motor Adapter Dimensions (Inches)**

Motor Adapter	NEMA C-Flange	E	X	Y	YA	YB	YC	Wt. lbs.
<b>MR140/050</b>	56C	5.51	3.31	6.50	4.500	5.87	.41	9
<b>MR160/050</b>	56C	6.30	3.86	6.50	4.500	5.87	.41	16
<b>MR160/140</b>	143/145TC	6.30	3.86	6.50	4.500	5.87	.41	16
<b>MR200/180</b>	182/184TC	7.87	4.80	9.00	8.500	7.25	.55	23
<b>MR250/180</b>	182/184TC	9.84	5.31	9.00	8.500	7.25	.55	36
<b>MR250/210</b>	213/215TC	9.84	5.31	9.00	8.500	7.25	.55	36

**Table No. 4 "C" Series – Unit Dimensions (Inches) – "Q" Housing Style**

Base Module	<b>MR140/050</b>		<b>MR160/140</b> <sup>2)</sup>		<b>MR200/180</b>		<b>MR250/210</b> <sup>3)</sup>		Approx. Wt.(lbs.)
	C	L	C	L	C	L	C	L	
<b>C002</b>	9.37	6.06	10.08	6.22	—	—	—	—	18
<b>C102</b>	10.67	7.36	11.38	7.52	12.40	7.60	—	—	29
<b>C103</b>	12.13	8.82	—	—	—	—	—	—	34
<b>C202</b>	11.77	8.46	12.48	8.62	13.50	8.70	—	—	38
<b>C203</b>	13.23	9.92	14.17	10.31	—	—	—	—	45
<b>C302</b>	—	—	13.23	9.37	14.25	9.45	14.88	9.57	49
<b>C303</b> <sup>1)</sup>	13.98	10.67	14.92	11.06	—	—	—	—	56
<b>C402</b>	—	—	15.12	11.26	16.14	11.34	16.77	11.46	71
<b>C403</b>	—	—	16.81	12.95	—	—	—	—	78

<sup>2)</sup> Also available as **MR160/050** for a NEMA 56C frame motor.

<sup>3)</sup> Also available as **MR250/180** for a NEMA 182/184TC frame motor.

All weights are approximate.

**Part No. Example**  
Square Flange with Motor Adapter  
**C302Q0620 MR160/140**

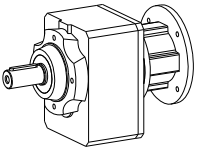

# "C" Series – MGS Reducer Tapped Holes – "G" Housing Dimensional Data

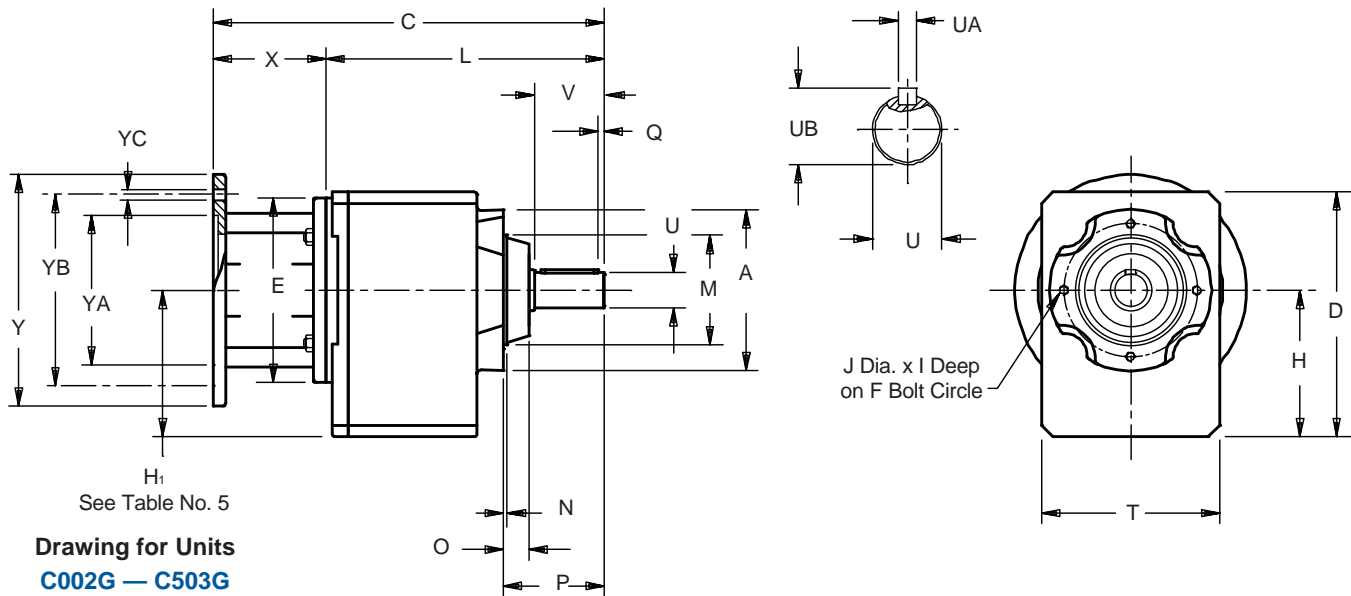

H<sub>1</sub>  
See Table No. 5

Drawing for Units  
C002G – C503G

**Table No. 1 "C" Series – Tapped Holes Unit Dimensions (Inches) – "G" Housing Style**

Base Module	A	D	F	H	I	J	M	N	O	P	Q	T	V	Z <sub>1</sub>
<b>C002</b>	3.43	5.55	2.95	3.11	.39	M6	2.165	.12	.55	2.28	.16	3.82	1.57	—
<b>C102/C103</b>	4.72	6.89	3.94	3.94	.51	M6	3.150	.12	.67	2.80	.16	5.12	1.97	—
<b>C202/C203</b>	5.51	7.56	4.53	4.41	.51	M8	3.740	.12	.87	3.43	.16	5.59	2.36	—
<b>C302/C303</b>	5.51	8.35	4.53	5.00 <sup>1)</sup>	.51	M8	3.740	.12	.87	3.43	.16	6.06	2.36	—
<b>C402/C403</b>	6.30	9.55	5.12	5.61	.63	M10	4.331	.14	.87	4.25	.16	7.01	3.15	—
<b>C502/C503</b>	7.56	11.26	6.50 <sup>2)</sup>	6.54	.63	M10	5.118	.14	.91	4.29	.16	7.68	3.15	—
<b>C612/C613</b>	7.09	11.97	6.50	7.44 <sup>1)</sup>	.63	M10	5.512	.20	1.18	5.35	.20	8.86	3.94	6.57
<b>C712/C713</b>	7.68	14.61	7.28	9.09 <sup>1)</sup>	.75	M12	6.102	.31	1.46	6.46	.20	10.43	4.72	7.91
<b>C812/C813</b>	8.90	17.52	8.46	11.22	.75	M12	7.283	.20	1.46	7.28	.39	12.20	5.51	8.70
<b>C912/C913</b>	11.02	20.63	10.43	13.15	1.02	M16	9.055	.20	1.65	8.66	.39	14.37	6.69	10.24

<sup>1)</sup> See Table No. 5

<sup>2)</sup> C502/C503 has 8 holes instead of 4 as shown in the drawing.

**Table No. 2 Metric output available on request**

Base Module	Standard Shaft - inches			Optional Shaft - mm		
	U	UA	UB	U	UA	UB
<b>C002</b>	.750	3/16 x 3/16 x 17/32	.83	20 <sub>k6</sub>	A6x6x32	22.5
<b>C102/C103</b>	1.000	1/4 x 1/4 x 19/16	1.11	25 <sub>k6</sub>	A8x7x40	28
<b>C202/C203</b>	1.250	1/4 x 1/4 x 115/16	1.36	30 <sub>k6</sub>	A8x7X50	33
<b>C302/C303</b>	1.250	1/4 x 1/4 x 115/16	1.36	30 <sub>k6</sub>	A8x7X50	33
<b>C402/C403</b>	1.625	3/8 x 3/8 x 27/8	1.79	40 <sub>k6</sub>	A12x8X70	43
<b>C502/C503</b>	1.625	3/8 x 3/8 x 27/8	1.79	40 <sub>k6</sub>	A12x8X70	43
<b>C612/C613</b>	2.125	1/2 x 1/2 x 35/32	2.35	50 <sub>k6</sub>	A14x9x90	53.5
<b>C712/C713</b>	2.375	5/8 x 5/8 x 315/16	2.65	60 <sub>m6</sub>	A18x11x100	64
<b>C812/C813</b>	2.875	3/4 x 3/4 x 45/16	3.21	70 <sub>m6</sub>	A20x12x125	74.5
<b>C912/C913</b>	3.625	7/8 x 7/8 x 51/2	4.01	90 <sub>m6</sub>	A25x14x140	95

**Table No. 3 Motor Adapter Dimensions (Inches)**

Motor Adapter	NEMA C-Flange	E	X	Y	YA	YB	YC	Wt. lbs.
<b>MR140/050</b>	56C	5.51	3.31	6.50	4.500	5.87	.41	9
<b>MR160/050</b>	56C	6.30	3.86	6.50	4.500	5.87	.41	16
<b>MR160/140</b>	143/145TC	6.30	3.86	6.50	4.500	5.87	.41	16
<b>MR200/180</b>	182/184TC	7.87	4.80	9.00	8.500	7.25	.55	23
<b>MR250/180</b>	182/184TC	9.84	5.31	9.00	8.500	7.25	.55	36
<b>MR250/210</b>	213/215TC	9.84	5.31	9.00	8.500	7.25	.55	36
<b>MR300/180</b>	182/184TC	11.81	6.50	9.00	8.500	7.25	.57	75
<b>MR300/210</b>	213/215TC	11.81	6.50	9.00	8.500	7.25	.57	75
<b>MR300/250</b>	254/256TC	11.81	6.50	9.00	8.500	7.25	.57	75
<b>MR300/280</b>	284/286TC	11.81	6.50	11.13	10.500	9.00	.57	75
<b>MR350/320</b>	324/326TC	13.78	7.09	13.37	12.500	11.00	.70	133
<b>MR350/360</b>	364/365TC	13.78	7.09	13.37	12.500	11.00	.70	133





# "C" Series – MGS Reducer Tapped Holes – "G" Housing Dimensional Data

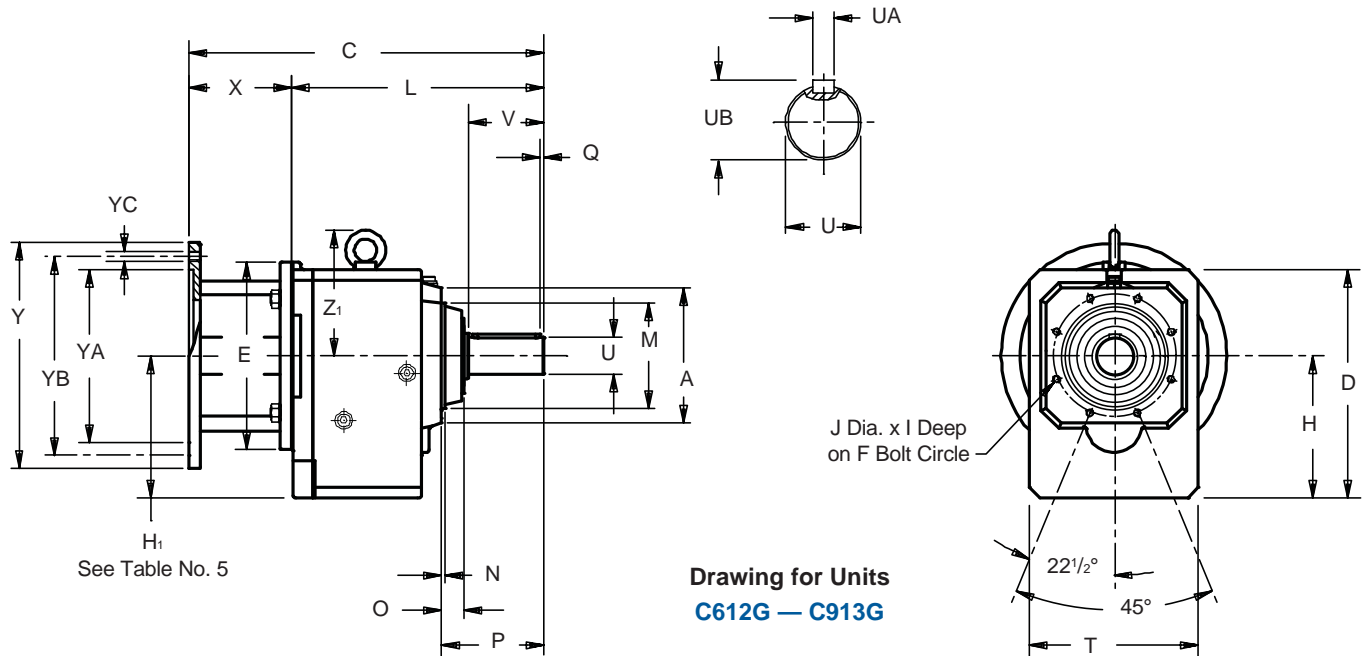
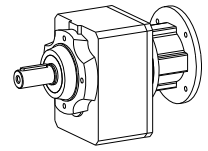

**Table No. 4 "C" Series – Tapped Holes Unit Dimensions (Inches) – "G" Housing Style**

Base Module	MR140/050		MR160/140 <sup>3)</sup>		MR200/180		MR250/210 <sup>4)</sup>		MR300/250 <sup>5)</sup>		MR350/320 <sup>6)</sup>		Approx. Wt. (lbs)
	C	L	C	L	C	L	C	L	C	L	C	L	
C002	9.37	6.06	10.08	6.22	—	—	—	—	—	—	—	—	18
C102	10.67	7.36	11.38	7.52	12.40	7.60	—	—	—	—	—	—	29
C103	12.13	8.82	—	—	—	—	—	—	—	—	—	—	34
C202	11.77	8.46	12.48	8.62	13.50	8.70	—	—	—	—	—	—	38
C203	13.23	9.92	14.17	10.31	—	—	—	—	—	—	—	—	45
C302	—	—	13.23	9.37	14.25	9.45	14.88	9.57	—	—	—	—	49
C303 <sup>1)</sup>	13.98	10.67	14.92	11.06	—	—	—	—	—	—	—	—	56
C402	—	—	15.12	11.26	16.14	11.34	16.77	11.46	—	—	—	—	71
C403	—	—	16.81	12.95	—	—	—	—	—	—	—	—	78
C502	—	—	15.95	12.09	16.97	12.17	17.59	12.28	19.33	12.83	—	—	95
C503	—	—	17.64	13.78	—	—	—	—	—	—	—	—	111
C612 <sup>1)</sup>	—	—	—	—	17.91	13.11	18.54	13.23	20.24	13.74	—	—	115
C613 <sup>1)</sup>	—	—	18.62	14.76	20.35	15.55	—	—	—	—	—	—	159
C712	—	—	—	—	20.00	15.20	20.59	15.28	22.29	15.79	—	—	199
C713 <sup>1)</sup>	—	—	—	—	22.40	17.60	23.38	18.07	—	—	—	—	221
C812	—	—	—	—	—	—	23.22	17.91	24.53	18.03	26.42	19.33	322
C813	—	—	—	—	25.04	20.24	26.02	20.71	—	—	—	—	342
C912	—	—	—	—	—	—	—	—	27.56	21.06	29.06	21.97	596
C913	—	—	—	—	—	—	27.87	22.56	—	—	—	—	678

**Table No. 5 "C" Series – Input Dimension (Inches)**

Base Module	MR160/140	MR200/180	MR250/210	MR300/250
	H <sub>1</sub>	H <sub>1</sub>	H <sub>1</sub>	H <sub>1</sub>
C303	3.54	—	—	—
C612	—	7.44	7.44	7.44
C613	—	—	7.44	—
C713	—	—	9.84	—

<sup>1)</sup> See Table No. 5

<sup>3)</sup> Also available as **MR160/050** for a NEMA 56C frame motor.

<sup>4)</sup> Also available as **MR250/180** for a NEMA 182/184TC frame motor.

<sup>5)</sup> Also available as **MR300/180** for a NEMA 182/184TC, **MR300/210** for a NEMA 213/215TC, and **MR300/280** for a NEMA 284/286TC frame motor.

<sup>6)</sup> Also available as **MR350/360** for a NEMA 364/365TC frame motor.

All weights are approximate.

**Part No. Example**

Tapped Holes Housing with Motor Adapter

**C302G0620 MR160/140**



# **“F” Series Offset Helical Speed Reducers**

**3 YEAR WARRANTY STANDARD**



**5 YEAR WARRANTY OPTIONAL**

**3-DAY  
DELIVERY**



[www.stober.com](http://www.stober.com)

**INDUSTRIAL MAGZA**  
DIST. AUTORIZADO

MEX (55) 53 63 23 31    MTY (81) 83 54 10 18  
QRO (442) 1 95 72 60    [ventas@industrialmagza.com](mailto:ventas@industrialmagza.com)

# "F" Series – Offset Helical MGS Speed Reducers



Compact size and flexibility make these gear drives a popular choice for applications that require high performance, efficiency, and durability. Series "F" gear drives are available with a wide selection of exact ratios and output speeds to eliminate the need for expensive and maintenance prone external input drives. It's a compact package that reduces product and installation costs today— and maintenance costs tomorrow.

### Performance Specifications:

- Horsepower ratings from 1/6 to 33
- Output torques to 9,743 in. lbs.
- Output speeds available from 406 to 3 RPM
- Speed reducer ratios from 4.3:1 to 552:1
- 3 year warranty – your assurance of satisfactory product performance

### Input Options:

- Input shaft
- NEMA C-face Adapter (coupling type)

Strategically located oil fill, drain and breather ports for optimum mounting flexibility. Oil sight glass available.

Stainless steel nameplate and hardware

One-piece cast iron housing with precision machined bearing supports assure gearset alignment, prolongs bearing life, provides exceptional overhung load capacities, and eliminates leakage problems common to two-piece housings.

High quality helical gearing is case hardened to 58-62 Rockwell C. Precision finished for low noise and long service life. Standard backlash is  $\leq 11$  arc minutes

Double lip seals keep oil in and contaminants out. Double seals available for severe duty applications.

### Output Options:

- Solid shaft
- Hollow
- Wobble free bushings

**STANDARD  
3-DAY  
DELIVERY**

Shipped with the proper amount and type of oil to prevent gear damaging dry start-ups



MEX (55) 53 63 23 31 MTY (81) 83 54 10 18  
QRO (442) 1 95 72 60 ventas@industrialmagza.com

STOBER Drives Inc. • MGS2007 • [www.stober.com](http://www.stober.com)





# "F" Series – Offset Helical MGS Speed Reducers Overview

## Output Style + Housing Style + Input Style = Reducer Configurations



## Reducer Configurations (See Page 170 for AW Input Shaft.)



## Mounting Positions – Standard 3 Year Warranty

Mounting Positions **MUST BE SPECIFIED.** (See Page 180 for more details.)

Standard Oil: Mobile XP600

Optional Oil: Food Grade Oil (Exxon Univis Special Mist 220)

Synthetic Oil (Mobil SHC630)

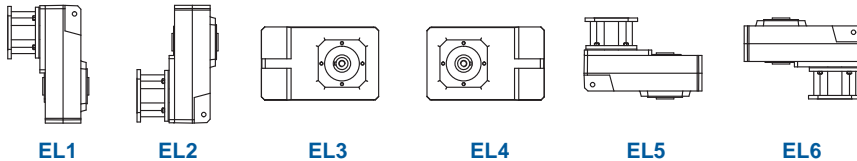

## Mounting Positions – Long Life 5 Year Warranty

Mounting Positions **MUST BE SPECIFIED.** (See Page 180 for more details.)

Standard Oil: Synthetic Oil (Mobil SHC630)

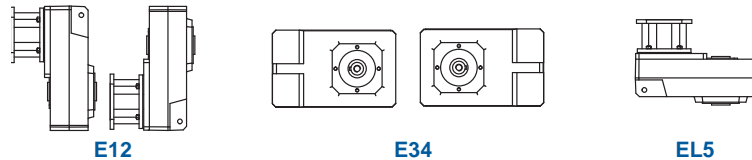

## Part No. Explanation with OPTIONS

**F 4 0 2 V F 0135 MR200/ 180 LL E12**

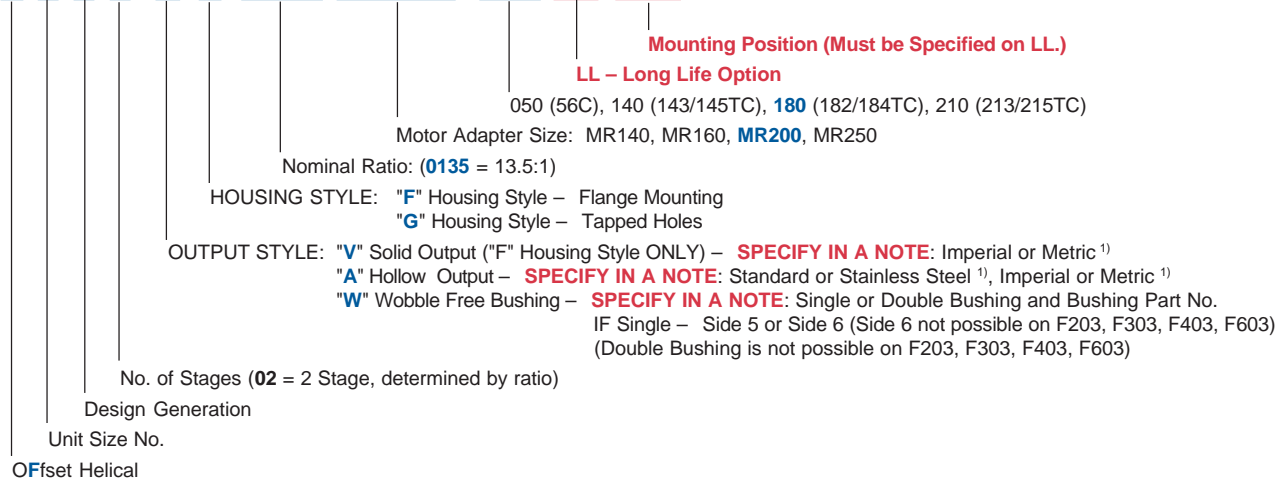

### THE FOLLOWING INFORMATION IS REQUIRED FOR ANY UNIT:

- Mounting Position – EL1 EL2 EL3 EL4 EL5 EL6 E12 E34
- Paint – Standard Gray, White, Stainless Steel
- <sup>1)</sup> – Not available in all sizes.





# "F" Series – Offset Helical MGS Reducer – Selection Data



### Selection Procedure:

- Under the Input RPM heading, find **Approximate Output RPM** nearest the requirement.
- In the **Input HP** column locate the rating that is greater than or equal to the required HP.  
(If selection is based on Torque instead of HP, find an **Output Torque** that is equal to or greater than required.)
- When HP or Torque rating is located, read across that row to select the **Base Module**, **Input Option** and **Overhung Loads**.
- If exact **Output RPM** is required, divide the **Input RPM** by the **Exact Ratio**.

1750 RPM Input		Base Module <sup>1)</sup>	Input Options <sup>2)</sup>			Exact Ratio	Overhung Load Output Shaft <sup>3)</sup> lbs.	1450 RPM Input		1160 RPM Input		870 RPM Input	
Input HP	Output Torque in. lbs.		Motor Adapter	NEMA C-Frame Size <sup>4)</sup>	Input Shaft			Input HP	Output Torque in. lbs.	Input HP	Output Torque in. lbs.	Input HP	Output Torque in. lbs.
<b>405 RPM Output (Approximate)</b>													
<b>330 RPM      270 RPM      200 RPM</b>													
2.64	398	F102_0043	MR140/050	56C	AW140/010	4.308	374	2.19	398	1.75	398	1.31	398
3.75*	564	F102_0043	MR160/050	56C	AW160/012	4.308	374	3.30	600	2.85	647	2.35	712
3.75*	564	F102_0043	MR160/140	143/145TC	AW160/012	4.308	374	3.30	600	2.85	647	2.35	712
<b>385 RPM Output (Approximate)</b>													
<b>315 RPM      255 RPM      190 RPM</b>													
23.36*	3,711	F602_0045	MR200/180	182/184/TC	AW200/014	4.546	1,129	19.36	3,711	15.48	3,711	11.61	3,711
33.04*	5,249	F602_0045	MR250/180	182/184/TC	AW250/102	4.546	1,129	29.14	5,586	23.31	5,586	17.48	5,586
<b>375 RPM Output (Approximate)</b>													
<b>305 RPM      250 RPM      185 RPM</b>													
2.78	454	F202_0047	MR140/050	56C	AW140/010	4.680	491	2.30	454	1.84	454	1.38	454
7.05*	1,154	F202_0047	MR160/050	56C	AW160/012	4.680	491	6.22	1,228	5.36	1,323	4.43	1,456
7.05*	1,154	F202_0047	MR160/140	143/145TC	AW160/012	4.680	491	6.22	1,228	5.36	1,323	4.43	1,456
7.05*	1,154	F202_0047	MR200/180	182/184/TC	AW200/014	4.680	491	6.22	1,228	5.36	1,323	4.43	1,456
9.84*	1,596	F302_0046	MR160/050	56C	AW160/012	4.644	681	8.15	1,596	6.52	1,596	4.89	1,596
9.84*	1,596	F302_0046	MR160/140	143/145TC	AW160/012	4.644	681	8.15	1,596	6.52	1,596	4.89	1,596
9.84	1,608	F402_0047	MR160/050	56C	AW160/012	4.678	842	8.15	1,608	6.52	1,608	4.89	1,608
9.84	1,608	F402_0047	MR160/140	143/145TC	AW160/012	4.678	842	8.15	1,608	6.52	1,608	4.89	1,608
11.80*	1,915	F302_0046	MR200/180	182/184/TC	AW200/014	4.644	681	10.41	2,039	8.97	2,196	7.41	2,417
19.40*	3,171	F402_0047	MR200/180	182/184/TC	AW200/014	4.678	842	17.11	3,376	14.75	3,636	11.61	3,818
19.40*	3,171	F402_0047	MR250/180	182/184/TC	AW250/102	4.678	842	17.11	3,376	14.75	3,636	12.17	4,002
<b>315 RPM Output (Approximate)</b>													
<b>255 RPM      210 RPM      155 RPM</b>													
6.30*	1,221	F202_0056	MR160/050	56C	AW160/012	5.552	513	5.55	1,300	4.79	1,401	3.95	1,542
6.30*	1,221	F202_0056	MR160/140	143/145TC	AW160/012	5.552	513	5.55	1,300	4.79	1,401	3.95	1,542
6.30*	1,221	F202_0056	MR200/180	182/184/TC	AW200/014	5.552	513	5.55	1,300	4.79	1,401	3.95	1,542
<b>305 RPM Output (Approximate)</b>													
<b>250 RPM      200 RPM      150 RPM</b>													
9.84*	1,966	F302_0057	MR160/050	56C	AW160/012	5.720	718	8.15	1,966	6.52	1,966	4.89	1,966
9.84*	1,966	F302_0057	MR160/140	143/145TC	AW160/012	5.720	718	8.15	1,966	6.52	1,966	4.89	1,966
9.84	1,998	F402_0058	MR160/050	56C	AW160/012	5.813	889	8.15	1,998	6.52	1,998	4.89	1,998
9.84	1,998	F402_0058	MR160/140	143/145TC	AW160/012	5.813	889	8.15	1,998	6.52	1,998	4.89	1,998
10.27*	2,053	F302_0057	MR200/180	182/184/TC	AW200/014	5.720	718	9.06	2,186	7.81	2,354	6.14	2,467
16.78*	3,409	F402_0058	MR200/180	182/184/TC	AW200/014	5.813	889	14.80	3,629	12.76	3,910	10.53	4,303
16.78*	3,409	F402_0058	MR250/180	182/184/TC	AW250/102	5.813	889	14.80	3,629	12.76	3,910	10.53	4,303
23.36*	4,631	F602_0057	MR200/180	182/184/TC	AW200/014	5.673	1,193	19.36	4,631	15.48	4,631	11.61	4,631
28.51*	5,651	F602_0057	MR250/210	213/215/TC	AW250/102	5.673	1,193	25.15	6,016	21.67	6,481	17.02	6,788
<b>270 RPM Output (Approximate)</b>													
<b>220 RPM      180 RPM      135 RPM</b>													
2.50	564	F102_0065	MR140/050	56C	AW140/010	6.462	414	2.07	564	1.66	564	1.24	564
2.86	646	F102_0065	MR160/050	56C	AW160/012	6.462	414	2.52	687	2.17	740	1.79	815
2.86	646	F102_0065	MR160/140	143/145TC	AW160/012	6.462	414	2.52	687	2.17	740	1.79	815

\* For thermal HP capacity, see rating below.

Base Module	F1	F2	F3	F4	F6
Thermal Capacity	2.95	5.36	7.38	12.34	14.75

NEMA Frame Size  
TEFC 1750 RPM

C-Frame	Motor HP
56C	1/3 - 1/2
143/145TC	1, 1 1/2, 2
182/184TC	3, 5
213/215TC	7 1/2, 10

### Housing Styles

F – Round Flange

G – Tapped Holes

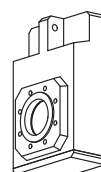
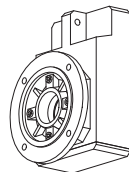

Some Housing Styles are available as Hollow (A) or Solid (V) Output.



# "F" Series – Offset Helical MGS Reducer – Selection Data



- NOTE:**
- 1) Complete Base Module Part Number by adding Output and Housing Style. Example: F302AG0560.
  - 2) Select Input Option and add to completed Part Number. See example below.
  - 3) Overhung Load is measured at the center of the shaft extension. Hollow output units are not intended to support overhung loads. If a load rating is required, use 50% of the published overhung load.
  - 4) Other frame sizes may also be available. See dimension pages.

1750 RPM Input		Base Module <sup>1)</sup>	Input Options <sup>2)</sup>			Exact Ratio	Overhung Load Output Shaft <sup>3)</sup> lbs.	1450 RPM Input		1160 RPM Input		870 RPM Input	
Input HP	Output Torque in. lbs.		Motor Adapter	NEMA C-Frame Size <sup>4)</sup>	Input Shaft			Input HP	Output Torque in. lbs.	Input HP	Output Torque in. lbs.	Input HP	Output Torque in. lbs.
<b>245 RPM Output (Approximate)</b>													
2.46	615	F102_0072	MR140/050	56C	AW140/010	7.156	425	2.04	615	1.63	615	1.22	615
2.61	654	F202_0072	MR140/050	56C	AW140/010	7.167	547	2.16	654	1.73	654	1.30	654
2.67	668	F102_0072	MR160/050	56C	AW160/012	7.156	425	2.36	711	2.03	766	1.68	843
2.67	668	F102_0072	MR160/140	143/145TC	AW160/012	7.156	425	2.36	711	2.03	766	1.68	843
5.31	1,330	F202_0072	MR160/050	56C	AW160/012	7.167	547	4.68	1,416	4.04	1,525	3.33	1,679
5.31	1,330	F202_0072	MR160/140	143/145TC	AW160/012	7.167	547	4.68	1,416	4.04	1,525	3.33	1,679
5.31	1,330	F202_0072	MR200/180	182/184/TC	AW200/014	7.167	547	4.68	1,416	4.04	1,525	3.33	1,679
8.83*	2,214	F302_0072	MR160/050	56C	AW160/012	7.172	759	7.79	2,357	6.52	2,465	4.89	2,465
8.83*	2,214	F302_0072	MR160/140	143/145TC	AW160/012	7.172	759	7.79	2,357	6.52	2,465	4.89	2,465
8.83*	2,214	F302_0072	MR200/180	182/184/TC	AW200/014	7.172	759	7.79	2,357	6.72	2,539	5.54	2,794
9.84	2,475	F402_0072	MR160/050	56C	AW160/012	7.202	937	8.15	2,475	6.52	2,475	4.89	2,475
9.84	2,475	F402_0072	MR160/140	143/145TC	AW160/012	7.202	937	8.15	2,475	6.52	2,475	4.89	2,475
14.55*	3,661	F402_0072	MR200/180	182/184/TC	AW200/014	7.202	937	12.83	3,898	11.06	4,199	9.13	4,622
14.55*	3,661	F402_0072	MR250/180	182/184/TC	AW250/102	7.202	937	12.83	3,898	11.06	4,199	9.13	4,622
23.36*	5,844	F602_0072	MR200/180	182/184/TC	AW200/014	7.159	1,265	19.36	5,844	15.48	5,844	11.61	5,844
24.41*	6,106	F602_0072	MR250/180	182/184/TC	AW250/102	7.159	1,265	21.53	6,501	18.56	7,003	15.32	7,708
<b>195 RPM Output (Approximate)</b>													
2.30	720	F102_0089	MR140/050	56C	AW140/010	8.948	449	1.97	742	1.57	742	1.18	742
2.30	720	F102_0089	MR160/050	56C	AW160/012	8.948	449	2.03	766	1.75	825	1.44	908
2.30	720	F102_0089	MR160/140	143/145TC	AW160/012	8.948	449	2.03	766	1.75	825	1.44	908
2.52	793	F202_0090	MR140/050	56C	AW140/010	9.006	579	2.09	793	1.67	793	1.25	793
4.56	1,435	F202_0090	MR160/050	56C	AW160/012	9.006	579	4.02	1,528	3.47	1,646	2.86	1,811
4.56	1,435	F202_0090	MR160/140	143/145TC	AW160/012	9.006	579	4.02	1,528	3.47	1,646	2.86	1,811
4.56	1,435	F202_0090	MR200/180	182/184/TC	AW200/014	9.006	579	4.02	1,528	3.47	1,646	2.86	1,811
7.60*	2,386	F302_0090	MR160/050	56C	AW160/012	8.986	803	6.70	2,541	5.78	2,737	4.77	3,012
7.60*	2,386	F302_0090	MR160/140	143/145TC	AW160/012	8.986	803	6.70	2,541	5.78	2,737	4.77	3,012
7.60*	2,386	F302_0090	MR200/180	182/184/TC	AW200/014	8.986	803	6.70	2,541	5.78	2,737	4.77	3,012
9.84	3,086	F402_0090	MR160/050	56C	AW160/012	8.980	991	8.15	3,086	6.52	3,086	4.89	3,086
9.84	3,086	F402_0090	MR160/140	143/145TC	AW160/012	8.980	991	8.15	3,086	6.52	3,086	4.89	3,086
9.84	3,091	F602_0090	MR160/050	56C	AW160/012	8.995	1,339	8.15	3,091	6.52	3,091	4.89	3,091
9.84	3,091	F602_0090	MR160/140	143/145TC	AW160/012	8.995	1,339	8.15	3,091	6.52	3,091	4.89	3,091
12.56*	3,941	F402_0090	MR200/180	182/184/TC	AW200/014	8.980	991	11.08	4,195	9.55	4,519	7.88	4,974
12.56*	3,941	F402_0090	MR250/210	213/215/TC	AW250/102	8.980	991	11.08	4,195	9.55	4,519	7.88	4,974
20.96*	6,589	F602_0090	MR200/180	182/184/TC	AW200/014	8.995	1,339	18.49	7,015	15.48	7,342	11.61	7,342
20.96*	6,589	F602_0090	MR250/180	182/184/TC	AW250/102	8.995	1,339	18.49	7,015	15.94	7,557	13.16	8,318
<b>160 RPM Output (Approximate) Continued Next Page</b>													
2.02	769	F102_0110	MR140/050	56C	AW140/010	10.920	472	1.78	819	1.52	876	1.14	876
2.02	769	F102_0110	MR160/050	56C	AW160/012	10.920	472	1.78	819	1.53	882	1.26	971
<b>130 RPM 105 RPM 80 RPM</b>													

### Part No. Explanation

F 6 0 2 A G 0560 AW160/012

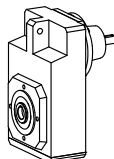
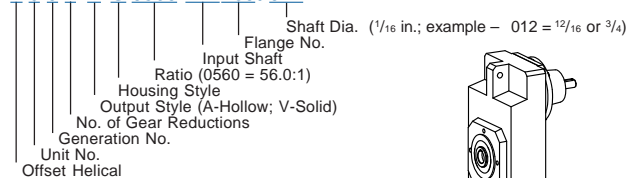

F 6 0 2 A G 0560 MR 160 /140

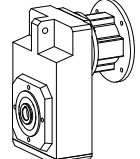
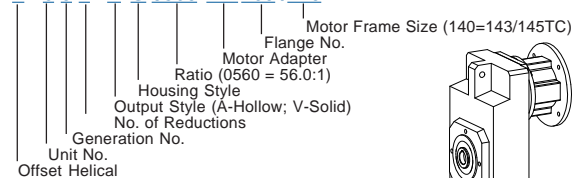

**Mounting position must be specified when ordering.**



# "F" Series – Offset Helical MGS Reducer – Selection Data



### Selection Procedure:

- Under the Input RPM heading, find **Approximate Output RPM** nearest the requirement.
- In the **Input HP** column locate the rating that is greater than or equal to the required HP.  
(If selection is based on Torque instead of HP, find an **Output Torque** that is equal to or greater than required.)
- When HP or Torque rating is located, read across that row to select the **Base Module**, **Input Option** and **Overhung Loads**.
- If exact **Output RPM** is required, divide the **Input RPM** by the **Exact Ratio**.

1750 RPM Input		Base Module <sup>1)</sup>	Input Options <sup>2)</sup>			Exact Ratio	Overhung Load Output Shaft <sup>3)</sup> lbs.	1450 RPM Input		1160 RPM Input		870 RPM Input	
Input HP	Output Torque in. lbs.		Motor Adapter	NEMA C-Frame Size <sup>4)</sup>	Input Shaft			Input HP	Output Torque in. lbs.	Input HP	Output Torque in. lbs.	Input HP	Output Torque in. lbs.

160 RPM Output (Approximate) Continued							130 RPM		105 RPM		80 RPM		
2.02	769	F102_0110	MR160/140	143/145TC	AW160/012	10.920	472	1.78	819	1.53	882	1.26	971
2.44	921	F202_0110	MR140/050	56C	AW140/010	10.803	606	2.02	921	1.62	921	1.21	921
4.04	1,525	F202_0110	MR160/050	56C	AW160/012	10.803	606	3.56	1,623	3.07	1,749	2.53	1,925
4.04	1,525	F202_0110	MR160/140	143/145TC	AW160/012	10.803	606	3.56	1,623	3.07	1,749	2.53	1,925
4.04	1,525	F202_0110	MR200/180	182/184/TC	AW200/014	10.803	606	3.56	1,623	3.07	1,749	2.53	1,925
6.73	2,536	F302_0110	MR160/050	56C	AW160/012	10.785	841	5.94	2,700	5.12	2,909	4.22	3,201
6.73	2,536	F302_0110	MR160/140	143/145TC	AW160/012	10.785	841	5.94	2,700	5.12	2,909	4.22	3,201
6.73	2,536	F302_0110	MR200/180	182/184/TC	AW200/014	10.785	841	5.94	2,700	5.12	2,909	4.22	3,201
9.84	3,718	F602_0110	MR160/050	56C	AW160/012	10.818	1,402	8.15	3,718	6.52	3,718	4.89	3,718
9.84	3,718	F602_0110	MR160/140	143/145TC	AW160/012	10.818	1,402	8.15	3,718	6.52	3,718	4.89	3,718
9.84	3,720	F402_0110	MR160/050	56C	AW160/012	10.825	1,038	8.15	3,720	6.52	3,720	4.89	3,720
9.84	3,720	F402_0110	MR160/140	143/145TC	AW160/012	10.825	1,038	8.15	3,720	6.52	3,720	4.89	3,720
11.09	4,194	F402_0110	MR200/180	182/184/TC	AW200/014	10.825	1,038	9.78	4,465	8.43	4,810	6.96	5,294
11.09	4,194	F402_0110	MR250/210	213/215/TC	AW250/102	10.825	1,038	9.78	4,465	8.43	4,810	6.96	5,294
18.54*	7,007	F602_0110	MR200/180	182/184/TC	AW200/014	10.818	1,402	16.35	7,460	14.09	8,037	11.61	8,830
18.54*	7,007	F602_0110	MR250/180	182/184/TC	AW250/102	10.818	1,402	16.35	7,460	14.09	8,037	11.63	8,845

130 RPM Output (Approximate)							105 RPM		85 RPM		65 RPM		
1.74	827	F102_0135	MR140/050	56C	AW140/010	13.588	499	1.54	881	1.32	949	1.09	1,044
1.74	827	F102_0135	MR160/050	56C	AW160/012	13.588	499	1.54	881	1.32	949	1.09	1,044
1.74	827	F102_0135	MR160/140	143/145TC	AW160/012	13.588	499	1.54	881	1.32	949	1.09	1,044
2.35	1,117	F202_0135	MR140/050	56C	AW140/010	13.625	642	1.94	1,117	1.56	1,117	1.17	1,117
2.42	1,133	F302_0135	MR140/050	56C	AW140/010	13.384	887	2.01	1,133	1.61	1,133	1.20	1,133
3.46	1,647	F202_0135	MR160/050	56C	AW160/012	13.625	642	3.05	1,754	2.63	1,889	2.17	2,079
3.46	1,647	F202_0135	MR160/140	143/145TC	AW160/012	13.625	642	3.05	1,754	2.63	1,889	2.17	2,079
3.46	1,647	F202_0135	MR200/180	182/184/TC	AW200/014	13.625	642	3.05	1,754	2.63	1,889	2.17	2,079
5.83	2,725	F302_0135	MR160/050	56C	AW160/012	13.384	887	5.14	2,902	4.43	3,126	3.66	3,440
5.83	2,725	F302_0135	MR160/140	143/145TC	AW160/012	13.384	887	5.14	2,902	4.43	3,126	3.66	3,440
5.83	2,725	F302_0135	MR200/180	182/184/TC	AW200/014	13.384	887	5.14	2,902	4.43	3,126	3.66	3,440
8.89	4,216	F402_0135	MR160/050	56C	AW160/012	13.569	1,098	7.84	4,489	6.52	4,664	4.89	4,664
8.89	4,216	F402_0135	MR160/140	143/145TC	AW160/012	13.569	1,098	7.84	4,489	6.52	4,664	4.89	4,664
9.54	4,522	F402_0135	MR200/180	182/184/TC	AW200/014	13.569	1,098	8.41	4,814	7.25	5,186	5.99	5,708
9.54	4,522	F402_0135	MR250/180	182/184/TC	AW250/102	13.569	1,098	8.41	4,814	7.25	5,186	5.99	5,708
9.84	4,677	F602_0135	MR160/050	56C	AW160/012	13.609	1,485	8.15	4,677	6.52	4,677	4.89	4,677
9.84	4,677	F602_0135	MR160/140	143/145TC	AW160/012	13.609	1,485	8.15	4,677	6.52	4,677	4.89	4,677
15.91*	7,564	F602_0135	MR200/180	182/184/TC	AW200/014	13.609	1,485	14.03	8,054	12.09	8,676	9.98	9,549
15.91*	7,564	F602_0135	MR250/180	182/184/TC	AW250/102	13.609	1,485	14.03	8,054	12.09	8,676	9.98	9,549

\* For thermal HP capacity, see rating below.

Base Module	F1	F2	F3	F4	F6
Thermal Capacity	2.95	5.36	7.38	12.34	14.75

NEMA Frame Size  
TEFC 1750 RPM

C-Frame	Motor HP
56C	1/3 - 1/2
143/145TC	1, 1 1/2, 2
182/184TC	3, 5
213/215TC	7 1/2, 10

### Housing Styles

F – Round Flange

G – Tapped Holes

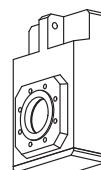
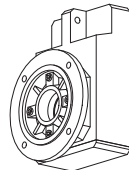

Some Housing Styles are available as Hollow (A) or Solid (V) Output.



# "F" Series – Offset Helical MGS Reducer – Selection Data



- NOTE:**
- 1) Complete Base Module Part Number by adding Output and Housing Style. Example: F302AG0560.
  - 2) Select Input Option and add to completed Part Number. See example below.
  - 3) Overhung Load is measured at the center of the shaft extension. Hollow output units are not intended to support overhung loads. If a load rating is required, use 50% of the published overhung load.
  - 4) Other frame sizes may also be available. See dimension pages.

1750 RPM Input		Base Module <sup>1)</sup>	Input Options <sup>2)</sup>			Exact Ratio	Overhung Load Output Shaft <sup>3)</sup> lbs.	1450 RPM Input		1160 RPM Input		870 RPM Input	
Input HP	Output Torque in. lbs.		Motor Adapter	NEMA C-Frame Size <sup>4)</sup>	Input Shaft			Input HP	Output Torque in. lbs.	Input HP	Output Torque in. lbs.	Input HP	Output Torque in. lbs.
<b>95 RPM Output (Approximate)</b>													
1.42	916	F102_0185	MR140/050	56C	AW140/010	18.457	539	1.25	975	1.08	1,050	0.82	1,063
1.42	916	F102_0185	MR160/050	56C	AW160/012	18.457	539	1.25	975	1.08	1,050	0.82	1,063
1.42	916	F102_0185	MR160/140	143/145TC	AW160/012	18.457	539	1.25	975	1.08	1,050	0.82	1,063
2.61	1,702	F202_0185	MR140/050	56C	AW140/010	18.651	694	2.16	1,702	1.73	1,702	1.30	1,702
2.81	1,829	F202_0185	MR160/050	56C	AW160/012	18.651	694	2.48	1,947	2.13	2,098	1.62	2,126
2.81	1,829	F202_0185	MR160/140	143/145TC	AW160/012	18.651	694	2.48	1,947	2.13	2,098	1.62	2,126
4.65	3,051	F302_0190	MR160/050	56C	AW160/012	18.774	966	4.10	3,248	3.54	3,499	2.69	3,543
4.65	3,051	F302_0190	MR160/140	143/145TC	AW160/012	18.774	966	4.10	3,248	3.54	3,499	2.69	3,543
4.65	3,051	F302_0190	MR200/180	182/184/TC	AW200/014	18.774	966	4.10	3,248	3.54	3,499	2.69	3,543
7.72	5,025	F402_0185	MR160/050	56C	AW160/012	18.620	1,189	6.81	5,350	5.87	5,763	4.74	6,201
7.72	5,025	F402_0185	MR160/140	143/145TC	AW160/012	18.620	1,189	6.81	5,350	5.87	5,763	4.74	6,201
7.72	5,025	F402_0185	MR200/180	182/184/TC	AW200/014	18.620	1,189	6.81	5,350	5.87	5,763	4.74	6,201
7.72	5,025	F402_0185	MR250/180	182/184/TC	AW250/102	18.620	1,189	6.81	5,350	5.87	5,763	4.74	6,201
12.95	8,383	F602_0185	MR200/180	182/184/TC	AW200/014	18.522	1,604	11.43	8,925	9.85	9,614	7.48	9,744
12.95	8,383	F602_0185	MR250/210	213/215/TC	AW250/102	18.522	1,604	11.43	8,925	9.85	9,614	7.48	9,744
<b>75 RPM Output (Approximate)</b>													
1.22	987	F102_0230	MR140/050	56C	AW140/010	23.080	569	1.08	1,051	0.87	1,063	0.66	1,063
1.22	987	F102_0230	MR160/050	56C	AW160/012	23.080	569	1.08	1,051	0.87	1,063	0.66	1,063
1.22	987	F102_0230	MR160/140	143/145TC	AW160/012	23.080	569	1.08	1,051	0.87	1,063	0.66	1,063
2.41	1,974	F202_0230	MR140/050	56C	AW140/010	23.434	735	2.09	2,064	1.67	2,064	1.25	2,064
2.41	1,974	F202_0230	MR160/050	56C	AW160/012	23.434	735	2.13	2,101	1.72	2,126	1.29	2,126
2.41	1,974	F202_0230	MR160/140	143/145TC	AW160/012	23.434	735	2.13	2,101	1.72	2,126	1.29	2,126
4.00	3,289	F302_0240	MR160/050	56C	AW160/012	23.520	1,022	3.53	3,501	2.86	3,543	2.14	3,543
4.00	3,289	F302_0240	MR160/140	143/145TC	AW160/012	23.520	1,022	3.53	3,501	2.86	3,543	2.14	3,543
4.00	3,289	F302_0240	MR200/180	182/184/TC	AW200/014	23.520	1,022	3.53	3,501	2.86	3,543	2.14	3,543
6.67	5,408	F402_0230	MR160/050	56C	AW160/012	23.214	1,256	5.88	5,758	5.07	6,201	3.80	6,201
6.67	5,408	F402_0230	MR160/140	143/145TC	AW160/012	23.214	1,256	5.88	5,758	5.07	6,201	3.80	6,201
6.67	5,408	F402_0230	MR200/180	182/184/TC	AW200/014	23.214	1,256	5.88	5,758	5.07	6,201	3.80	6,201
6.67	5,408	F402_0230	MR250/180	182/184/TC	AW250/102	23.214	1,256	5.88	5,758	5.07	6,201	3.80	6,201
9.84	7,998	F602_0230	MR160/050	56C	AW160/012	23.272	1,698	8.15	7,998	6.52	7,998	4.89	7,998
9.84	7,998	F602_0230	MR160/140	143/145TC	AW160/012	23.272	1,698	8.15	7,998	6.52	7,998	4.89	7,998
11.12	9,046	F602_0230	MR200/180	182/184/TC	AW200/014	23.272	1,698	9.81	9,631	7.94	9,744	5.96	9,744
11.12	9,046	F602_0230	MR250/180	182/184/TC	AW250/102	23.272	1,698	9.81	9,631	7.94	9,744	5.96	9,744
<b>60 RPM Output (Approximate) Continued Next Page</b>													
1.07	1,055	F102_0280	MR140/050	56C	AW140/010	28.167	599	0.89	1,063	0.72	1,063	0.54	1,063
1.07	1,055	F102_0280	MR160/050	56C	AW160/012	28.167	599	0.89	1,063	0.72	1,063	0.54	1,063
1.07	1,055	F102_0280	MR160/140	143/145TC	AW160/012	28.167	599	0.89	1,063	0.72	1,063	0.54	1,063
2.13	2,097	F202_0280	MR140/050	56C	AW140/010	28.112	769	1.79	2,126	1.43	2,126	1.08	2,126

### Part No. Explanation

F 6 0 2 A G 0560 AW160 / 012

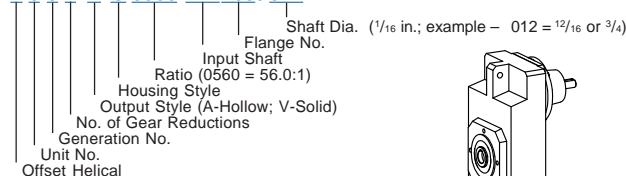

F 6 0 2 A G 0560 MR 160 / 140

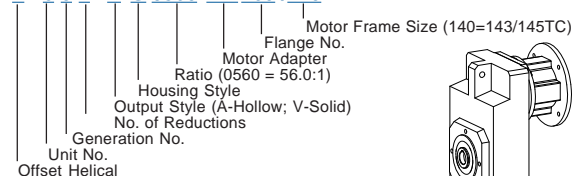

**Mounting position must be specified when ordering.**





# "F" Series – Offset Helical MGS Reducer – Selection Data



### Selection Procedure:

- Under the Input RPM heading, find **Approximate Output RPM** nearest the requirement.
- In the **Input HP** column locate the rating that is greater than or equal to the required HP.  
(If selection is based on Torque instead of HP, find an **Output Torque** that is equal to or greater than required.)
- When HP or Torque rating is located, read across that row to select the **Base Module**, **Input Option** and **Overhung Loads**.
- If exact **Output RPM** is required, divide the **Input RPM** by the **Exact Ratio**.

1750 RPM Input		Base Module <sup>1)</sup>	Input Options <sup>2)</sup>			Exact Ratio	Overhung Load Output Shaft <sup>3)</sup> lbs.	1450 RPM Input		1160 RPM Input		870 RPM Input	
Input HP	Output Torque in. lbs.		Motor Adapter	NEMA C-Frame Size <sup>4)</sup>	Input Shaft			Input HP	Output Torque in. lbs.	Input HP	Output Torque in. lbs.	Input HP	Output Torque in. lbs.
<b>60 RPM Output (Approximate) Continued</b>													
								<b>50 RPM</b>		<b>40 RPM</b>		<b>30 RPM</b>	
2.13	2,097	F202_0280	MR160/050	56C	AW160/012	28.112	769	1.79	2,126	1.43	2,126	1.08	2,126
2.13	2,097	F202_0280	MR160/140	143/145TC	AW160/012	28.112	769	1.79	2,126	1.43	2,126	1.08	2,126
3.54	3,495	F302_0280	MR160/050	56C	AW160/012	28.230	1,069	2.98	3,543	2.38	3,543	1.79	3,543
3.54	3,495	F302_0280	MR160/140	143/145TC	AW160/012	28.230	1,069	2.98	3,543	2.38	3,543	1.79	3,543
3.54	3,495	F302_0280	MR200/180	182/184/TC	AW200/014	28.230	1,069	2.98	3,543	2.38	3,543	1.79	3,543
5.89	5,756	F402_0280	MR160/050	56C	AW160/012	27.986	1,316	5.19	6,128	4.20	6,201	3.15	6,201
5.89	5,756	F402_0280	MR160/140	143/145TC	AW160/012	27.986	1,316	5.19	6,128	4.20	6,201	3.15	6,201
5.89	5,756	F402_0280	MR200/180	182/184/TC	AW200/014	27.986	1,316	5.19	6,128	4.20	6,201	3.15	6,201
5.89	5,756	F402_0280	MR250/180	182/184/TC	AW250/102	27.986	1,316	5.19	6,128	4.20	6,201	3.15	6,201
9.84	9,619	F602_0280	MR160/050	56C	AW160/012	27.986	1,779	8.15	9,619	6.52	9,619	4.89	9,619
9.84	9,619	F602_0280	MR160/140	143/145TC	AW160/012	27.986	1,779	8.15	9,619	6.52	9,619	4.89	9,619
9.84	9,619	F602_0280	MR200/180	182/184/TC	AW200/014	27.986	1,779	8.26	9,744	6.60	9,744	4.95	9,744
9.84	9,619	F602_0280	MR250/180	182/184/TC	AW250/102	27.986	1,779	8.26	9,744	6.60	9,744	4.95	9,744
<b>50 RPM Output (Approximate)</b>													
								<b>40 RPM</b>		<b>30 RPM</b>		<b>25 RPM</b>	
0.87	1,063	F102_0350	MR140/050	56C	AW140/010	35.049	632	0.72	1,063	0.58	1,063	0.43	1,063
0.87	1,063	F102_0350	MR160/050	56C	AW160/012	35.049	632	0.72	1,063	0.58	1,063	0.43	1,063
1.72	2,126	F202_0350	MR140/050	56C	AW140/010	35.455	815	1.42	2,126	1.14	2,126	0.85	2,126
1.72	2,126	F202_0350	MR160/140	143/145TC	AW160/012	35.455	815	1.42	2,126	1.14	2,126	0.85	2,126
2.42	2,967	F302_0350	MR140/050	56C	AW140/010	35.034	1,129	2.01	2,967	1.61	2,967	1.20	2,967
2.89	3,543	F302_0350	MR160/050	56C	AW160/012	35.034	1,129	2.40	3,543	1.92	3,543	1.44	3,543
2.89	3,543	F302_0350	MR160/140	143/145TC	AW160/012	35.034	1,129	2.40	3,543	1.92	3,543	1.44	3,543
5.06	6,201	F402_0350	MR160/050	56C	AW160/012	35.079	1,393	4.19	6,201	3.35	6,201	2.51	6,201
5.06	6,201	F402_0350	MR160/140	143/145TC	AW160/012	35.079	1,393	4.19	6,201	3.35	6,201	2.51	6,201
5.06	6,201	F402_0350	MR200/180	182/184/TC	AW200/014	35.079	1,393	4.19	6,201	3.35	6,201	2.51	6,201
5.06	6,201	F402_0350	MR250/180	182/184/TC	AW250/102	35.079	1,393	4.19	6,201	3.35	6,201	2.51	6,201
7.92	9,744	F602_0350	MR160/050	56C	AW160/012	35.208	1,884	6.56	9,744	5.25	9,744	3.94	9,744
7.92	9,744	F602_0350	MR160/140	143/145TC	AW160/012	35.208	1,884	6.56	9,744	5.25	9,744	3.94	9,744
7.92	9,744	F602_0350	MR200/180	182/184/TC	AW200/014	35.208	1,884	6.56	9,744	5.25	9,744	3.94	9,744
7.92	9,744	F602_0350	MR250/180	182/184/TC	AW250/102	35.208	1,884	6.56	9,744	5.25	9,744	3.94	9,744
<b>35 RPM Output (Approximate) Continued Next Page</b>													
								<b>30 RPM</b>		<b>25 RPM</b>		<b>18.5 RPM</b>	
0.66	1,063	F102_0460	MR140/050	56C	AW140/010	46.429	678	0.54	1,063	0.43	1,063	0.33	1,063
0.66	1,063	F102_0460	MR160/050	56C	AW160/012	46.429	678	0.54	1,063	0.43	1,063	0.33	1,063
1.29	2,126	F202_0470	MR140/050	56C	AW140/010	47.045	875	1.07	2,126	0.86	2,126	0.64	2,126
1.29	2,126	F202_0470	MR160/050	56C	AW160/012	47.045	875	1.07	2,126	0.86	2,126	0.64	2,126
1.29	2,126	F202_0470	MR160/140	143/145TC	AW160/012	47.045	875	1.07	2,126	0.86	2,126	0.64	2,126
2.15	3,543	F302_0470	MR140/050	56C	AW140/010	47.185	1,216	1.78	3,543	1.42	3,543	1.07	3,543
2.15	3,543	F302_0470	MR160/050	56C	AW160/012	47.185	1,216	1.78	3,543	1.42	3,543	1.07	3,543
2.15	3,543	F302_0470	MR160/140	143/145TC	AW160/012	47.185	1,216	1.78	3,543	1.42	3,543	1.07	3,543

\* For thermal HP capacity, see rating below.

Base Module	F1	F2	F3	F4	F6
Thermal Capacity	2.95	5.36	7.38	12.34	14.75

NEMA Frame Size  
TEFC 1750 RPM

C-Frame	Motor HP
56C	1/3 - 1/2
143/145TC	1, 1 1/2, 2
182/184TC	3, 5
213/215TC	7 1/2, 10

### Housing Styles

F – Round Flange

G – Tapped Holes

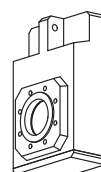
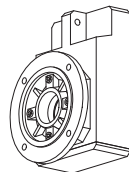

Some Housing Styles are available as Hollow (A) or Solid (V) Output.





# "F" Series – Offset Helical MGS Reducer – Selection Data



- NOTE:**
- 1) Complete Base Module Part Number by adding Output and Housing Style. Example: F302AG0560.
  - 2) Select Input Option and add to completed Part Number. See example below.
  - 3) Overhung Load is measured at the center of the shaft extension. Hollow output units are not intended to support overhung loads. If a load rating is required, use 50% of the published overhung load.
  - 4) Other frame sizes may also be available. See dimension pages.

1750 RPM Input		Base Module <sup>1)</sup>	Input Options <sup>2)</sup>			Exact Ratio	Overhung Load Output Shaft <sup>3)</sup> lbs.	1450 RPM Input		1160 RPM Input		870 RPM Input	
Input HP	Output Torque in. lbs.		Motor Adapter	NEMA C-Frame Size <sup>4)</sup>	Input Shaft			Input HP	Output Torque in. lbs.	Input HP	Output Torque in. lbs.	Input HP	Output Torque in. lbs.
<b>35 RPM Output (Approximate) Continued</b>													
3.78	6,201	F402_0470	MR160/050	56C	AW160/012	46.944	1,498	3.13	6,201	2.51	6,201	1.88	6,201
3.78	6,201	F402_0470	MR160/140	143/145TC	AW160/012	46.944	1,498	3.13	6,201	2.51	6,201	1.88	6,201
3.78	6,201	F402_0470	MR200/180	182/184/TC	AW200/014	46.944	1,498	3.13	6,201	2.51	6,201	1.88	6,201
3.78	6,201	F402_0470	MR250/180	182/184/TC	AW250/102	46.944	1,498	3.13	6,201	2.51	6,201	1.88	6,201
5.97	9,744	F602_0470	MR160/050	56C	AW160/012	46.719	2,022	4.95	9,744	3.96	9,744	2.97	9,744
5.97	9,744	F602_0470	MR160/140	143/145TC	AW160/012	46.719	2,022	4.95	9,744	3.96	9,744	2.97	9,744
5.97	9,744	F602_0470	MR200/180	182/184/TC	AW200/014	46.719	2,022	4.95	9,744	3.96	9,744	2.97	9,744
5.97	9,744	F602_0470	MR250/180	182/184/TC	AW250/102	46.719	2,022	4.95	9,744	3.96	9,744	2.97	9,744
<b>30 RPM Output (Approximate)</b>													
0.54	1,063	F102_0560	MR140/050	56C	AW140/010	55.972	711	0.45	1,063	0.36	1,063	0.27	1,063
0.54	1,063	F102_0560	MR160/050	56C	AW160/012	55.972	711	0.45	1,063	0.36	1,063	0.27	1,063
1.07	2,126	F202_0570	MR140/050	56C	AW140/010	56.727	917	0.89	2,126	0.71	2,126	0.53	2,126
1.07	2,126	F202_0570	MR160/050	56C	AW160/012	56.727	917	0.89	2,126	0.71	2,126	0.53	2,126
1.07	2,126	F202_0570	MR160/140	143/145TC	AW160/012	56.727	917	0.89	2,126	0.71	2,126	0.53	2,126
1.80	3,543	F302_0560	MR140/050	56C	AW140/010	56.486	1,272	1.49	3,543	1.19	3,543	0.89	3,543
1.80	3,543	F302_0560	MR160/050	56C	AW160/012	56.486	1,272	1.49	3,543	1.19	3,543	0.89	3,543
1.80	3,543	F302_0560	MR160/140	143/145TC	AW160/012	56.486	1,272	1.49	3,543	1.19	3,543	0.89	3,543
3.17	6,201	F402_0560	MR160/050	56C	AW160/012	55.972	1,565	2.63	6,201	2.10	6,201	1.58	6,201
3.17	6,201	F402_0560	MR160/140	143/145TC	AW160/012	55.972	1,565	2.63	6,201	2.10	6,201	1.58	6,201
3.17	6,201	F402_0560	MR200/180	182/184/TC	AW200/014	55.972	1,565	2.63	6,201	2.10	6,201	1.58	6,201
3.17	6,201	F402_0560	MR250/210	213/215/TC	AW250/102	55.972	1,565	2.63	6,201	2.10	6,201	1.58	6,201
5.01	9,744	F602_0560	MR160/050	56C	AW160/012	55.714	2,113	4.15	9,744	3.32	9,744	2.49	9,744
5.01	9,744	F602_0560	MR160/140	143/145TC	AW160/012	55.714	2,113	4.15	9,744	3.32	9,744	2.49	9,744
5.01	9,744	F602_0560	MR200/180	182/184/TC	AW200/014	55.714	2,113	4.15	9,744	3.32	9,744	2.49	9,744
5.01	9,744	F602_0560	MR250/180	182/184/TC	AW250/102	55.714	2,113	4.15	9,744	3.32	9,744	2.49	9,744
<b>25 RPM Output (Approximate)</b>													
0.43	1,063	F102_0700	MR140/050	56C	AW140/010	70.056	752	0.36	1,063	0.29	1,063	0.22	1,063
0.43	1,063	F102_0700	MR160/050	56C	AW160/012	70.056	752	0.36	1,063	0.29	1,063	0.22	1,063
0.87	2,126	F202_0700	MR140/050	56C	AW140/010	70.130	967	0.72	2,126	0.58	2,126	0.43	2,126
0.87	2,126	F202_0700	MR160/050	56C	AW160/012	70.130	967	0.72	2,126	0.58	2,126	0.43	2,126
1.44	3,543	F302_0700	MR140/050	56C	AW140/010	70.359	1,344	1.19	3,543	0.96	3,543	0.72	3,543
1.44	3,543	F302_0700	MR160/050	56C	AW160/012	70.359	1,344	1.19	3,543	0.96	3,543	0.72	3,543
1.44	3,543	F302_0700	MR160/140	143/145TC	AW160/012	70.359	1,344	1.19	3,543	0.96	3,543	0.72	3,543
2.53	6,201	F402_0700	MR160/050	56C	AW160/012	70.056	1,655	2.10	6,201	1.68	6,201	1.26	6,201
2.53	6,201	F402_0700	MR160/140	143/145TC	AW160/012	70.056	1,655	2.10	6,201	1.68	6,201	1.26	6,201
4.00	9,744	F602_0700	MR160/050	56C	AW160/012	69.643	2,234	3.32	9,744	2.65	9,744	1.99	9,744
4.00	9,744	F602_0700	MR160/140	143/145TC	AW160/012	69.643	2,234	3.32	9,744	2.65	9,744	1.99	9,744
4.00	9,744	F602_0700	MR200/180	182/184/TC	AW200/014	69.643	2,234	3.32	9,744	2.65	9,744	1.99	9,744
4.00	9,744	F602_0700	MR250/210	213/215/TC	AW250/102	69.643	2,234	3.32	9,744	2.65	9,744	1.99	9,744

### Part No. Explanation

F 6 0 2 A G 0560 AW160/012

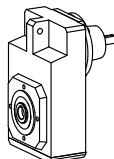
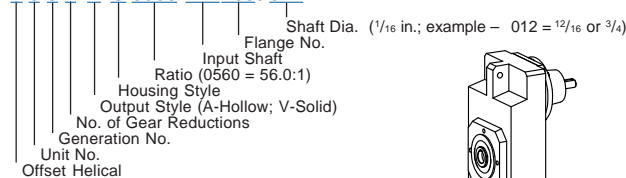

F 6 0 2 A G 0560 MR 160 /140

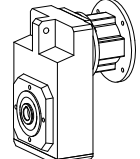
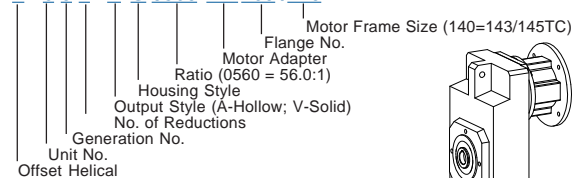

**Mounting position must be specified when ordering.**





# "F" Series – Offset Helical MGS Reducer – Selection Data



### Selection Procedure:

- Under the Input RPM heading, find **Approximate Output RPM** nearest the requirement.
- In the **Input HP** column locate the rating that is greater than or equal to the required HP.  
(If selection is based on Torque instead of HP, find an **Output Torque** that is equal to or greater than required.)
- When HP or Torque rating is located, read across that row to select the **Base Module**, **Input Option** and **Overhung Loads**.
- If exact **Output RPM** is required, divide the **Input RPM** by the **Exact Ratio**.

1750 RPM Input		Base Module <sup>1)</sup>	Input Options <sup>2)</sup>			Exact Ratio	Overhung Load Output Shaft <sup>3)</sup> lbs.	1450 RPM Input		1160 RPM Input		870 RPM Input	
Input HP	Output Torque in. lbs.		Motor Adapter	NEMA C-Frame Size <sup>4)</sup>	Input Shaft			Input HP	Output Torque in. lbs.	Input HP	Output Torque in. lbs.	Input HP	Output Torque in. lbs.
<b>18.5 RPM Output (Approximate)</b>													
								<b>15.5 RPM</b>	<b>12.5 RPM</b>	<b>9 RPM</b>			
0.32	1,063	F102_0940	MR140/050	56C	AW140/010	93.631	808	0.27	1,063	0.22	1,063	0.16	1,063
0.65	2,126	F202_0940	MR140/050	56C	AW140/010	93.818	1,040	0.54	2,126	0.43	2,126	0.32	2,126
0.65	2,126	F202_0940	MR160/050	56C	AW160/012	93.818	1,040	0.54	2,126	0.43	2,126	0.32	2,126
1.08	3,543	F302_0940	MR140/050	56C	AW140/010	93.644	1,443	0.90	3,543	0.72	3,543	0.54	3,543
1.08	3,543	F302_0940	MR160/050	56C	AW160/012	93.644	1,443	0.90	3,543	0.72	3,543	0.54	3,543
1.08	3,543	F302_0940	MR160/140	143/145TC	AW160/012	93.644	1,443	0.90	3,543	0.72	3,543	0.54	3,543
1.90	6,201	F402_0930	MR160/050	56C	AW160/012	93.333	1,779	1.58	6,201	1.26	6,201	0.95	6,201
1.90	6,201	F402_0930	MR160/140	143/145TC	AW160/012	93.333	1,779	1.58	6,201	1.26	6,201	0.95	6,201
2.99	9,744	F602_0930	MR160/050	56C	AW160/012	93.333	2,403	2.48	9,744	1.98	9,744	1.49	9,744
2.99	9,744	F602_0930	MR160/140	143/145TC	AW160/012	93.333	2,403	2.48	9,744	1.98	9,744	1.49	9,744
<b>15.5 RPM Output (Approximate)</b>													
								<b>12.5 RPM</b>	<b>10.5 RPM</b>	<b>8 RPM</b>			
0.27	1,063	F102_1120	MR140/050	56C	AW140/010	111.944	845	0.23	1,063	0.18	1,063	0.14	1,063
0.54	2,126	F202_1130	MR140/050	56C	AW140/010	112.727	1,088	0.45	2,126	0.36	2,126	0.27	2,126
0.90	3,543	F302_1130	MR140/050	56C	AW140/010	112.848	1,512	0.74	3,543	0.60	3,543	0.45	3,543
0.90	3,543	F302_1130	MR160/050	56C	AW160/012	112.848	1,512	0.74	3,543	0.60	3,543	0.45	3,543
1.58	6,201	F402_1120	MR160/050	56C	AW160/012	112.273	1,863	1.31	6,201	1.05	6,201	0.79	6,201
1.58	6,201	F402_1120	MR160/140	143/145TC	AW160/012	112.273	1,863	1.31	6,201	1.05	6,201	0.79	6,201
2.49	9,744	F602_1120	MR160/050	56C	AW160/012	112.202	2,517	2.06	9,744	1.65	9,744	1.24	9,744
2.49	9,744	F602_1120	MR160/140	143/145TC	AW160/012	112.202	2,517	2.06	9,744	1.65	9,744	1.24	9,744
<b>12.5 RPM Output (Approximate)</b>													
								<b>10 RPM</b>	<b>8 RPM</b>	<b>6 RPM</b>			
0.22	1,063	F102_1400	MR140/050	56C	AW140/010	139.750	893	0.18	1,063	0.14	1,063	0.11	1,063
0.43	2,126	F202_1410	MR140/050	56C	AW140/010	140.909	1,151	0.36	2,126	0.29	2,126	0.21	2,126
0.72	3,543	F302_1410	MR140/050	56C	AW140/010	140.648	1,598	0.60	3,543	0.48	3,543	0.36	3,543
1.27	6,201	F402_1400	MR160/050	56C	AW160/012	139.750	1,967	1.05	6,201	0.84	6,201	0.63	6,201
1.27	6,201	F402_1400	MR160/140	143/145TC	AW160/012	139.750	1,967	1.05	6,201	0.84	6,201	0.63	6,201
2.00	9,744	F602_1400	MR160/050	56C	AW160/012	139.750	2,659	1.65	9,744	1.32	9,744	0.99	9,744
2.00	9,744	F602_1400	MR160/140	143/145TC	AW160/012	139.750	2,659	1.65	9,744	1.32	9,744	0.99	9,744
<b>9.5 RPM Output (Approximate)</b>													
								<b>8 RPM</b>	<b>6 RPM</b>	<b>5 RPM</b>			
0.34	2,126	F203_1840	MR140/050	56C	AW140/010	184.261	1,215	0.28	2,126	0.22	2,126	0.16	2,126
0.56	3,543	F303_1850	MR140/050	56C	AW140/010	184.809	1,688	0.46	3,543	0.36	3,543	0.27	3,543
0.56	3,543	F303_1820	MR160/050	56C	AW160/012	182.449	1,688	0.47	3,543	0.37	3,543	0.28	3,543
0.98	6,201	F403_1840	MR140/050	56C	AW140/010	183.866	2,081	0.81	6,201	0.64	6,201	0.48	6,201
0.99	6,201	F403_1820	MR160/050	56C	AW160/012	181.519	2,081	0.82	6,201	0.65	6,201	0.49	6,201
1.57	9,744	F603_1810	MR160/050	56C	AW160/012	180.646	2,813	1.30	9,744	1.02	9,744	0.77	9,744
1.57	9,744	F603_1810	MR160/140	143/145TC	AW160/012	180.646	2,813	1.30	9,744	1.02	9,744	0.77	9,744

\* For thermal HP capacity, see rating below.

Base Module	F1	F2	F3	F4	F6
Thermal Capacity	2.95	5.36	7.38	12.34	14.75

NEMA Frame Size  
TEFC 1750 RPM

C-Frame	Motor HP
56C	1/3 - 1/2
143/145TC	1, 1 1/2, 2
182/184TC	3, 5
213/215TC	7 1/2, 10

### Housing Styles

F – Round Flange

G – Tapped Holes

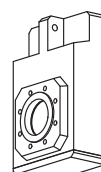
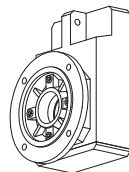

Some Housing Styles are available as Hollow (A) or Solid (V) Output.



# "F" Series – Offset Helical MGS Reducer – Selection Data



- NOTE:** 1) Complete Base Module Part Number by adding Output and Housing Style. Example: F302AG0560.  
 2) Select Input Option and add to completed Part Number. See example below.  
 3) Overhung Load is measured at the center of the shaft extension. Hollow output units are not intended to support overhung loads. If a load rating is required, use 50% of the published overhung load.  
 4) Other frame sizes may also be available. See dimension pages.

1750 RPM Input		Base Module 1)	Input Options 2)			Exact Ratio	Overhung Load Output Shaft <sup>3)</sup> lbs.	1450 RPM Input		1160 RPM Input		870 RPM Input	
Input HP	Output Torque in. lbs.		Motor Adapter	NEMA C-Frame Size 4)	Input Shaft			Input HP	Output Torque in. lbs.	Input HP	Output Torque in. lbs.	Input HP	Output Torque in. lbs.
<b>8 RPM Output (Approximate)</b>													
0.28	2,126	F203_2220	MR140/050	56C	AW140/010	222.182	1,215	0.23	2,126	0.18	2,126	0.14	2,126
0.47	3,543	F303_2210	MR140/050	56C	AW140/010	221.237	1,688	0.39	3,543	0.30	3,543	0.23	3,543
0.47	3,543	F303_2180	MR160/050	56C	AW160/012	218.413	1,688	0.39	3,543	0.31	3,543	0.23	3,543
0.82	6,201	F403_2190	MR140/050	56C	AW140/010	219.225	2,081	0.68	6,201	0.54	6,201	0.40	6,201
0.83	6,201	F403_2160	MR160/050	56C	AW160/012	216.426	2,081	0.69	6,201	0.54	6,201	0.41	6,201
1.31	9,744	F603_2150	MR160/050	56C	AW160/012	215.429	2,813	1.09	9,744	0.86	9,744	0.64	9,744
1.31	9,744	F603_2150	MR160/140	143/145TC	AW160/012	215.429	2,813	1.09	9,744	0.86	9,744	0.64	9,744
<b>6.5 RPM Output (Approximate)</b>													
0.22	2,126	F203_2750	MR140/050	56C	AW140/010	274.675	1,215	0.19	2,126	0.15	2,126	0.11	2,126
0.37	3,543	F303_2760	MR140/050	56C	AW140/010	275.573	1,688	0.31	3,543	0.24	3,543	0.18	3,543
0.38	3,543	F303_2720	MR160/050	56C	AW160/012	272.055	1,688	0.31	3,543	0.25	3,543	0.19	3,543
0.66	6,201	F403_2740	MR140/050	56C	AW140/010	274.384	2,081	0.54	6,201	0.43	6,201	0.32	6,201
0.67	6,201	F403_2710	MR160/050	56C	AW160/012	270.881	2,081	0.55	6,201	0.43	6,201	0.33	6,201
1.05	9,744	F603_2690	MR160/050	56C	AW160/012	269.286	2,813	0.87	9,744	0.69	9,744	0.51	9,744
1.05	9,744	F603_2690	MR160/140	143/145TC	AW160/012	269.286	2,813	0.87	9,744	0.69	9,744	0.51	9,744
<b>5 RPM Output (Approximate)</b>													
0.17	2,126	F203_3670	MR140/050	56C	AW140/010	367.455	1,215	0.14	2,126	0.11	2,126	0.08	2,126
0.28	3,543	F303_3670	MR140/050	56C	AW140/010	366.774	1,688	0.23	3,543	0.18	3,543	0.14	3,543
0.28	3,543	F303_3620	MR160/050	56C	AW160/012	362.092	1,688	0.24	3,543	0.19	3,543	0.14	3,543
0.49	6,201	F403_3660	MR140/050	56C	AW140/010	365.556	2,081	0.41	6,201	0.32	6,201	0.24	6,201
0.50	6,201	F403_3610	MR160/050	56C	AW160/012	360.889	2,081	0.41	6,201	0.33	6,201	0.24	6,201
0.78	9,744	F603_3610	MR160/050	56C	AW160/012	360.889	2,813	0.65	9,744	0.51	9,744	0.38	9,744
<b>4 RPM Output (Approximate)</b>													
0.14	2,126	F203_4420	MR140/050	56C	AW140/010	441.515	1,215	0.12	2,126	0.09	2,126	0.07	2,126
0.23	3,543	F303_4420	MR140/050	56C	AW140/010	441.990	1,688	0.19	3,543	0.15	3,543	0.11	3,543
0.41	6,201	F403_4400	MR140/050	56C	AW140/010	439.735	2,081	0.34	6,201	0.27	6,201	0.20	6,201
0.41	6,201	F403_4340	MR160/050	56C	AW160/012	434.121	2,081	0.34	6,201	0.27	6,201	0.20	6,201
0.65	9,744	F603_4340	MR160/050	56C	AW160/012	433.849	2,813	0.54	9,744	0.43	9,744	0.32	9,744
<b>3 RPM Output (Approximate)</b>													
0.11	2,126	F203_5520	MR140/050	56C	AW140/010	551.894	1,215	0.09	2,126	0.07	2,126	0.05	2,126
0.19	3,543	F303_5510	MR140/050	56C	AW140/010	550.872	1,688	0.15	3,543	0.12	3,543	0.09	3,543
0.33	6,201	F403_5470	MR140/050	56C	AW140/010	547.354	2,081	0.27	6,201	0.21	6,201	0.16	6,201
0.52	9,744	F603_5400	MR160/050	56C	AW160/012	540.367	2,813	0.43	9,744	0.34	9,744	0.26	9,744

**NOTE: For slower speeds than those listed, units can be combined. Contact STÖBER Drives Inc.**

### Part No. Explanation

F 6 0 2 A G 0560 AW160 /012

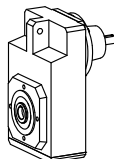
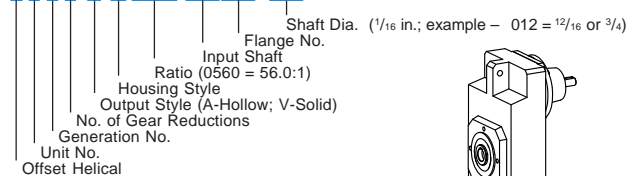

F 6 0 2 A G 0560 MR 160 /140

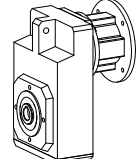
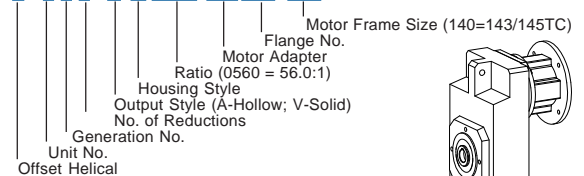

**Mounting position must be specified when ordering.**

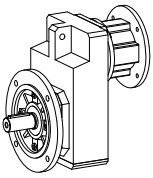

# "F" Series – MGS Reducer Round Flange – "F" Housing Shaft Output – Dimensional Data

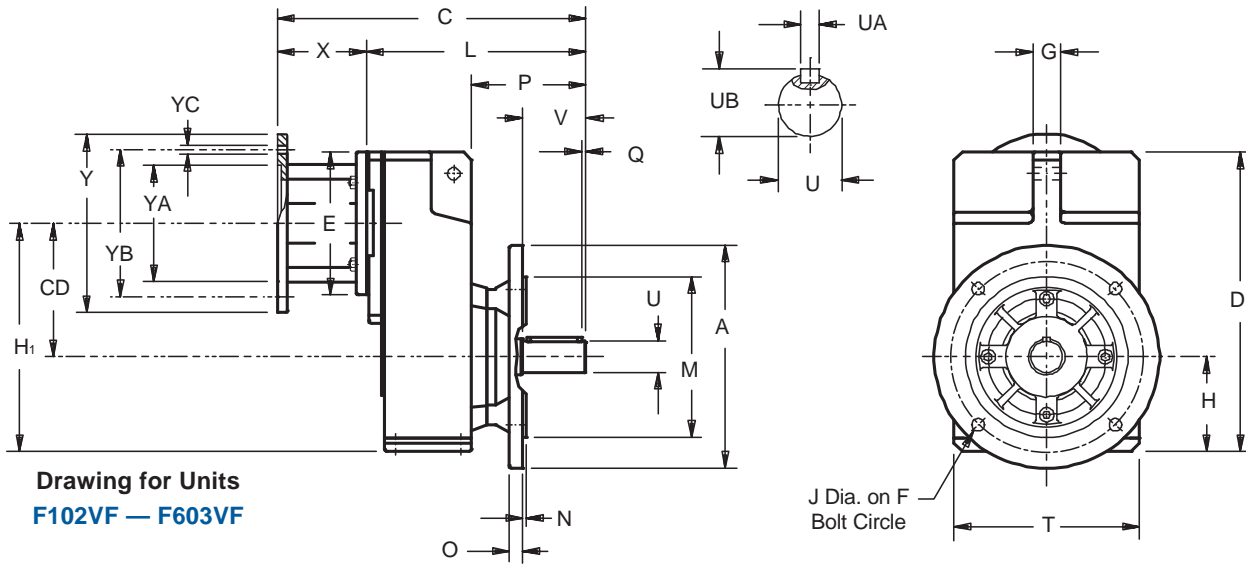

Drawing for Units  
F102VF – F603VF

Table No. 1 "F" Series – Round Flange Dimensions (Inches) – "F" Housing Style

Base Module	CD	A	D	F	G	H	H <sub>1</sub>	J	M	N	O	P	Q	T	V
<b>F102</b>	4.02	6.30	9.37	5.12	.79	2.91	6.93	.35	4.331	.14	.39	3.80	.16	5.71	1.97
<b>F202/F203</b>	5.16	7.87	11.77	6.50	.87	3.66	8.82	.43	5.118	.14	.55	4.53	.16	7.09	2.36
<b>F302/F303</b>	5.89	9.84	13.23	8.46	1.18	4.17	10.06	.55	7.087	.16	.59	5.10	.16	8.11	2.76
<b>F402/F403</b>	6.65 <sup>1)</sup>	9.84	14.57	8.46	1.18	4.57	11.22	.55	7.087	.16	.59	5.49	.16	9.06	3.15
<b>F602/F603</b>	7.72	11.81	17.64	10.43	1.38	5.39	13.11	.55	9.055	.16	.67	6.44	.20	10.43	3.94

<sup>1)</sup> C.D. is 5.19 for F403 with MR160/050 or MR160/140 input.

Table No. 2 "F" Series – "F" Housing Style

Motor Adapter	NEMA C-Flange	E	X	Y	YA	YB	YC	Wt. lbs.
<b>MR140/050</b>	56C	5.51	3.31	6.50	4.500	5.87	.41	9
<b>MR160/050</b>	56C	6.30	3.86	6.50	4.500	5.87	.41	16
<b>MR160/140</b>	143/145TC	6.30	3.86	6.50	4.500	5.87	.41	16
<b>MR200/180</b>	182/184TC	7.87	4.80	9.00	8.500	7.25	.55	23
<b>MR250/180</b>	182/184TC	9.84	5.31	9.00	8.500	7.25	.55	36
<b>MR250/210</b>	213/215TC	9.84	5.31	9.00	8.500	7.25	.55	36

Table No. 3 Metric output available on request

Base Module	Standard Shaft - inches			Optional Shaft - mm		
	U	UA	UB	U	UA	UB
<b>F102</b>	1.000	1/4 x 1/4 x 1 <sup>9</sup> / <sub>16</sub>	1.11	25 <sub>k6</sub>	A8x7x40	28
<b>F202/F203</b>	1.250	1/4 x 1/4 x 1 <sup>15</sup> / <sub>16</sub>	1.36	30 <sub>k6</sub>	A8x7x50	33
<b>F302/F303</b>	1.375	5/16 x 5/16 x 2 <sup>5</sup> / <sub>16</sub>	1.51	35 <sub>k6</sub>	A10x8X60	38
<b>F402/F403</b>	1.625	3/8 x 3/8 x 2 <sup>7</sup> / <sub>8</sub>	1.79	40 <sub>k6</sub>	A12x8X70	43
<b>F602/F603</b>	2.125	1/2 x 1/2 x 3 <sup>5</sup> / <sub>32</sub>	2.35	50 <sub>k6</sub>	A14x9X90	53.5

Table No. 4 Motor Adapter Dimensions (Inches)

Base Module	MR140/050	MR160/140 <sup>2)</sup>	MR200/180	MR250/210 <sup>3)</sup>	Approx. Wt. lbs.
	C	L	C	L	
<b>F102</b>	10.40	7.09	11.10	7.24	38
<b>F202</b>	11.70	8.39	12.40	8.54	51
<b>F203</b>	13.15	9.84	—	—	64
<b>F302</b>	12.76	9.45	13.47	9.61	67
<b>F303</b>	14.22	10.91	15.13	11.28	73
<b>F402</b>	—	—	14.45	10.59	84
<b>F403</b>	15.20	11.89	16.14	12.28	91
<b>F602</b>	—	—	16.46	12.60	165
<b>F603</b>	—	—	18.15	14.29	177

<sup>2)</sup> Also available as **MR160/050** for a NEMA 56C frame motor.

<sup>3)</sup> Also available as **MR250/180** for a NEMA 182/184TC frame motor.

All weights are approximate.

**Part No. Example**  
Round Flange with Motor Adapter  
**F302VF0620 MR160/140**





# "F" Series – MGS Reducer Tapped Holes – "G" Housing Hollow Output – Dimensional Data

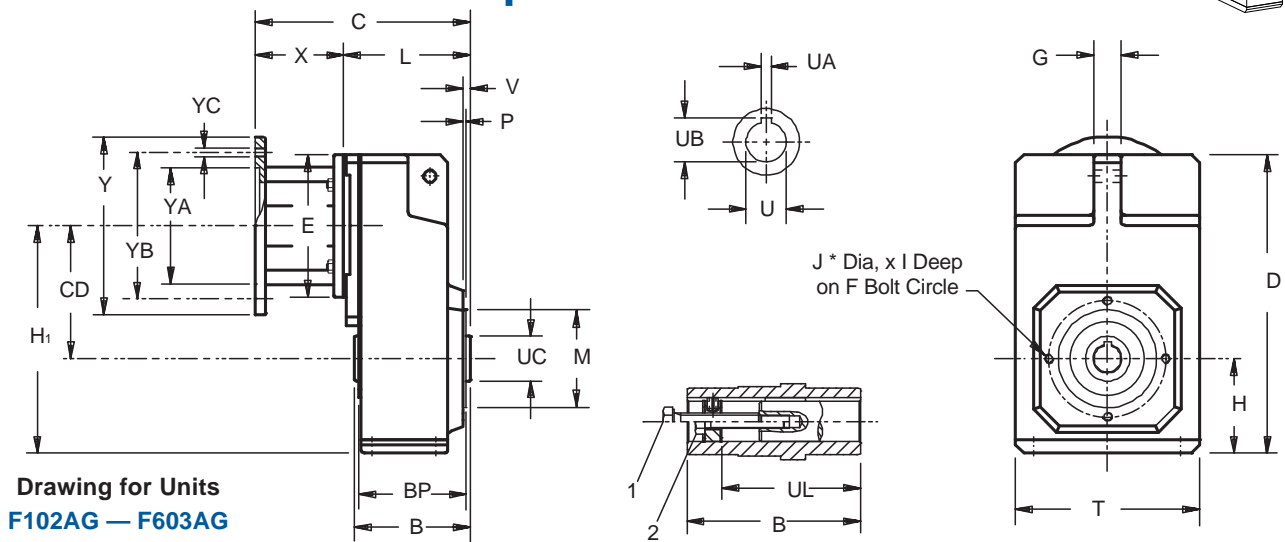
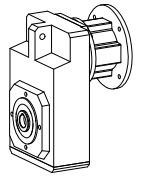

**Table No. 1 "F" Series – Tapped Holes Unit Dimensions (Inches) – "G" Housing Style**

Base Module	CD	B	C	D	D <sub>1</sub>	F	F <sub>1</sub>	G	H	H <sub>1</sub>	H <sub>2</sub>	I	J *	M	L <sub>1</sub>	O	P	T	V	BP	RB
<b>F102</b>	4.02	3.74	2.86	9.37	.43	3.35	5.91	.79	2.91	6.93	.55	.51	M8	2.756	.59	1.38	.10	5.71	.26	3.43	1.18
<b>F202/203</b>	5.16	4.53	3.55	11.77	.43	4.53	7.13	.87	3.66	8.82	.98	.51	M8	3.740	.59	1.57	.12	7.09	.31	4.13	1.18
<b>F302/303</b>	5.89	5.12	4.06	13.23	.55	5.12	8.07	1.18	4.17	10.06	.96	.63	M10	4.331	.79	1.77	.14	8.11	.33	4.72	1.57
<b>F402/403</b>	6.65 <sup>1)</sup>	5.71	4.53	14.57	.55	5.12	8.98	1.18	4.57	11.22	1.02	.63	M10	4.331	.79	1.77	.14	9.06	.33	5.31	1.57
<b>F602/603</b>	7.72	7.09	5.22	17.64	.57	6.50	10.63	1.38	5.39	13.11	1.02	.63	M10	5.118	1.18	2.77	.14	10.43	.41	6.54	2.36

\*F602 and F603 has 8 tapped holes instead of 4 as shown on drawing.  
<sup>1)</sup> C.D. is 5.19 for F403 with MR160/050 or MR160/140 input.

1. Removal Bolt —not supplied.  
 2. Mounting Bolt —must be smaller than removal bolt.

**Table No. 2 "F" Series — "G" Housing Style**

Motor Adapter	NEMA C-Flange	E	X	Y	YA	YB	YC	Wt. lbs.
<b>MR140/050</b>	56C	5.51	3.31	6.50	4.500	5.87	.41	9
<b>MR160/050</b>	56C	6.30	3.86	6.50	4.500	5.87	.41	16
<b>MR160/140</b>	143/145TC	6.30	3.86	6.50	4.500	5.87	.41	16
<b>MR200/180</b>	182/184TC	7.87	4.80	9.00	8.500	7.25	.55	23
<b>MR250/180</b>	182/184TC	9.84	5.31	9.00	8.500	7.25	.55	36
<b>MR250/210</b>	213/215TC	9.84	5.31	9.00	8.500	7.25	.55	36

**Part No. Example**

Tapped Holes Housing with Motor Adapter  
**F302AG0620 MR160/140**

**Rubber Buffer for Torque Arm Mounting**

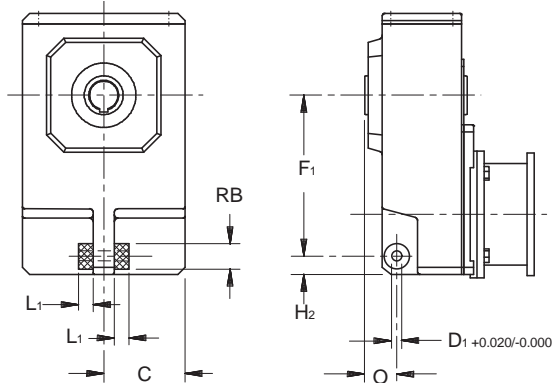

**Table No. 3 Metric output available on request**

Base Module	Standard Bore - inches			Optional Bore - mm			UC	UL	1
	U	UA	UB	U	UA	UB			
<b>F102</b>	.750	.187	.84	20 <sub>H7</sub>	6 <sub>JS9</sub>	22.8	1.38	2.87	3/8-16
<b>F202/F203</b>	1.000	.250	1.12	25 <sub>H7</sub>	8 <sub>JS9</sub>	28.3	1.77	3.62	1/2-13
<b>F302/F303</b>	1.250	.250	1.37	30 <sub>H7</sub>	8 <sub>JS9</sub>	33.3	1.97	4.06	1/2-13
<b>F402/F403</b>	1.500	.375	1.67	40 <sub>H7</sub>	12 <sub>JS9</sub>	43.3	2.17	4.49	3/4-10
<b>F602/F603</b>	2.000	.500	2.23	40 <sub>H7</sub>	14 <sub>JS9</sub>	53.8	2.76	5.63	3/4-10

**Table No. 4 Motor Adapter Dimensions (Inches)**

Base Module	MR140/050		MR160/140 <sup>2)</sup>		MR200/180		MR250/210 <sup>3)</sup>		Approx. Wt. lbs.
	C	L	C	L	C	L	C	L	
<b>F102</b>	7.40	4.09	8.11	4.25	—	—	—	—	38
<b>F202</b>	8.15	4.84	8.86	5.00	9.88	5.08	—	—	51
<b>F203</b>	9.61	6.30	—	—	—	—	—	—	64
<b>F302</b>	8.74	5.43	9.45	5.59	10.47	5.67	—	—	67
<b>F303</b>	10.20	6.89	11.14	7.28	—	—	—	—	73
<b>F402</b>	—	—	10.04	6.18	11.06	6.26	11.68	6.38	84
<b>F403</b>	10.79	7.48	11.73	7.87	—	—	—	—	91
<b>F602</b>	—	—	11.34	7.48	12.36	7.56	12.99	7.68	165
<b>F603</b>	—	—	13.03	9.17	—	—	—	—	177

<sup>2)</sup> Also available as **MR160/050** for a NEMA 56C frame motor.  
<sup>3)</sup> Also available as **MR250/180** for a NEMA 182/184TC frame motor.  
 All weights are approximate.

**Table No. 5**

Base Module	Part No.
F1	<b>25192</b>
F2	<b>25192</b>
F3	<b>25193</b>
F4	<b>25193</b>
F6	<b>25194</b>

Order two (2) rubber buffers for each unit.  
 Torque arms are not supplied by STÖBER.





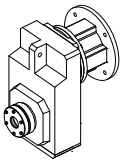

# "F" Series – MGS Reducer Tapped Holes – "G" Housing Single Bushing – Dimensional Data

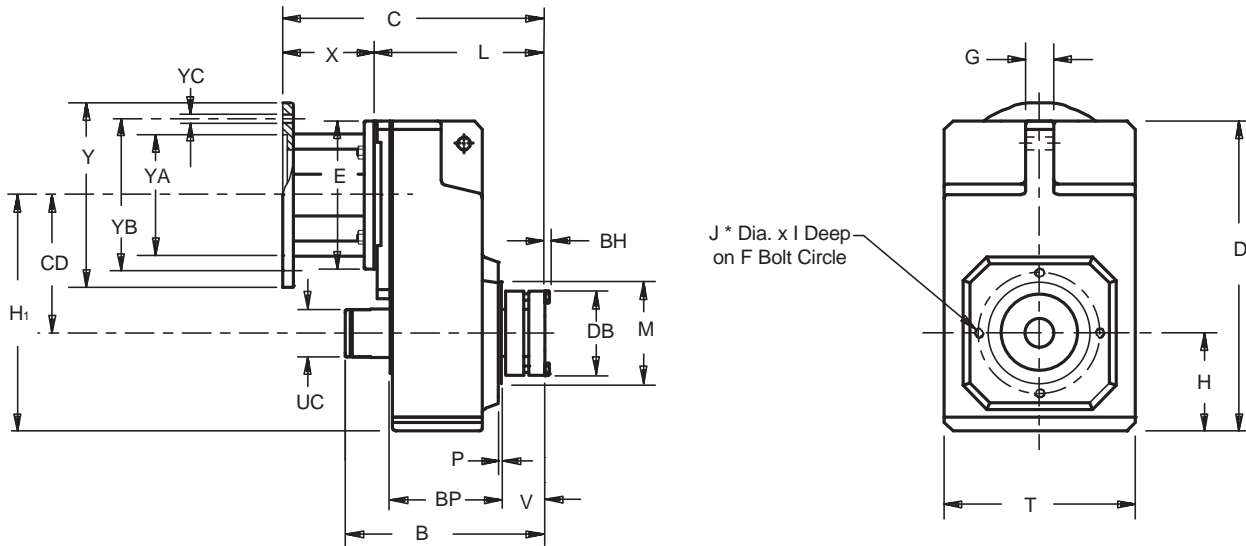

**Important:** For ease of installation, a 1/32 x 45° chamfer (minimum) is recommended for the output shaft end.

**Table No. 1 "F" Series – Single Side Wobble Free Bushing Unit Dimensions (Inches)**

Base Module	CD	B	D	F	G	H	H <sub>1</sub>	I	J *	M	P	T	V	BH	BP	DB	UC	Bushing Capscrews			
																		No. –	Size	Tight Torque	
																		Metric	in. lbs	Nm	
<b>F102</b>	4.02	6.40	9.37	3.54	.79	2.91	6.93	.51	M8	2.953	.10	5.71	1.18	.16	3.43	2.68	1.35	6 –	M6x25	89	10
<b>F202/F203</b>	5.16	7.26	11.77	4.53	.87	3.66	8.82	.51	M8	3.740	.12	7.09	1.54	.16	4.13	3.07	1.74	8 –	M6x30	89	10
<b>F302/F303</b>	5.89	7.95	13.23	5.12	1.18	4.17	10.06	.63	M10	4.331	.14	8.11	1.54	.16	4.72	3.31	1.90	8 –	M6x30	89	10
<b>F402/F403</b>	6.65 <sup>1)</sup>	8.93	14.57	5.12	1.18	4.57	11.22	.63	M10	4.331	.14	9.06	1.78	.20	5.31	3.82	2.14	8 –	M8x30	221	25
<b>F602/F603</b>	7.72	10.24	17.64	6.50	1.38	5.39	13.11	.63	M10	5.118	.14	10.43	1.77	.24	6.54	4.13	2.53	8 –	M10x35	434	49

\*F602 and F603 has 8 tapped holes instead of 4 as shown on drawing.

<sup>1)</sup> C.D. is 5.19 for F403 with MR160/050 or MR160/140 input.

**Table No. 2 "F" Series Unit Dimensions (Inches)**

Motor Adapter	NEMA C-Flange	E	X	Y	YA	YB	YC	Wt. lbs.
<b>MR140/050</b>	56C	5.51	3.31	6.50	4.500	5.87	.41	9
<b>MR160/050</b>	56C	6.30	3.86	6.50	4.500	5.87	.41	16
<b>MR160/140</b>	143/145TC	6.30	3.86	6.50	4.500	5.87	.41	16
<b>MR200/180</b>	182/184TC	7.87	4.80	9.00	8.500	7.25	.55	23
<b>MR250/180</b>	182/184TC	9.84	5.31	9.00	8.500	7.25	.55	36
<b>MR250/210</b>	213/215TC	9.84	5.31	9.00	8.500	7.25	.55	36

**Table No. 3 Motor Adapter Dimensions (Inches)**

Base Module	MR140/050		MR160/140 <sup>2)</sup>		MR200/180		MR250/210 <sup>3)</sup>		Wt. lbs.
	C	L	C	L	C	L	C	L	
<b>F102</b>	8.42	5.11	9.13	5.27	—	—	—	—	38
<b>F202</b>	9.50	6.19	10.21	6.35	11.23	6.43	—	—	51
<b>F203</b>	10.96	7.65	—	—	—	—	—	—	64
<b>F302</b>	10.09	6.78	10.80	6.94	11.82	7.02	—	—	67
<b>F303</b>	11.55	8.24	12.49	8.63	—	—	—	—	73
<b>F402</b>	—	—	11.63	7.77	12.65	7.85	13.28	7.97	84
<b>F403</b>	12.38	9.07	13.32	9.46	—	—	—	—	91
<b>F602</b>	—	—	12.84	8.98	13.86	9.06	14.49	9.18	165
<b>F603</b>	—	—	14.53	10.67	—	—	—	—	177

**Part No. Example**

Unit with Motor Adapter and 1 3/8" Bore Single Bushing  
**F402WG0560 MR160/140 WF4-106**

**Table No. 4 "WF" Single Side Bushings**

Base Module	Stock Bore Sizes													
	3/4	1	1 1/16	1 1/4	1 3/8	1 7/16	1 1/2	1 5/8	1 11/16	1 3/4	1 7/8	1 15/16	2	
<b>F102</b>	<b>WF1-075</b>	—	—	—	—	—	—	—	—	—	—	—	—	
<b>F202/F203</b>	—	<b>WF2-100</b>	<b>WF2-103</b>	—	—	—	—	—	—	—	—	—	—	
<b>F302/F303</b>	—	<b>WF3-100</b>	<b>WF3-103</b>	<b>WF3-104</b>	<b>WF3-106</b>	<b>WF3-107</b>	<b>WF3-108</b>	—	—	—	—	—	—	
<b>F402/F403</b>	—	<b>WF4-100</b>	<b>WF4-103</b>	<b>WF4-104</b>	<b>WF4-106</b>	<b>WF4-107</b>	<b>WF4-108</b>	—	—	—	—	—	—	
<b>F602/F603</b>	—	—	—	—	—	<b>WF5-107</b>	<b>WF5-108</b>	<b>WF5-110</b>	<b>WF5-111</b>	<b>WF5-112</b>	<b>WF5-114</b>	<b>WF5-115</b>	<b>WF5-200</b>	

<sup>2)</sup> Also available as **MR160/050** for a NEMA 56C frame motor.

<sup>3)</sup> Also available as **MR250/180** for a NEMA 182/184TC frame motor.

A complete bushing kit includes the locking ring assembly, tapered cone, support ring, and all hardware to mount the kit into the MGS reducer.

The bushing will accept a shaft with a tolerance of +.000/-0.005.

**NOTE: F6 units use a WF5 Bushing Kit.**

All weights are approximate.



# "F" Series – MGS Reducer Tapped Holes – "G" Housing Double Bushing – Dimensional Data

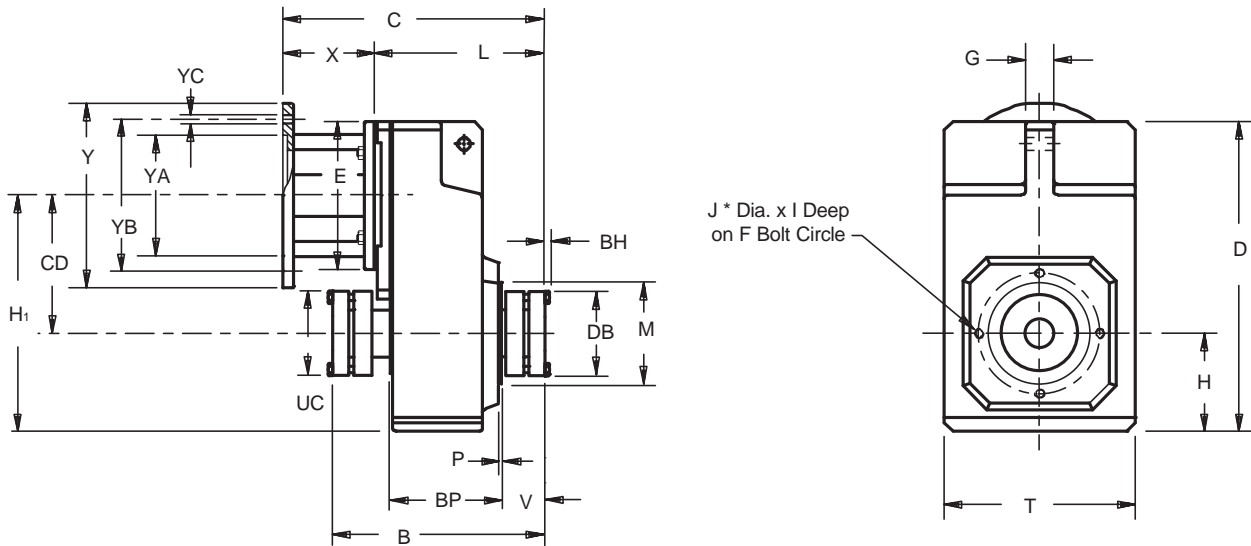
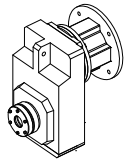

**Important:** For ease of installation, a 1/32 x 45° chamfer (minimum) is recommended for the output shaft end.

**Table No. 1 "F" Series – Double Side Wobble Free Bushing Unit Dimensions (Inches)**

Base Module	CD	B	D	F	G	H	H <sub>1</sub>	I	J*	M	P	T	V	BH	BP	DB	Bushing Capscrews		
																	No. – Size	Tight Torque	
																	Metric	in. lbs	Nm
<b>F102</b>	4.02	6.73	9.37	3.54	.79	2.91	6.93	.51	M8	2.953	.10	5.71	1.18	.16	3.43	2.68	6 – M6x25	89	10
<b>F202</b>	5.16	7.77	11.77	4.53	.87	3.66	8.82	.51	M8	3.740	.12	7.09	1.54	.16	4.13	3.07	8 – M6x30	89	10
<b>F302</b>	5.89	8.46	13.23	5.12	1.18	4.17	10.06	.63	M10	4.331	.14	8.11	1.54	.16	4.72	3.31	8 – M6x30	89	10
<b>F402</b>	6.65 <sup>1)</sup>	9.57	14.57	5.12	1.18	4.57	11.22	.63	M10	4.331	.14	9.06	1.78	.20	5.31	3.82	8 – M8x30	221	25
<b>F602</b>	7.72	10.84	17.64	6.50	1.38	5.39	13.11	.63	M10	5.118	.14	10.43	1.77	.24	6.54	4.13	8 – M10x35	434	49

\*F602 has 8 tapped holes instead of 4 as shown on drawing.

<sup>1)</sup> C.D. is 5.19 for F403 with MR160/050 or MR160/140 input.

**Table No. 2 "F" Series Unit Dimensions (Inches)**

Motor Adapter	NEMA C-Flange	E	X	Y	YA	YB	YC	Wt. lbs.
<b>MR140/050</b>	56C	5.51	3.31	6.50	4.500	5.87	.41	9
<b>MR160/050</b>	56C	6.30	3.86	6.50	4.500	5.87	.41	16
<b>MR160/140</b>	143/145TC	6.30	3.86	6.50	4.500	5.87	.41	16
<b>MR200/180</b>	182/184TC	7.87	4.80	9.00	8.500	7.25	.55	23
<b>MR250/180</b>	182/184TC	9.84	5.31	9.00	8.500	7.25	.55	36
<b>MR250/210</b>	213/215TC	9.84	5.31	9.00	8.500	7.25	.55	36

**Table No. 3 Motor Adapter Dimensions (Inches)**

Base Module	MR140/050		MR160/140 <sup>2)</sup>		MR200/180		MR250/210 <sup>3)</sup>		Wt. lbs.
	C	L	C	L	C	L	C	L	
<b>F102</b>	8.42	5.11	—	—	—	—	—	—	38
<b>F202</b>	9.50	6.19	10.21	6.35	—	—	—	—	51
<b>F302</b>	10.09	6.78	10.80	6.94	11.82	7.02	—	—	67
<b>F402</b>	—	—	11.63	7.77	12.65	7.85	—	—	84
<b>F602</b>	—	—	12.84	8.98	13.86	9.06	14.49	9.18	165

**Part No. Example**

Unit with Motor Adapter and 1 3/8" Bore Double Bushing

**F402WG0560 MR160/140 WFN4-106**

(WFN bushings do not have covers.)

**Table No. 4 "WFN" Double Side Bushings without Covers**

Unit	Stock Bores Sizes													
	3/4	1	1 3/16	1 1/4	1 3/8	1 7/16	1 1/2	1 5/8	1 11/16	1 3/4	1 7/8	1 15/16	2	
<b>F102</b>	WFN1-075	—	—	—	—	—	—	—	—	—	—	—	—	
<b>F202</b>	—	WFN2-100	WFN2-103	—	—	—	—	—	—	—	—	—	—	
<b>F302</b>	—	WFN3-100	WFN3-103	WFN3-104	WFN3-106	WFN3-107	WFN3-108	—	—	—	—	—	—	
<b>F402</b>	—	WFN4-100	WFN4-103	WFN4-104	WFN4-106	WFN4-107	WFN4-108	—	—	—	—	—	—	
<b>F602</b>	—	—	—	—	—	WFN5-107	WFN5-108	WFN5-110	WFN5-111	WFN5-112	WFN5-114	WFN5-115	WFN5-200	

<sup>2)</sup> Also available as **MR160/050** for a NEMA 56C frame motor.

<sup>3)</sup> Also available as **MR250/180** for a NEMA 182/184TC frame motor.

A complete bushing kit includes the locking ring assembly, tapered cone, support ring, and all hardware to mount the kit into the MGS reducer.

The bushing will accept a shaft with a tolerance of +.000/-0.005.

**NOTE: F6 units use a WFN5 Bushing Kit.**

All weights are approximate.



# **“K” Series Right Angle Helical/Bevel Speed Reducers**

**3 YEAR WARRANTY STANDARD**



**5 YEAR WARRANTY OPTIONAL**

**3-DAY  
DELIVERY**



[www.stober.com](http://www.stober.com)



MEX (55) 53 63 23 31 MTY (81) 83 54 10 18  
QRO (442) 1 95 72 60 ventas@industrialmagza.com



# "K" Series – Right Angle Helical/Bevel MGS Reducers



Right angle helical/bevel gear drives offer higher input-to-output efficiencies than conventional worm gear drives. This added efficiency reduces your costs today through smaller gear drive and motor sizing. Tomorrow, you'll benefit through optimum energy savings.

**Performance Specifications:**

- Horsepower ratings from 1/8 to 165
- Output torques to 106,296 in. lbs.
- Output speeds available from 437 to 4.5 RPM
- Speed reducer ratios from 4:1 to 381:1
- 3 year warranty – your assurance of satisfactory product performance



Strategically located oil fill, drain and breather ports for optimum mounting flexibility. Oil sight glass available.

**Input Options:**

- Input shaft
- NEMA C-face Adapter (coupling type)

Stainless steel nameplate and hardware

High efficiency spiral bevel gearing provides quiet operation and excellent torque carrying capacity

High quality helical gearing is case hardened to 58-62 Rockwell C. Precision finished for low noise and long service life. Standard backlash is  $\leq 12$  arc minutes

**Output Options:**

- Solid shaft
- Hollow
- Wobble free bushings

Double lip seals keep oil in and contaminants out. Double seals available for severe duty applications.

One-piece cast iron housing with precision machined bearing supports assure gearset alignment, prolongs bearing life, provides exceptional overhung load capacities, and eliminates leakage problems common to drives with bolt-on output covers.

Shipped with the proper amount and type of oil to prevent gear damaging dry start-ups.



MEX (55) 53 63 23 31 MTY (81) 83 54 10 18  
 QRO (442) 1 95 72 60 ventas@industrialmagza.com

STOBER Drives Inc. • MGS2007 • www.stober.com





# "K" Series – Right Angle Helical/Bevel MGS Speed Reducers Overview

## Output Style + Housing Style + Input Style = Reducer Configurations

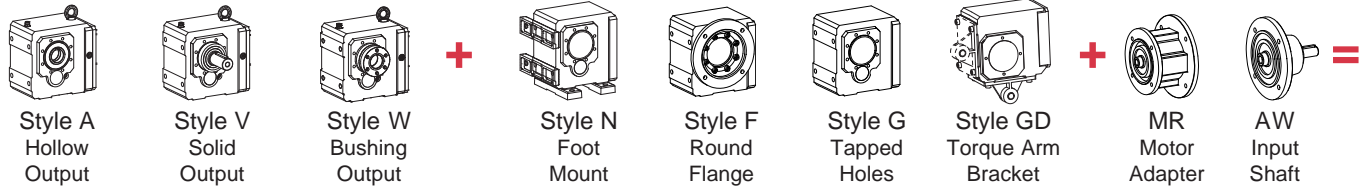

## Reducer Configurations (See Page 170 for AW Input Shaft.)

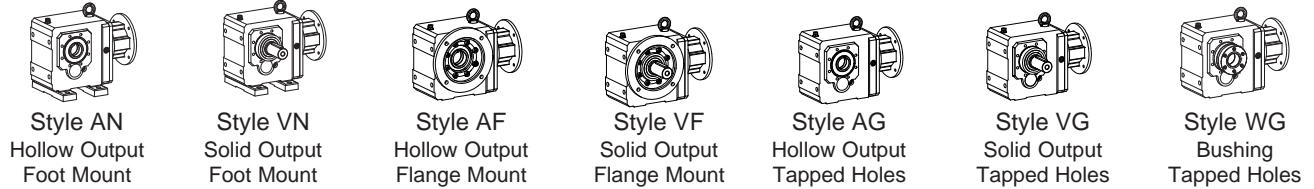

## Mounting Positions – Standard 3 Year Warranty

Mounting Position **MUST BE SPECIFIED.** (See Page 180 for more details.)

Standard Oil: Mobile XP600

Optional Oil: Food Grade Oil (Exxon Univis Special Mist 220)

Synthetic Oil (Mobil SHC630)

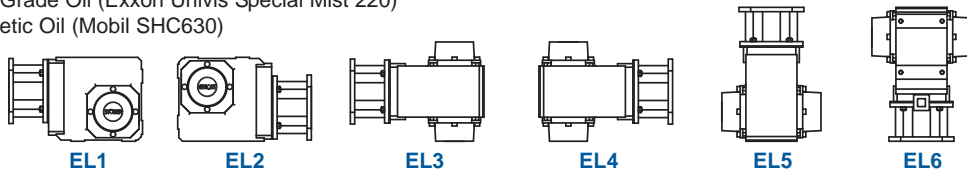

## Mounting Positions – Long Life 5 Year Warranty

Mounting Position **MUST BE SPECIFIED.** (See Page 180 for more details.)

Standard Oil: Synthetic Oil (Mobil SHC630)

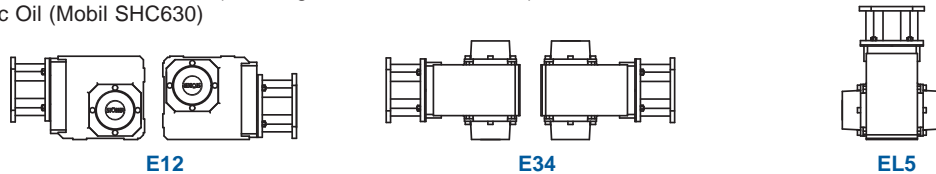

## Part No. Explanation with OPTIONS

**K 6 1 3 A GD 0580 MR160 / 140 LL E12**

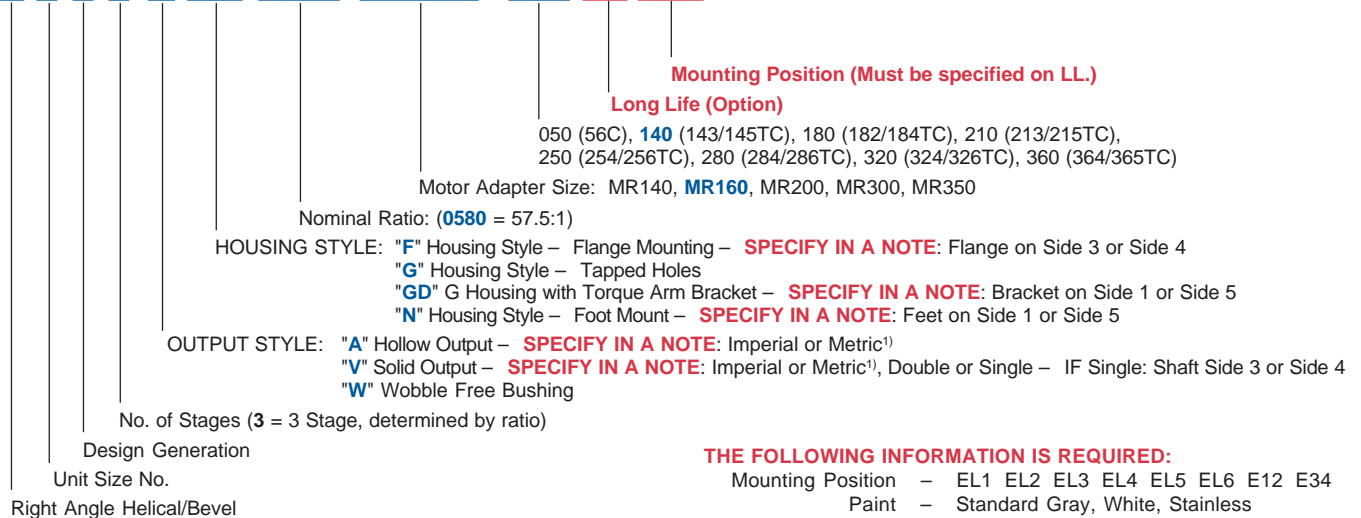

### THE FOLLOWING INFORMATION IS REQUIRED:

- Mounting Position – EL1 EL2 EL3 EL4 EL5 EL6 E12 E34
- Paint – Standard Gray, White, Stainless
- Shaft Side – Side 3 or Side 4
- Flange Side – Side 3 or Side 4
- Feet Side – Side 1 or Side 5 (Also Side 2 on K1)
- Torque Arm Bracket – Side 1 or Side 5 (Also Side 2 on K1)
- <sup>1)</sup> – Metric not available in all sizes.



# "K" Series – Right Angle Helical/Bevel MGS Reducer – Selection Data



## Selection Procedure:

- Under the Input RPM heading, find **Approximate Output RPM** nearest the requirement.
- In the **Input HP** column locate the rating that is greater than or equal to the required HP.  
(If selection is based on Torque instead of HP, find an **Output Torque** that is equal to or greater than required.)
- When HP or Torque rating is located, read across that row to select the **Base Module**, **Input Option** and **Overhung Loads**.
- If exact **Output RPM** is required, divide the **Input RPM** by the **Exact Ratio**.

1750 RPM Input		Base Module <sup>1)</sup>	Input Options <sup>2)</sup>			Exact Ratio	Overhung Load Output Shaft <sup>3)</sup> lbs.	1450 RPM Input		1160 RPM Input		870 RPM Input	
Input HP	Output Torque in. lbs.		Motor Adapter	NEMA C-Frame Size <sup>4)</sup>	Input Shaft			Input HP	Output Torque in. lbs.	Input HP	Output Torque in. lbs.	Input HP	Output Torque in. lbs.
<b>435 RPM Output (Approximate)</b>													
2.64	369	K102_0040	MR140/050	56C	AW140/010	4.000	520	2.19	369	1.75	369	1.31	369
2.81	392	K202_0040	MR140/050	56C	AW140/010	4.000	624	2.32	392	1.86	392	1.39	392
3.83*	536	K102_0040	MR160/050	56C	AW160/012	4.000	520	3.38	570	2.91	614	2.41	676
3.83*	536	K102_0040	MR160/140	143/145TC	AW160/012	4.000	520	3.38	570	2.91	614	2.41	676
6.84*	957	K202_0040	MR160/050	56C	AW160/012	4.000	624	6.04	1,018	5.20	1,097	4.29	1,207
6.84*	957	K202_0040	MR160/140	143/145TC	AW160/012	4.000	624	6.04	1,018	5.20	1,097	4.29	1,207
6.84*	957	K202_0040	MR200/180	182/184/TC	AW200/014	4.000	624	6.04	1,018	5.20	1,097	4.29	1,207
9.84*	1,375	K302_0040	MR160/050	56C	AW160/012	4.000	728	8.15	1,375	6.52	1,375	4.89	1,375
9.84*	1,375	K302_0040	MR160/140	143/145TC	AW160/012	4.000	728	8.15	1,375	6.52	1,375	4.89	1,375
9.84	1,375	K402_0040	MR160/050	56C	AW160/012	4.000	1,165	8.15	1,375	6.52	1,375	4.89	1,375
9.84	1,375	K402_0040	MR160/140	143/145TC	AW160/012	4.000	1,165	8.15	1,375	6.52	1,375	4.89	1,375
11.99*	1,675	K302_0040	MR200/180	182/184/TC	AW200/014	4.000	728	10.57	1,784	9.11	1,921	7.52	2,115
17.99*	2,514	K402_0040	MR200/180	182/184/TC	AW200/014	4.000	1,165	15.87	2,677	13.67	2,883	11.29	3,173
17.99*	2,514	K402_0040	MR250/180	182/184/TC	AW250/102	4.000	1,165	15.87	2,677	13.67	2,883	11.29	3,173

<b>400 RPM Output (Approximate)</b>													
2.78	423	K202_0044	MR140/050	56C	AW140/010	4.364	638	2.30	423	1.84	423	1.38	423
6.46*	985	K202_0044	MR160/050	56C	AW160/012	4.364	638	5.70	1,048	4.91	1,129	4.05	1,243
6.46*	985	K202_0044	MR160/140	143/145TC	AW160/012	4.364	638	5.70	1,048	4.91	1,129	4.05	1,243
6.46*	985	K202_0044	MR200/180	182/184/TC	AW200/014	4.364	638	5.70	1,048	4.91	1,129	4.05	1,243
9.84*	1,500	K302_0044	MR160/050	56C	AW160/012	4.364	744	8.15	1,500	6.52	1,500	4.89	1,500
9.84*	1,500	K302_0044	MR160/140	143/145TC	AW160/012	4.364	744	8.15	1,500	6.52	1,500	4.89	1,500
9.84	1,500	K402_0044	MR160/050	56C	AW160/012	4.364	1,191	8.15	1,500	6.52	1,500	4.89	1,500
9.84	1,500	K402_0044	MR160/140	143/145TC	AW160/012	4.364	1,191	8.15	1,500	6.52	1,500	4.89	1,500
11.31*	1,725	K302_0044	MR200/180	182/184/TC	AW200/014	4.364	744	9.98	1,836	8.60	1,978	7.10	2,177
16.97*	2,588	K402_0044	MR200/180	182/184/TC	AW200/014	4.364	1,191	14.97	2,755	12.90	2,968	10.65	3,267
16.97*	2,588	K402_0044	MR250/180	182/184/TC	AW250/102	4.364	1,191	14.97	2,755	12.90	2,968	10.65	3,267

<b>335 RPM Output (Approximate)</b>													
5.76*	1,042	K202_0052	MR160/050	56C	AW160/012	5.177	666	5.08	1,110	4.38	1,196	3.62	1,316
5.76*	1,042	K202_0052	MR160/140	143/145TC	AW160/012	5.177	666	5.08	1,110	4.38	1,196	3.62	1,316
5.76*	1,042	K202_0052	MR200/180	182/184/TC	AW200/014	5.177	666	5.08	1,110	4.38	1,196	3.62	1,316

<b>325 RPM Output (Approximate)</b>													
9.84*	1,847	K302_0054	MR160/050	56C	AW160/012	5.375	784	8.15	1,847	6.52	1,847	4.89	1,847
9.84*	1,847	K302_0054	MR160/140	143/145TC	AW160/012	5.375	784	8.15	1,847	6.52	1,847	4.89	1,847
9.84	1,863	K402_0054	MR160/050	56C	AW160/012	5.422	1,257	8.15	1,863	6.52	1,863	4.89	1,863
9.84	1,863	K402_0054	MR160/140	143/145TC	AW160/012	5.422	1,257	8.15	1,863	6.52	1,863	4.89	1,863
9.84*	1,849	K302_0054	MR200/180	182/184/TC	AW200/014	5.375	784	8.68	1,968	7.48	2,120	6.14	2,319
14.69*	2,782	K402_0054	MR200/180	182/184/TC	AW200/014	5.422	1,257	12.96	2,962	11.16	3,191	9.22	3,512
14.69*	2,782	K402_0054	MR250/180	182/184/TC	AW250/102	5.422	1,257	12.96	2,962	11.16	3,191	9.22	3,512

\* For thermal HP capacity, see rating below.

Base Module	K1	K2	K3	K4	K5	K6	K7	K8	K9	K10
Thermal Capacity	2.95	5.36	7.38	12.34	14.75	20.12	29.50	40.23	53.64	67.05

NEMA Frame Size  
TEFC 1750 RPM

C-Frame	Motor HP
56C	1/3 - 1 1/2
143/145TC	1, 1 1/2, 2
182/184TC	3, 5
213/215TC	7 1/2, 10
254/256TC	15, 20
284/286TC	25, 30
324/326TC	40, 50
364/365TC	60, 75

## Housing Styles

N – Foot Mounted    F – Round Flange    G – Tapped Holes    GD – Torque Arm Bracket

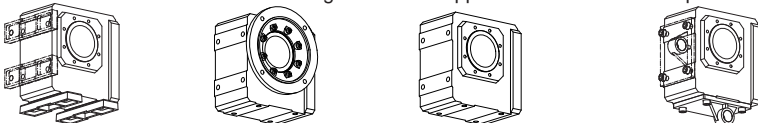

These Housing Styles are available as Hollow (A) or Solid (V) Output.



# "K" Series – Right Angle Helical/Bevel MGS Reducer – Selection Data



- NOTE:** 1) Complete Base Module Part Number by adding Output and Housing Style. Example: K302VG0560.  
 2) Select Input Option and add to completed Part Number. See example below.  
 3) Overhung Load is measured at the center of the shaft extension. Hollow output units are not intended to support overhung loads. If a load rating is required, use 50% of the published overhung load.  
 4) Other frame sizes may also be available. See dimension pages.

1750 RPM Input		Base Module <sup>1)</sup>	Input Options <sup>2)</sup>			Exact Ratio	Overhung Load Output Shaft <sup>3)</sup> lbs.	1450 RPM Input		1160 RPM Input		870 RPM Input	
Input HP	Output Torque in. lbs.		Motor Adapter	NEMA C-Frame Size <sup>4)</sup>	Input Shaft			Input HP	Output Torque in. lbs.	Input HP	Output Torque in. lbs.	Input HP	Output Torque in. lbs.
<b>315 RPM Output (Approximate)</b>													
2.64	514	K102_0056	MR140/050	56C	AW140/010	5.568	565	2.19	514	1.75	514	1.31	514
3.07*	598	K102_0056	MR160/050	56C	AW160/012	5.568	565	2.71	637	2.34	686	1.93	755
3.07*	598	K102_0056	MR160/140	143/145TC	AW160/012	5.568	565	2.71	637	2.34	686	1.93	755
<b>290 RPM Output (Approximate)</b>													
2.50	524	K102_0060	MR140/050	56C	AW140/010	6.000	576	2.07	524	1.66	524	1.24	524
2.78	582	K202_0060	MR140/050	56C	AW140/010	6.000	691	2.30	582	1.84	582	1.38	582
2.92	613	K102_0060	MR160/050	56C	AW160/012	6.000	576	2.58	653	2.22	703	1.84	774
2.92	613	K102_0060	MR160/140	143/145TC	AW160/012	6.000	576	2.58	653	2.22	703	1.84	774
5.22	1,095	K202_0060	MR160/050	56C	AW160/012	6.000	691	4.61	1,166	3.97	1,256	3.28	1,382
5.22	1,095	K202_0060	MR160/140	143/145TC	AW160/012	6.000	691	4.61	1,166	3.97	1,256	3.28	1,382
5.22	1,095	K202_0060	MR200/180	182/184/TC	AW200/014	6.000	691	4.61	1,166	3.97	1,256	3.28	1,382
9.15*	1,918	K302_0060	MR160/050	56C	AW160/012	6.000	806	8.07	2,042	6.52	2,062	4.89	2,062
9.15*	1,918	K302_0060	MR160/140	143/145TC	AW160/012	6.000	806	8.07	2,042	6.52	2,062	4.89	2,062
9.15*	1,918	K302_0060	MR200/180	182/184/TC	AW200/014	6.000	806	8.07	2,042	6.95	2,199	5.74	2,421
9.84	2,062	K402_0060	MR160/050	56C	AW160/012	6.000	1,290	8.15	2,062	6.52	2,062	4.89	2,062
9.84	2,062	K402_0060	MR160/140	143/145TC	AW160/012	6.000	1,290	8.15	2,062	6.52	2,062	4.89	2,062
13.73*	2,878	K402_0060	MR200/180	182/184/TC	AW200/014	6.000	1,290	12.11	3,064	10.44	3,301	8.61	3,633
13.73*	2,878	K402_0060	MR250/180	182/184/TC	AW250/102	6.000	1,290	12.11	3,064	10.44	3,301	8.61	3,633
<b>260 RPM Output (Approximate)</b>													
2.46	571	K102_0066	MR140/050	56C	AW140/010	6.644	591	2.04	571	1.63	571	1.22	571
2.61	610	K202_0067	MR140/050	56C	AW140/010	6.683	710	2.16	610	1.73	610	1.30	610
2.73	634	K102_0066	MR160/050	56C	AW160/012	6.644	591	2.41	675	2.08	728	1.71	801
2.73	634	K102_0066	MR160/140	143/145TC	AW160/012	6.644	591	2.41	675	2.08	728	1.71	801
4.86	1,135	K202_0067	MR160/050	56C	AW160/012	6.683	710	4.29	1,208	3.70	1,302	3.05	1,433
4.86	1,135	K202_0067	MR160/140	143/145TC	AW160/012	6.683	710	4.29	1,208	3.70	1,302	3.05	1,433
4.86	1,135	K202_0067	MR200/180	182/184/TC	AW200/014	6.683	710	4.29	1,208	3.70	1,302	3.05	1,433
8.46*	1,994	K302_0067	MR160/050	56C	AW160/012	6.740	830	7.47	2,123	6.44	2,286	4.89	2,316
8.46*	1,994	K302_0067	MR160/140	143/145TC	AW160/012	6.740	830	7.47	2,123	6.44	2,286	4.89	2,316
8.46*	1,994	K302_0067	MR200/180	182/184/TC	AW200/014	6.740	830	7.47	2,123	6.44	2,286	5.31	2,517
9.84	2,309	K402_0067	MR160/050	56C	AW160/012	6.719	1,327	8.15	2,309	6.52	2,309	4.89	2,309
9.84	2,309	K402_0067	MR160/140	143/145TC	AW160/012	6.719	1,327	8.15	2,309	6.52	2,309	4.89	2,309
12.73*	2,988	K402_0067	MR200/180	182/184/TC	AW200/014	6.719	1,327	11.23	3,182	9.68	3,427	7.99	3,772
12.73*	2,988	K402_0067	MR250/180	182/184/TC	AW250/102	6.719	1,327	11.23	3,182	9.68	3,427	7.99	3,772
<b>245 RPM Output (Approximate)</b>													
4.66	1,159	K202_0071	MR160/050	56C	AW160/012	7.118	721	4.11	1,234	3.54	1,329	2.92	1,463
4.66	1,159	K202_0071	MR160/140	143/145TC	AW160/012	7.118	721	4.11	1,234	3.54	1,329	2.92	1,463
4.66	1,159	K202_0071	MR200/180	182/184/TC	AW200/014	7.118	721	4.11	1,234	3.54	1,329	2.92	1,463
<b>200 RPM Output (Approximate)</b>													
<b>160 RPM Output (Approximate)</b>													
<b>120 RPM Output (Approximate)</b>													

### Part No. Explanation

**K 4 0 2 V G 0690 AW 160 /012**

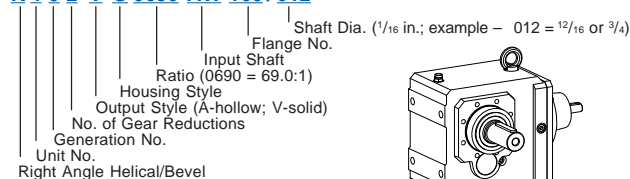

**K 4 0 2 V G 0690 MR 160 /140**

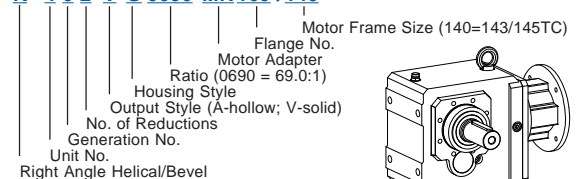

**Mounting position must be specified when ordering.**



# "K" Series – Right Angle Helical/Bevel MGS Reducer – Selection Data



### Selection Procedure:

- Under the Input RPM heading, find **Approximate Output RPM** nearest the requirement.
- In the **Input HP** column locate the rating that is greater than or equal to the required HP.  
(If selection is based on Torque instead of HP, find an **Output Torque** that is equal to or greater than required.)
- When HP or Torque rating is located, read across that row to select the **Base Module**, **Input Option** and **Overhung Loads**.
- If exact **Output RPM** is required, divide the **Input RPM** by the **Exact Ratio**.

1750 RPM Input		Base Module <sup>1)</sup>	Input Options <sup>2)</sup>			Exact Ratio	Overhung Load Output Shaft <sup>3)</sup> lbs.	1450 RPM Input		1160 RPM Input		870 RPM Input	
Input HP	Output Torque in. lbs.		Motor Adapter	NEMA C-Frame Size <sup>4)</sup>	Input Shaft			Input HP	Output Torque in. lbs.	Input HP	Output Torque in. lbs.	Input HP	Output Torque in. lbs.
<b>235 RPM Output (Approximate)</b>													
								<b>190 RPM</b>	<b>155 RPM</b>	<b>115 RPM</b>			
7.96*	2,056	<b>K302_0074</b>	<b>MR160/050</b>	56C	<b>AW160/012</b>	7.391	849	7.02	2,189	6.05	2,358	4.89	2,540
7.96*	2,056	<b>K302_0074</b>	<b>MR160/140</b>	143/145TC	<b>AW160/012</b>	7.391	849	7.02	2,189	6.05	2,358	4.89	2,540
7.96*	2,056	<b>K302_0074</b>	<b>MR200/180</b>	182/184/TC	<b>AW200/014</b>	7.391	849	7.02	2,189	6.05	2,358	5.00	2,595
9.84	2,563	<b>K402_0075</b>	<b>MR160/050</b>	56C	<b>AW160/012</b>	7.456	1,362	8.15	2,563	6.52	2,563	4.89	2,563
9.84	2,563	<b>K402_0075</b>	<b>MR160/140</b>	143/145TC	<b>AW160/012</b>	7.456	1,362	8.15	2,563	6.52	2,563	4.89	2,563
11.88	3,094	<b>K402_0075</b>	<b>MR200/180</b>	182/184/TC	<b>AW200/014</b>	7.456	1,362	10.48	3,294	9.03	3,548	7.45	3,906
11.88	3,094	<b>K402_0075</b>	<b>MR250/180</b>	182/184/TC	<b>AW250/102</b>	7.456	1,362	10.48	3,294	9.03	3,548	7.45	3,906
22.58*	5,710	<b>K513_0073</b>	<b>MR200/180</b>	182/184/TC	<b>AW200/014</b>	7.347	1,629	19.37	5,911	15.49	5,911	11.62	5,911
22.58*	5,710	<b>K513_0073</b>	<b>MR250/180</b>	182/184/TC	<b>AW250/102</b>	7.347	1,629	19.92	6,079	17.17	6,548	14.17	7,207
23.37*	5,891	<b>K613_0073</b>	<b>MR200/180</b>	182/184/TC	<b>AW200/014</b>	7.323	1,936	19.37	5,891	15.49	5,891	11.62	5,891
23.37	5,989	<b>K813_0074</b>	<b>MR200/180</b>	182/184/TC	<b>AW200/014</b>	7.445	3,524	19.37	5,989	15.49	5,989	11.62	5,989
23.37	6,084	<b>K713_0076</b>	<b>MR200/180</b>	182/184/TC	<b>AW200/014</b>	7.563	2,684	19.37	6,084	15.49	6,084	11.62	6,084
29.90	7,536	<b>K613_0073</b>	<b>MR250/210</b>	213/215/TC	<b>AW250/102</b>	7.323	1,936	26.38	8,024	22.73	8,644	18.12	9,189
29.90	7,536	<b>K613_0073</b>	<b>MR300/210</b>	213/215/TC	<b>AW300/110</b>	7.323	1,936	26.38	8,024	22.73	8,644	18.76	9,513
37.76	9,828	<b>K713_0076</b>	<b>MR250/210</b>	213/215/TC	<b>AW250/102</b>	7.563	2,684	31.28	9,828	25.03	9,828	18.77	9,828
39.64	10,157	<b>K813_0074</b>	<b>MR250/210</b>	213/215/TC	<b>AW250/102</b>	7.445	3,524	32.84	10,157	26.27	10,157	19.71	10,157
47.90*	12,467	<b>K713_0076</b>	<b>MR300/280</b>	284/286TC	<b>AW300/110</b>	7.563	2,684	42.25	13,274	36.41	14,299	30.06	15,738
75.74*	19,409	<b>K813_0074</b>	<b>MR300/250</b>	254/256TC	<b>AW300/110</b>	7.445	3,524	62.76	19,409	50.21	19,409	37.66	19,409
79.62*	21,741	<b>K913_0079</b>	<b>MR300/250</b>	254/256TC	<b>AW300/110</b>	7.934	8,025	65.97	21,741	52.77	21,741	39.58	21,741
<b>220 RPM Output (Approximate)</b>													
								<b>185 RPM</b>	<b>148 RPM</b>	<b>110 RPM</b>			
123.02*	33,594	<b>K913_0079</b>	<b>MR350/320</b>	324/326TC	<b>AW350/202</b>	7.934	8,025	101.93	33,594	81.55	33,594	61.16	33,594
123.02*	33,632	<b>K1013_0079</b>	<b>MR350/320</b>	324/326TC	<b>AW350/202</b>	7.943	9,880	101.93	33,632	81.55	33,632	61.16	33,632
<b>215 RPM Output (Approximate)</b>													
								<b>180 RPM</b>	<b>145 RPM</b>	<b>105 RPM</b>			
2.35	684	<b>K102_0083</b>	<b>MR140/050</b>	56C	<b>AW140/010</b>	8.309	625	1.97	689	1.57	689	1.18	689
2.35	684	<b>K102_0083</b>	<b>MR160/050</b>	56C	<b>AW160/012</b>	8.309	625	2.08	728	1.79	784	1.48	863
2.35	684	<b>K102_0083</b>	<b>MR160/140</b>	143/145TC	<b>AW160/012</b>	8.309	625	2.08	728	1.79	784	1.48	863
21.10*	5,907	<b>K513_0081</b>	<b>MR200/180</b>	182/184/TC	<b>AW200/014</b>	8.134	1,671	18.61	6,289	15.49	6,544	11.62	6,544
21.10*	5,907	<b>K513_0081</b>	<b>MR250/180</b>	182/184/TC	<b>AW250/102</b>	8.134	1,671	18.61	6,289	16.04	6,774	13.24	7,456
23.37	6,631	<b>K813_0082</b>	<b>MR200/180</b>	182/184/TC	<b>AW200/014</b>	8.243	3,615	19.37	6,631	15.49	6,631	11.62	6,631
23.37*	6,522	<b>K613_0081</b>	<b>MR200/180</b>	182/184/TC	<b>AW200/014</b>	8.107	1,986	19.37	6,522	15.49	6,522	11.62	6,522
27.94*	7,796	<b>K613_0081</b>	<b>MR250/180</b>	182/184/TC	<b>AW250/102</b>	8.107	1,986	24.65	8,301	21.24	8,942	17.53	9,841
27.94*	7,796	<b>K613_0081</b>	<b>MR300/280</b>	284/286TC	<b>AW300/110</b>	8.107	1,986	24.65	8,301	21.24	8,942	17.53	9,841
39.64	11,246	<b>K813_0082</b>	<b>MR250/180</b>	182/184/TC	<b>AW250/102</b>	8.243	3,615	32.84	11,246	26.27	11,246	19.71	11,246
75.74*	21,489	<b>K813_0082</b>	<b>MR300/210</b>	213/215/TC	<b>AW300/110</b>	8.243	3,615	62.76	21,489	50.21	21,489	37.66	21,489

\* For thermal HP capacity, see rating below.

Base Module	K1	K2	K3	K4	K5	K6	K7	K8	K9	K10
Thermal Capacity	2.95	5.36	7.38	12.34	14.75	20.12	29.50	40.23	53.64	67.05

NEMA Frame Size  
TEFC 1750 RPM

C-Frame	Motor HP
56C	1/3 - 1 1/2
143/145TC	1, 1 1/2, 2
182/184TC	3, 5
213/215TC	7 1/2, 10
254/256TC	15, 20
284/286TC	25, 30
324/326TC	40, 50
364/365TC	60, 75

### Housing Styles

**N** – Foot Mounted    **F** – Round Flange    **G** – Tapped Holes    **GD** – Torque Arm Bracket

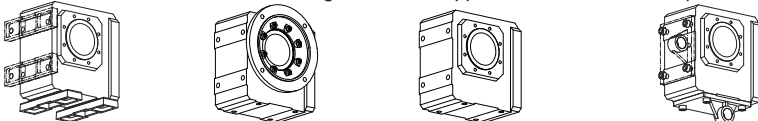

These Housing Styles are available as Hollow (A) or Solid (V) Output.





# "K" Series – Right Angle Helical/Bevel MGS Reducer – Selection Data



- NOTE:** 1) Complete Base Module Part Number by adding Output and Housing Style. Example: K302VG0560.  
 2) Select Input Option and add to completed Part Number. See example below.  
 3) Overhung Load is measured at the center of the shaft extension. Hollow output units are not intended to support overhung loads. If a load rating is required, use 50% of the published overhung load.  
 4) Other frame sizes may also be available. See dimension pages.

1750 RPM Input		Base Module <sup>1)</sup>	Input Options <sup>2)</sup>			Exact Ratio	Overhung Load Output Shaft <sup>3)</sup> lbs.	1450 RPM Input		1160 RPM Input		870 RPM Input	
Input HP	Output Torque in. lbs.		Motor Adapter	NEMA C-Frame Size <sup>4)</sup>	Input Shaft			Input HP	Output Torque in. lbs.	Input HP	Output Torque in. lbs.	Input HP	Output Torque in. lbs.
<b>210 RPM Output (Approximate)</b>													
								<b>170 RPM</b>	<b>140 RPM</b>	<b>105 RPM</b>			
2.52	740	K202_0084	MR140/050	56C	AW140/010	8.397	751	2.09	740	1.67	740	1.25	740
4.17	1,225	K202_0084	MR160/050	56C	AW160/012	8.397	751	3.68	1,304	3.17	1,405	2.62	1,546
4.17	1,225	K202_0084	MR160/140	143/145TC	AW160/012	8.397	751	3.68	1,304	3.17	1,405	2.62	1,546
4.17	1,225	K202_0084	MR200/180	182/184/TC	AW200/014	8.397	751	3.68	1,304	3.17	1,405	2.62	1,546
7.28	2,149	K302_0084	MR160/050	56C	AW160/012	8.444	878	6.43	2,288	5.54	2,465	4.57	2,713
7.28	2,149	K302_0084	MR160/140	143/145TC	AW160/012	8.444	878	6.43	2,288	5.54	2,465	4.57	2,713
7.28	2,149	K302_0084	MR200/180	182/184/TC	AW200/014	8.444	878	6.43	2,288	5.54	2,465	4.57	2,713
9.84	2,879	K402_0084	MR160/050	56C	AW160/012	8.377	1,402	8.15	2,879	6.52	2,879	4.89	2,879
9.84	2,879	K402_0084	MR160/140	143/145TC	AW160/012	8.377	1,402	8.15	2,879	6.52	2,879	4.89	2,879
10.99	3,216	K402_0084	MR200/180	182/184/TC	AW200/014	8.377	1,402	9.69	3,424	8.35	3,689	6.90	4,060
10.99	3,216	K402_0084	MR250/180	182/184/TC	AW250/102	8.377	1,402	9.69	3,424	8.35	3,689	6.90	4,060
23.37	6,736	K713_0084	MR200/180	182/184/TC	AW200/014	8.373	2,753	19.37	6,736	15.49	6,736	11.62	6,736
37.76*	10,881	K713_0084	MR250/210	213/215/TC	AW250/102	8.373	2,753	31.28	10,881	25.03	10,881	18.77	10,881
44.75*	12,897	K713_0084	MR300/250	254/256TC	AW300/110	8.373	2,753	39.48	13,732	34.02	14,792	28.09	16,281
<b>190 RPM Output (Approximate)</b>													
								<b>155 RPM</b>	<b>125 RPM</b>	<b>95 RPM</b>			
2.19	708	K102_0092	MR140/050	56C	AW140/010	9.249	641	1.93	754	1.63	795	1.22	795
2.19	708	K102_0092	MR160/050	56C	AW160/012	9.249	641	1.93	754	1.67	812	1.38	894
2.19	708	K102_0092	MR160/140	143/145TC	AW160/012	9.249	641	1.93	754	1.67	812	1.38	894
2.61	839	K202_0092	MR140/050	56C	AW140/010	9.190	769	2.16	839	1.73	839	1.30	839
3.93	1,262	K202_0092	MR160/050	56C	AW160/012	9.190	769	3.47	1,344	2.99	1,448	2.47	1,593
3.93	1,262	K202_0092	MR160/140	143/145TC	AW160/012	9.190	769	3.47	1,344	2.99	1,448	2.47	1,593
3.93	1,262	K202_0092	MR200/180	182/184/TC	AW200/014	9.190	769	3.47	1,344	2.99	1,448	2.47	1,593
6.85	2,217	K302_0093	MR160/050	56C	AW160/012	9.267	898	6.04	2,360	5.20	2,542	4.30	2,798
6.85	2,217	K302_0093	MR160/140	143/145TC	AW160/012	9.267	898	6.04	2,360	5.20	2,542	4.30	2,798
6.85	2,217	K302_0093	MR200/180	182/184/TC	AW200/014	9.267	898	6.04	2,360	5.20	2,542	4.30	2,798
9.84	3,175	K402_0092	MR160/050	56C	AW160/012	9.238	1,436	8.15	3,175	6.52	3,175	4.89	3,175
9.84	3,175	K402_0092	MR160/140	143/145TC	AW160/012	9.238	1,436	8.15	3,175	6.52	3,175	4.89	3,175
10.29	3,323	K402_0092	MR200/180	182/184/TC	AW200/014	9.238	1,436	9.08	3,538	7.83	3,811	6.46	4,195
10.29	3,323	K402_0092	MR250/180	182/184/TC	AW250/102	9.238	1,436	9.08	3,538	7.83	3,811	6.46	4,195
19.48*	6,147	K513_0092	MR200/180	182/184/TC	AW200/014	9.168	1,722	17.19	6,545	14.81	7,050	11.62	7,376
19.48*	6,147	K513_0092	MR250/210	213/215/TC	AW250/102	9.168	1,722	17.19	6,545	14.81	7,050	12.23	7,759
23.37	7,469	K813_0093	MR200/180	182/184/TC	AW200/014	9.284	3,724	19.37	7,469	15.49	7,469	11.62	7,469
23.37*	7,306	K613_0091	MR200/180	182/184/TC	AW200/014	9.081	2,043	19.37	7,306	15.49	7,306	11.62	7,306
23.37	7,392	K713_0092	MR200/180	182/184/TC	AW200/014	9.188	2,818	19.37	7,392	15.49	7,392	11.62	7,392
25.91*	8,097	K613_0091	MR250/180	182/184/TC	AW250/102	9.081	2,043	22.85	8,621	19.69	9,286	16.26	10,221
25.91*	8,097	K613_0091	MR300/210	213/215/TC	AW300/110	9.081	2,043	22.85	8,621	19.69	9,286	16.26	10,221
36.79*	11,634	K713_0092	MR250/180	182/184/TC	AW250/102	9.188	2,818	30.48	11,634	24.39	11,634	18.29	11,634
38.48	12,296	K813_0093	MR250/180	182/184/TC	AW250/102	9.284	3,724	31.88	12,296	25.51	12,296	19.13	12,296
42.07*	13,303	K713_0092	MR300/250	254/256TC	AW300/110	9.188	2,818	37.11	14,163	31.98	15,257	26.40	16,793
72.31*	23,107	K813_0093	MR300/250	254/256TC	AW300/110	9.284	3,724	60.93	23,496	48.74	23,496	36.56	23,496

### Part No. Explanation

**K 4 0 2 V G 0690 AW 160 /012**

Unit No.  
 Generation No.  
 No. of Gear Reductions  
 Output Style (A-hollow; V-solid)  
 Housing Style  
 Ratio (0690 = 69.0:1)  
 Input Shaft  
 Flange No.  
 Shaft Dia. (1/16 in.; example - 012 = 12/16 or 3/4)  
 Right Angle Helical/Bevel

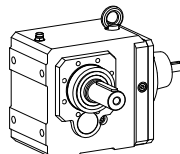

**K 4 0 2 V G 0690 MR 160 /140**

Unit No.  
 Generation No.  
 No. of Reductions  
 Output Style (A-hollow; V-solid)  
 Housing Style  
 Ratio (0690 = 69.0:1)  
 Motor Adapter  
 Flange No.  
 Motor Frame Size (140=143/145TC)  
 Right Angle Helical/Bevel

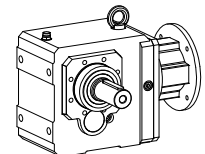

**Mounting position must be specified when ordering.**





# "K" Series – Right Angle Helical/Bevel MGS Reducer – Selection Data



### Selection Procedure:

- Under the Input RPM heading, find **Approximate Output RPM** nearest the requirement.
- In the **Input HP** column locate the rating that is greater than or equal to the required HP.  
(If selection is based on Torque instead of HP, find an **Output Torque** that is equal to or greater than required.)
- When HP or Torque rating is located, read across that row to select the **Base Module**, **Input Option** and **Overhung Loads**.
- If exact **Output RPM** is required, divide the **Input RPM** by the **Exact Ratio**.

1750 RPM Input		Base Module <sup>1)</sup>	Input Options <sup>2)</sup>			Exact Ratio	Overhung Load Output Shaft <sup>3)</sup> lbs.	1450 RPM Input		1160 RPM Input		870 RPM Input	
Input HP	Output Torque in. lbs.		Motor Adapter	NEMA C-Frame Size <sup>4)</sup>	Input Shaft			Input HP	Output Torque in. lbs.	Input HP	Output Torque in. lbs.	Input HP	Output Torque in. lbs.
<b>170 RPM Output (Approximate)</b>													
								<b>140 RPM</b>	<b>115 RPM</b>	<b>85 RPM</b>			
2.06	730	<b>K102_0100</b>	<b>MR140/050</b>	56C	<b>AW140/010</b>	10.140	656	1.82	778	1.52	814	1.14	814
2.06	730	<b>K102_0100</b>	<b>MR160/050</b>	56C	<b>AW160/012</b>	10.140	656	1.82	778	1.57	838	1.29	922
2.06	730	<b>K102_0100</b>	<b>MR160/140</b>	143/145TC	<b>AW160/012</b>	10.140	656	1.82	778	1.57	838	1.29	922
2.44	859	<b>K202_0100</b>	<b>MR140/050</b>	56C	<b>AW140/010</b>	10.073	786	2.02	859	1.62	859	1.21	859
3.70	1,301	<b>K202_0100</b>	<b>MR160/050</b>	56C	<b>AW160/012</b>	10.073	786	3.26	1,386	2.81	1,493	2.32	1,643
3.70	1,301	<b>K202_0100</b>	<b>MR160/140</b>	143/145TC	<b>AW160/012</b>	10.073	786	3.26	1,386	2.81	1,493	2.32	1,643
3.70	1,301	<b>K202_0100</b>	<b>MR200/180</b>	182/184/TC	<b>AW200/014</b>	10.073	786	3.26	1,386	2.81	1,493	2.32	1,643
6.45	2,284	<b>K302_0100</b>	<b>MR160/050</b>	56C	<b>AW160/012</b>	10.135	919	5.69	2,432	4.90	2,619	4.05	2,883
6.45	2,284	<b>K302_0100</b>	<b>MR160/140</b>	143/145TC	<b>AW160/012</b>	10.135	919	5.69	2,432	4.90	2,619	4.05	2,883
6.45	2,284	<b>K302_0100</b>	<b>MR200/180</b>	182/184/TC	<b>AW200/014</b>	10.135	919	5.69	2,432	4.90	2,619	4.05	2,883
9.70	3,423	<b>K402_0100</b>	<b>MR160/050</b>	56C	<b>AW160/012</b>	10.098	1,469	8.15	3,471	6.52	3,471	4.89	3,471
9.70	3,423	<b>K402_0100</b>	<b>MR160/140</b>	143/145TC	<b>AW160/012</b>	10.098	1,469	8.15	3,471	6.52	3,471	4.89	3,471
9.70	3,423	<b>K402_0100</b>	<b>MR200/180</b>	182/184/TC	<b>AW200/014</b>	10.098	1,469	8.56	3,645	7.38	3,926	6.09	4,321
9.70	3,423	<b>K402_0100</b>	<b>MR250/180</b>	182/184/TC	<b>AW250/102</b>	10.098	1,469	8.56	3,645	7.38	3,926	6.09	4,321
18.20*	6,359	<b>K513_0100</b>	<b>MR200/180</b>	182/184/TC	<b>AW200/014</b>	10.150	1,766	16.06	6,770	13.84	7,293	11.35	7,972
18.20*	6,359	<b>K513_0100</b>	<b>MR250/180</b>	182/184/TC	<b>AW250/102</b>	10.150	1,766	16.06	6,770	13.84	7,293	11.35	7,972
23.37*	8,088	<b>K613_0100</b>	<b>MR200/180</b>	182/184/TC	<b>AW200/014</b>	10.054	2,096	19.37	8,088	15.49	8,088	11.62	8,088
23.37*	8,183	<b>K713_0100</b>	<b>MR200/180</b>	182/184/TC	<b>AW200/014</b>	10.172	2,890	19.37	8,183	15.49	8,183	11.62	8,183
23.37	8,269	<b>K813_0105</b>	<b>MR200/180</b>	182/184/TC	<b>AW200/014</b>	10.279	3,820	19.37	8,269	15.49	8,269	11.62	8,269
24.21*	8,376	<b>K613_0100</b>	<b>MR250/210</b>	213/215/TC	<b>AW250/102</b>	10.054	2,096	21.35	8,918	18.40	9,607	15.19	10,574
24.21*	8,376	<b>K613_0100</b>	<b>MR300/210</b>	213/215/TC	<b>AW300/110</b>	10.054	2,096	21.35	8,918	18.40	9,607	15.19	10,574
36.79*	12,880	<b>K713_0100</b>	<b>MR250/180</b>	182/184/TC	<b>AW250/102</b>	10.172	2,890	30.48	12,880	24.39	12,880	18.29	12,880
38.48	13,614	<b>K813_0105</b>	<b>MR250/180</b>	182/184/TC	<b>AW250/102</b>	10.279	3,820	31.88	13,614	25.51	13,614	19.13	13,614
39.31*	13,762	<b>K713_0100</b>	<b>MR300/250</b>	254/256TC	<b>AW300/110</b>	10.172	2,890	34.68	14,652	29.88	15,783	24.67	17,372
67.57*	23,904	<b>K813_0105</b>	<b>MR300/250</b>	254/256TC	<b>AW300/110</b>	10.279	3,820	59.61	25,451	48.74	26,014	36.56	26,014
77.05*	26,830	<b>K913_0100</b>	<b>MR300/280</b>	284/286TC	<b>AW300/110</b>	10.117	8,528	63.84	26,830	51.07	26,830	38.31	26,830
123.02*	42,282	<b>K1013_0100</b>	<b>MR350/320</b>	324/326TC	<b>AW350/202</b>	9.986	10,462	101.93	42,282	81.55	42,282	61.16	42,282
123.02*	42,837	<b>K913_0100</b>	<b>MR350/360</b>	364/365TC	<b>AW350/202</b>	10.117	8,528	101.93	42,837	81.55	42,837	61.16	42,837

<b>150 RPM Output (Approximate) Continued Next Page</b>													
								<b>125 RPM</b>	<b>100 RPM</b>	<b>75 RPM</b>			
1.89	763	<b>K102_0115</b>	<b>MR140/050</b>	56C	<b>AW140/010</b>	11.565	678	1.67	813	1.44	875	1.18	959
1.89	763	<b>K102_0115</b>	<b>MR160/050</b>	56C	<b>AW160/012</b>	11.565	678	1.67	813	1.44	875	1.19	963
1.89	763	<b>K102_0115</b>	<b>MR160/140</b>	143/145TC	<b>AW160/012</b>	11.565	678	1.67	813	1.44	875	1.19	963
2.52	1,017	<b>K202_0115</b>	<b>MR140/050</b>	56C	<b>AW140/010</b>	11.546	814	2.09	1,017	1.67	1,017	1.25	1,017
3.38	1,362	<b>K202_0115</b>	<b>MR160/050</b>	56C	<b>AW160/012</b>	11.546	814	2.98	1,450	2.57	1,562	2.12	1,719
3.38	1,362	<b>K202_0115</b>	<b>MR160/140</b>	143/145TC	<b>AW160/012</b>	11.546	814	2.98	1,450	2.57	1,562	2.12	1,719
3.38	1,362	<b>K202_0115</b>	<b>MR200/180</b>	182/184/TC	<b>AW200/014</b>	11.546	814	2.98	1,450	2.57	1,562	2.12	1,719
5.89	2,390	<b>K302_0115</b>	<b>MR160/050</b>	56C	<b>AW160/012</b>	11.610	951	5.20	2,544	4.48	2,741	3.70	3,017
5.89	2,390	<b>K302_0115</b>	<b>MR160/140</b>	143/145TC	<b>AW160/012</b>	11.610	951	5.20	2,544	4.48	2,741	3.70	3,017
5.89	2,390	<b>K302_0115</b>	<b>MR200/180</b>	182/184/TC	<b>AW200/014</b>	11.610	951	5.20	2,544	4.48	2,741	3.70	3,017

\* For thermal HP capacity, see rating below.

Base Module	K1	K2	K3	K4	K5	K6	K7	K8	K9	K10
Thermal Capacity	2.95	5.36	7.38	12.34	14.75	20.12	29.50	40.23	53.64	67.05

NEMA Frame Size  
TEFC 1750 RPM

C-Frame	Motor HP
56C	1/3 - 1 1/2
143/145TC	1, 1 1/2, 2
182/184TC	3, 5
213/215TC	7 1/2, 10
254/256TC	15, 20
284/286TC	25, 30
324/326TC	40, 50
364/365TC	60, 75

### Housing Styles

**N** – Foot Mounted    **F** – Round Flange    **G** – Tapped Holes    **GD** – Torque Arm Bracket

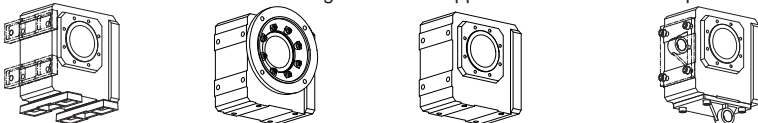

These Housing Styles are available as Hollow (A) or Solid (V) Output.



# "K" Series – Right Angle Helical/Bevel MGS Reducer – Selection Data



- NOTE:** 1) Complete Base Module Part Number by adding Output and Housing Style. Example: K302VG0560.  
 2) Select Input Option and add to completed Part Number. See example below.  
 3) Overhung Load is measured at the center of the shaft extension. Hollow output units are not intended to support overhung loads. If a load rating is required, use 50% of the published overhung load.  
 4) Other frame sizes may also be available. See dimension pages.

1750 RPM Input		Base Module <sup>1)</sup>	Input Options <sup>2)</sup>			Exact Ratio	Overhung Load Output Shaft <sup>3)</sup> lbs.	1450 RPM Input		1160 RPM Input		870 RPM Input	
Input HP	Output Torque in. lbs.		Motor Adapter	NEMA C-Frame Size <sup>4)</sup>	Input Shaft			Input HP	Output Torque in. lbs.	Input HP	Output Torque in. lbs.	Input HP	Output Torque in. lbs.
<b>150 RPM Output (Approximate) Continued</b>													
8.89	3,577	K402_0115	MR160/050	56C	AW160/012	11.518	1,518	7.84	3,808	6.52	3,959	4.89	3,959
8.89	3,577	K402_0115	MR160/140	143/145TC	AW160/012	11.518	1,518	7.84	3,808	6.52	3,959	4.89	3,959
8.89	3,577	K402_0115	MR200/180	182/184/TC	AW200/014	11.518	1,518	7.84	3,808	6.76	4,102	5.58	4,515
8.89	3,577	K402_0115	MR250/180	182/184/TC	AW250/102	11.518	1,518	7.84	3,808	6.76	4,102	5.58	4,515
16.68*	6,643	K513_0115	MR200/180	182/184/TC	AW200/014	11.569	1,825	14.72	7,072	12.68	7,618	9.95	7,972
16.68*	6,643	K513_0115	MR250/180	182/184/TC	AW250/102	11.569	1,825	14.72	7,072	12.68	7,618	9.95	7,972
22.25*	8,736	K613_0115	MR200/180	182/184/TC	AW200/014	11.407	2,163	19.37	9,177	15.49	9,177	11.62	9,177
22.25*	8,736	K613_0115	MR250/180	182/184/TC	AW250/102	11.407	2,163	19.63	9,301	16.92	10,020	13.96	11,028
22.25*	8,736	K613_0115	MR300/250	254/256TC	AW300/110	11.407	2,163	19.63	9,301	16.92	10,020	13.96	11,028
23.37	9,478	K713_0120	MR200/180	182/184/TC	AW200/014	11.781	2,998	19.37	9,478	15.49	9,478	11.62	9,478
23.37	9,578	K813_0120	MR200/180	182/184/TC	AW200/014	11.906	3,963	19.37	9,578	15.49	9,578	11.62	9,578
35.42*	14,362	K713_0120	MR250/180	182/184/TC	AW250/102	11.781	2,998	29.35	14,362	23.48	14,362	17.61	14,362
35.64*	14,452	K713_0120	MR300/250	254/256TC	AW300/110	11.781	2,998	31.44	15,387	27.10	16,575	22.37	18,243
37.08	15,196	K813_0120	MR250/210	213/215/TC	AW250/102	11.906	3,963	30.73	15,196	24.58	15,196	18.44	15,196
61.26*	25,104	K813_0120	MR300/250	254/256TC	AW300/110	11.906	3,963	54.04	26,728	46.57	28,792	35.23	29,039
<b>140 RPM Output (Approximate)</b>													
1.78	786	K102_0125	MR140/050	56C	AW140/010	12.618	693	1.57	836	1.35	901	1.10	974
1.78	786	K102_0125	MR160/050	56C	AW160/012	12.618	693	1.57	836	1.35	901	1.10	974
1.78	786	K102_0125	MR160/140	143/145TC	AW160/012	12.618	693	1.57	836	1.35	901	1.10	974
2.35	1,042	K202_0125	MR140/050	56C	AW140/010	12.705	833	1.94	1,042	1.56	1,042	1.17	1,042
2.42	1,065	K302_0125	MR140/050	56C	AW140/010	12.577	970	2.01	1,065	1.61	1,065	1.20	1,065
3.17	1,406	K202_0125	MR160/050	56C	AW160/012	12.705	833	2.79	1,497	2.41	1,613	1.98	1,772
3.17	1,406	K202_0125	MR160/140	143/145TC	AW160/012	12.705	833	2.79	1,497	2.41	1,613	1.98	1,772
3.17	1,406	K202_0125	MR200/180	182/184/TC	AW200/014	12.705	833	2.79	1,497	2.41	1,613	1.98	1,772
5.58	2,454	K302_0125	MR160/050	56C	AW160/012	12.577	970	4.93	2,613	4.25	2,815	3.50	3,098
5.58	2,454	K302_0125	MR160/140	143/145TC	AW160/012	12.577	970	4.93	2,613	4.25	2,815	3.50	3,098
5.58	2,454	K302_0125	MR200/180	182/184/TC	AW200/014	12.577	970	4.93	2,613	4.25	2,815	3.50	3,098
8.34	3,691	K402_0125	MR160/050	56C	AW160/012	12.658	1,554	7.36	3,930	6.34	4,233	4.89	4,350
8.34	3,691	K402_0125	MR160/140	143/145TC	AW160/012	12.658	1,554	7.36	3,930	6.34	4,233	4.89	4,350
8.34	3,691	K402_0125	MR200/180	182/184/TC	AW200/014	12.658	1,554	7.36	3,930	6.34	4,233	5.24	4,659
8.34	3,691	K402_0125	MR250/180	182/184/TC	AW250/102	12.658	1,554	7.36	3,930	6.34	4,233	5.24	4,659
15.59*	6,872	K513_0130	MR200/180	182/184/TC	AW200/014	12.808	1,872	13.75	7,316	11.85	7,881	8.99	7,972
15.59*	6,872	K513_0130	MR250/180	182/184/TC	AW250/102	12.808	1,872	13.75	7,316	11.85	7,881	8.99	7,972
20.79*	9,038	K613_0125	MR200/180	182/184/TC	AW200/014	12.629	2,219	18.34	9,622	15.49	10,160	11.62	10,160
20.79*	9,038	K613_0125	MR250/180	182/184/TC	AW250/102	12.629	2,219	18.34	9,622	15.81	10,365	13.05	11,409
20.79*	9,038	K613_0125	MR300/250	254/256TC	AW300/110	12.629	2,219	18.34	9,622	15.81	10,365	13.05	11,409
74.69*	32,196	K913_0125	MR300/250	254/256TC	AW300/110	12.525	8,996	61.88	32,196	49.51	32,196	37.13	32,196
107.50*	46,343	K913_0125	MR350/360	364/365TC	AW350/202	12.525	8,996	94.84	49,341	81.55	53,032	61.16	53,032
123.02*	52,846	K1013_0125	MR350/360	364/365TC	AW350/202	12.481	11,062	101.93	52,846	81.55	52,846	61.16	52,846

### Part No. Explanation

**K 4 0 2 V G 0690 AW 160 /012**

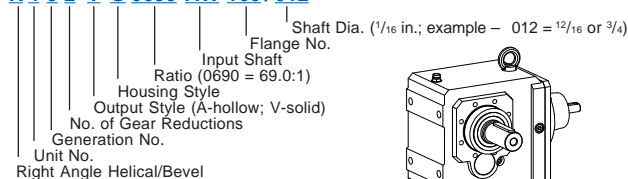

**K 4 0 2 V G 0690 MR 160 /140**

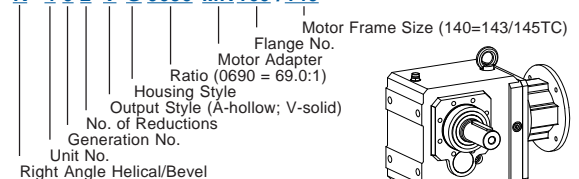

**Mounting position must be specified when ordering.**



# "K" Series – Right Angle Helical/Bevel MGS Reducer – Selection Data



### Selection Procedure:

- Under the Input RPM heading, find **Approximate Output RPM** nearest the requirement.
- In the **Input HP** column locate the rating that is greater than or equal to the required HP.  
(If selection is based on Torque instead of HP, find an **Output Torque** that is equal to or greater than required.)
- When HP or Torque rating is located, read across that row to select the **Base Module**, **Input Option** and **Overhung Loads**.
- If exact **Output RPM** is required, divide the **Input RPM** by the **Exact Ratio**.

1750 RPM Input		Base Module <sup>1)</sup>	Input Options <sup>2)</sup>			Exact Ratio	Overhung Load Output Shaft <sup>3)</sup> lbs.	1450 RPM Input		1160 RPM Input		870 RPM Input	
Input HP	Output Torque in. lbs.		Motor Adapter	NEMA C-Frame Size <sup>4)</sup>	Input Shaft			Input HP	Output Torque in. lbs.	Input HP	Output Torque in. lbs.	Input HP	Output Torque in. lbs.
<b>135 RPM Output (Approximate)</b>													
								<b>110 RPM</b>	<b>90 RPM</b>	<b>65 RPM</b>			
23.37	10,605	<b>K813_0130</b>	<b>MR200/180</b>	182/184/TC	<b>AW200/014</b>	13.182	4,065	19.37	10,605	15.49	10,605	11.62	10,605
23.37	10,493	<b>K713_0130</b>	<b>MR200/180</b>	182/184/TC	<b>AW200/014</b>	13.043	3,076	19.37	10,493	15.49	10,493	11.62	10,493
33.30*	14,951	<b>K713_0130</b>	<b>MR250/180</b>	182/184/TC	<b>AW250/102</b>	13.043	3,076	29.35	15,901	23.48	15,901	17.61	15,901
33.30*	14,951	<b>K713_0130</b>	<b>MR300/180</b>	182/184/TC	<b>AW300/110</b>	13.043	3,076	29.38	15,918	25.32	17,147	20.90	18,873
37.08	16,825	<b>K813_0130</b>	<b>MR250/180</b>	182/184/TC	<b>AW250/102</b>	13.182	4,065	30.73	16,825	24.58	16,825	18.44	16,825
57.24*	25,971	<b>K813_0130</b>	<b>MR300/250</b>	254/256TC	<b>AW300/110</b>	13.182	4,065	50.50	27,651	43.52	29,786	35.23	32,151
<b>125 RPM Output (Approximate)</b>													
								<b>100 RPM</b>	<b>85 RPM</b>	<b>62 RPM</b>			
1.65	816	<b>K102_0140</b>	<b>MR140/050</b>	56C	<b>AW140/010</b>	14.114	713	1.46	868	1.26	935	1.04	1,029
1.65	816	<b>K102_0140</b>	<b>MR160/050</b>	56C	<b>AW160/012</b>	14.114	713	1.46	868	1.26	935	1.04	1,029
1.65	816	<b>K102_0140</b>	<b>MR160/140</b>	143/145TC	<b>AW160/012</b>	14.114	713	1.46	868	1.26	935	1.04	1,029
2.44	1,181	<b>K202_0140</b>	<b>MR140/050</b>	56C	<b>AW140/010</b>	13.851	852	2.02	1,181	1.62	1,181	1.21	1,181
2.99	1,447	<b>K202_0140</b>	<b>MR160/050</b>	56C	<b>AW160/012</b>	13.851	852	2.64	1,541	2.27	1,660	1.82	1,772
2.99	1,447	<b>K202_0140</b>	<b>MR160/140</b>	143/145TC	<b>AW160/012</b>	13.851	852	2.64	1,541	2.27	1,660	1.82	1,772
5.22	2,540	<b>K302_0140</b>	<b>MR160/050</b>	56C	<b>AW160/012</b>	13.935	995	4.60	2,704	3.97	2,913	3.17	3,100
5.22	2,540	<b>K302_0140</b>	<b>MR160/140</b>	143/145TC	<b>AW160/012</b>	13.935	995	4.60	2,704	3.97	2,913	3.17	3,100
5.22	2,540	<b>K302_0140</b>	<b>MR200/180</b>	182/184/TC	<b>AW200/014</b>	13.935	995	4.60	2,704	3.97	2,913	3.17	3,100
7.85	3,806	<b>K402_0140</b>	<b>MR160/050</b>	56C	<b>AW160/012</b>	13.885	1,591	6.92	4,053	5.96	4,366	4.89	4,772
7.85	3,806	<b>K402_0140</b>	<b>MR160/140</b>	143/145TC	<b>AW160/012</b>	13.885	1,591	6.92	4,053	5.96	4,366	4.89	4,772
7.85	3,806	<b>K402_0140</b>	<b>MR200/180</b>	182/184/TC	<b>AW200/014</b>	13.885	1,591	6.92	4,053	5.96	4,366	4.92	4,805
7.85	3,806	<b>K402_0140</b>	<b>MR250/180</b>	182/184/TC	<b>AW250/102</b>	13.885	1,591	6.92	4,053	5.96	4,366	4.92	4,805
<b>120 RPM Output (Approximate)</b>													
								<b>95 RPM</b>	<b>80 RPM</b>	<b>60 RPM</b>			
9.84	4,924	<b>K513_0145</b>	<b>MR160/050</b>	56C	<b>AW160/012</b>	14.536	1,932	8.15	4,924	6.52	4,924	4.89	4,924
9.84	4,924	<b>K513_0145</b>	<b>MR160/140</b>	143/145TC	<b>AW160/012</b>	14.536	1,932	8.15	4,924	6.52	4,924	4.89	4,924
14.33	7,168	<b>K513_0145</b>	<b>MR200/180</b>	182/184/TC	<b>AW200/014</b>	14.536	1,932	12.64	7,631	10.56	7,972	7.92	7,972
14.33	7,168	<b>K513_0145</b>	<b>MR250/210</b>	213/215/TC	<b>AW250/102</b>	14.536	1,932	12.64	7,631	10.56	7,972	7.92	7,972
19.11	9,427	<b>K613_0145</b>	<b>MR200/180</b>	182/184/TC	<b>AW200/014</b>	14.332	2,290	16.86	10,037	14.53	10,812	11.62	11,530
19.11	9,427	<b>K613_0145</b>	<b>MR250/210</b>	213/215/TC	<b>AW250/102</b>	14.332	2,290	16.86	10,037	14.53	10,812	11.99	11,900
19.11	9,427	<b>K613_0145</b>	<b>MR300/250</b>	254/256TC	<b>AW300/110</b>	14.332	2,290	16.86	10,037	14.53	10,812	11.99	11,900
23.37	11,908	<b>K713_0150</b>	<b>MR200/180</b>	182/184/TC	<b>AW200/014</b>	14.802	3,175	19.37	11,908	15.49	11,908	11.62	11,908
23.37	11,940	<b>K813_0150</b>	<b>MR200/180</b>	182/184/TC	<b>AW200/014</b>	14.842	4,187	19.37	11,940	15.49	11,940	11.62	11,940
30.61*	15,595	<b>K713_0150</b>	<b>MR250/180</b>	182/184/TC	<b>AW250/102</b>	14.802	3,175	27.00	16,604	22.69	17,438	17.02	17,438
30.61*	15,595	<b>K713_0150</b>	<b>MR300/180</b>	182/184/TC	<b>AW300/110</b>	14.802	3,175	27.00	16,604	23.27	17,886	19.21	19,686
35.74	18,259	<b>K813_0150</b>	<b>MR250/210</b>	213/215/TC	<b>AW250/102</b>	14.842	4,187	29.62	18,259	23.69	18,259	17.77	18,259
52.89*	27,018	<b>K813_0150</b>	<b>MR300/280</b>	284/286TC	<b>AW300/110</b>	14.842	4,187	46.66	28,766	40.21	30,987	33.19	34,106

\* For thermal HP capacity, see rating below.

Base Module	K1	K2	K3	K4	K5	K6	K7	K8	K9	K10
Thermal Capacity	2.95	5.36	7.38	12.34	14.75	20.12	29.50	40.23	53.64	67.05

NEMA Frame Size  
TEFC 1750 RPM

C-Frame	Motor HP
56C	1/3 - 1 1/2
143/145TC	1, 1 1/2, 2
182/184TC	3, 5
213/215TC	7 1/2, 10
254/256TC	15, 20
284/286TC	25, 30
324/326TC	40, 50
364/365TC	60, 75

### Housing Styles

**N** – Foot Mounted    **F** – Round Flange    **G** – Tapped Holes    **GD** – Torque Arm Bracket

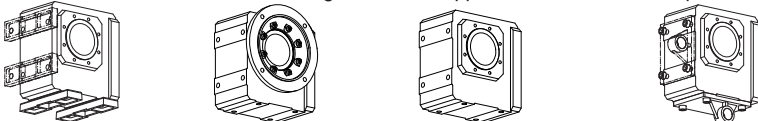

These Housing Styles are available as Hollow (A) or Solid (V) Output.





# "K" Series – Right Angle Helical/Bevel MGS Reducer – Selection Data



- NOTE:** 1) Complete Base Module Part Number by adding Output and Housing Style. Example: K302VG0560.  
 2) Select Input Option and add to completed Part Number. See example below.  
 3) Overhung Load is measured at the center of the shaft extension. Hollow output units are not intended to support overhung loads. If a load rating is required, use 50% of the published overhung load.  
 4) Other frame sizes may also be available. See dimension pages.

1750 RPM Input		Base Module <sup>1)</sup>	Input Options <sup>2)</sup>			Exact Ratio	Overhung Load Output Shaft <sup>3)</sup> lbs.	1450 RPM Input		1160 RPM Input		870 RPM Input	
Input HP	Output Torque in. lbs.		Motor Adapter	NEMA C-Frame Size <sup>4)</sup>	Input Shaft			Input HP	Output Torque in. lbs.	Input HP	Output Torque in. lbs.	Input HP	Output Torque in. lbs.
<b>110 RPM Output (Approximate)</b>													
9.84	5,451	<b>K513_0160</b>	<b>MR160/140</b>	143/145TC	<b>AW160/012</b>	16.093	1,982	8.15	5,451	6.52	5,451	4.89	5,451
9.84	5,451	<b>K513_0160</b>	<b>MR160/140</b>	143/145TC	<b>AW160/012</b>	16.093	1,982	8.15	5,451	6.52	5,451	4.89	5,451
13.39	7,415	<b>K513_0160</b>	<b>MR200/180</b>	182/184TC	<b>AW200/014</b>	16.093	1,982	11.81	7,895	9.54	7,972	7.16	7,972
13.39	7,415	<b>K513_0160</b>	<b>MR250/180</b>	182/184TC	<b>AW250/102</b>	16.093	1,982	11.81	7,895	9.54	7,972	7.16	7,972
17.86	9,752	<b>K613_0160</b>	<b>MR200/180</b>	182/184TC	<b>AW200/014</b>	15.868	2,349	15.75	10,383	13.58	11,185	11.21	12,311
17.86	9,752	<b>K613_0160</b>	<b>MR250/180</b>	182/184TC	<b>AW250/102</b>	15.868	2,349	15.75	10,383	13.58	11,185	11.21	12,311
17.86	9,752	<b>K613_0160</b>	<b>MR300/180</b>	182/184TC	<b>AW300/110</b>	15.868	2,349	15.75	10,383	13.58	11,185	11.21	12,311
71.79*	39,311	<b>K913_0160</b>	<b>MR300/250</b>	254/256TC	<b>AW300/110</b>	15.910	9,550	59.48	39,311	47.59	39,311	35.69	39,311
91.66*	50,190	<b>K913_0160</b>	<b>MR350/320</b>	324/326TC	<b>AW350/202</b>	15.910	9,550	80.86	53,437	69.68	57,563	56.29	62,006
123.02*	67,221	<b>K1013_0160</b>	<b>MR350/360</b>	364/365TC	<b>AW350/202</b>	15.876	11,748	101.93	67,221	81.55	67,221	61.16	67,221
<b>105 RPM Output (Approximate)</b>													
1.48	863	<b>K102_0165</b>	<b>MR140/050</b>	56C	<b>AW140/010</b>	16.714	744	1.30	919	1.11	974	0.83	974
1.48	863	<b>K102_0165</b>	<b>MR160/050</b>	56C	<b>AW160/012</b>	16.714	744	1.30	919	1.11	974	0.83	974
1.48	863	<b>K102_0165</b>	<b>MR160/140</b>	143/145TC	<b>AW160/012</b>	16.714	744	1.30	919	1.11	974	0.83	974
2.23	1,313	<b>K202_0170</b>	<b>MR140/050</b>	56C	<b>AW140/010</b>	16.858	894	1.85	1,313	1.48	1,313	1.11	1,313
2.29	1,358	<b>K302_0170</b>	<b>MR140/050</b>	56C	<b>AW140/010</b>	16.939	1,045	1.90	1,358	1.52	1,358	1.14	1,358
2.62	1,545	<b>K202_0170</b>	<b>MR160/050</b>	56C	<b>AW160/012</b>	16.858	894	2.31	1,645	1.99	1,772	1.50	1,772
2.62	1,545	<b>K202_0170</b>	<b>MR160/140</b>	143/145TC	<b>AW160/012</b>	16.858	894	2.31	1,645	1.99	1,772	1.50	1,772
4.58	2,710	<b>K302_0170</b>	<b>MR160/050</b>	56C	<b>AW160/012</b>	16.939	1,045	4.04	2,886	3.47	3,100	2.60	3,100
4.58	2,710	<b>K302_0170</b>	<b>MR160/140</b>	143/145TC	<b>AW160/012</b>	16.939	1,045	4.04	2,886	3.47	3,100	2.60	3,100
4.58	2,710	<b>K302_0170</b>	<b>MR200/180</b>	182/184TC	<b>AW200/014</b>	16.939	1,045	4.04	2,886	3.47	3,100	2.60	3,100
6.87	4,067	<b>K402_0170</b>	<b>MR160/050</b>	56C	<b>AW160/012</b>	16.939	1,672	6.06	4,330	5.22	4,665	4.09	4,872
6.87	4,067	<b>K402_0170</b>	<b>MR160/140</b>	143/145TC	<b>AW160/012</b>	16.939	1,672	6.06	4,330	5.22	4,665	4.09	4,872
6.87	4,067	<b>K402_0170</b>	<b>MR200/180</b>	182/184TC	<b>AW200/014</b>	16.939	1,672	6.06	4,330	5.22	4,665	4.09	4,872
6.87	4,067	<b>K402_0170</b>	<b>MR250/210</b>	213/215TC	<b>AW250/102</b>	16.939	1,672	6.06	4,330	5.22	4,665	4.09	4,872
9.84	5,811	<b>K613_0170</b>	<b>MR160/050</b>	56C	<b>AW160/012</b>	17.156	2,396	8.15	5,811	6.52	5,811	4.89	5,811
9.84	5,811	<b>K613_0170</b>	<b>MR160/140</b>	143/145TC	<b>AW160/012</b>	17.156	2,396	8.15	5,811	6.52	5,811	4.89	5,811
16.95	10,009	<b>K613_0170</b>	<b>MR200/180</b>	182/184TC	<b>AW200/014</b>	17.156	2,396	14.95	10,657	12.89	11,480	10.64	12,635
16.95	10,009	<b>K613_0170</b>	<b>MR250/180</b>	182/184TC	<b>AW250/102</b>	17.156	2,396	14.95	10,657	12.89	11,480	10.64	12,635
16.95	10,009	<b>K613_0170</b>	<b>MR300/280</b>	284/286TC	<b>AW300/110</b>	17.156	2,396	14.95	10,657	12.89	11,480	10.64	12,635
23.37	13,184	<b>K713_0165</b>	<b>MR200/180</b>	182/184TC	<b>AW200/014</b>	16.388	3,256	19.37	13,184	15.49	13,184	11.62	13,184
23.37	13,219	<b>K813_0165</b>	<b>MR200/180</b>	182/184TC	<b>AW200/014</b>	16.432	4,295	19.37	13,219	15.49	13,219	11.62	13,219
28.60	16,133	<b>K713_0165</b>	<b>MR250/180</b>	182/184TC	<b>AW250/102</b>	16.388	3,256	25.23	17,177	21.74	18,503	17.02	19,306
28.60	16,133	<b>K713_0165</b>	<b>MR300/250</b>	254/256TC	<b>AW300/110</b>	16.388	3,256	25.23	17,177	21.74	18,503	17.95	20,365
35.74	20,215	<b>K813_0165</b>	<b>MR250/210</b>	213/215TC	<b>AW250/102</b>	16.432	4,295	29.62	20,215	23.69	20,215	17.77	20,215
49.42*	27,951	<b>K813_0165</b>	<b>MR300/180</b>	182/184TC	<b>AW300/110</b>	16.432	4,295	43.60	29,759	37.57	32,057	31.01	35,283

### Part No. Explanation

**K 4 0 2 V G 0690 AW 160 /012**

K: Right Angle Helical/Bevel  
 4: Unit No.  
 0: Generation No.  
 2: No. of Gear Reductions  
 V: Output Style (A-hollow; V-solid)  
 G: Housing Style  
 0690: Ratio (0690 = 69.0:1)  
 AW: Input Shaft  
 160: Flange No.  
 012: Shaft Dia. (1/16 in.; example - 012 = 12/16 or 3/4)

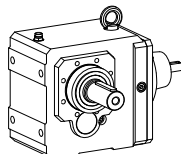

**K 4 0 2 V G 0690 MR 160 /140**

K: Right Angle Helical/Bevel  
 4: Unit No.  
 0: Generation No.  
 2: No. of Reductions  
 V: Output Style (A-hollow; V-solid)  
 G: Housing Style  
 0690: Ratio (0690 = 69.0:1)  
 MR: Motor Adapter  
 160: Flange No.  
 140: Motor Frame Size (140=143/145TC)

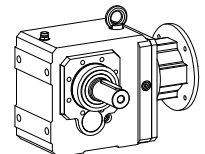

**Mounting position must be specified when ordering.**



# "K" Series – Right Angle Helical/Bevel MGS Reducer – Selection Data



### Selection Procedure:

- Under the Input RPM heading, find **Approximate Output RPM** nearest the requirement.
- In the **Input HP** column locate the rating that is greater than or equal to the required HP.  
(If selection is based on Torque instead of HP, find an **Output Torque** that is equal to or greater than required.)
- When HP or Torque rating is located, read across that row to select the **Base Module**, **Input Option** and **Overhung Loads**.
- If exact **Output RPM** is required, divide the **Input RPM** by the **Exact Ratio**.

1750 RPM Input		Base Module <sup>1)</sup>	Input Options <sup>2)</sup>			Exact Ratio	Overhung Load Output Shaft <sup>3)</sup> lbs.	1450 RPM Input		1160 RPM Input		870 RPM Input	
Input HP	Output Torque in. lbs.		Motor Adapter	NEMA C-Frame Size <sup>4)</sup>	Input Shaft			Input HP	Output Torque in. lbs.	Input HP	Output Torque in. lbs.	Input HP	Output Torque in. lbs.

100 RPM Output (Approximate)							82 RPM		65 RPM		50 RPM		
1.43	877	K102_0175	MR140/050	56C	AW140/010	17.563	753	1.26	934	1.09	1,006	0.86	1,063
1.43	877	K102_0175	MR160/050	56C	AW160/012	17.563	753	1.26	934	1.09	1,006	0.86	1,063
1.43	877	K102_0175	MR160/140	143/145TC	AW160/012	17.563	753	1.26	934	1.09	1,006	0.86	1,063
2.35	1,433	K202_0175	MR140/050	56C	AW140/010	17.469	902	1.94	1,433	1.56	1,433	1.17	1,433
2.42	1,464	K302_0175	MR140/050	56C	AW140/010	17.293	1,050	2.01	1,464	1.61	1,464	1.20	1,464
2.56	1,564	K202_0175	MR160/050	56C	AW160/012	17.469	902	2.26	1,665	1.92	1,772	1.44	1,772
2.56	1,564	K202_0175	MR160/140	143/145TC	AW160/012	17.469	902	2.26	1,665	1.92	1,772	1.44	1,772
4.52	2,729	K302_0175	MR160/050	56C	AW160/012	17.293	1,050	3.98	2,906	3.40	3,100	2.55	3,100
4.52	2,729	K302_0175	MR160/140	143/145TC	AW160/012	17.293	1,050	3.98	2,906	3.40	3,100	2.55	3,100
4.52	2,729	K302_0175	MR200/180	182/184/TC	AW200/014	17.293	1,050	3.98	2,906	3.40	3,100	2.55	3,100
6.75	4,104	K402_0175	MR160/050	56C	AW160/012	17.405	1,683	5.95	4,370	5.13	4,707	3.98	4,872
6.75	4,104	K402_0175	MR160/140	143/145TC	AW160/012	17.405	1,683	5.95	4,370	5.13	4,707	3.98	4,872
6.75	4,104	K402_0175	MR200/180	182/184/TC	AW200/014	17.405	1,683	5.95	4,370	5.13	4,707	3.98	4,872
6.75	4,104	K402_0175	MR250/180	182/184/TC	AW250/102	17.405	1,683	5.95	4,370	5.13	4,707	3.98	4,872
9.84	5,921	K513_0175	MR160/050	56C	AW160/012	17.481	2,023	8.15	5,921	6.52	5,921	4.89	5,921
9.84	5,921	K513_0175	MR160/140	143/145TC	AW160/012	17.481	2,023	8.15	5,921	6.52	5,921	4.89	5,921
12.67	7,622	K513_0175	MR200/180	182/184/TC	AW200/014	17.481	2,023	10.98	7,972	8.78	7,972	6.59	7,972
12.67	7,622	K513_0175	MR250/180	182/184/TC	AW250/102	17.481	2,023	10.98	7,972	8.78	7,972	6.59	7,972
23.37	13,939	K813_0175	MR200/180	182/184/TC	AW200/014	17.327	4,353	19.37	13,939	15.49	13,939	11.62	13,939
34.86	20,791	K813_0175	MR250/180	182/184/TC	AW250/102	17.327	4,353	28.89	20,791	23.11	20,791	17.33	20,791
47.70*	28,449	K813_0175	MR300/250	254/256TC	AW300/110	17.327	4,353	42.08	30,290	36.27	32,628	29.94	35,912

95 RPM Output (Approximate)							78 RPM		63 RPM		48 RPM		
23.37	14,702	K713_0185	MR200/180	182/184/TC	AW200/014	18.275	3,346	19.37	14,702	15.49	14,702	11.62	14,702
26.60	16,730	K713_0185	MR250/180	182/184/TC	AW250/102	18.275	3,346	23.46	17,812	20.22	19,187	16.41	20,765
26.60	16,730	K713_0185	MR300/180	182/184/TC	AW300/110	18.275	3,346	23.46	17,812	20.22	19,187	16.69	21,118

90 RPM Output (Approximate) <b>Continued Next Page</b>							75 RPM		60 RPM		45 RPM		
9.84	6,434	K613_0190	MR160/050	56C	AW160/012	18.994	2,457	8.15	6,434	6.52	6,434	4.89	6,434
9.84	6,434	K613_0190	MR160/140	143/145TC	AW160/012	18.994	2,457	8.15	6,434	6.52	6,434	4.89	6,434
9.84	6,555	K513_0195	MR160/050	56C	AW160/012	19.353	2,075	8.15	6,555	6.52	6,555	4.89	6,555
9.84	6,555	K513_0195	MR160/140	143/145TC	AW160/012	19.353	2,075	8.15	6,555	6.52	6,555	4.89	6,555
11.84	7,885	K513_0195	MR200/180	182/184/TC	AW200/014	19.353	2,075	9.92	7,972	7.93	7,972	5.95	7,972
11.84	7,885	K513_0195	MR250/180	182/184/TC	AW250/102	19.353	2,075	9.92	7,972	7.93	7,972	5.95	7,972
15.84	10,355	K613_0190	MR200/180	182/184/TC	AW200/014	18.994	2,457	13.97	11,025	12.04	11,876	9.77	12,844
15.84	10,355	K613_0190	MR250/180	182/184/TC	AW250/102	18.994	2,457	13.97	11,025	12.04	11,876	9.77	12,844
15.84	10,355	K613_0190	MR300/250	254/256TC	AW300/110	18.994	2,457	13.97	11,025	12.04	11,876	9.77	12,844
23.37	15,432	K813_0190	MR200/180	182/184/TC	AW200/014	19.183	4,465	19.37	15,432	15.49	15,432	11.62	15,432
34.86	23,018	K813_0190	MR250/180	182/184/TC	AW250/102	19.183	4,465	28.89	23,018	23.11	23,018	17.33	23,018

\* For thermal HP capacity, see rating below.

Base Module	K1	K2	K3	K4	K5	K6	K7	K8	K9	K10
Thermal Capacity	2.95	5.36	7.38	12.34	14.75	20.12	29.50	40.23	53.64	67.05

NEMA Frame Size  
TEFC 1750 RPM

C-Frame	Motor HP
56C	1/3 - 1 1/2
143/145TC	1, 1 1/2, 2
182/184TC	3, 5
213/215TC	7 1/2, 10
254/256TC	15, 20
284/286TC	25, 30
324/326TC	40, 50
364/365TC	60, 75

### Housing Styles

**N** – Foot Mounted    **F** – Round Flange    **G** – Tapped Holes    **GD** – Torque Arm Bracket

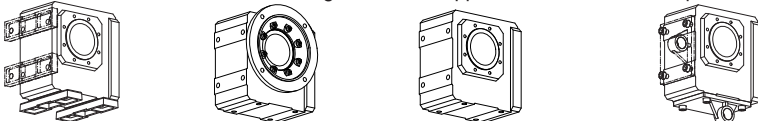

These Housing Styles are available as Hollow (A) or Solid (V) Output.





# "K" Series – Right Angle Helical/Bevel MGS Reducer – Selection Data



- NOTE:** 1) Complete Base Module Part Number by adding Output and Housing Style. Example: K302VG0560.  
 2) Select Input Option and add to completed Part Number. See example below.  
 3) Overhung Load is measured at the center of the shaft extension. Hollow output units are not intended to support overhung loads. If a load rating is required, use 50% of the published overhung load.  
 4) Other frame sizes may also be available. See dimension pages.

1750 RPM Input		Base Module <sup>1)</sup>	Input Options <sup>2)</sup>			Exact Ratio	Overhung Load Output Shaft <sup>3)</sup> lbs.	1450 RPM Input		1160 RPM Input		870 RPM Input	
Input HP	Output Torque in. lbs.		Motor Adapter	NEMA C-Frame Size <sup>4)</sup>	Input Shaft			Input HP	Output Torque in. lbs.	Input HP	Output Torque in. lbs.	Input HP	Output Torque in. lbs.
<b>90 RPM Output (Approximate) Continued</b>													
44.58*	29,431	K813_0190	MR300/210	213/215/TC	AW300/110	19.183	4,465	39.32	31,335	33.89	33,754	27.97	37,151
69.53*	45,620	K913_0190	MR300/180	182/184/TC	AW300/110	19.063	9,992	57.61	45,620	46.09	45,620	34.57	45,620
81.25*	53,308	K913_0190	MR350/320	324/326TC	AW350/202	19.063	9,992	71.68	56,756	61.77	61,139	46.98	62,006
123.02*	79,394	K1013_0190	MR350/320	324/326TC	AW350/202	18.751	12,247	101.93	79,394	81.55	79,394	61.16	79,394
<b>85 RPM Output (Approximate)</b>													
1.30	918	K102_0200	MR140/050	56C	AW140/010	20.150	779	1.15	974	0.92	974	0.69	974
1.30	918	K102_0200	MR160/050	56C	AW160/012	20.150	779	1.15	974	0.92	974	0.69	974
1.30	918	K102_0200	MR160/140	143/145TC	AW160/012	20.150	779	1.15	974	0.92	974	0.69	974
2.14	1,522	K202_0200	MR140/050	56C	AW140/010	20.327	937	1.78	1,522	1.42	1,522	1.07	1,522
2.22	1,570	K302_0200	MR140/050	56C	AW140/010	20.278	1,093	1.84	1,570	1.47	1,570	1.10	1,570
2.32	1,645	K202_0200	MR160/050	56C	AW160/012	20.327	937	2.04	1,751	1.65	1,772	1.24	1,772
2.32	1,645	K202_0200	MR160/140	143/145TC	AW160/012	20.327	937	2.04	1,751	1.65	1,772	1.24	1,772
4.06	2,878	K302_0200	MR160/050	56C	AW160/012	20.278	1,093	3.58	3,064	2.90	3,100	2.18	3,100
4.06	2,878	K302_0200	MR160/140	143/145TC	AW160/012	20.278	1,093	3.58	3,064	2.90	3,100	2.18	3,100
4.06	2,878	K302_0200	MR200/180	182/184/TC	AW200/014	20.278	1,093	3.58	3,064	2.90	3,100	2.18	3,100
6.11	4,313	K402_0200	MR160/050	56C	AW160/012	20.197	1,747	5.39	4,592	4.58	4,872	3.43	4,872
6.11	4,313	K402_0200	MR160/140	143/145TC	AW160/012	20.197	1,747	5.39	4,592	4.58	4,872	3.43	4,872
6.11	4,313	K402_0200	MR200/180	182/184/TC	AW200/014	20.197	1,747	5.39	4,592	4.58	4,872	3.43	4,872
6.11	4,313	K402_0200	MR250/210	213/215/TC	AW250/102	20.197	1,747	5.39	4,592	4.58	4,872	3.43	4,872
23.37	16,277	K713_0200	MR200/180	182/184/TC	AW200/014	20.233	3,433	19.37	16,277	15.49	16,277	11.62	16,277
24.85	17,307	K713_0200	MR250/180	182/184/TC	AW250/102	20.233	3,433	21.92	18,427	18.89	19,850	15.18	21,259
24.85	17,307	K713_0200	MR300/210	213/215/TC	AW300/110	20.233	3,433	21.92	18,427	18.89	19,850	15.18	21,259
<b>80 RPM Output (Approximate)</b>													
9.84	7,345	K613_0220	MR160/050	56C	AW160/012	21.684	2,540	8.15	7,345	6.52	7,345	4.89	7,345
9.84	7,345	K613_0220	MR160/140	143/145TC	AW160/012	21.684	2,540	8.15	7,345	6.52	7,345	4.89	7,345
9.84	7,449	K513_0220	MR160/050	56C	AW160/012	21.992	2,143	8.15	7,449	6.52	7,449	4.89	7,449
9.84	7,449	K513_0220	MR160/140	143/145TC	AW160/012	21.992	2,143	8.15	7,449	6.52	7,449	4.89	7,449
10.53	7,972	K513_0220	MR200/180	182/184/TC	AW200/014	21.992	2,143	8.73	7,972	6.98	7,972	5.24	7,972
10.53	7,972	K513_0220	MR250/210	213/215/TC	AW250/102	21.992	2,143	8.73	7,972	6.98	7,972	5.24	7,972
14.50	10,822	K613_0220	MR200/180	182/184/TC	AW200/014	21.684	2,540	12.79	11,522	11.02	12,412	8.56	12,844
14.50	10,822	K613_0220	MR250/180	182/184/TC	AW250/102	21.684	2,540	12.79	11,522	11.02	12,412	8.56	12,844
14.50	10,822	K613_0220	MR300/280	284/286TC	AW300/110	21.684	2,540	12.79	11,522	11.02	12,412	8.56	12,844
<b>75 RPM Output (Approximate) Continued Next Page</b>													
1.19	963	K102_0230	MR140/050	56C	AW140/010	23.265	808	1.05	1,026	0.87	1,063	0.65	1,063
1.19	963	K102_0230	MR160/050	56C	AW160/012	23.265	808	1.05	1,026	0.87	1,063	0.65	1,063
1.19	963	K102_0230	MR160/140	143/145TC	AW160/012	23.265	808	1.05	1,026	0.87	1,063	0.65	1,063
2.12	1,718	K202_0230	MR140/050	56C	AW140/010	23.180	969	1.81	1,772	1.45	1,772	1.09	1,772

### Part No. Explanation

**K 4 0 2 V G 0690 AW 160 /012**

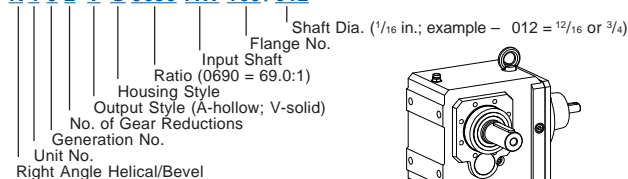

**K 4 0 2 V G 0690 MR 160 /140**

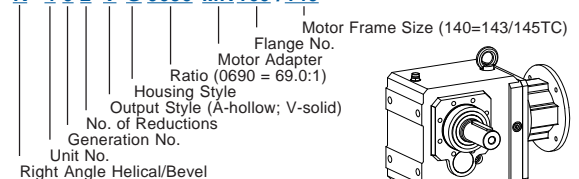

**Mounting position must be specified when ordering.**



# "K" Series – Right Angle Helical/Bevel MGS Reducer – Selection Data



### Selection Procedure:

- Under the Input RPM heading, find **Approximate Output RPM** nearest the requirement.
- In the **Input HP** column locate the rating that is greater than or equal to the required HP.  
(If selection is based on Torque instead of HP, find an **Output Torque** that is equal to or greater than required.)
- When HP or Torque rating is located, read across that row to select the **Base Module**, **Input Option** and **Overhung Loads**.
- If exact **Output RPM** is required, divide the **Input RPM** by the **Exact Ratio**.

1750 RPM Input		Base Module <sup>1)</sup>	Input Options <sup>2)</sup>			Exact Ratio	Overhung Load Output Shaft <sup>3)</sup> lbs.	1450 RPM Input		1160 RPM Input		870 RPM Input	
Input HP	Output Torque in. lbs.		Motor Adapter	NEMA C-Frame Size <sup>4)</sup>	Input Shaft			Input HP	Output Torque in. lbs.	Input HP	Output Torque in. lbs.	Input HP	Output Torque in. lbs.
<b>75 RPM Output (Approximate) Continued</b>													
								<b>60 RPM</b>		<b>50 RPM</b>		<b>38 RPM</b>	
2.12	1,718	<b>K202_0230</b>	<b>MR160/050</b>	56C	<b>AW160/012</b>	23.180	969	1.81	1,772	1.45	1,772	1.09	1,772
2.12	1,718	<b>K202_0230</b>	<b>MR160/140</b>	143/145TC	<b>AW160/012</b>	23.180	969	1.81	1,772	1.45	1,772	1.09	1,772
2.29	1,867	<b>K302_0230</b>	<b>MR140/050</b>	56C	<b>AW140/010</b>	23.292	1,131	1.90	1,867	1.52	1,867	1.14	1,867
3.70	3,014	<b>K302_0230</b>	<b>MR160/050</b>	56C	<b>AW160/012</b>	23.292	1,131	3.16	3,100	2.53	3,100	1.89	3,100
3.70	3,014	<b>K302_0230</b>	<b>MR160/140</b>	143/145TC	<b>AW160/012</b>	23.292	1,131	3.16	3,100	2.53	3,100	1.89	3,100
3.70	3,014	<b>K302_0230</b>	<b>MR200/180</b>	182/184/TC	<b>AW200/014</b>	23.292	1,131	3.16	3,100	2.53	3,100	1.89	3,100
5.56	4,523	<b>K402_0230</b>	<b>MR160/050</b>	56C	<b>AW160/012</b>	23.292	1,810	4.90	4,815	3.97	4,872	2.98	4,872
5.56	4,523	<b>K402_0230</b>	<b>MR160/140</b>	143/145TC	<b>AW160/012</b>	23.292	1,810	4.90	4,815	3.97	4,872	2.98	4,872
5.56	4,523	<b>K402_0230</b>	<b>MR200/180</b>	182/184/TC	<b>AW200/014</b>	23.292	1,810	4.90	4,815	3.97	4,872	2.98	4,872
5.56	4,523	<b>K402_0230</b>	<b>MR250/180</b>	182/184/TC	<b>AW250/102</b>	23.292	1,810	4.90	4,815	3.97	4,872	2.98	4,872
9.51	7,972	<b>K513_0240</b>	<b>MR160/050</b>	56C	<b>AW160/012</b>	24.348	2,198	7.88	7,972	6.31	7,972	4.73	7,972
9.51	7,972	<b>K513_0240</b>	<b>MR160/140</b>	143/145TC	<b>AW160/012</b>	24.348	2,198	7.88	7,972	6.31	7,972	4.73	7,972
9.51	7,972	<b>K513_0240</b>	<b>MR200/180</b>	182/184/TC	<b>AW200/014</b>	24.348	2,198	7.88	7,972	6.31	7,972	4.73	7,972
9.51	7,972	<b>K513_0240</b>	<b>MR250/180</b>	182/184/TC	<b>AW250/102</b>	24.348	2,198	7.88	7,972	6.31	7,972	4.73	7,972
9.84	8,132	<b>K613_0240</b>	<b>MR160/050</b>	56C	<b>AW160/012</b>	24.007	2,605	8.15	8,132	6.52	8,132	4.89	8,132
9.84	8,132	<b>K613_0240</b>	<b>MR160/140</b>	143/145TC	<b>AW160/012</b>	24.007	2,605	8.15	8,132	6.52	8,132	4.89	8,132
13.55	11,196	<b>K613_0240</b>	<b>MR200/180</b>	182/184/TC	<b>AW200/014</b>	24.007	2,605	11.95	11,920	10.30	12,840	7.73	12,844
13.55	11,196	<b>K613_0240</b>	<b>MR250/180</b>	182/184/TC	<b>AW250/102</b>	24.007	2,605	11.95	11,920	10.30	12,840	7.73	12,844
13.55	11,196	<b>K613_0240</b>	<b>MR300/250</b>	254/256TC	<b>AW300/110</b>	24.007	2,605	11.95	11,920	10.30	12,840	7.73	12,844
22.21	17,383	<b>K713_0230</b>	<b>MR200/180</b>	182/184/TC	<b>AW200/014</b>	22.739	3,534	19.37	18,293	15.49	18,293	11.62	18,293
22.99	17,994	<b>K713_0230</b>	<b>MR250/210</b>	213/215/TC	<b>AW250/102</b>	22.739	3,534	20.28	19,158	17.48	20,637	13.50	21,259
22.99	17,994	<b>K713_0230</b>	<b>MR300/180</b>	182/184/TC	<b>AW300/110</b>	22.739	3,534	20.28	19,158	17.48	20,637	13.50	21,259
23.37	18,539	<b>K813_0230</b>	<b>MR200/180</b>	182/184/TC	<b>AW200/014</b>	23.044	4,674	19.37	18,539	15.49	18,539	11.62	18,539
33.01	26,184	<b>K813_0230</b>	<b>MR250/180</b>	182/184/TC	<b>AW250/102</b>	23.044	4,674	27.35	26,184	21.88	26,184	16.41	26,184
34.86	28,729	<b>K913_0240</b>	<b>MR250/180</b>	182/184/TC	<b>AW250/102</b>	23.943	10,578	28.89	28,729	23.11	28,729	17.33	28,729
39.45	31,286	<b>K813_0230</b>	<b>MR300/180</b>	182/184/TC	<b>AW300/110</b>	23.044	4,674	34.80	33,310	29.99	35,882	23.32	37,204
66.62*	54,898	<b>K913_0240</b>	<b>MR300/180</b>	182/184/TC	<b>AW300/110</b>	23.943	10,578	55.20	54,898	44.16	54,898	33.12	54,898
69.79*	57,516	<b>K913_0240</b>	<b>MR350/320</b>	324/326TC	<b>AW350/202</b>	23.943	10,578	61.57	61,236	49.88	62,006	37.41	62,006
123.02*	100,743	<b>K1013_0240</b>	<b>MR350/320</b>	324/326TC	<b>AW350/202</b>	23.793	12,998	101.93	100,743	81.55	100,743	61.16	100,743

<b>70 RPM Output (Approximate) Continued Next Page</b>													
								<b>55 RPM</b>		<b>45 RPM</b>		<b>35 RPM</b>	
0.97	851	<b>K102_0250</b>	<b>MR140/050</b>	56C	<b>AW140/010</b>	25.220	824	0.80	851	0.64	851	0.48	851
0.97	851	<b>K102_0250</b>	<b>MR160/050</b>	56C	<b>AW160/012</b>	25.220	824	0.80	851	0.64	851	0.48	851
2.01	1,765	<b>K202_0250</b>	<b>MR140/050</b>	56C	<b>AW140/010</b>	25.130	988	1.67	1,772	1.34	1,772	1.00	1,772
2.01	1,765	<b>K202_0250</b>	<b>MR160/050</b>	56C	<b>AW160/012</b>	25.130	988	1.67	1,772	1.34	1,772	1.00	1,772
2.01	1,765	<b>K202_0250</b>	<b>MR160/140</b>	143/145TC	<b>AW160/012</b>	25.130	988	1.67	1,772	1.34	1,772	1.00	1,772
2.13	1,877	<b>K302_0250</b>	<b>MR140/050</b>	56C	<b>AW140/010</b>	25.259	1,154	1.76	1,877	1.41	1,877	1.06	1,877
3.48	3,070	<b>K302_0250</b>	<b>MR160/050</b>	56C	<b>AW160/012</b>	25.259	1,154	2.88	3,070	2.31	3,070	1.73	3,070
3.48	3,070	<b>K302_0250</b>	<b>MR160/140</b>	143/145TC	<b>AW160/012</b>	25.259	1,154	2.88	3,070	2.31	3,070	1.73	3,070
3.48	3,070	<b>K302_0250</b>	<b>MR200/180</b>	182/184/TC	<b>AW200/014</b>	25.259	1,154	2.88	3,070	2.31	3,070	1.73	3,070

\* For thermal HP capacity, see rating below.

Base Module	K1	K2	K3	K4	K5	K6	K7	K8	K9	K10
Thermal Capacity	2.95	5.36	7.38	12.34	14.75	20.12	29.50	40.23	53.64	67.05

NEMA Frame Size  
TEFC 1750 RPM

C-Frame	Motor HP
56C	1/3 - 1 1/2
143/145TC	1, 1 1/2, 2
182/184TC	3, 5
213/215TC	7 1/2, 10
254/256TC	15, 20
284/286TC	25, 30
324/326TC	40, 50
364/365TC	60, 75

### Housing Styles

**N** – Foot Mounted    **F** – Round Flange    **G** – Tapped Holes    **GD** – Torque Arm Bracket

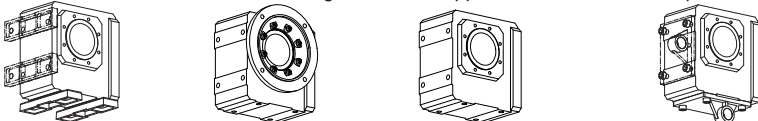

These Housing Styles are available as Hollow (A) or Solid (V) Output.



# "K" Series – Right Angle Helical/Bevel MGS Reducer – Selection Data



- NOTE:** 1) Complete Base Module Part Number by adding Output and Housing Style. Example: K302VG0560.  
 2) Select Input Option and add to completed Part Number. See example below.  
 3) Overhung Load is measured at the center of the shaft extension. Hollow output units are not intended to support overhung loads. If a load rating is required, use 50% of the published overhung load.  
 4) Other frame sizes may also be available. See dimension pages.

1750 RPM Input		Base Module <sup>1)</sup>	Input Options <sup>2)</sup>			Exact Ratio	Overhung Load Output Shaft <sup>3)</sup> lbs.	1450 RPM Input		1160 RPM Input		870 RPM Input	
Input HP	Output Torque in. lbs.		Motor Adapter	NEMA C-Frame Size <sup>4)</sup>	Input Shaft			Input HP	Output Torque in. lbs.	Input HP	Output Torque in. lbs.	Input HP	Output Torque in. lbs.
<b>70 RPM Output (Approximate) Continued</b>													
5.02	4,434	K402_0250	MR160/050	56C	AW160/012	25.279	1,848	4.16	4,434	3.33	4,434	2.50	4,434
5.02	4,434	K402_0250	MR160/140	143/145TC	AW160/012	25.279	1,848	4.16	4,434	3.33	4,434	2.50	4,434
5.02	4,434	K402_0250	MR200/180	182/184/TC	AW200/014	25.279	1,848	4.16	4,434	3.33	4,434	2.50	4,434
5.02	4,434	K402_0250	MR250/180	182/184/TC	AW250/102	25.279	1,848	4.16	4,434	3.33	4,434	2.50	4,434
21.48	18,615	K713_0250	MR200/180	182/184/TC	AW200/014	25.175	3,625	18.95	19,819	15.49	20,253	11.62	20,253
21.48	18,615	K713_0250	MR250/180	182/184/TC	AW250/102	25.175	3,625	18.95	19,819	16.26	21,259	12.20	21,259
21.48	18,615	K713_0250	MR300/180	182/184/TC	AW300/110	25.175	3,625	18.95	19,819	16.26	21,259	12.20	21,259
23.37	20,525	K813_0260	MR200/180	182/184/TC	AW200/014	25.513	4,795	19.37	20,525	15.49	20,525	11.62	20,525
33.01	28,989	K813_0260	MR250/180	182/184/TC	AW250/102	25.513	4,795	27.35	28,989	21.88	28,989	16.41	28,989
36.86	32,365	K813_0260	MR300/210	213/215/TC	AW300/110	25.513	4,795	32.52	34,459	28.02	37,120	21.06	37,204
<b>60 RPM Output (Approximate)</b>													
1.05	1,025	K102_0280	MR140/050	56C	AW140/010	28.048	846	0.90	1,063	0.72	1,063	0.54	1,063
1.05	1,025	K102_0280	MR160/050	56C	AW160/012	28.048	846	0.90	1,063	0.72	1,063	0.54	1,063
1.05	1,025	K102_0280	MR160/140	143/145TC	AW160/012	28.048	846	0.90	1,063	0.72	1,063	0.54	1,063
1.81	1,772	K202_0280	MR140/050	56C	AW140/010	27.950	1,015	1.50	1,772	1.20	1,772	0.90	1,772
1.81	1,772	K202_0280	MR160/050	56C	AW160/012	27.950	1,015	1.50	1,772	1.20	1,772	0.90	1,772
1.81	1,772	K202_0280	MR160/140	143/145TC	AW160/012	27.950	1,015	1.50	1,772	1.20	1,772	0.90	1,772
2.22	2,159	K302_0280	MR140/050	56C	AW140/010	27.883	1,183	1.84	2,159	1.47	2,159	1.10	2,159
3.18	3,100	K302_0280	MR160/050	56C	AW160/012	27.883	1,183	2.64	3,100	2.11	3,100	1.58	3,100
3.18	3,100	K302_0280	MR160/140	143/145TC	AW160/012	27.883	1,183	2.64	3,100	2.11	3,100	1.58	3,100
3.18	3,100	K302_0280	MR200/180	182/184/TC	AW200/014	27.883	1,183	2.64	3,100	2.11	3,100	1.58	3,100
4.94	4,796	K402_0280	MR160/050	56C	AW160/012	27.771	1,891	4.16	4,872	3.33	4,872	2.50	4,872
4.94	4,796	K402_0280	MR160/140	143/145TC	AW160/012	27.771	1,891	4.16	4,872	3.33	4,872	2.50	4,872
4.94	4,796	K402_0280	MR200/180	182/184/TC	AW200/014	27.771	1,891	4.16	4,872	3.33	4,872	2.50	4,872
4.94	4,796	K402_0280	MR250/180	182/184/TC	AW250/102	27.771	1,891	4.16	4,872	3.33	4,872	2.50	4,872
7.94	7,972	K513_0290	MR160/050	56C	AW160/012	29.181	2,300	6.58	7,972	5.26	7,972	3.95	7,972
7.94	7,972	K513_0290	MR160/140	143/145TC	AW160/012	29.181	2,300	6.58	7,972	5.26	7,972	3.95	7,972
7.94	7,972	K513_0290	MR200/180	182/184/TC	AW200/014	29.181	2,300	6.58	7,972	5.26	7,972	3.95	7,972
7.94	7,972	K513_0290	MR250/180	182/184/TC	AW250/102	29.181	2,300	6.58	7,972	5.26	7,972	3.95	7,972
9.70	9,606	K613_0290	MR160/050	56C	AW160/012	28.772	2,726	8.15	9,746	6.52	9,746	4.89	9,746
9.70	9,606	K613_0290	MR160/140	143/145TC	AW160/012	28.772	2,726	8.15	9,746	6.52	9,746	4.89	9,746
12.01	11,892	K613_0290	MR200/180	182/184/TC	AW200/014	28.772	2,726	10.59	12,661	8.60	12,844	6.45	12,844
12.01	11,892	K613_0290	MR250/180	182/184/TC	AW250/102	28.772	2,726	10.59	12,661	8.60	12,844	6.45	12,844
12.01	11,892	K613_0290	MR300/210	213/215/TC	AW300/110	28.772	2,726	10.59	12,661	8.60	12,844	6.45	12,844
18.58	18,728	K713_0290	MR200/180	182/184/TC	AW200/014	29.285	3,765	16.39	19,939	13.98	21,259	10.49	21,259
19.42	19,577	K713_0290	MR250/180	182/184/TC	AW250/102	29.285	3,765	17.13	20,844	13.98	21,259	10.49	21,259
19.42	19,577	K713_0290	MR300/210	213/215/TC	AW300/110	29.285	3,765	17.13	20,844	13.98	21,259	10.49	21,259
22.21	22,364	K813_0290	MR200/180	182/184/TC	AW200/014	29.254	4,962	19.37	23,534	15.49	23,534	11.62	23,534
31.69	31,904	K813_0290	MR250/210	213/215/TC	AW250/102	29.254	4,962	26.25	31,904	21.00	31,904	15.75	31,904
33.65	33,876	K813_0290	MR300/250	254/256TC	AW300/110	29.254	4,962	29.68	36,067	24.49	37,204	18.37	37,204

### Part No. Explanation

**K 4 0 2 V G 0690 AW 160 /012**

K: Right Angle Helical/Bevel  
 4: Unit No.  
 0: Generation No.  
 2: No. of Gear Reductions  
 V: Output Style (A-hollow; V-solid)  
 G: Housing Style  
 0690: Ratio (0690 = 69.0:1)  
 AW: Input Shaft  
 160: Flange No.  
 012: Shaft Dia. (1/16 in.; example - 012 = 12/16 or 3/4)

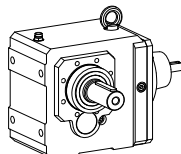

**K 4 0 2 V G 0690 MR 160 /140**

K: Right Angle Helical/Bevel  
 4: Unit No.  
 0: Generation No.  
 2: No. of Reductions  
 V: Output Style (A-hollow; V-solid)  
 G: Housing Style  
 0690: Ratio (0690 = 69.0:1)  
 MR: Motor Adapter  
 160: Flange No.  
 140: Motor Frame Size (140=143/145TC)

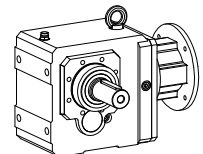

**Mounting position must be specified when ordering.**





# "K" Series – Right Angle Helical/Bevel MGS Reducer – Selection Data



### Selection Procedure:

- Under the Input RPM heading, find **Approximate Output RPM** nearest the requirement.
- In the **Input HP** column locate the rating that is greater than or equal to the required HP.  
(If selection is based on Torque instead of HP, find an **Output Torque** that is equal to or greater than required.)
- When HP or Torque rating is located, read across that row to select the **Base Module**, **Input Option** and **Overhung Loads**.
- If exact **Output RPM** is required, divide the **Input RPM** by the **Exact Ratio**.

1750 RPM Input		Base Module <sup>1)</sup>	Input Options <sup>2)</sup>			Exact Ratio	Overhung Load Output Shaft <sup>3)</sup> lbs.	1450 RPM Input		1160 RPM Input		870 RPM Input	
Input HP	Output Torque in. lbs.		Motor Adapter	NEMA C-Frame Size <sup>4)</sup>	Input Shaft			Input HP	Output Torque in. lbs.	Input HP	Output Torque in. lbs.	Input HP	Output Torque in. lbs.
<b>55 RPM Output (Approximate)</b>													
2.76	3,100	K303_0330	MR160/050	56C	AW160/012	32.649	1,231	2.29	3,100	1.83	3,100	1.37	3,100
2.76	3,100	K303_0330	MR160/140	143/145TC	AW160/012	32.649	1,231	2.29	3,100	1.83	3,100	1.37	3,100
3.13	3,489	K403_0320	MR160/050	56C	AW160/012	32.390	1,966	2.59	3,489	2.07	3,489	1.56	3,489
3.13	3,489	K403_0320	MR160/140	143/145TC	AW160/012	32.390	1,966	2.59	3,489	2.07	3,489	1.56	3,489
7.17	7,972	K513_0320	MR160/050	56C	AW160/012	32.308	2,359	5.94	7,972	4.75	7,972	3.56	7,972
7.17	7,972	K513_0320	MR160/140	143/145TC	AW160/012	32.308	2,359	5.94	7,972	4.75	7,972	3.56	7,972
7.17	7,972	K513_0320	MR200/180	182/184TC	AW200/014	32.308	2,359	5.94	7,972	4.75	7,972	3.56	7,972
7.17	7,972	K513_0320	MR250/180	182/184TC	AW250/102	32.308	2,359	5.94	7,972	4.75	7,972	3.56	7,972
9.70	10,635	K613_0320	MR160/050	56C	AW160/012	31.855	2,796	8.15	10,790	6.52	10,790	4.89	10,790
9.70	10,635	K613_0320	MR160/140	143/145TC	AW160/012	31.855	2,796	8.15	10,790	6.52	10,790	4.89	10,790
11.22	12,303	K613_0320	MR200/180	182/184TC	AW200/014	31.855	2,796	9.71	12,844	7.77	12,844	5.82	12,844
11.22	12,303	K613_0320	MR250/180	182/184TC	AW250/102	31.855	2,796	9.71	12,844	7.77	12,844	5.82	12,844
11.22	12,303	K613_0320	MR300/250	254/256TC	AW300/110	31.855	2,796	9.71	12,844	7.77	12,844	5.82	12,844
18.15	20,253	K713_0320	MR200/180	182/184TC	AW200/014	32.423	3,862	15.78	21,259	12.63	21,259	9.47	21,259
18.15	20,253	K713_0320	MR250/210	213/215TC	AW250/102	32.423	3,862	15.78	21,259	12.63	21,259	9.47	21,259
18.15	20,253	K713_0320	MR300/210	213/215TC	AW300/110	32.423	3,862	15.78	21,259	12.63	21,259	9.47	21,259
22.21	24,760	K813_0320	MR200/180	182/184TC	AW200/014	32.389	5,090	19.37	26,056	15.49	26,056	11.62	26,056
31.44	35,045	K813_0320	MR250/180	182/184TC	AW250/102	32.389	5,090	26.25	35,323	21.00	35,323	15.75	35,323
31.44	35,045	K813_0320	MR300/210	213/215TC	AW300/110	32.389	5,090	27.65	37,204	22.12	37,204	16.59	37,204
33.01	36,492	K913_0320	MR250/180	182/184TC	AW250/102	32.116	11,383	27.35	36,492	21.88	36,492	16.41	36,492
56.10*	62,006	K913_0320	MR300/280	284/286TC	AW300/110	32.116	11,383	46.48	62,006	37.18	62,006	27.89	62,006
56.10*	62,006	K913_0320	MR350/360	364/365TC	AW350/202	32.116	11,383	46.48	62,006	37.18	62,006	27.89	62,006
66.07	71,710	K1013_0320	MR300/250	254/256TC	AW300/110	31.535	13,947	54.74	71,710	43.80	71,710	32.85	71,710
77.94*	106,296	K1013_0320	MR350/360	364/365TC	AW350/202	31.535	13,947	81.15	106,296	64.92	106,296	48.69	106,296
<b>50 RPM Output (Approximate) Continued Next Page</b>													
<b>40 RPM 33 RPM 25 RPM</b>													
0.55	647	K102_0340	MR140/050	56C	AW140/010	33.707	886	0.45	647	0.36	647	0.27	647
0.87	1,063	K102_0350	MR140/050	56C	AW140/010	35.105	895	0.72	1,063	0.57	1,063	0.43	1,063
0.87	1,063	K102_0350	MR160/050	56C	AW160/012	35.105	895	0.72	1,063	0.57	1,063	0.43	1,063
1.16	1,364	K202_0340	MR140/050	56C	AW140/010	33.618	1,063	0.96	1,364	0.77	1,364	0.58	1,364
1.16	1,364	K202_0340	MR160/050	56C	AW160/012	33.618	1,063	0.96	1,364	0.77	1,364	0.58	1,364
1.16	1,364	K202_0340	MR160/140	143/145TC	AW160/012	33.618	1,063	0.96	1,364	0.77	1,364	0.58	1,364
1.47	1,772	K202_0350	MR140/050	56C	AW140/010	34.554	1,070	1.22	1,772	0.97	1,772	0.73	1,772
1.47	1,772	K202_0350	MR160/050	56C	AW160/012	34.554	1,070	1.22	1,772	0.97	1,772	0.73	1,772
1.47	1,772	K202_0350	MR160/140	143/145TC	AW160/012	34.554	1,070	1.22	1,772	0.97	1,772	0.73	1,772
1.89	2,217	K302_0340	MR140/050	56C	AW140/010	33.618	1,240	1.56	2,217	1.25	2,217	0.94	2,217
1.89	2,217	K302_0340	MR160/050	56C	AW160/012	33.618	1,240	1.56	2,217	1.25	2,217	0.94	2,217
1.89	2,217	K302_0340	MR160/140	143/145TC	AW160/012	33.618	1,240	1.56	2,217	1.25	2,217	0.94	2,217
2.13	2,581	K302_0350	MR140/050	56C	AW140/010	34.731	1,250	1.76	2,581	1.41	2,581	1.06	2,581
2.51	3,100	K303_0360	MR160/050	56C	AW160/012	35.833	1,260	2.08	3,100	1.67	3,100	1.25	3,100

\* For thermal HP capacity, see rating below.

Base Module	K1	K2	K3	K4	K5	K6	K7	K8	K9	K10
Thermal Capacity	2.95	5.36	7.38	12.34	14.75	20.12	29.50	40.23	53.64	67.05

NEMA Frame Size  
TEFC 1750 RPM

C-Frame	Motor HP
56C	1/3 - 1 1/2
143/145TC	1, 1 1/2, 2
182/184TC	3, 5
213/215TC	7 1/2, 10
254/256TC	15, 20
284/286TC	25, 30
324/326TC	40, 50
364/365TC	60, 75

### Housing Styles

N – Foot Mounted    F – Round Flange    G – Tapped Holes    GD – Torque Arm Bracket

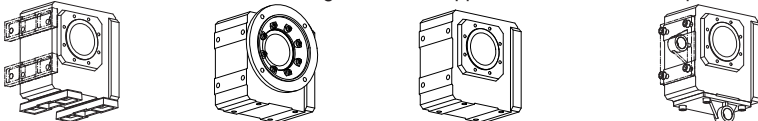

These Housing Styles are available as Hollow (A) or Solid (V) Output.





# "K" Series – Right Angle Helical/Bevel MGS Reducer – Selection Data



- NOTE:** 1) Complete Base Module Part Number by adding Output and Housing Style. Example: K302VG0560.  
 2) Select Input Option and add to completed Part Number. See example below.  
 3) Overhung Load is measured at the center of the shaft extension. Hollow output units are not intended to support overhung loads. If a load rating is required, use 50% of the published overhung load.  
 4) Other frame sizes may also be available. See dimension pages.

1750 RPM Input		Base Module <sup>1)</sup>	Input Options <sup>2)</sup>			Exact Ratio	Overhung Load Output Shaft <sup>3)</sup> lbs.	1450 RPM Input		1160 RPM Input		870 RPM Input	
Input HP	Output Torque in. lbs.		Motor Adapter	NEMA C-Frame Size <sup>4)</sup>	Input Shaft			Input HP	Output Torque in. lbs.	Input HP	Output Torque in. lbs.	Input HP	Output Torque in. lbs.
<b>50 RPM Output (Approximate) Continued</b>													
				<b>40 RPM</b>				<b>33 RPM</b>		<b>25 RPM</b>			
2.51	3,100	K303_0360	MR160/140	143/145TC	AW160/012	35.833	1,260	2.08	3,100	1.67	3,100	1.25	3,100
2.55	3,100	K302_0350	MR160/050	56C	AW160/012	34.731	1,250	2.12	3,100	1.69	3,100	1.27	3,100
2.55	3,100	K302_0350	MR160/140	143/145TC	AW160/012	34.731	1,250	2.12	3,100	1.69	3,100	1.27	3,100
2.93	3,445	K402_0340	MR160/050	56C	AW160/012	33.678	1,985	2.43	3,445	1.94	3,445	1.46	3,445
2.93	3,445	K402_0340	MR160/140	143/145TC	AW160/012	33.678	1,985	2.43	3,445	1.94	3,445	1.46	3,445
3.24	3,985	K403_0360	MR160/050	56C	AW160/012	35.721	2,014	2.69	3,985	2.15	3,985	1.61	3,985
3.24	3,985	K403_0360	MR160/140	143/145TC	AW160/012	35.721	2,014	2.69	3,985	2.15	3,985	1.61	3,985
4.01	4,872	K402_0350	MR160/050	56C	AW160/012	34.758	2,001	3.32	4,872	2.66	4,872	1.99	4,872
4.01	4,872	K402_0350	MR160/140	143/145TC	AW160/012	34.758	2,001	3.32	4,872	2.66	4,872	1.99	4,872
4.01	4,872	K402_0350	MR200/180	182/184TC	AW200/014	34.758	2,001	3.32	4,872	2.66	4,872	1.99	4,872
4.01	4,872	K402_0350	MR250/180	182/184TC	AW250/102	34.758	2,001	3.32	4,872	2.66	4,872	1.99	4,872
6.66	7,972	K513_0350	MR160/050	56C	AW160/012	34.800	2,403	5.52	7,972	4.41	7,972	3.31	7,972
6.66	7,972	K513_0350	MR160/140	143/145TC	AW160/012	34.800	2,403	5.52	7,972	4.41	7,972	3.31	7,972
6.66	7,972	K513_0350	MR200/180	182/184TC	AW200/014	34.800	2,403	5.52	7,972	4.41	7,972	3.31	7,972
6.66	7,972	K513_0350	MR250/210	213/215TC	AW250/102	34.800	2,403	5.52	7,972	4.41	7,972	3.31	7,972
8.15	9,711	K613_0350	MR160/050	56C	AW160/012	34.610	2,855	7.19	10,339	6.20	11,138	4.89	11,723
8.15	9,711	K613_0350	MR160/140	143/145TC	AW160/012	34.610	2,855	7.19	10,339	6.20	11,138	4.89	11,723
10.62	12,647	K613_0350	MR200/180	182/184TC	AW200/014	34.610	2,855	8.93	12,844	7.15	12,844	5.36	12,844
10.62	12,647	K613_0350	MR250/180	182/184TC	AW250/102	34.610	2,855	8.93	12,844	7.15	12,844	5.36	12,844
10.62	12,647	K613_0350	MR300/250	254/256TC	AW300/110	34.610	2,855	8.93	12,844	7.15	12,844	5.36	12,844
15.97	19,477	K713_0350	MR200/180	182/184TC	AW200/014	35.438	3,949	14.09	20,737	11.55	21,259	8.67	21,259
17.10	20,862	K713_0350	MR250/180	182/184TC	AW250/102	35.438	3,949	14.44	21,259	11.55	21,259	8.67	21,259
17.10	20,862	K713_0350	MR300/250	254/256TC	AW300/110	35.438	3,949	14.44	21,259	11.55	21,259	8.67	21,259
18.58	23,110	K813_0360	MR200/180	182/184TC	AW200/014	36.138	5,231	16.39	24,605	14.13	26,505	11.62	29,072
29.22	36,348	K813_0360	MR250/180	182/184TC	AW250/102	36.138	5,231	24.78	37,204	19.83	37,204	14.87	37,204
29.22	36,348	K813_0360	MR300/280	284/286TC	AW300/110	36.138	5,231	24.78	37,204	19.83	37,204	14.87	37,204
<b>45 RPM Output (Approximate) Continued Next Page</b>													
				<b>35 RPM</b>				<b>30 RPM</b>		<b>23 RPM</b>			
0.39	544	K102_0400	MR140/050	56C	AW140/010	40.300	927	0.32	544	0.26	544	0.19	544
0.72	1,023	K202_0400	MR140/050	56C	AW140/010	40.394	1,113	0.60	1,023	0.48	1,023	0.36	1,023
1.07	1,455	K203_0390	MR140/050	56C	AW140/010	39.454	1,106	0.89	1,455	0.71	1,455	0.53	1,455
1.20	1,705	K302_0410	MR140/050	56C	AW140/010	40.512	1,299	1.00	1,705	0.80	1,705	0.60	1,705
1.20	1,705	K302_0410	MR160/050	56C	AW160/012	40.512	1,299	1.00	1,705	0.80	1,705	0.60	1,705
1.20	1,705	K302_0410	MR160/140	143/145TC	AW160/012	40.512	1,299	1.00	1,705	0.80	1,705	0.60	1,705
1.93	2,729	K402_0410	MR160/050	56C	AW160/012	40.512	2,079	1.60	2,729	1.28	2,729	0.96	2,729
1.93	2,729	K402_0410	MR160/140	143/145TC	AW160/012	40.512	2,079	1.60	2,729	1.28	2,729	0.96	2,729
2.30	3,100	K303_0390	MR160/050	56C	AW160/012	39.187	1,288	1.90	3,100	1.52	3,100	1.14	3,100
2.30	3,100	K303_0390	MR160/140	143/145TC	AW160/012	39.187	1,288	1.90	3,100	1.52	3,100	1.14	3,100
3.03	4,077	K403_0390	MR160/050	56C	AW160/012	39.047	2,060	2.51	4,077	2.01	4,077	1.51	4,077
3.03	4,077	K403_0390	MR160/140	143/145TC	AW160/012	39.047	2,060	2.51	4,077	2.01	4,077	1.51	4,077

### Part No. Explanation

**K 4 0 2 V G 0690 AW 160 /012**

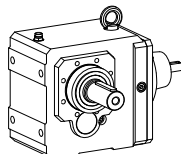
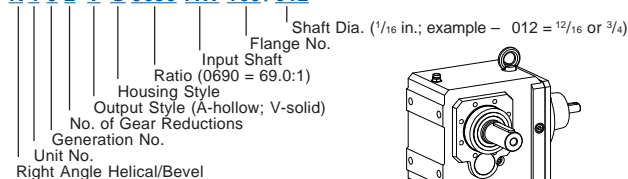

**K 4 0 2 V G 0690 MR 160 /140**

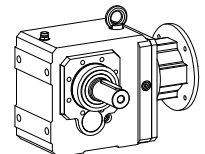
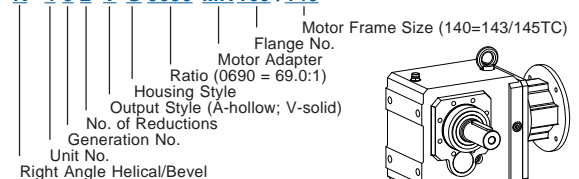

**Mounting position must be specified when ordering.**



# "K" Series – Right Angle Helical/Bevel MGS Reducer – Selection Data



### Selection Procedure:

- Under the Input RPM heading, find **Approximate Output RPM** nearest the requirement.
- In the **Input HP** column locate the rating that is greater than or equal to the required HP.  
(If selection is based on Torque instead of HP, find an **Output Torque** that is equal to or greater than required.)
- When HP or Torque rating is located, read across that row to select the **Base Module**, **Input Option** and **Overhung Loads**.
- If exact **Output RPM** is required, divide the **Input RPM** by the **Exact Ratio**.

1750 RPM Input		Base Module <sup>1)</sup>	Input Options <sup>2)</sup>			Exact Ratio	Overhung Load Output Shaft <sup>3)</sup> lbs.	1450 RPM Input		1160 RPM Input		870 RPM Input	
Input HP	Output Torque in. lbs.		Motor Adapter	NEMA C-Frame Size <sup>4)</sup>	Input Shaft			Input HP	Output Torque in. lbs.	Input HP	Output Torque in. lbs.	Input HP	Output Torque in. lbs.

45 RPM Output (Approximate) Continued						35 RPM		30 RPM		23 RPM			
6.01	7,972	K513_0390	MR160/050	56C	AW160/012	38.529	2,465	4.98	7,972	3.98	7,972	2.99	7,972
6.01	7,972	K513_0390	MR160/140	143/145TC	AW160/012	38.529	2,465	4.98	7,972	3.98	7,972	2.99	7,972
6.01	7,972	K513_0390	MR200/180	182/184/TC	AW200/014	38.529	2,465	4.98	7,972	3.98	7,972	2.99	7,972
6.01	7,972	K513_0390	MR250/180	182/184/TC	AW250/102	38.529	2,465	4.98	7,972	3.98	7,972	2.99	7,972
6.81	10,099	K613_0430	MR160/050	56C	AW160/012	43.111	3,016	6.00	10,752	5.17	11,582	4.27	12,748
6.81	10,099	K613_0430	MR160/140	143/145TC	AW160/012	43.111	3,016	6.00	10,752	5.17	11,582	4.27	12,748
8.15	10,752	K613_0380	MR160/050	56C	AW160/012	38.319	2,929	7.19	11,448	6.20	12,331	4.84	12,844
8.15	10,752	K613_0380	MR160/140	143/145TC	AW160/012	38.319	2,929	7.19	11,448	6.20	12,331	4.84	12,844
8.66	12,844	K613_0430	MR200/180	182/184/TC	AW200/014	43.111	3,016	7.17	12,844	5.74	12,844	4.30	12,844
8.66	12,844	K613_0430	MR250/210	213/215/TC	AW250/102	43.111	3,016	7.17	12,844	5.74	12,844	4.30	12,844
9.74	12,844	K613_0380	MR200/180	182/184/TC	AW200/014	38.319	2,929	8.07	12,844	6.46	12,844	4.84	12,844
9.74	12,844	K613_0380	MR250/180	182/184/TC	AW250/102	38.319	2,929	8.07	12,844	6.46	12,844	4.84	12,844
9.74	12,844	K613_0380	MR300/180	182/184/TC	AW300/110	38.319	2,929	8.07	12,844	6.46	12,844	4.84	12,844
15.74	21,259	K713_0390	MR200/180	182/184/TC	AW200/014	39.234	4,051	13.04	21,259	10.44	21,259	7.83	21,259
15.74	21,259	K713_0390	MR250/180	182/184/TC	AW250/102	39.234	4,051	13.04	21,259	10.44	21,259	7.83	21,259
15.74	21,259	K713_0390	MR300/180	182/184/TC	AW300/110	39.234	4,051	13.04	21,259	10.44	21,259	7.83	21,259
18.58	25,586	K813_0400	MR200/180	182/184/TC	AW200/014	40.009	5,366	16.39	27,241	14.13	29,344	11.62	32,187
27.02	37,204	K813_0400	MR250/180	182/184/TC	AW250/102	40.009	5,366	22.39	37,204	17.91	37,204	13.43	37,204
27.02	37,204	K813_0400	MR300/210	213/215/TC	AW300/110	40.009	5,366	22.39	37,204	17.91	37,204	13.43	37,204
31.91	41,786	K913_0380	MR250/210	213/215/TC	AW250/102	38.042	11,876	26.44	41,786	21.15	41,786	15.87	41,786
47.36	62,006	K913_0380	MR300/280	284/286TC	AW300/110	38.042	11,876	39.24	62,006	31.39	62,006	23.54	62,006
47.36	62,006	K913_0380	MR350/320	324/326TC	AW350/202	38.042	11,876	39.24	62,006	31.39	62,006	23.54	62,006
63.23	83,998	K1013_0390	MR300/250	254/256TC	AW300/110	38.601	14,670	52.39	83,998	41.91	83,998	31.43	83,998
80.01*	106,296	K1013_0390	MR350/320	324/326TC	AW350/202	38.601	14,670	66.29	106,296	53.03	106,296	39.78	106,296

40 RPM Output (Approximate) Continued Next Page						30 RPM		25 RPM		20 RPM			
1.07	1,667	K203_0450	MR140/050	56C	AW140/010	45.223	1,145	0.89	1,667	0.71	1,667	0.53	1,667
1.10	1,772	K202_0460	MR140/050	56C	AW140/010	46.225	1,151	0.91	1,772	0.73	1,772	0.55	1,772
1.10	1,772	K202_0460	MR160/050	56C	AW160/012	46.225	1,151	0.91	1,772	0.73	1,772	0.55	1,772
1.10	1,772	K202_0460	MR160/140	143/145TC	AW160/012	46.225	1,151	0.91	1,772	0.73	1,772	0.55	1,772
1.89	3,048	K302_0460	MR140/050	56C	AW140/010	46.225	1,343	1.56	3,048	1.25	3,048	0.94	3,048
1.89	3,048	K302_0460	MR160/050	56C	AW160/012	46.225	1,343	1.56	3,048	1.25	3,048	0.94	3,048
1.89	3,048	K302_0460	MR160/140	143/145TC	AW160/012	46.225	1,343	1.56	3,048	1.25	3,048	0.94	3,048
2.01	3,100	K303_0450	MR160/050	56C	AW160/012	44.892	1,333	1.66	3,100	1.33	3,100	1.00	3,100
2.01	3,100	K303_0450	MR160/140	143/145TC	AW160/012	44.892	1,333	1.66	3,100	1.33	3,100	1.00	3,100
2.93	4,737	K402_0460	MR160/050	56C	AW160/012	46.308	2,149	2.43	4,737	1.94	4,737	1.46	4,737
2.93	4,737	K402_0460	MR160/140	143/145TC	AW160/012	46.308	2,149	2.43	4,737	1.94	4,737	1.46	4,737
3.13	4,798	K403_0450	MR160/050	56C	AW160/012	44.536	2,129	2.59	4,798	2.07	4,798	1.56	4,798
3.13	4,798	K403_0450	MR160/140	143/145TC	AW160/012	44.536	2,129	2.59	4,798	2.07	4,798	1.56	4,798
5.32	7,972	K513_0440	MR160/050	56C	AW160/012	43.500	2,541	4.41	7,972	3.53	7,972	2.65	7,972

\* For thermal HP capacity, see rating below.

Base Module	K1	K2	K3	K4	K5	K6	K7	K8	K9	K10
Thermal Capacity	2.95	5.36	7.38	12.34	14.75	20.12	29.50	40.23	53.64	67.05

NEMA Frame Size  
TEFC 1750 RPM

C-Frame	Motor HP
56C	1/3 - 1 1/2
143/145TC	1, 1 1/2, 2
182/184TC	3, 5
213/215TC	7 1/2, 10
254/256TC	15, 20
284/286TC	25, 30
324/326TC	40, 50
364/365TC	60, 75

### Housing Styles

N – Foot Mounted    F – Round Flange    G – Tapped Holes    GD – Torque Arm Bracket

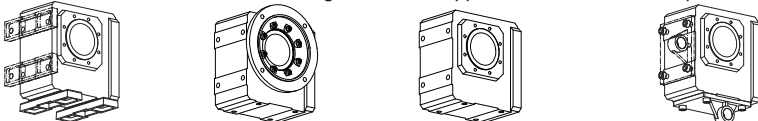

These Housing Styles are available as Hollow (A) or Solid (V) Output.



# "K" Series – Right Angle Helical/Bevel MGS Reducer – Selection Data



- NOTE:** 1) Complete Base Module Part Number by adding Output and Housing Style. Example: K302VG0560.  
 2) Select Input Option and add to completed Part Number. See example below.  
 3) Overhung Load is measured at the center of the shaft extension. Hollow output units are not intended to support overhung loads. If a load rating is required, use 50% of the published overhung load.  
 4) Other frame sizes may also be available. See dimension pages.

1750 RPM Input		Base Module <sup>1)</sup>	Input Options <sup>2)</sup>			Exact Ratio	Overhung Load Output Shaft <sup>3)</sup> lbs.	1450 RPM Input		1160 RPM Input		870 RPM Input	
Input HP	Output Torque in. lbs.		Motor Adapter	NEMA C-Frame Size <sup>4)</sup>	Input Shaft			Input HP	Output Torque in. lbs.	Input HP	Output Torque in. lbs.	Input HP	Output Torque in. lbs.
<b>40 RPM Output (Approximate) Continued</b>													
5.32	7,972	K513_0440	MR160/140	143/145TC	AW160/012	43.500	2,541	4.41	7,972	3.53	7,972	2.65	7,972
5.32	7,972	K513_0440	MR200/180	182/184/TC	AW200/014	43.500	2,541	4.41	7,972	3.53	7,972	2.65	7,972
5.32	7,972	K513_0440	MR250/180	182/184/TC	AW250/102	43.500	2,541	4.41	7,972	3.53	7,972	2.65	7,972
13.16	20,403	K713_0450	MR200/180	182/184/TC	AW200/014	45.054	4,193	11.36	21,259	9.09	21,259	6.82	21,259
13.71	21,259	K713_0450	MR250/210	213/215/TC	AW250/102	45.054	4,193	11.36	21,259	9.09	21,259	6.82	21,259
13.71	21,259	K713_0450	MR300/280	284/286TC	AW300/110	45.054	4,193	11.36	21,259	9.09	21,259	6.82	21,259
15.97	24,320	K813_0440	MR200/180	182/184/TC	AW200/014	44.250	5,502	14.09	25,894	12.14	27,893	10.02	30,700
24.43	37,204	K813_0440	MR250/180	182/184/TC	AW250/102	44.250	5,502	20.24	37,204	16.19	37,204	12.14	37,204
24.43	37,204	K813_0440	MR300/210	213/215/TC	AW300/110	44.250	5,502	20.24	37,204	16.19	37,204	12.14	37,204
<b>35 RPM Output (Approximate)</b>													
0.25	442	K102_0500	MR140/050	56C	AW140/010	50.310	980	0.21	442	0.17	442	0.13	442
0.48	853	K202_0500	MR140/050	56C	AW140/010	50.492	1,177	0.40	853	0.32	853	0.24	853
0.55	900	K102_0470	MR140/050	56C	AW140/010	46.918	963	0.45	900	0.36	900	0.27	900
0.77	1,364	K302_0500	MR140/050	56C	AW140/010	50.492	1,373	0.64	1,364	0.51	1,364	0.38	1,364
1.02	1,772	K203_0500	MR140/050	56C	AW140/010	49.759	1,172	0.84	1,772	0.68	1,772	0.51	1,772
1.07	1,816	K303_0490	MR140/050	56C	AW140/010	49.260	1,364	0.89	1,816	0.71	1,816	0.53	1,816
1.35	2,387	K402_0500	MR160/050	56C	AW160/012	50.427	2,196	1.12	2,387	0.90	2,387	0.67	2,387
1.35	2,387	K402_0500	MR160/140	143/145TC	AW160/012	50.427	2,196	1.12	2,387	0.90	2,387	0.67	2,387
1.85	3,100	K303_0490	MR160/050	56C	AW160/012	48.631	1,360	1.53	3,100	1.23	3,100	0.92	3,100
1.85	3,100	K303_0490	MR160/140	143/145TC	AW160/012	48.631	1,360	1.53	3,100	1.23	3,100	0.92	3,100
2.89	4,872	K403_0490	MR160/050	56C	AW160/012	48.944	2,179	2.40	4,872	1.92	4,872	1.44	4,872
2.89	4,872	K403_0490	MR160/140	143/145TC	AW160/012	48.944	2,179	2.40	4,872	1.92	4,872	1.44	4,872
4.81	7,972	K513_0480	MR160/050	56C	AW160/012	48.161	2,607	3.98	7,972	3.19	7,972	2.39	7,972
4.81	7,972	K513_0480	MR160/140	143/145TC	AW160/012	48.161	2,607	3.98	7,972	3.19	7,972	2.39	7,972
4.81	7,972	K513_0480	MR200/180	182/184/TC	AW200/014	48.161	2,607	3.98	7,972	3.19	7,972	2.39	7,972
4.81	7,972	K513_0480	MR250/180	182/184/TC	AW250/102	48.161	2,607	3.98	7,972	3.19	7,972	2.39	7,972
6.81	11,181	K613_0480	MR160/050	56C	AW160/012	47.730	3,094	6.00	11,904	5.17	12,823	3.89	12,844
6.81	11,181	K613_0480	MR160/140	143/145TC	AW160/012	47.730	3,094	6.00	11,904	5.17	12,823	3.89	12,844
7.82	12,844	K613_0480	MR200/180	182/184/TC	AW200/014	47.730	3,094	6.48	12,844	5.18	12,844	3.89	12,844
7.82	12,844	K613_0480	MR250/210	213/215/TC	AW250/102	47.730	3,094	6.48	12,844	5.18	12,844	3.89	12,844
12.38	21,259	K713_0500	MR200/180	182/184/TC	AW200/014	49.881	4,301	10.26	21,259	8.21	21,259	6.16	21,259
12.38	21,259	K713_0500	MR250/210	213/215/TC	AW250/102	49.881	4,301	10.26	21,259	8.21	21,259	6.16	21,259
12.38	21,259	K713_0500	MR300/250	254/256TC	AW300/110	49.881	4,301	10.26	21,259	8.21	21,259	6.16	21,259
15.97	26,926	K813_0490	MR200/180	182/184/TC	AW200/014	48.991	5,644	14.09	28,668	12.14	30,882	10.02	33,989
22.06	37,204	K813_0490	MR250/210	213/215/TC	AW250/102	48.991	5,644	18.28	37,204	14.63	37,204	10.97	37,204
22.06	37,204	K813_0490	MR300/280	284/286TC	AW300/110	48.991	5,644	18.28	37,204	14.63	37,204	10.97	37,204
30.30	51,041	K913_0490	MR250/180	182/184/TC	AW250/102	48.937	12,647	25.11	51,041	20.09	51,041	15.07	51,041
36.81	62,006	K913_0490	MR300/280	284/286TC	AW300/110	48.937	12,647	30.50	62,006	24.40	62,006	18.30	62,006
60.30	100,751	K1013_0490	MR300/250	254/256TC	AW300/110	48.543	15,535	49.96	100,751	39.97	100,751	29.98	100,751
63.62	106,296	K1013_0490	MR350/320	324/326TC	AW350/202	48.543	15,535	52.71	106,296	42.17	106,296	31.63	106,296

### Part No. Explanation

**K 4 0 2 V G 0690 AW 160 /012**

K: Right Angle Helical/Bevel  
 4: Unit No.  
 0: Generation No.  
 2: No. of Gear Reductions  
 V: Output Style (A-hollow; V-solid)  
 G: Housing Style  
 0690: Ratio (0690 = 69.0:1)  
 AW: Input Shaft  
 160: Flange No.  
 012: Shaft Dia. (1/16 in.; example - 012 = 12/16 or 3/4)

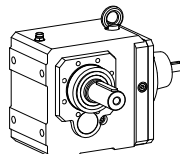

**K 4 0 2 V G 0690 MR 160 /140**

K: Right Angle Helical/Bevel  
 4: Unit No.  
 0: Generation No.  
 2: No. of Reductions  
 V: Output Style (A-hollow; V-solid)  
 G: Housing Style  
 0690: Ratio (0690 = 69.0:1)  
 MR: Motor Adapter  
 160: Flange No.  
 140: Motor Frame Size (140=143/145TC)

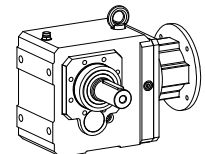

**Mounting position must be specified when ordering.**





# "K" Series – Right Angle Helical/Bevel MGS Reducer – Selection Data



### Selection Procedure:

- Under the Input RPM heading, find **Approximate Output RPM** nearest the requirement.
- In the **Input HP** column locate the rating that is greater than or equal to the required HP.  
(If selection is based on Torque instead of HP, find an **Output Torque** that is equal to or greater than required.)
- When HP or Torque rating is located, read across that row to select the **Base Module**, **Input Option** and **Overhung Loads**.
- If exact **Output RPM** is required, divide the **Input RPM** by the **Exact Ratio**.

1750 RPM Input		Base Module <sup>1)</sup>	Input Options <sup>2)</sup>			Exact Ratio	Overhung Load Output Shaft <sup>3)</sup> lbs.	1450 RPM Input		1160 RPM Input		870 RPM Input	
Input HP	Output Torque in. lbs.		Motor Adapter	NEMA C-Frame Size <sup>4)</sup>	Input Shaft			Input HP	Output Torque in. lbs.	Input HP	Output Torque in. lbs.	Input HP	Output Torque in. lbs.
<b>30 RPM Output (Approximate)</b>													
0.39	758	K102_0560	MR140/050	56C	AW140/010	56.095	1,007	0.32	758	0.26	758	0.19	758
0.72	1,407	K202_0560	MR140/050	56C	AW140/010	55.542	1,205	0.60	1,407	0.48	1,407	0.36	1,407
0.95	1,772	K203_0540	MR140/050	56C	AW140/010	54.250	1,198	0.79	1,772	0.63	1,772	0.47	1,772
1.07	2,012	K303_0550	MR140/050	56C	AW140/010	54.579	1,400	0.89	2,012	0.71	2,012	0.53	2,012
1.20	2,345	K302_0560	MR140/050	56C	AW140/010	55.705	1,407	1.00	2,345	0.80	2,345	0.60	2,345
1.20	2,345	K302_0560	MR160/050	56C	AW160/012	55.705	1,407	1.00	2,345	0.80	2,345	0.60	2,345
1.20	2,345	K302_0560	MR160/140	143/145TC	AW160/012	55.705	1,407	1.00	2,345	0.80	2,345	0.60	2,345
1.67	3,100	K303_0540	MR160/050	56C	AW160/012	53.883	1,395	1.39	3,100	1.11	3,100	0.83	3,100
1.67	3,100	K303_0540	MR160/140	143/145TC	AW160/012	53.883	1,395	1.39	3,100	1.11	3,100	0.83	3,100
1.93	3,752	K402_0560	MR160/050	56C	AW160/012	55.705	2,251	1.60	3,752	1.28	3,752	0.96	3,752
1.93	3,752	K402_0560	MR160/140	143/145TC	AW160/012	55.705	2,251	1.60	3,752	1.28	3,752	0.96	3,752
2.64	4,872	K403_0540	MR160/050	56C	AW160/012	53.690	2,230	2.18	4,872	1.75	4,872	1.31	4,872
2.64	4,872	K403_0540	MR160/140	143/145TC	AW160/012	53.690	2,230	2.18	4,872	1.75	4,872	1.31	4,872
3.97	7,972	K513_0580	MR160/050	56C	AW160/012	58.297	2,734	3.29	7,972	2.63	7,972	1.98	7,972
3.97	7,972	K513_0580	MR160/140	143/145TC	AW160/012	58.297	2,734	3.29	7,972	2.63	7,972	1.98	7,972
3.97	7,972	K513_0580	MR200/180	182/184TC	AW200/014	58.297	2,734	3.29	7,972	2.63	7,972	1.98	7,972
3.97	7,972	K513_0580	MR250/210	213/215TC	AW250/102	58.297	2,734	3.29	7,972	2.63	7,972	1.98	7,972
5.27	10,436	K613_0580	MR160/050	56C	AW160/012	57.545	3,242	4.65	11,111	4.01	11,969	3.22	12,844
5.27	10,436	K613_0580	MR160/140	143/145TC	AW160/012	57.545	3,242	4.65	11,111	4.01	11,969	3.22	12,844
6.49	12,844	K613_0580	MR200/180	182/184TC	AW200/014	57.545	3,242	5.37	12,844	4.30	12,844	3.22	12,844
6.49	12,844	K613_0580	MR250/180	182/184TC	AW250/102	57.545	3,242	5.37	12,844	4.30	12,844	3.22	12,844
10.55	21,259	K713_0590	MR200/180	182/184TC	AW200/014	58.570	4,477	8.74	21,259	6.99	21,259	5.24	21,259
10.55	21,259	K713_0590	MR250/210	213/215TC	AW250/102	58.570	4,477	8.74	21,259	6.99	21,259	5.24	21,259
10.55	21,259	K713_0590	MR300/250	254/256TC	AW300/110	58.570	4,477	8.74	21,259	6.99	21,259	5.24	21,259
12.55	25,527	K813_0590	MR200/180	182/184TC	AW200/014	59.082	5,915	11.07	27,179	9.54	29,277	7.88	32,224
18.30	37,204	K813_0590	MR250/180	182/184TC	AW250/102	59.082	5,915	15.16	37,204	12.13	37,204	9.10	37,204
18.30	37,204	K813_0590	MR300/250	254/256TC	AW300/110	59.082	5,915	15.16	37,204	12.13	37,204	9.10	37,204

<b>25 RPM Output (Approximate) Continued Next Page</b>													
<b>20 RPM</b>													
<b>18 RPM</b>													
<b>13 RPM</b>													
0.25	616	K102_0700	MR140/050	56C	AW140/010	70.029	1,064	0.21	616	0.17	616	0.13	616
0.48	1,172	K202_0690	MR140/050	56C	AW140/010	69.427	1,274	0.40	1,172	0.32	1,172	0.24	1,172
0.75	1,772	K203_0680	MR140/050	56C	AW140/010	68.419	1,269	0.62	1,772	0.50	1,772	0.37	1,772
0.77	1,876	K302_0690	MR140/050	56C	AW140/010	69.427	1,486	0.64	1,876	0.51	1,876	0.38	1,876
0.78	1,772	K203_0660	MR140/050	56C	AW140/010	66.027	1,258	0.65	1,772	0.52	1,772	0.39	1,772
1.07	2,513	K403_0680	MR140/050	56C	AW140/010	68.169	2,368	0.89	2,513	0.71	2,513	0.53	2,513
1.07	2,446	K303_0660	MR140/050	56C	AW140/010	66.346	1,470	0.89	2,446	0.71	2,446	0.53	2,446
1.07	2,446	K403_0660	MR140/050	56C	AW140/010	66.346	2,352	0.89	2,446	0.71	2,446	0.53	2,446
1.07	2,497	K303_0680	MR140/050	56C	AW140/010	67.733	1,477	0.89	2,497	0.71	2,497	0.53	2,497
1.35	3,100	K303_0670	MR160/050	56C	AW160/012	66.868	1,473	1.12	3,100	0.89	3,100	0.67	3,100
1.35	3,100	K303_0670	MR160/140	143/145TC	AW160/012	66.868	1,473	1.12	3,100	0.89	3,100	0.67	3,100

\* For thermal HP capacity, see rating below.

Base Module	K1	K2	K3	K4	K5	K6	K7	K8	K9	K10
Thermal Capacity	2.95	5.36	7.38	12.34	14.75	20.12	29.50	40.23	53.64	67.05

NEMA Frame Size  
TEFC 1750 RPM

C-Frame	Motor HP
56C	1/3 - 1 1/2
143/145TC	1, 1 1/2, 2
182/184TC	3, 5
213/215TC	7 1/2, 10
254/256TC	15, 20
284/286TC	25, 30
324/326TC	40, 50
364/365TC	60, 75

### Housing Styles

N – Foot Mounted    F – Round Flange    G – Tapped Holes    GD – Torque Arm Bracket

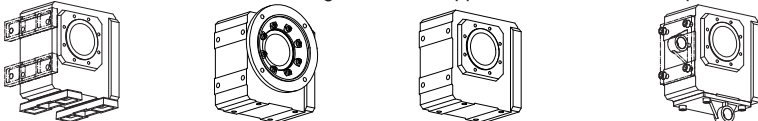

These Housing Styles are available as Hollow (A) or Solid (V) Output.





# "K" Series – Right Angle Helical/Bevel MGS Reducer – Selection Data



- NOTE:** 1) Complete Base Module Part Number by adding Output and Housing Style. Example: K302VG0560.  
 2) Select Input Option and add to completed Part Number. See example below.  
 3) Overhung Load is measured at the center of the shaft extension. Hollow output units are not intended to support overhung loads. If a load rating is required, use 50% of the published overhung load.  
 4) Other frame sizes may also be available. See dimension pages.

1750 RPM Input		Base Module 1)	Input Options 2)			Exact Ratio	Overhung Load Output Shaft <sup>3)</sup> lbs.	1450 RPM Input		1160 RPM Input		870 RPM Input	
Input HP	Output Torque in. lbs.		Motor Adapter	NEMA C-Frame Size 4)	Input Shaft			Input HP	Output Torque in. lbs.	Input HP	Output Torque in. lbs.	Input HP	Output Torque in. lbs.
<b>25 RPM Output (Approximate) Continued</b>													
1.35	3,283	K402_0690	MR160/050	56C	AW160/012	69.338	2,378	1.12	3,283	0.90	3,283	0.67	3,283
1.35	3,283	K402_0690	MR160/140	143/145TC	AW160/012	69.338	2,378	1.12	3,283	0.90	3,283	0.67	3,283
1.38	3,100	K303_0650	MR160/050	56C	AW160/012	65.499	1,465	1.14	3,100	0.91	3,100	0.68	3,100
1.38	3,100	K303_0650	MR160/140	143/145TC	AW160/012	65.499	1,465	1.14	3,100	0.91	3,100	0.68	3,100
2.10	4,872	K403_0670	MR160/050	56C	AW160/012	67.298	2,360	1.74	4,872	1.39	4,872	1.05	4,872
2.10	4,872	K403_0670	MR160/140	143/145TC	AW160/012	67.298	2,360	1.74	4,872	1.39	4,872	1.05	4,872
2.16	4,872	K403_0650	MR160/050	56C	AW160/012	65.499	2,344	1.79	4,872	1.43	4,872	1.07	4,872
2.16	4,872	K403_0650	MR160/140	143/145TC	AW160/012	65.499	2,344	1.79	4,872	1.43	4,872	1.07	4,872
3.01	7,268	K513_0700	MR160/050	56C	AW160/012	70.083	2,863	2.50	7,268	2.00	7,268	1.50	7,268
3.01	7,268	K513_0700	MR160/140	143/145TC	AW160/012	70.083	2,863	2.50	7,268	2.00	7,268	1.50	7,268
3.59	7,972	K513_0650	MR160/050	56C	AW160/012	64.544	2,805	2.97	7,972	2.38	7,972	1.78	7,972
3.59	7,972	K513_0650	MR160/140	143/145TC	AW160/012	64.544	2,805	2.97	7,972	2.38	7,972	1.78	7,972
3.59	7,972	K513_0650	MR200/180	182/184TC	AW200/014	64.544	2,805	2.97	7,972	2.38	7,972	1.78	7,972
3.59	7,972	K513_0650	MR250/180	182/184TC	AW250/102	64.544	2,805	2.97	7,972	2.38	7,972	1.78	7,972
4.60	10,894	K613_0690	MR160/050	56C	AW160/012	68.772	3,390	4.06	11,599	3.26	11,639	2.44	11,639
4.60	10,894	K613_0690	MR160/140	143/145TC	AW160/012	68.772	3,390	4.06	11,599	3.26	11,639	2.44	11,639
4.92	11,639	K613_0690	MR200/180	182/184TC	AW200/014	68.772	3,390	4.07	11,639	3.26	11,639	2.44	11,639
4.92	11,639	K613_0690	MR250/210	213/215TC	AW250/102	68.772	3,390	4.07	11,639	3.26	11,639	2.44	11,639
5.27	11,554	K613_0640	MR160/050	56C	AW160/012	63.710	3,325	4.65	12,301	3.88	12,844	2.91	12,844
5.27	11,554	K613_0640	MR160/140	143/145TC	AW160/012	63.710	3,325	4.65	12,301	3.88	12,844	2.91	12,844
5.86	12,844	K613_0640	MR200/180	182/184TC	AW200/014	63.710	3,325	4.85	12,844	3.88	12,844	2.91	12,844
5.86	12,844	K613_0640	MR250/210	213/215TC	AW250/102	63.710	3,325	4.85	12,844	3.88	12,844	2.91	12,844
7.85	19,244	K713_0710	MR200/180	182/184TC	AW200/014	71.203	4,701	6.51	19,244	5.21	19,244	3.90	19,244
7.85	19,244	K713_0710	MR250/210	213/215TC	AW250/102	71.203	4,701	6.51	19,244	5.21	19,244	3.90	19,244
9.53	21,259	K713_0650	MR200/180	182/184TC	AW200/014	64.846	4,593	7.89	21,259	6.31	21,259	4.74	21,259
9.53	21,259	K713_0650	MR250/210	213/215TC	AW250/102	64.846	4,593	7.89	21,259	6.31	21,259	4.74	21,259
9.53	21,259	K713_0650	MR300/250	254/256TC	AW300/110	64.846	4,593	7.89	21,259	6.31	21,259	4.74	21,259
12.55	28,262	K813_0650	MR200/180	182/184TC	AW200/014	65.412	6,067	11.07	30,091	9.54	32,414	7.88	35,677
16.42	37,204	K814_0670	MR250/210	213/215TC	AW250/102	66.833	6,100	13.61	37,204	10.88	37,204	8.16	37,204
16.53	37,204	K813_0650	MR250/180	182/184TC	AW250/102	65.412	6,067	13.69	37,204	10.95	37,204	8.22	37,204
16.53	37,204	K813_0650	MR300/210	213/215TC	AW300/110	65.412	6,067	13.69	37,204	10.95	37,204	8.22	37,204
26.76	58,091	K913_0630	MR250/180	182/184TC	AW250/102	63.071	13,476	23.61	61,849	18.93	62,006	14.20	62,006
28.56	62,006	K913_0630	MR300/180	182/184TC	AW300/110	63.071	13,476	23.67	62,006	18.93	62,006	14.20	62,006
50.18	106,296	K1013_0620	MR300/210	213/215TC	AW300/110	61.553	16,485	41.57	106,296	33.26	106,296	24.94	106,296
50.18	106,296	K1013_0620	MR350/320	324/326TC	AW350/202	61.553	16,485	41.57	106,296	33.26	106,296	24.94	106,296
<b>23 RPM Output (Approximate) Continued Next Page</b>													
0.65	1,772	K203_0800	MR140/050	56C	AW140/010	79.615	1,319	0.54	1,772	0.43	1,772	0.32	1,772
1.07	2,916	K403_0790	MR140/050	56C	AW140/010	79.105	2,457	0.89	2,916	0.71	2,916	0.53	2,916
1.07	2,928	K303_0790	MR140/050	56C	AW140/010	79.424	1,537	0.89	2,928	0.71	2,928	0.53	2,928
1.15	3,100	K303_0780	MR160/050	56C	AW160/012	78.410	1,532	0.95	3,100	0.76	3,100	0.57	3,100

### Part No. Explanation

**K 4 0 2 V G 0690 AW 160 / 012**

K: Right Angle Helical/Bevel  
 4: Unit No.  
 0: Generation No.  
 2: No. of Gear Reductions  
 V: Output Style (A-hollow; V-solid)  
 G: Housing Style  
 0690: Ratio (0690 = 69.0:1)  
 AW: Input Shaft  
 160: Flange No.  
 012: Shaft Dia. (1/16 in.; example - 012 = 12/16 or 3/4)

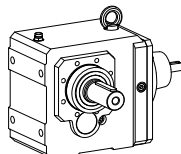

**K 4 0 2 V G 0690 MR 160 / 140**

K: Right Angle Helical/Bevel  
 4: Unit No.  
 0: Generation No.  
 2: No. of Reductions  
 V: Output Style (A-hollow; V-solid)  
 G: Housing Style  
 0690: Ratio (0690 = 69.0:1)  
 MR: Motor Adapter  
 160: Flange No.  
 140: Motor Frame Size (140=143/145TC)

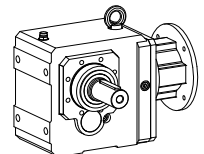

**Mounting position must be specified when ordering.**



# "K" Series – Right Angle Helical/Bevel MGS Reducer – Selection Data



### Selection Procedure:

- Under the Input RPM heading, find **Approximate Output RPM** nearest the requirement.
- In the **Input HP** column locate the rating that is greater than or equal to the required HP.  
(If selection is based on Torque instead of HP, find an **Output Torque** that is equal to or greater than required.)
- When HP or Torque rating is located, read across that row to select the **Base Module**, **Input Option** and **Overhung Loads**.
- If exact **Output RPM** is required, divide the **Input RPM** by the **Exact Ratio**.

1750 RPM Input		Base Module <sup>1)</sup>	Input Options <sup>2)</sup>			Exact Ratio	Overhung Load Output Shaft <sup>3)</sup> lbs.	1450 RPM Input		1160 RPM Input		870 RPM Input	
Input HP	Output Torque in. lbs.		Motor Adapter	NEMA C-Frame Size <sup>4)</sup>	Input Shaft			Input HP	Output Torque in. lbs.	Input HP	Output Torque in. lbs.	Input HP	Output Torque in. lbs.

23 RPM Output (Approximate) Continued							18 RPM		15 RPM		10 RPM		
1.81	4,872	K403_0780	MR160/140	143/145TC	AW160/012	78.095	2,449	1.50	4,872	1.20	4,872	0.90	4,872
2.99	7,972	K513_0780	MR160/050	56C	AW160/012	77.592	2,937	2.47	7,972	1.98	7,972	1.48	7,972
2.99	7,972	K513_0780	MR160/140	143/145TC	AW160/012	77.592	2,937	2.47	7,972	1.98	7,972	1.48	7,972
4.60	12,061	K613_0760	MR160/050	56C	AW160/012	76.140	3,477	4.06	12,841	3.25	12,844	2.44	12,844
4.60	12,061	K613_0760	MR160/140	143/145TC	AW160/012	76.140	3,477	4.06	12,841	3.25	12,844	2.44	12,844
4.90	12,844	K613_0760	MR200/180	182/184TC	AW200/014	76.140	3,477	4.06	12,844	3.25	12,844	2.44	12,844
4.90	12,844	K613_0760	MR250/210	213/215TC	AW250/102	76.140	3,477	4.06	12,844	3.25	12,844	2.44	12,844
7.84	21,259	K713_0790	MR200/180	182/184TC	AW200/014	78.832	4,823	6.49	21,259	5.19	21,259	3.90	21,259
7.84	21,259	K713_0790	MR250/210	213/215TC	AW250/102	78.832	4,823	6.49	21,259	5.19	21,259	3.90	21,259
10.61	26,191	K813_0720	MR200/180	182/184TC	AW200/014	71.701	6,208	9.36	27,886	8.07	30,039	6.43	31,935
10.61	28,998	K813_0790	MR200/180	182/184TC	AW200/014	79.384	6,368	9.36	30,874	8.07	33,258	6.43	35,365
12.94	31,935	K813_0720	MR250/180	182/184TC	AW250/102	71.701	6,208	10.72	31,935	8.58	31,935	6.43	31,935
12.94	31,935	K813_0720	MR300/280	284/286TC	AW300/110	71.701	6,208	10.72	31,935	8.58	31,935	6.43	31,935
12.94	35,365	K813_0790	MR250/180	182/184TC	AW250/102	79.384	6,368	10.73	35,365	8.58	35,365	6.43	35,365
12.94	35,365	K813_0790	MR300/210	213/215TC	AW300/110	79.384	6,368	10.73	35,365	8.58	35,365	6.43	35,365
14.83	37,204	K814_0740	MR250/180	182/184TC	AW250/102	73.993	6,257	12.29	37,204	9.83	37,204	7.37	37,204
23.06	59,535	K913_0750	MR250/180	182/184TC	AW250/102	75.004	14,072	19.90	62,006	15.92	62,006	11.94	62,006
24.02	62,006	K913_0750	MR300/250	254/256TC	AW300/110	75.004	14,072	19.90	62,006	15.92	62,006	11.94	62,006
38.76	100,417	K1013_0750	MR300/250	254/256TC	AW300/110	75.276	17,335	32.11	100,417	25.69	100,417	19.27	100,417

20 RPM Output (Approximate)							17 RPM		13 RPM		9.5 RPM		
2.03	6,105	K513_0870	MR160/050	56C	AW160/012	87.290	3,024	1.68	6,105	1.35	6,105	1.01	6,105
2.03	6,105	K513_0870	MR160/140	143/145TC	AW160/012	87.290	3,024	1.68	6,105	1.35	6,105	1.01	6,105
2.77	7,972	K514_0850	MR160/050	56C	AW160/012	85.034	3,005	2.29	7,972	1.83	7,972	1.37	7,972
2.77	7,972	K514_0850	MR160/140	143/145TC	AW160/012	85.034	3,005	2.29	7,972	1.83	7,972	1.37	7,972
2.90	8,600	K613_0860	MR160/050	56C	AW160/012	86.178	3,586	2.40	8,600	1.92	8,600	1.44	8,600
2.90	8,600	K613_0860	MR160/140	143/145TC	AW160/012	86.178	3,586	2.40	8,600	1.92	8,600	1.44	8,600
3.14	8,919	K614_0840	MR160/050	56C	AW160/012	83.843	3,562	2.60	8,919	2.08	8,919	1.56	8,919
3.14	8,919	K614_0840	MR160/140	143/145TC	AW160/012	83.843	3,562	2.60	8,919	2.08	8,919	1.56	8,919
4.83	14,803	K713_0890	MR200/180	182/184TC	AW200/014	89.004	4,950	4.00	14,803	3.20	14,803	2.40	14,803
4.83	14,803	K713_0890	MR250/210	213/215TC	AW250/102	89.004	4,950	4.00	14,803	3.20	14,803	2.40	14,803
7.04	21,259	K714_0890	MR200/180	182/184TC	AW200/014	89.061	4,950	5.83	21,259	4.67	21,259	3.50	21,259
8.22	24,838	K813_0880	MR200/180	182/184TC	AW200/014	87.763	6,525	6.81	24,838	5.45	24,838	4.09	24,838
8.22	24,838	K813_0880	MR250/210	213/215TC	AW250/102	87.763	6,525	6.81	24,838	5.45	24,838	4.09	24,838
12.35	37,204	K814_0890	MR250/180	182/184TC	AW250/102	88.885	6,525	10.23	37,204	8.18	37,204	6.14	37,204

19 RPM Output (Approximate) Continued Next Page							15 RPM		12 RPM		9 RPM		
0.57	1,772	K203_0910	MR140/050	56C	AW140/010	90.787	1,350	0.47	1,772	0.38	1,772	0.28	1,772
0.99	3,100	K303_0910	MR140/050	56C	AW140/010	91.226	1,575	0.82	3,100	0.65	3,100	0.49	3,100
1.00	3,100	K303_0900	MR160/050	56C	AW160/012	90.061	1,575	0.83	3,100	0.66	3,100	0.50	3,100
1.07	3,363	K403_0910	MR140/050	56C	AW140/010	91.226	2,520	0.89	3,363	0.71	3,363	0.53	3,363
1.57	4,872	K403_0900	MR160/050	56C	AW160/012	90.061	2,520	1.30	4,872	1.04	4,872	0.78	4,872

\* For thermal HP capacity, see rating below.

Base Module	K1	K2	K3	K4	K5	K6	K7	K8	K9	K10
Thermal Capacity	2.95	5.36	7.38	12.34	14.75	20.12	29.50	40.23	53.64	67.05

NEMA Frame Size  
TEFC 1750 RPM

C-Frame	Motor HP
56C	1/3 - 1 1/2
143/145TC	1, 1 1/2, 2
182/184TC	3, 5
213/215TC	7 1/2, 10
254/256TC	15, 20
284/286TC	25, 30
324/326TC	40, 50
364/365TC	60, 75

### Housing Styles

N – Foot Mounted    F – Round Flange    G – Tapped Holes    GD – Torque Arm Bracket

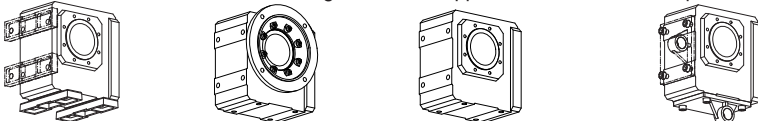

These Housing Styles are available as Hollow (A) or Solid (V) Output.



# "K" Series – Right Angle Helical/Bevel MGS Reducer – Selection Data



- NOTE:** 1) Complete Base Module Part Number by adding Output and Housing Style. Example: K302VG0560.  
 2) Select Input Option and add to completed Part Number. See example below.  
 3) Overhung Load is measured at the center of the shaft extension. Hollow output units are not intended to support overhung loads. If a load rating is required, use 50% of the published overhung load.  
 4) Other frame sizes may also be available. See dimension pages.

1750 RPM Input		Base Module <sup>1)</sup>	Input Options <sup>2)</sup>			Exact Ratio	Overhung Load Output Shaft <sup>3)</sup> lbs.	1450 RPM Input		1160 RPM Input		870 RPM Input	
Input HP	Output Torque in. lbs.		Motor Adapter	NEMA C-Frame Size <sup>4)</sup>	Input Shaft			Input HP	Output Torque in. lbs.	Input HP	Output Torque in. lbs.	Input HP	Output Torque in. lbs.
<b>19 RPM Output (Approximate) Continued</b>													
1.57	4,872	K403_0900	MR160/140	143/145TC	AW160/012	90.061	2,520	1.30	4,872	1.04	4,872	0.78	4,872
2.50	7,972	K514_0940	MR160/050	56C	AW160/012	94.145	3,026	2.07	7,972	1.66	7,972	1.24	7,972
2.50	7,972	K514_0940	MR160/140	143/145TC	AW160/012	94.145	3,026	2.07	7,972	1.66	7,972	1.24	7,972
3.14	9,874	K614_0930	MR160/050	56C	AW160/012	92.826	3,600	2.60	9,874	2.08	9,874	1.56	9,874
3.14	9,874	K614_0930	MR160/140	143/145TC	AW160/012	92.826	3,600	2.60	9,874	2.08	9,874	1.56	9,874
7.97	25,351	K914_0940	MR200/180	182/184/TC	AW200/014	93.777	14,625	6.61	25,351	5.29	25,351	3.96	25,351
17.54	54,901	K914_0920	MR250/180	182/184/TC	AW250/102	92.352	14,625	14.53	54,901	11.62	54,901	8.72	54,901
25.52	82,844	K1013_0940	MR300/250	254/256TC	AW300/110	94.329	18,000	21.14	82,844	16.91	82,844	12.69	82,844
30.25	95,723	K1014_0930	MR300/280	284/286TC	AW300/110	93.343	18,000	25.06	95,723	20.05	95,723	15.04	95,723
<b>18 RPM Output (Approximate)</b>													
2.03	6,761	K513_0970	MR160/050	56C	AW160/012	96.642	3,026	1.68	6,761	1.35	6,761	1.01	6,761
2.03	6,761	K513_0970	MR160/140	143/145TC	AW160/012	96.642	3,026	1.68	6,761	1.35	6,761	1.01	6,761
2.90	9,524	K613_0950	MR160/050	56C	AW160/012	95.412	3,600	2.40	9,524	1.92	9,524	1.44	9,524
2.90	9,524	K613_0950	MR160/140	143/145TC	AW160/012	95.412	3,600	2.40	9,524	1.92	9,524	1.44	9,524
4.83	16,394	K713_0990	MR200/180	182/184/TC	AW200/014	98.540	4,950	4.01	16,394	3.20	16,394	2.40	16,394
4.83	16,394	K713_0990	MR250/210	213/215/TC	AW250/102	98.540	4,950	4.01	16,394	3.20	16,394	2.40	16,394
6.36	21,259	K714_0990	MR200/180	182/184/TC	AW200/014	98.604	4,950	5.27	21,259	4.22	21,259	3.16	21,259
8.22	27,506	K813_0970	MR200/180	182/184/TC	AW200/014	97.166	6,525	6.82	27,506	5.45	27,506	4.09	27,506
8.22	27,506	K813_0970	MR250/210	213/215/TC	AW250/102	97.166	6,525	6.82	27,506	5.45	27,506	4.09	27,506
11.15	37,204	K814_0980	MR250/180	182/184/TC	AW250/102	98.408	6,525	9.24	37,204	7.39	37,204	5.54	37,204
14.50	47,620	K913_0950	MR250/180	182/184/TC	AW250/102	95.412	14,625	12.02	47,620	9.61	47,620	7.21	47,620
14.50	47,620	K913_0950	MR300/250	254/256TC	AW300/110	95.412	14,625	12.02	47,620	9.61	47,620	7.21	47,620
<b>16 RPM Output (Approximate)</b>													
0.47	1,772	K203_1090	MR140/050	56C	AW140/010	109.471	1,350	0.39	1,772	0.31	1,772	0.23	1,772
0.82	3,100	K303_1090	MR140/050	56C	AW140/010	109.208	1,575	0.68	3,100	0.55	3,100	0.41	3,100
0.84	3,100	K303_1080	MR160/050	56C	AW160/012	107.814	1,575	0.69	3,100	0.55	3,100	0.42	3,100
1.07	4,010	K403_1090	MR140/050	56C	AW140/010	108.769	2,520	0.89	4,010	0.71	4,010	0.53	4,010
1.32	4,872	K403_1070	MR160/050	56C	AW160/012	107.381	2,520	1.09	4,872	0.87	4,872	0.66	4,872
1.32	4,872	K403_1070	MR160/140	143/145TC	AW160/012	107.381	2,520	1.09	4,872	0.87	4,872	0.66	4,872
2.08	7,972	K514_1130	MR160/050	56C	AW160/012	112.834	3,026	1.73	7,972	1.38	7,972	1.04	7,972
2.08	7,972	K514_1130	MR160/140	143/145TC	AW160/012	112.834	3,026	1.73	7,972	1.38	7,972	1.04	7,972
2.98	11,257	K614_1110	MR160/050	56C	AW160/012	111.254	3,600	2.47	11,257	1.98	11,257	1.48	11,257
2.98	11,257	K614_1110	MR160/140	143/145TC	AW160/012	111.254	3,600	2.47	11,257	1.98	11,257	1.48	11,257
3.08	11,841	K714_1130	MR160/050	56C	AW160/012	113.236	4,950	2.56	11,841	2.04	11,841	1.53	11,841
3.08	11,841	K714_1130	MR160/140	143/145TC	AW160/012	113.236	4,950	2.56	11,841	2.04	11,841	1.53	11,841
5.47	21,259	K714_1150	MR200/180	182/184/TC	AW200/014	114.700	4,950	4.53	21,259	3.62	21,259	2.72	21,259
7.97	30,964	K814_1150	MR200/180	182/184/TC	AW200/014	114.579	6,525	6.60	30,964	5.28	30,964	3.96	30,964
9.73	37,204	K814_1130	MR250/210	213/215/TC	AW250/102	112.838	6,525	8.06	37,204	6.45	37,204	4.83	37,204

### Part No. Explanation

**K 4 0 2 V G 0690 AW 160 /012**

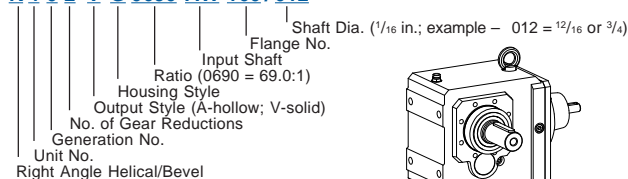

**K 4 0 2 V G 0690 MR 160 /140**

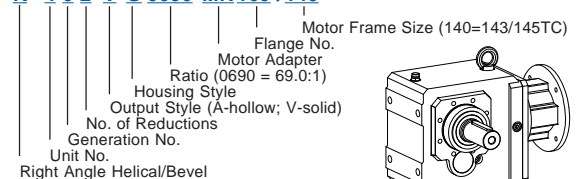

**Mounting position must be specified when ordering.**





# "K" Series – Right Angle Helical/Bevel MGS Reducer – Selection Data



### Selection Procedure:

- Under the Input RPM heading, find **Approximate Output RPM** nearest the requirement.
- In the **Input HP** column locate the rating that is greater than or equal to the required HP.  
(If selection is based on Torque instead of HP, find an **Output Torque** that is equal to or greater than required.)
- When HP or Torque rating is located, read across that row to select the **Base Module**, **Input Option** and **Overhung Loads**.
- If exact **Output RPM** is required, divide the **Input RPM** by the **Exact Ratio**.

1750 RPM Input		Base Module <sup>1)</sup>	Input Options <sup>2)</sup>			Exact Ratio	Overhung Load Output Shaft <sup>3)</sup> lbs.	1450 RPM Input		1160 RPM Input		870 RPM Input	
Input HP	Output Torque in. lbs.		Motor Adapter	NEMA C-Frame Size <sup>4)</sup>	Input Shaft			Input HP	Output Torque in. lbs.	Input HP	Output Torque in. lbs.	Input HP	Output Torque in. lbs.
<b>14 RPM Output (Approximate)</b>													
1.88	7,972	K514_1250	MR160/050	56C	AW160/012	124.924	3,026	1.56	7,972	1.25	7,972	0.94	7,972
1.88	7,972	K514_1250	MR160/140	143/145TC	AW160/012	124.924	3,026	1.56	7,972	1.25	7,972	0.94	7,972
2.98	12,464	K614_1230	MR160/050	56C	AW160/012	123.174	3,600	2.47	12,464	1.98	12,464	1.48	12,464
2.98	12,464	K614_1230	MR160/140	143/145TC	AW160/012	123.174	3,600	2.47	12,464	1.98	12,464	1.48	12,464
3.08	13,110	K714_1250	MR160/050	56C	AW160/012	125.368	4,950	2.56	13,110	2.04	13,110	1.53	13,110
3.08	13,110	K714_1250	MR160/140	143/145TC	AW160/012	125.368	4,950	2.56	13,110	2.04	13,110	1.53	13,110
4.94	21,259	K714_1270	MR200/180	182/184TC	AW200/014	126.990	4,950	4.09	21,259	3.27	21,259	2.45	21,259
7.97	34,290	K814_1270	MR200/180	182/184TC	AW200/014	126.855	6,525	6.61	34,290	5.29	34,290	3.96	34,290
7.98	34,011	K914_1260	MR200/180	182/184TC	AW200/014	125.788	14,625	6.61	34,011	5.29	34,011	3.96	34,011
8.78	37,204	K814_1250	MR250/210	213/215TC	AW250/102	124.927	6,525	7.28	37,204	5.82	37,204	4.37	37,204
14.76	62,006	K914_1240	MR250/180	182/184TC	AW250/102	123.877	14,625	12.23	62,006	9.79	62,006	7.34	62,006
17.39	71,713	K1014_1220	MR250/180	182/184TC	AW250/102	121.636	18,000	14.41	71,713	11.53	71,713	8.65	71,713
25.34	106,296	K1014_1240	MR300/210	213/215TC	AW300/110	123.715	18,000	21.00	106,296	16.80	106,296	12.60	106,296

<b>13 RPM Output (Approximate)</b>													
0.38	1,772	K203_1350	MR140/050	56C	AW140/010	135.335	1,350	0.32	1,772	0.25	1,772	0.19	1,772
0.66	3,100	K303_1360	MR140/050	56C	AW140/010	136.029	1,575	0.55	3,100	0.44	3,100	0.33	3,100
0.67	3,100	K303_1340	MR160/050	56C	AW160/012	134.292	1,575	0.56	3,100	0.44	3,100	0.33	3,100
1.04	4,872	K403_1360	MR140/050	56C	AW140/010	136.137	2,520	0.86	4,872	0.69	4,872	0.52	4,872
1.05	4,872	K403_1340	MR160/050	56C	AW160/012	134.399	2,520	0.87	4,872	0.70	4,872	0.52	4,872
1.05	4,872	K403_1340	MR160/140	143/145TC	AW160/012	134.399	2,520	0.87	4,872	0.70	4,872	0.52	4,872
1.75	7,972	K514_1350	MR160/050	56C	AW160/012	134.560	3,026	1.45	7,972	1.16	7,972	0.87	7,972
1.75	7,972	K514_1350	MR160/140	143/145TC	AW160/012	134.560	3,026	1.45	7,972	1.16	7,972	0.87	7,972
2.83	12,844	K614_1340	MR160/050	56C	AW160/012	133.827	3,600	2.35	12,844	1.88	12,844	1.41	12,844
2.83	12,844	K614_1340	MR160/140	143/145TC	AW160/012	133.827	3,600	2.35	12,844	1.88	12,844	1.41	12,844
2.97	13,797	K714_1370	MR160/050	56C	AW160/012	137.025	4,950	2.46	13,797	1.97	13,797	1.48	13,797
2.97	13,797	K714_1370	MR160/140	143/145TC	AW160/012	137.025	4,950	2.46	13,797	1.97	13,797	1.48	13,797
4.52	21,259	K714_1390	MR200/180	182/184TC	AW200/014	138.797	4,950	3.74	21,259	2.99	21,259	2.25	21,259
7.87	37,204	K814_1390	MR250/180	182/184TC	AW250/102	139.387	6,525	6.52	37,204	5.22	37,204	3.91	37,204

<b>12 RPM Output (Approximate)</b>													
1.58	7,972	K514_1490	MR160/050	56C	AW160/012	148.977	3,026	1.31	7,972	1.05	7,972	0.78	7,972
1.58	7,972	K514_1490	MR160/140	143/145TC	AW160/012	148.977	3,026	1.31	7,972	1.05	7,972	0.78	7,972
2.56	12,844	K614_1480	MR160/050	56C	AW160/012	148.165	3,600	2.12	12,844	1.69	12,844	1.27	12,844
2.56	12,844	K614_1480	MR160/140	143/145TC	AW160/012	148.165	3,600	2.12	12,844	1.69	12,844	1.27	12,844
2.97	15,275	K714_1520	MR160/050	56C	AW160/012	151.706	4,950	2.46	15,275	1.97	15,275	1.48	15,275
2.97	15,275	K714_1520	MR160/140	143/145TC	AW160/012	151.706	4,950	2.46	15,275	1.97	15,275	1.48	15,275
6.82	32,748	K814_1420	MR200/180	182/184TC	AW200/014	141.539	6,525	6.02	34,867	5.14	37,204	3.85	37,204
7.97	40,284	K914_1490	MR200/180	182/184TC	AW200/014	148.996	14,625	6.61	40,284	5.29	40,284	3.96	40,284
12.47	62,006	K914_1470	MR250/180	182/184TC	AW250/102	146.732	14,625	10.33	62,006	8.26	62,006	6.20	62,006
15.61	78,797	K1014_1490	MR250/180	182/184TC	AW250/102	148.889	18,000	13.77	83,894	11.03	84,001	8.27	84,001
20.70	106,296	K1014_1510	MR300/210	213/215TC	AW300/110	151.435	18,000	17.16	106,296	13.72	106,296	10.29	106,296

\* For thermal HP capacity, see rating below.

Base Module	K1	K2	K3	K4	K5	K6	K7	K8	K9	K10
Thermal Capacity	2.95	5.36	7.38	12.34	14.75	20.12	29.50	40.23	53.64	67.05

NEMA Frame Size  
TEFC 1750 RPM

C-Frame	Motor HP
56C	1/3 - 1 1/2
143/145TC	1, 1 1/2, 2
182/184TC	3, 5
213/215TC	7 1/2, 10
254/256TC	15, 20
284/286TC	25, 30
324/326TC	40, 50
364/365TC	60, 75

### Housing Styles

N – Foot Mounted    F – Round Flange    G – Tapped Holes    GD – Torque Arm Bracket

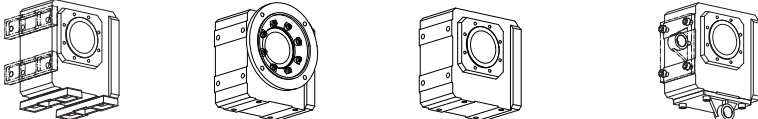

These Housing Styles are available as Hollow (A) or Solid (V) Output.





# "K" Series – Right Angle Helical/Bevel MGS Reducer – Selection Data



- NOTE:** 1) Complete Base Module Part Number by adding Output and Housing Style. Example: K302VG0560.  
 2) Select Input Option and add to completed Part Number. See example below.  
 3) Overhung Load is measured at the center of the shaft extension. Hollow output units are not intended to support overhung loads. If a load rating is required, use 50% of the published overhung load.  
 4) Other frame sizes may also be available. See dimension pages.

1750 RPM Input		Base Module <sup>1)</sup>	Input Options <sup>2)</sup>			Exact Ratio	Overhung Load Output Shaft <sup>3)</sup> lbs.	1450 RPM Input		1160 RPM Input		870 RPM Input							
Input HP	Output Torque in. lbs.		Motor Adapter	NEMA C-Frame Size <sup>4)</sup>	Input Shaft			Input HP	Output Torque in. lbs.	Input HP	Output Torque in. lbs.	Input HP	Output Torque in. lbs.						
<b>11 RPM Output (Approximate)</b>														<b>9 RPM</b>		<b>7.5 RPM</b>		<b>5.5 RPM</b>	
4.08	21,259	K714_1540	MR200/180	182/184/TC	AW200/014	153.668	4,950	3.38	21,259	2.71	21,259	2.03	21,259						
6.83	36,257	K814_1570	MR200/180	182/184/TC	AW200/014	156.703	6,525	5.80	37,204	4.64	37,204	3.48	37,204						
7.11	37,204	K814_1540	MR250/180	182/184/TC	AW250/102	154.322	6,525	5.89	37,204	4.71	37,204	3.54	37,204						
<b>10 RPM Output (Approximate)</b>														<b>8.5 RPM</b>		<b>7 RPM</b>		<b>5 RPM</b>	
0.28	1,772	K203_1810	MR140/050	56C	AW140/010	181.048	1,350	0.24	1,772	0.19	1,772	0.14	1,772						
0.49	3,048	K303_1810	MR140/050	56C	AW140/010	181.048	1,575	0.41	3,048	0.32	3,048	0.24	3,048						
0.50	3,048	K303_1790	MR160/050	56C	AW160/012	178.737	1,575	0.41	3,048	0.33	3,048	0.25	3,048						
0.76	4,737	K403_1810	MR140/050	56C	AW140/010	181.372	2,520	0.63	4,737	0.50	4,737	0.38	4,737						
0.77	4,737	K403_1790	MR160/050	56C	AW160/012	179.056	2,520	0.64	4,737	0.51	4,737	0.38	4,737						
1.40	7,972	K514_1680	MR160/050	56C	AW160/012	168.200	3,026	1.16	7,972	0.93	7,972	0.69	7,972						
1.40	7,972	K514_1680	MR160/140	143/145TC	AW160/012	168.200	3,026	1.16	7,972	0.93	7,972	0.69	7,972						
2.27	12,844	K614_1670	MR160/050	56C	AW160/012	166.694	3,600	1.88	12,844	1.51	12,844	1.13	12,844						
2.27	12,844	K614_1670	MR160/140	143/145TC	AW160/012	166.694	3,600	1.88	12,844	1.51	12,844	1.13	12,844						
2.84	16,753	K714_1740	MR160/050	56C	AW160/012	174.209	4,950	2.35	16,753	1.88	16,753	1.41	16,753						
2.84	16,753	K714_1740	MR160/140	143/145TC	AW160/012	174.209	4,950	2.35	16,753	1.88	16,753	1.41	16,753						
3.55	21,259	K714_1760	MR200/180	182/184/TC	AW200/014	176.462	4,950	2.94	21,259	2.36	21,259	1.77	21,259						
5.95	34,989	K814_1730	MR200/180	182/184/TC	AW200/014	173.313	6,525	5.25	37,204	4.20	37,204	3.15	37,204						
6.43	37,204	K814_1710	MR250/210	213/215/TC	AW250/102	170.679	6,525	5.33	37,204	4.26	37,204	3.20	37,204						
<b>9 RPM Output (Approximate)</b>														<b>7.5 RPM</b>		<b>5.5 RPM</b>		<b>4.5 RPM</b>	
1.26	7,972	K514_1860	MR160/050	56C	AW160/012	186.221	3,026	1.05	7,972	0.84	7,972	0.63	7,972						
1.26	7,972	K514_1860	MR160/140	143/145TC	AW160/012	186.221	3,026	1.05	7,972	0.84	7,972	0.63	7,972						
2.05	12,844	K614_1850	MR160/050	56C	AW160/012	184.554	3,600	1.70	12,844	1.36	12,844	1.02	12,844						
2.05	12,844	K614_1850	MR160/140	143/145TC	AW160/012	184.554	3,600	1.70	12,844	1.36	12,844	1.02	12,844						
2.84	18,548	K714_1930	MR160/050	56C	AW160/012	192.874	4,950	2.35	18,548	1.88	18,548	1.41	18,548						
2.84	18,548	K714_1930	MR160/140	143/145TC	AW160/012	192.874	4,950	2.35	18,548	1.88	18,548	1.41	18,548						
3.21	21,259	K714_1950	MR200/180	182/184/TC	AW200/014	195.368	4,950	2.66	21,259	2.13	21,259	1.60	21,259						
5.72	37,204	K814_1920	MR200/180	182/184/TC	AW200/014	191.882	6,525	4.74	37,204	3.79	37,204	2.84	37,204						
5.81	37,204	K814_1890	MR250/180	182/184/TC	AW250/102	188.966	6,525	4.81	37,204	3.85	37,204	2.89	37,204						
6.82	44,347	K914_1920	MR200/180	182/184/TC	AW200/014	191.670	14,625	6.02	47,216	5.19	50,862	3.90	51,037						
9.69	62,006	K914_1890	MR250/180	182/184/TC	AW250/102	188.757	14,625	8.03	62,006	6.42	62,006	4.82	62,006						
13.17	83,571	K1014_1870	MR250/180	182/184/TC	AW250/102	187.236	18,000	11.61	88,978	10.01	95,848	7.89	100,754						
16.46	106,296	K1014_1900	MR300/210	213/215/TC	AW300/110	190.437	18,000	13.64	106,296	10.91	106,296	8.18	106,296						
<b>8 RPM Output (Approximate) Continued Next Page</b>														<b>6.5 RPM</b>		<b>5.5 RPM</b>		<b>4 RPM</b>	
0.19	1,407	K203_2180	MR140/050	56C	AW140/010	217.538	1,350	0.16	1,407	0.12	1,407	0.09	1,407						
0.31	2,345	K303_2180	MR140/050	56C	AW140/010	218.176	1,575	0.26	2,345	0.21	2,345	0.16	2,345						
0.50	3,752	K403_2180	MR140/050	56C	AW140/010	218.176	2,520	0.41	3,752	0.33	3,752	0.25	3,752						
0.51	3,752	K403_2150	MR160/050	56C	AW160/012	215.391	2,520	0.42	3,752	0.34	3,752	0.25	3,752						
1.04	7,972	K514_2250	MR160/050	56C	AW160/012	225.417	3,026	0.86	7,972	0.69	7,972	0.52	7,972						

### Part No. Explanation

**K 4 0 2 V G 0690 AW 160 /012**

K: Right Angle Helical/Bevel  
 4: Unit No.  
 0: Generation No.  
 2: No. of Gear Reductions  
 V: Output Style (A-hollow; V-solid)  
 G: Housing Style  
 0690: Ratio (0690 = 69.0:1)  
 AW: Input Shaft  
 160: Flange No.  
 012: Shaft Dia. (1/16 in.; example - 012 = 12/16 or 3/4)

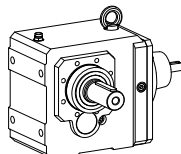

**K 4 0 2 V G 0690 MR 160 /140**

K: Right Angle Helical/Bevel  
 4: Unit No.  
 0: Generation No.  
 2: No. of Reductions  
 V: Output Style (A-hollow; V-solid)  
 G: Housing Style  
 0690: Ratio (0690 = 69.0:1)  
 MR: Motor Adapter  
 160: Flange No.  
 140: Motor Frame Size (140=143/145TC)

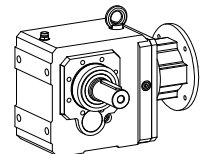

**Mounting position must be specified when ordering.**



# "K" Series – Right Angle Helical/Bevel MGS Reducer – Selection Data



### Selection Procedure:

- Under the Input RPM heading, find **Approximate Output RPM** nearest the requirement.
- In the **Input HP** column locate the rating that is greater than or equal to the required HP.  
(If selection is based on Torque instead of HP, find an **Output Torque** that is equal to or greater than required.)
- When HP or Torque rating is located, read across that row to select the **Base Module**, **Input Option** and **Overhung Loads**.
- If exact **Output RPM** is required, divide the **Input RPM** by the **Exact Ratio**.

1750 RPM Input		Base Module <sup>1)</sup>	Input Options <sup>2)</sup>			Exact Ratio	Overhung Load Output Shaft <sup>3)</sup> lbs.	1450 RPM Input		1160 RPM Input		870 RPM Input	
Input HP	Output Torque in. lbs.		Motor Adapter	NEMA C-Frame Size <sup>4)</sup>	Input Shaft			Input HP	Output Torque in. lbs.	Input HP	Output Torque in. lbs.	Input HP	Output Torque in. lbs.
<b>8 RPM Output (Approximate) Continued</b>													
1.04	7,972	<b>K514_2250</b>	<b>MR160/140</b>	143/145TC	<b>AW160/012</b>	225.417	3,026	0.86	7,972	0.69	7,972	0.52	7,972
1.70	12,844	<b>K614_2230</b>	<b>MR160/050</b>	56C	<b>AW160/012</b>	222.507	3,600	1.41	12,844	1.13	12,844	0.85	12,844
1.70	12,844	<b>K614_2230</b>	<b>MR160/140</b>	143/145TC	<b>AW160/012</b>	222.507	3,600	1.41	12,844	1.13	12,844	0.85	12,844
2.59	19,872	<b>K714_2260</b>	<b>MR160/050</b>	56C	<b>AW160/012</b>	226.472	4,950	2.22	20,589	1.78	20,589	1.33	20,589
2.59	19,872	<b>K714_2260</b>	<b>MR160/140</b>	143/145TC	<b>AW160/012</b>	226.472	4,950	2.22	20,589	1.78	20,589	1.33	20,589
4.74	37,204	<b>K814_2310</b>	<b>MR200/180</b>	182/184/TC	<b>AW200/014</b>	231.404	6,525	3.93	37,204	3.14	37,204	2.36	37,204
4.82	37,204	<b>K814_2280</b>	<b>MR250/180</b>	182/184/TC	<b>AW250/102</b>	227.887	6,525	3.99	37,204	3.19	37,204	2.39	37,204
<b>7 RPM Output (Approximate)</b>													
0.94	7,972	<b>K514_2500</b>	<b>MR160/050</b>	56C	<b>AW160/012</b>	249.569	3,026	0.78	7,972	0.62	7,972	0.47	7,972
1.29	11,639	<b>K614_2660</b>	<b>MR160/050</b>	56C	<b>AW160/012</b>	265.917	3,600	1.07	11,639	0.86	11,639	0.64	11,639
1.29	11,639	<b>K614_2660</b>	<b>MR160/140</b>	143/145TC	<b>AW160/012</b>	265.917	3,600	1.07	11,639	0.86	11,639	0.64	11,639
1.54	12,844	<b>K614_2460</b>	<b>MR160/050</b>	56C	<b>AW160/012</b>	246.347	3,600	1.27	12,844	1.02	12,844	0.76	12,844
1.54	12,844	<b>K614_2460</b>	<b>MR160/140</b>	143/145TC	<b>AW160/012</b>	246.347	3,600	1.27	12,844	1.02	12,844	0.76	12,844
2.50	21,259	<b>K714_2510</b>	<b>MR160/050</b>	56C	<b>AW160/012</b>	250.737	4,950	2.07	21,259	1.66	21,259	1.24	21,259
2.50	21,259	<b>K714_2510</b>	<b>MR160/140</b>	143/145TC	<b>AW160/012</b>	250.737	4,950	2.07	21,259	1.66	21,259	1.24	21,259
4.28	37,204	<b>K814_2560</b>	<b>MR200/180</b>	182/184/TC	<b>AW200/014</b>	256.198	6,525	3.55	37,204	2.84	37,204	2.13	37,204
4.35	37,204	<b>K814_2520</b>	<b>MR250/210</b>	213/215/TC	<b>AW250/102</b>	252.304	6,525	3.60	37,204	2.88	37,204	2.16	37,204
5.72	47,896	<b>K914_2470</b>	<b>MR200/180</b>	182/184/TC	<b>AW200/014</b>	247.029	14,625	5.05	50,994	4.35	54,932	3.59	60,460
7.52	62,006	<b>K914_2430</b>	<b>MR250/180</b>	182/184/TC	<b>AW250/102</b>	243.275	14,625	6.23	62,006	4.98	62,006	3.74	62,006
11.16	89,859	<b>K1014_2370</b>	<b>MR250/180</b>	182/184/TC	<b>AW250/102</b>	237.418	18,000	9.85	95,672	8.49	103,060	6.56	106,296
<b>6 RPM Output (Approximate)</b>													
0.13	1,172	<b>K203_2720</b>	<b>MR140/050</b>	56C	<b>AW140/010</b>	271.923	1,350	0.10	1,172	0.08	1,172	0.06	1,172
0.20	1,876	<b>K303_2720</b>	<b>MR140/050</b>	56C	<b>AW140/010</b>	271.923	1,575	0.17	1,876	0.13	1,876	0.10	1,876
0.35	3,283	<b>K403_2720</b>	<b>MR140/050</b>	56C	<b>AW140/010</b>	271.572	2,520	0.29	3,283	0.23	3,283	0.17	3,283
0.78	7,972	<b>K514_3000</b>	<b>MR160/050</b>	56C	<b>AW160/012</b>	300.023	3,026	0.65	7,972	0.52	7,972	0.39	7,972
0.79	7,268	<b>K514_2710</b>	<b>MR160/050</b>	56C	<b>AW160/012</b>	270.989	3,026	0.66	7,268	0.52	7,268	0.39	7,268
1.29	12,844	<b>K614_2940</b>	<b>MR160/050</b>	56C	<b>AW160/012</b>	294.408	3,600	1.07	12,844	0.85	12,844	0.64	12,844
2.06	21,259	<b>K714_3050</b>	<b>MR160/050</b>	56C	<b>AW160/012</b>	304.817	4,950	1.70	21,259	1.36	21,259	1.02	21,259
2.06	21,259	<b>K714_3050</b>	<b>MR160/140</b>	143/145TC	<b>AW160/012</b>	304.817	4,950	1.70	21,259	1.36	21,259	1.02	21,259
2.06	19,244	<b>K714_2750</b>	<b>MR160/050</b>	56C	<b>AW160/012</b>	275.319	4,950	1.71	19,244	1.37	19,244	1.03	19,244
2.06	19,244	<b>K714_2750</b>	<b>MR160/140</b>	143/145TC	<b>AW160/012</b>	275.319	4,950	1.71	19,244	1.37	19,244	1.03	19,244
3.35	31,935	<b>K814_2810</b>	<b>MR200/180</b>	182/184/TC	<b>AW200/014</b>	280.830	6,525	2.78	31,935	2.22	31,935	1.67	31,935
3.35	35,365	<b>K814_3110</b>	<b>MR200/180</b>	182/184/TC	<b>AW200/014</b>	310.919	6,525	2.78	35,365	2.22	35,365	1.67	35,365
3.41	31,935	<b>K814_2770</b>	<b>MR250/210</b>	213/215/TC	<b>AW250/102</b>	276.563	6,525	2.82	31,935	2.26	31,935	1.69	31,935
3.41	35,365	<b>K814_3060</b>	<b>MR250/180</b>	182/184/TC	<b>AW250/102</b>	306.194	6,525	2.82	35,365	2.26	35,365	1.69	35,365
5.00	49,821	<b>K914_2940</b>	<b>MR200/180</b>	182/184/TC	<b>AW200/014</b>	293.764	14,625	4.41	53,044	3.80	57,140	3.10	62,006
9.53	93,852	<b>K1014_2900</b>	<b>MR250/210</b>	213/215/TC	<b>AW250/102</b>	290.350	18,000	8.41	99,923	6.76	100,417	5.07	100,417

\* For thermal HP capacity, see rating below.

Base Module	K1	K2	K3	K4	K5	K6	K7	K8	K9	K10
Thermal Capacity	2.95	5.36	7.38	12.34	14.75	20.12	29.50	40.23	53.64	67.05

NEMA Frame Size  
TEFC 1750 RPM

C-Frame	Motor HP
56C	1/3 - 1 1/2
143/145TC	1, 1 1/2, 2
182/184TC	3, 5
213/215TC	7 1/2, 10
254/256TC	15, 20
284/286TC	25, 30
324/326TC	40, 50
364/365TC	60, 75

### Housing Styles

**N** – Foot Mounted    **F** – Round Flange    **G** – Tapped Holes    **GD** – Torque Arm Bracket

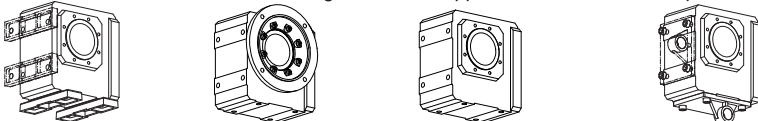

These Housing Styles are available as Hollow (A) or Solid (V) Output.



# "K" Series – Right Angle Helical/Bevel MGS Reducer – Selection Data



- NOTE:** 1) Complete Base Module Part Number by adding Output and Housing Style. Example: K302VG0560.  
 2) Select Input Option and add to completed Part Number. See example below.  
 3) Overhung Load is measured at the center of the shaft extension. Hollow output units are not intended to support overhung loads. If a load rating is required, use 50% of the published overhung load.  
 4) Other frame sizes may also be available. See dimension pages.

1750 RPM Input		Base Module <sup>1)</sup>	Input Options <sup>2)</sup>			Exact Ratio	Overhung Load Output Shaft <sup>3)</sup> lbs.	1450 RPM Input		1160 RPM Input		870 RPM Input	
Input HP	Output Torque in. lbs.		Motor Adapter	NEMA C-Frame Size <sup>4)</sup>	Input Shaft			Input HP	Output Torque in. lbs.	Input HP	Output Torque in. lbs.	Input HP	Output Torque in. lbs.
<b>5 RPM</b>		<b>Output (Approximate)</b>			<b>4.5 RPM</b>		<b>3.5 RPM</b>		<b>2.5 RPM</b>				
0.53	6,105	K514_3380	MR160/050	56C	AW160/012	337.521	3,026	0.44	6,105	0.35	6,105	0.27	6,105
0.53	6,761	K514_3740	MR160/050	56C	AW160/012	373.684	3,026	0.44	6,761	0.35	6,761	0.27	6,761
0.76	8,600	K614_3330	MR160/050	56C	AW160/012	333.223	3,600	0.63	8,600	0.50	8,600	0.38	8,600
0.76	9,524	K614_3690	MR160/050	56C	AW160/012	368.926	3,600	0.63	9,524	0.50	9,524	0.38	9,524
1.27	14,803	K714_3440	MR160/050	56C	AW160/012	344.148	4,950	1.05	14,803	0.84	14,803	0.63	14,803
1.27	14,803	K714_3440	MR160/140	143/145TC	AW160/012	344.148	4,950	1.05	14,803	0.84	14,803	0.63	14,803
1.27	16,394	K714_3810	MR160/050	56C	AW160/012	381.021	4,950	1.05	16,394	0.84	16,394	0.63	16,394
1.27	16,394	K714_3810	MR160/140	143/145TC	AW160/012	381.021	4,950	1.05	16,394	0.84	16,394	0.63	16,394
3.76	47,620	K914_3740	MR200/180	182/184/TC	AW200/014	373.696	14,625	3.11	47,620	2.49	47,620	1.87	47,620

**NOTE: For slower speeds than those shown, units can be combined. Contact STÖBER Drives Inc.**

## Part No. Explanation

**K 4 0 2 V G 0690 AW 160 /012**

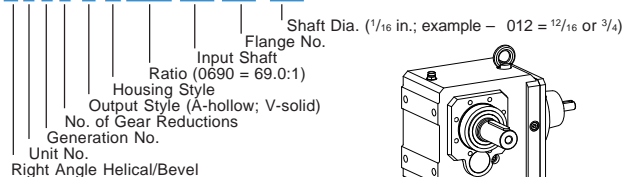

**K 4 0 2 V G 0690 MR 160 /140**

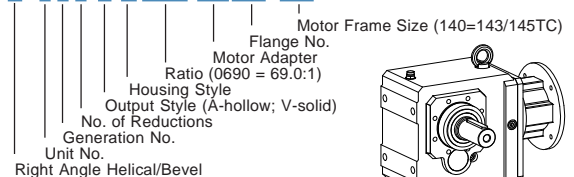

**Mounting position must be specified when ordering.**

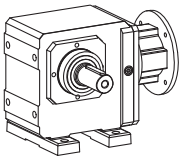

# "K" Series – MGS Reducer Foot Mount – "N" Housing Shaft Output – Dimensional Data

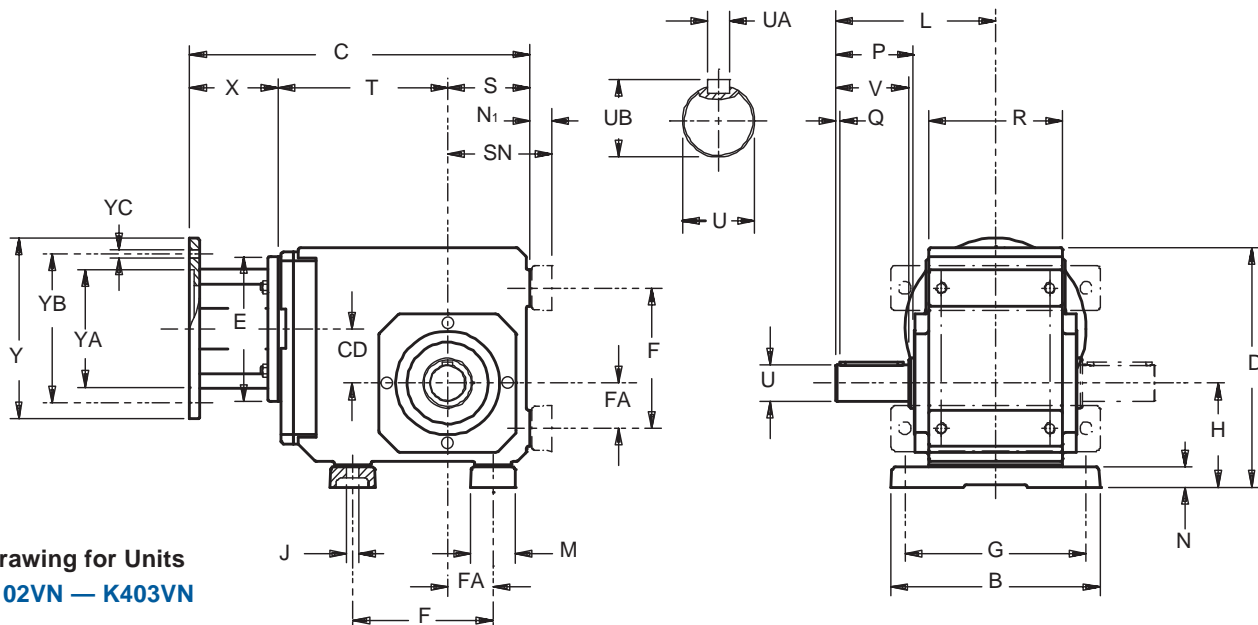

Drawing for Units  
K102VN — K403VN

Table No. 1 "K" Series – Foot Mounting Unit Dimensions (Inches) – "N" Housing Style

Base Module	B	D	F	G	H	J	L	M	N	O	P	Q	R	S	V	Z <sub>1</sub>	BO	FA	N <sub>1</sub>	SN
<b>K102</b>	5.51	6.81	3.54*	4.53	2.95	.35	4.53	1.18	.51	—	2.32	.16	3.54	2.36	1.97	—	—	1.18	.59	2.95
<b>K202/203</b>	7.28	8.39	4.53	6.10	3.46	.43	5.31	1.57	.79	—	2.56	.16	4.53	2.56	2.36	—	—	1.38	.91	3.46
<b>K302/303</b>	7.87	9.29	5.12	6.69	3.86	.43	5.59	1.77	.79	—	2.60	.16	5.12	2.95	2.36	—	—	1.57	.91	3.86
<b>K402/403</b>	9.06	10.43	6.10	7.87	4.53	.55	6.54	1.97	.87	—	3.39	.16	5.83	3.54	2.76	—	—	1.97	.98	4.53
<b>K513/514</b>	9.45	11.42	5.51	7.87	7.48	.71	8.74	2.36	1.06	5.10	3.90	.16	6.30	3.94	3.54	5.98	7.28	1.57	1.18	5.12
<b>K613/614</b>	9.84	13.39	6.30	8.27	8.66	.71	9.29	2.56	1.06	5.35	4.31	.16	6.61	4.72	3.94	6.77	7.87	1.97	1.18	5.91
<b>K713/714</b>	11.42	14.96	7.09	9.45	9.84	.87	10.91	2.76	1.38	6.46	5.14	.16	7.48	4.92	4.72	7.52	8.90	2.17	1.50	6.42
<b>K813/814</b>	14.17	17.91	9.45	11.81	12.20	1.02	12.83	3.35	1.61	7.28	5.94	.20	9.25	5.71	5.51	8.11	11.10	2.95	1.77	7.48
<b>K913/914</b>	16.93	21.46	11.02	14.17	14.37	1.30	15.16	3.74	1.81	8.66	7.13	.31	11.22	7.09	6.69	9.84	12.99	3.74	1.97	9.06
<b>K1013/1014</b>	15.75	23.27	13.78	12.99	14.76	1.54	16.46	4.72	1.77	9.45	8.66	.59	15.75	—	8.27	12.01	14.02	4.53	1.77	8.86

\* Mounting holes are also located on Side 2 (top) of the K1 unit ONLY.

Table No. 2 Motor Adapter Dimensions (Inches)

Motor Adapter	NEMA C-Flange	E	X	Y	YA	YB	YC	Wt. lbs.
<b>MR140/050</b>	56C	5.51	3.31	6.50	4.500	5.87	.41	9
<b>MR160/050</b>	56C	6.30	3.86	6.50	4.500	5.87	.41	16
<b>MR160/140</b>	143/145TC	6.30	3.86	6.50	4.500	5.87	.41	16
<b>MR200/180</b>	182/184TC	7.87	4.80	9.00	8.500	7.25	.55	23
<b>MR250/180</b>	182/184TC	9.84	5.31	9.00	8.500	7.25	.55	36
<b>MR250/210</b>	213/215TC	9.84	5.31	9.00	8.500	7.25	.55	36
<b>MR300/180</b>	182/184TC	11.81	6.50	9.00	8.500	7.25	.57	75
<b>MR300/210</b>	213/215TC	11.81	6.50	9.00	8.500	7.25	.57	75
<b>MR300/250</b>	254/256TC	11.81	6.50	9.00	8.500	7.25	.57	75
<b>MR300/280</b>	284/286TC	11.81	6.50	11.13	10.500	9.00	.57	75
<b>MR350/320</b>	324/326TC	13.78	7.09	13.37	12.500	11.00	.70	133
<b>MR350/360</b>	364/365TC	13.78	7.09	13.37	12.500	11.00	.70	133

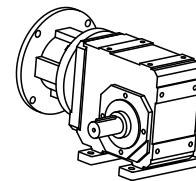

K1 Housing with tapped holes on Side 1, Side 2, and Side 5. Shown with mounting feet on Side 1.

**Part No. Example**

Foot Mounting with Motor Adapter  
**K303VN0650 MR160/140**





# "K" Series – MGS Reducer Foot Mount – "N" Housing Shaft Output – Dimensional Data

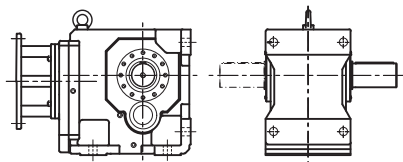
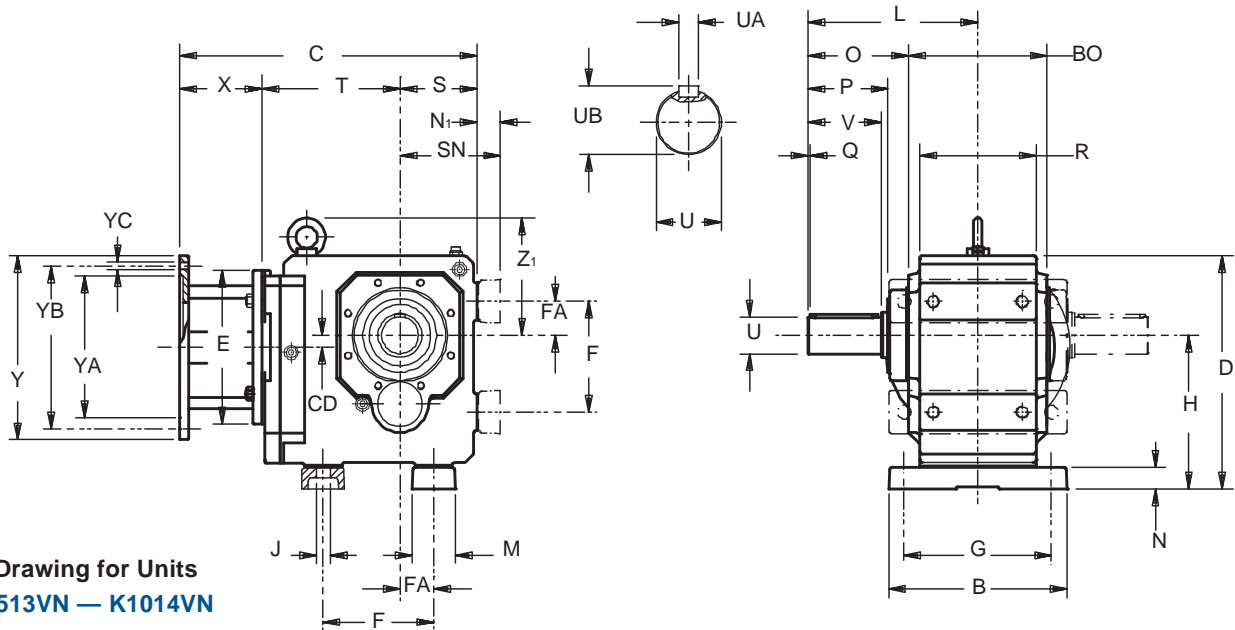
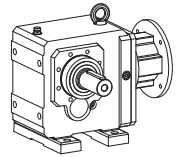

Mounting feet are integral in the K10 housing.

**Table No. 3** Metric output available on request.

Base Module	Standard Shaft – inches			Optional Shaft – mm		
	U	UA – Key	UB	U	UA – Key	UB
<b>K102</b>	1.000	1/4 x 1/4 x 1 9/16	1.11	25 <sub>k6</sub>	M8 x7x40	28
<b>K202/K203</b>	1.250	1/4 x 1/4 x 1 15/16	1.36	30 <sub>k6</sub>	M8 x7x50	33
<b>K302/K303</b>	1.250	1/4 x 1/4 x 1 15/16	1.36	30 <sub>k6</sub>	M8 x7x50	33
<b>K402/K403</b>	1.375	5/16 x 5/16 x 2 5/16	1.51	40 <sub>k6</sub>	M12 x8x70	43
<b>K513/K514</b>	1.750	3/8 x 3/8 x 3 5/32	1.92	45 <sub>k6</sub>	M14 x9x80	48.5
<b>K613/K614</b>	1.750	3/8 x 3/8 x 3 5/32	1.92	50 <sub>k6</sub>	M14 x9x90	53.5
<b>K713/K714</b>	2.375	5/8 x 5/8 x 3 15/16	2.65	60 <sub>k6</sub>	M18 x11x110	64
<b>K813/K814</b>	2.875	3/4 x 3/4 x 4 5/16	3.21	70 <sub>m6</sub>	M20 x12x125	74.5
<b>K913/K914</b>	3.625	7/8 x 7/8 x 5 1/2	4.01	90 <sub>m6</sub>	M25 x14x140	95
<b>K1013/K1014</b>	4.375	1 x 1 x 7 1/8	4.82	110 <sub>m6</sub>	M28 x16x180	116

**Table No. 4** "K" Series – Foot Mounting Unit Dimensions (Inches) – "N" Housing Style

Base Module	MR140/050			MR160/140 <sup>1)</sup>			MR200/180			MR250/210 <sup>2)</sup>			MR300/250 <sup>3)</sup>			MR350/320 <sup>4)</sup>			Wt. lbs.
	CD	C	T	CD	C	T	CD	C	T	CD	C	T	CD	C	T	CD	C	T	
<b>K102</b>	1.42	10.55	4.88	1.42	11.26	5.04	—	—	—	—	—	—	—	—	—	—	—	—	31
<b>K202</b>	1.81	11.50	5.63	1.81	12.21	5.79	1.81	13.23	5.87	—	—	—	—	—	—	—	—	—	40
<b>K203</b>	1.81	12.96	7.09	—	—	—	—	—	—	—	—	—	—	—	—	—	—	—	53
<b>K302</b>	2.07	12.68	6.42	2.07	13.38	6.57	2.07	14.40	6.65	—	—	—	—	—	—	—	—	—	67
<b>K303</b>	2.07	14.13	7.87	.63	15.08	8.27	—	—	—	—	—	—	—	—	—	—	—	—	73
<b>K402</b>	—	—	—	2.36	14.76	7.36	2.36	15.74	7.44	2.36	16.41	7.56	—	—	—	—	—	—	93
<b>K403</b>	2.36	15.51	8.66	.91	16.46	9.06	—	—	—	—	—	—	—	—	—	—	—	—	100
<b>K513</b>	—	—	—	.59	14.57	6.77	.59	15.59	6.85	.59	16.22	6.97	—	—	—	—	—	—	106
<b>K514</b>	—	—	—	.59	16.26	8.46	—	—	—	—	—	—	—	—	—	—	—	—	109
<b>K613</b>	—	—	—	.71	16.10	7.52	.71	17.12	7.60	.71	17.75	7.72	.71	19.49	8.27	—	—	—	170
<b>K614</b>	—	—	—	.71	17.79	9.21	—	—	—	—	—	—	—	—	—	—	—	—	177
<b>K713</b>	—	—	—	—	—	—	.79	18.42	8.70	.79	19.05	8.82	.79	20.75	9.33	—	—	—	221
<b>K714</b>	—	—	—	.79	19.13	10.35	.79	20.86	11.14	—	—	—	—	—	—	—	—	—	234
<b>K813</b>	—	—	—	—	—	—	.94	20.23	9.72	.94	20.82	9.80	.94	22.52	10.31	—	—	—	309
<b>K814</b>	—	—	—	—	—	—	.94	22.64	12.13	—	—	—	—	—	—	—	—	—	331
<b>K913</b>	—	—	—	—	—	—	—	—	—	.98	23.97	11.57	.98	25.68	12.09	.98	27.17	12.99	508
<b>K914</b>	—	—	—	—	—	—	.98	25.79	13.90	.98	26.77	14.37	—	—	—	—	—	—	530
<b>K1013</b>	—	—	—	—	—	—	—	—	—	—	—	—	1.10	15.43	30.79	1.10	32.29	16.34	913
<b>K1014</b>	—	—	—	—	—	—	—	—	—	1.10	31.89	17.72	—	—	—	—	—	—	993

<sup>1)</sup> Also available as **MR160/050** for a NEMA 56C frame motor.  
<sup>2)</sup> Also available as **MR250/180** for a NEMA 182/184TC frame motor.  
<sup>3)</sup> Also available as **MR300/180** for a NEMA 182/184TC, **MR300/210** for a NEMA 213/215TC, and **MR300/280** for a NEMA 284/286TC frame motor.  
<sup>4)</sup> Also available as **MR350/360** for a NEMA 364/365TC frame motor.  
 All weights are approximate.

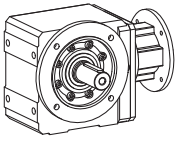

# "K" Series – MGS Reducer Flange Mount – "F" Housing Shaft Output – Dimensional Data

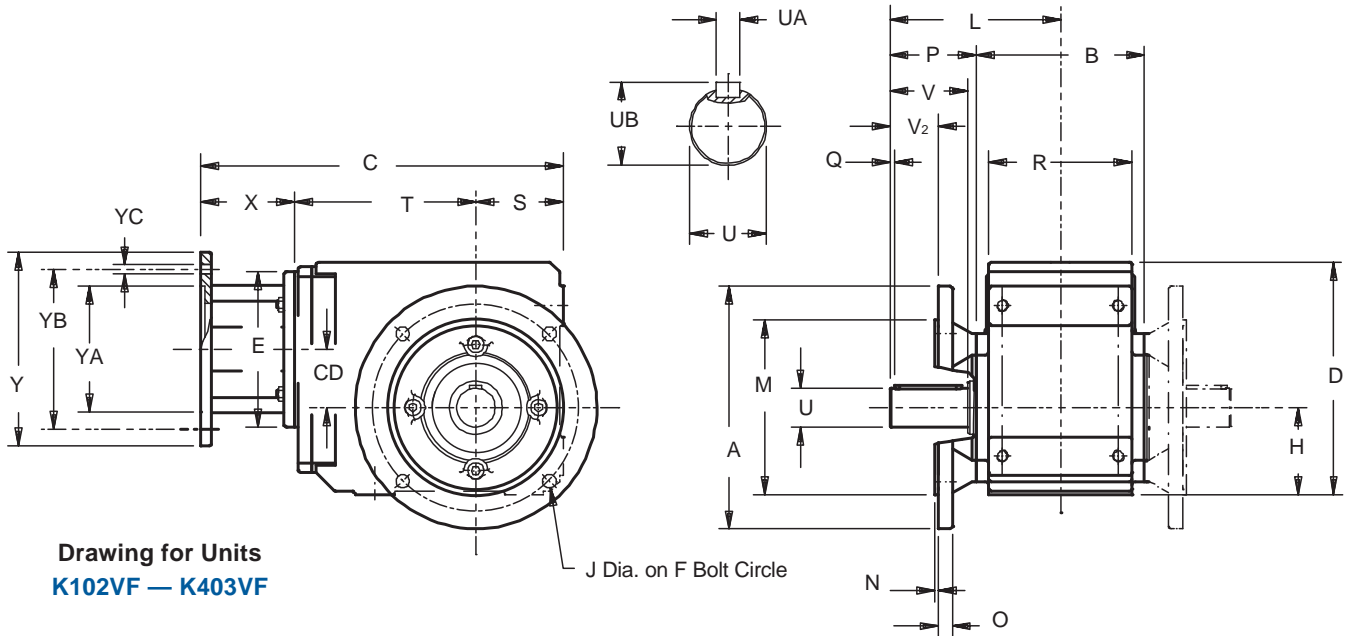

Drawing for Units  
K102VF – K403VF

Table No. 1 "K" Series – Round Flange Unit Dimensions (Inches) – "F" Housing Style

Base Module	A	B	D	F	H	J	L	M	N	O	P	Q	R	S	V	V <sub>2</sub>	Z <sub>1</sub>
K102	6.30	4.17	6.30	5.12	2.36	.35	4.53	4.331 +.001/-0.0004	.14	.39	2.44	.16	3.54	2.36	1.97	1.18	—
K202/203	7.87	5.28	7.48	6.50	2.56	.43	5.31	5.118 +.001/-0.0004	.14	.47	2.68	.16	4.53	2.56	2.36	1.42	—
K302/303	7.87	5.75	8.39	6.50	2.95	.43	5.59	5.118 +.001/-0.0004	.14	.55	2.72	.16	5.12	2.95	2.36	1.22	—
K402/403	9.84	6.81	9.45	8.46	3.54	.55	6.54	7.087 +.001/-0.0004	.16	.59	3.52	.16	5.83	3.54	2.76	1.95	—
K513/514	9.84	7.28	10.24	8.46	6.30	.55	8.74	7.087 +.001/-0.0004	.16	.59	5.10	.16	6.30	3.94	3.54	—	5.98
K613/614	11.81	7.87	12.20	10.43	7.48	.55	9.29	9.055 +.001/-0.001	.16	.67	5.35	.16	6.61	4.72	3.94	—	6.77
K713/714	13.78	8.90	13.46	11.81	8.35	.71	10.91	9.842 +.000/-0.001	.20	.71	6.46	.16	7.48	4.92	4.72	—	7.52
K813/814	15.75	11.10	16.14	13.78	10.43	.71	12.83	11.811 +.000/-0.001	.20	.79	7.28	.20	9.25	5.71	5.51	—	8.11
K913/914	17.72	12.99	19.49	15.75	12.40	.71	15.16	13.780 +.000/-0.001	.20	.91	8.66	.31	11.22	7.09	6.69	—	9.84
K1013/1014	21.65	14.02	23.27	19.69	14.76	.71	18.35	17.716 +.000/-0.002	.20	.98	11.34	.59	15.75	8.86	8.27	—	12.01

Table No. 2 Motor Adapter Dimensions (Inches)

Motor Adapter	NEMA C-Flange	E	X	Y	YA	YB	YC	Wt. lbs.
MR140/050	56C	5.51	3.31	6.50	4.500	5.87	.41	9
MR160/050	56C	6.30	3.86	6.50	4.500	5.87	.41	16
MR160/140	143/145TC	6.30	3.86	6.50	4.500	5.87	.41	16
MR200/180	182/184TC	7.87	4.80	9.00	8.500	7.25	.55	23
MR250/180	182/184TC	9.84	5.31	9.00	8.500	7.25	.55	36
MR250/210	213/215TC	9.84	5.31	9.00	8.500	7.25	.55	36
MR300/180	182/184TC	11.81	6.50	9.00	8.500	7.25	.57	75
MR300/210	213/215TC	11.81	6.50	9.00	8.500	7.25	.57	75
MR300/250	254/256TC	11.81	6.50	9.00	8.500	7.25	.57	75
MR300/280	284/286TC	11.81	6.50	11.13	10.500	9.00	.57	75
MR350/320	324/326TC	13.78	7.09	13.37	12.500	11.00	.70	133
MR350/360	364/365TC	13.78	7.09	13.37	12.500	11.00	.70	133

Table No. 3 "K" Series — Optional Flanges (Inches)

Base Module	Flange Size	A	F	J	L	M	N	O
K102	140	5.512	4.53	.35	3.35	3.740	.12	.39
K202/K203	160	6.300	5.12	.35	3.90	4.331	.14	.47
K302/K303	160	6.300	5.12	.35	4.37	4.331	.14	.55
K713/K714	300	11.811	10.43	.55	6.18	9.055	.20	.71
K813/K814	350	13.780	11.81	.71	7.32	9.843	.20	.79
	450	17.717	15.75	.71	7.32	13.781	.20	.79

Part No. Example  
Round Flange with Motor Adapter  
**K303VF0650 MR160/140**

\* Optional flanges are not available in all sizes.



# "K" Series – MGS Reducer Flange Mount – "F" Housing Shaft Output – Dimensional Data

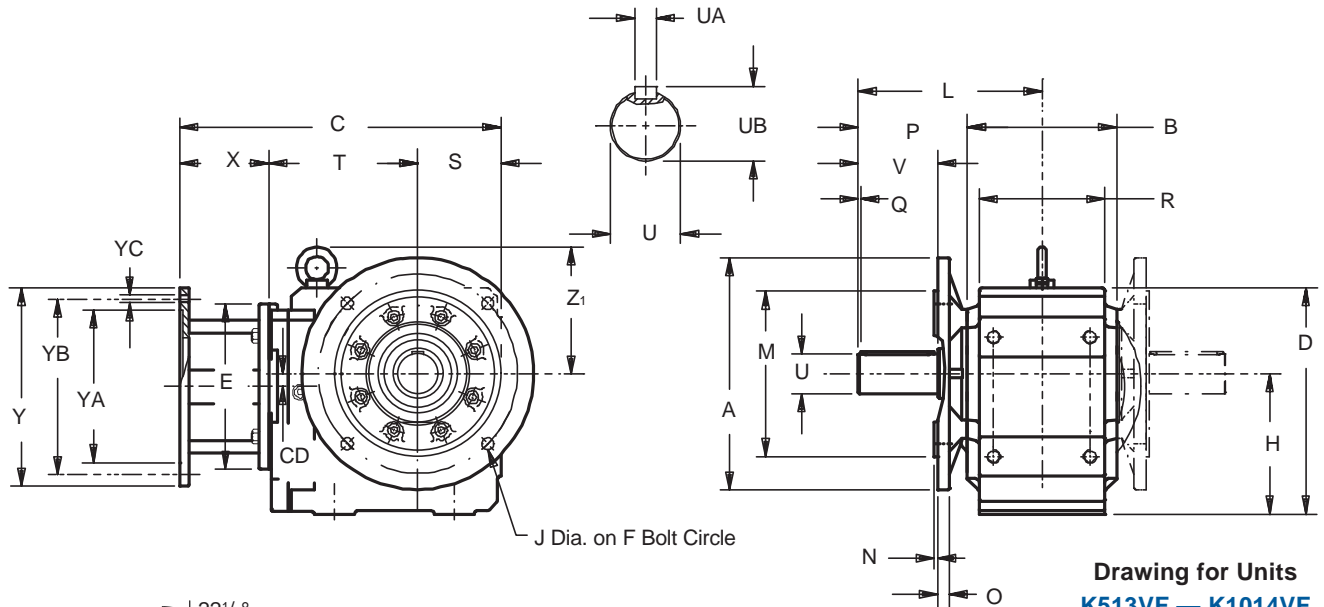
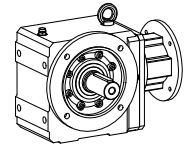
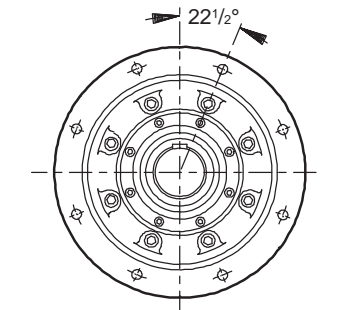

Table No. 4

Metric output available on request.

Base Module	Standard Shaft – inches			Optional Shaft – mm		
	U	UA – Key	UB	U	UA – Key	UB
<b>K102</b>	1.000	1/4 x 1/4 x 1 <sup>9</sup> / <sub>16</sub>	1.11	25 <sub>k6</sub>	M8 x7x40	28
<b>K202/203</b>	1.250	1/4 x 1/4 x 1 <sup>15</sup> / <sub>16</sub>	1.36	30 <sub>k6</sub>	M8 x7x50	33
<b>K302/303</b>	1.250	1/4 x 1/4 x 1 <sup>15</sup> / <sub>16</sub>	1.36	30 <sub>k6</sub>	M8 x7x50	33
<b>K402/403</b>	1.375	5/16 x 5/16 x 2 <sup>5</sup> / <sub>16</sub>	1.51	40 <sub>k6</sub>	M12 x8x70	43
<b>K513/514</b>	1.750	3/8 x 3/8 x 3 <sup>5</sup> / <sub>32</sub>	1.92	45 <sub>k6</sub>	M14 x9x80	48.5
<b>K613/614</b>	1.750	3/8 x 3/8 x 3 <sup>5</sup> / <sub>32</sub>	1.92	50 <sub>k6</sub>	M14 x9x90	53.5
<b>K713/714</b>	2.375	5/8 x 5/8 x 3 <sup>15</sup> / <sub>16</sub>	2.65	60 <sub>k6</sub>	M18 x11x110	64
<b>K813/814</b>	2.875	3/4 x 3/4 x 4 <sup>5</sup> / <sub>16</sub>	3.21	70 <sub>m6</sub>	M20 x12x125	74.5
<b>K913/914</b>	3.625	7/8 x 7/8 x 5 <sup>1</sup> / <sub>2</sub>	4.01	90 <sub>m6</sub>	M25 x14x140	95
<b>K1013/1014</b>	4.375	1 x 1 x 7 <sup>1</sup> / <sub>8</sub>	4.82	110 <sub>m6</sub>	M28 x16x180	116



K913 thru K1014 has 8 mounting holes in the output flange located as shown.

Table No. 5 "K" Series – Flange Mounting Unit Dimensions (Inches) – "F" Housing Style

Base	MR140/050			MR160/140 <sup>1)</sup>			MR200/180			MR250/210 <sup>2)</sup>			MR300/250 <sup>3)</sup>			MR350/320 <sup>4)</sup>			Wt.
Module	CD	C	T	CD	C	T	CD	C	T	CD	C	T	CD	C	T	CD	C	T	lbs.
<b>K102</b>	1.42	10.55	4.88	1.42	11.26	5.04	—	—	—	—	—	—	—	—	—	—	—	—	31
<b>K202</b>	1.81	11.50	5.63	1.81	12.21	5.79	1.81	13.23	5.87	—	—	—	—	—	—	—	—	—	40
<b>K203</b>	1.81	12.96	7.09	—	—	—	—	—	—	—	—	—	—	—	—	—	—	—	53
<b>K302</b>	2.07	12.68	6.42	2.07	13.38	6.57	2.07	14.40	6.65	—	—	—	—	—	—	—	—	—	67
<b>K303</b>	2.07	14.13	7.87	.63	15.08	8.27	—	—	—	—	—	—	—	—	—	—	—	—	73
<b>K402</b>	—	—	—	2.36	14.76	7.36	2.36	15.74	7.44	2.36	16.41	7.56	—	—	—	—	—	—	93
<b>K403</b>	2.36	15.51	8.66	.91	16.46	9.06	—	—	—	—	—	—	—	—	—	—	—	—	100
<b>K513</b>	—	—	—	.59	14.57	6.77	.59	15.59	6.85	.59	16.22	6.97	—	—	—	—	—	—	106
<b>K514</b>	—	—	—	.59	16.26	8.46	—	—	—	—	—	—	—	—	—	—	—	—	109
<b>K613</b>	—	—	—	.71	16.10	7.52	.71	17.12	7.60	.71	17.75	7.72	.71	19.49	8.27	—	—	—	170
<b>K614</b>	—	—	—	.71	17.79	9.21	—	—	—	—	—	—	—	—	—	—	—	—	177
<b>K713</b>	—	—	—	—	—	—	.79	18.42	8.70	.79	19.05	8.82	.79	20.75	9.33	—	—	—	221
<b>K714</b>	—	—	—	.79	19.13	10.35	.79	20.86	11.14	—	—	—	—	—	—	—	—	—	234
<b>K813</b>	—	—	—	—	—	—	.94	20.23	9.72	.94	20.82	9.80	.94	22.52	10.31	—	—	—	309
<b>K814</b>	—	—	—	—	—	—	.94	22.64	12.13	—	—	—	—	—	—	—	—	—	331
<b>K913</b>	—	—	—	—	—	—	—	—	—	.98	23.97	11.57	.98	25.68	12.09	.98	27.17	12.99	508
<b>K914</b>	—	—	—	—	—	—	.98	25.79	13.90	.98	26.77	14.37	—	—	—	—	—	—	530
<b>K1013</b>	—	—	—	—	—	—	—	—	—	—	—	—	1.10	15.43	30.79	1.10	32.29	16.34	913
<b>K1014</b>	—	—	—	—	—	—	—	—	—	1.10	31.89	17.72	—	—	—	—	—	—	993

<sup>1)</sup> Also available as **MR160/050** for a NEMA 56C frame motor.

<sup>2)</sup> Also available as **MR250/180** for a NEMA 182/184TC frame motor.

<sup>3)</sup> Also available as **MR300/180** for a NEMA 182/184TC, **MR300/210** for a NEMA 213/215TC, and **MR300/280** for a NEMA 284/286TC frame motor.

<sup>4)</sup> Also available as **MR350/360** for a NEMA 364/365TC frame motor.

All weights are approximate.







# "K" Series – MGS Reducer Flange Mount – "F" Housing Hollow Output – Dimensional Data

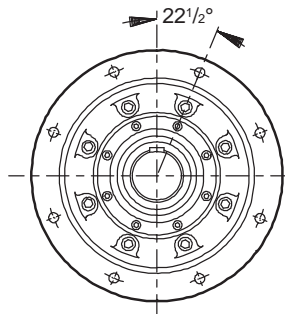
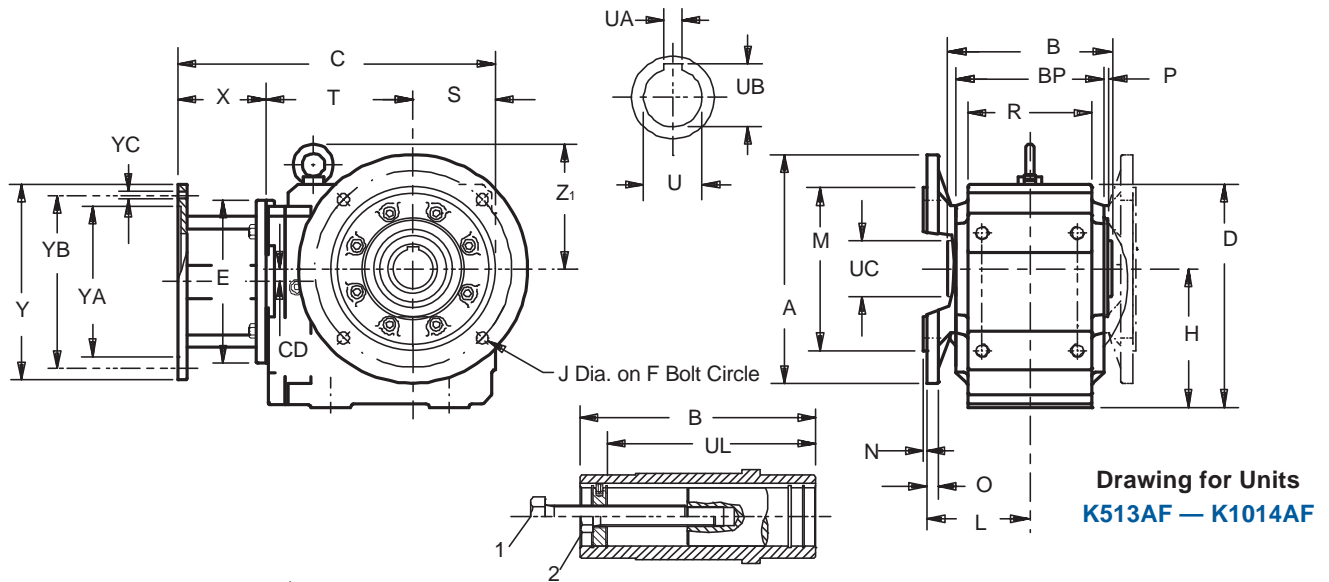
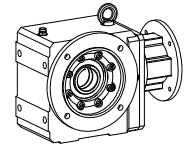

K913 thru K1014 has 8 mounting holes in the output flange located as shown.

**Table No. 4 Metric output available on request.**

Base Module	Standard Bore - inches			Optional Bore - mm		
	U	UA	UB	U	UA	UB
<b>K102</b>	1.000	.250	1.11	25 <sup>H7</sup>	8 <sub>JS9</sub>	28.3
<b>K202/203</b>	1.1875	.250	1.31	30 <sup>H7</sup>	8 <sub>JS9</sub>	33.3
<b>K302/303</b>	1.375	.312	1.52	35 <sup>H7</sup>	10 <sub>JS9</sub>	38.3
<b>K402/403</b>	1.500	.375	1.67	40 <sup>H7</sup>	12 <sub>JS9</sub>	43.3
<b>K513/514</b>	2.000	.500	2.13	50 <sup>H7</sup>	14 <sub>JS9</sub>	53.8
<b>K613/614</b>	2.000	.500	2.23	50 <sup>H7</sup>	14 <sub>JS9</sub>	53.8
<b>K713/714</b>	2.375	.625	2.66	60 <sup>H7</sup>	18 <sub>JS9</sub>	64.4
<b>K813/814</b>	2.750	.625	3.03	70 <sup>H7</sup>	20 <sub>JS9</sub>	74.9
<b>K913/914</b>	3.250	.750	3.59	90 <sup>H7</sup>	25 <sub>JS9</sub>	95.4
<b>K1013/1014</b>	4.000	1.000	4.31	100 <sup>H7</sup>	28 <sub>JS9</sub>	116

**Table No. 5 "K" Series – Hollow Output, Round Flange Unit Dimensions (Inches) – "F" Housing Style**

Base Module	MR140/050			MR160/140 <sup>1)</sup>			MR200/180			MR250/210 <sup>2)</sup>			MR300/250 <sup>3)</sup>			MR350/320 <sup>4)</sup>			Wt. lbs.
	CD	C	T	CD	C	T	CD	C	T	CD	C	T	CD	C	T	CD	C	T	
<b>K102</b>	1.42	10.55	4.88	1.42	11.26	5.04	—	—	—	—	—	—	—	—	—	—	—	—	31
<b>K202</b>	1.81	11.50	5.63	1.81	12.21	5.79	1.81	13.23	5.87	—	—	—	—	—	—	—	—	—	40
<b>K203</b>	1.81	12.96	7.09	—	—	—	—	—	—	—	—	—	—	—	—	—	—	—	53
<b>K302</b>	2.07	12.68	6.42	2.07	13.38	6.57	2.07	14.40	6.65	—	—	—	—	—	—	—	—	—	67
<b>K303</b>	2.07	14.13	7.87	.63	15.08	8.27	—	—	—	—	—	—	—	—	—	—	—	—	73
<b>K402</b>	—	—	—	2.36	14.76	7.36	2.36	15.74	7.44	2.36	16.41	7.56	—	—	—	—	—	—	93
<b>K403</b>	2.36	15.51	8.66	.91	16.46	9.06	—	—	—	—	—	—	—	—	—	—	—	—	100
<b>K513</b>	—	—	—	.59	14.57	6.77	.59	15.59	6.85	.59	16.22	6.97	—	—	—	—	—	—	106
<b>K514</b>	—	—	—	.59	16.26	8.46	—	—	—	—	—	—	—	—	—	—	—	—	109
<b>K613</b>	—	—	—	.71	16.10	7.52	.71	17.12	7.60	.71	17.75	7.72	.71	19.49	8.27	—	—	—	170
<b>K614</b>	—	—	—	.71	17.79	9.21	—	—	—	—	—	—	—	—	—	—	—	—	177
<b>K713</b>	—	—	—	—	—	—	.79	18.42	8.70	.79	19.05	8.82	.79	20.75	9.33	—	—	—	221
<b>K714</b>	—	—	—	.79	19.13	10.35	.79	20.86	11.14	—	—	—	—	—	—	—	—	—	234
<b>K813</b>	—	—	—	—	—	—	.94	20.23	9.72	.94	20.82	9.80	.94	22.52	10.31	—	—	—	309
<b>K814</b>	—	—	—	—	—	—	.94	22.64	12.13	—	—	—	—	—	—	—	—	—	331
<b>K913</b>	—	—	—	—	—	—	—	—	—	.98	23.97	11.57	.98	25.68	12.09	.98	27.17	12.99	508
<b>K914</b>	—	—	—	—	—	—	.98	25.79	13.90	.98	26.77	14.37	—	—	—	—	—	—	530
<b>K1013</b>	—	—	—	—	—	—	—	—	—	—	—	—	1.10	15.43	30.79	1.10	32.29	16.34	913
<b>K1014</b>	—	—	—	—	—	—	—	—	—	1.10	31.89	17.72	—	—	—	—	—	—	993

<sup>1)</sup> Also available as **MR160/050** for a NEMA 56C frame motor.

<sup>2)</sup> Also available as **MR250/180** for a NEMA 182/184TC frame motor.

<sup>3)</sup> Also available as **MR300/180** for a NEMA 182/184TC, **MR300/210** for a NEMA 213/215TC, and **MR300/280** for a NEMA 284/286TC frame motor.

<sup>4)</sup> Also available as **MR350/360** for a NEMA 364/365TC frame motor.

All weights are approximate.

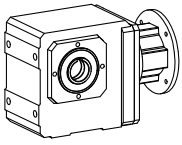

# "K" Series – MGS Reducer Tapped Holes – "G" Housing Hollow Output – Dimensional Data

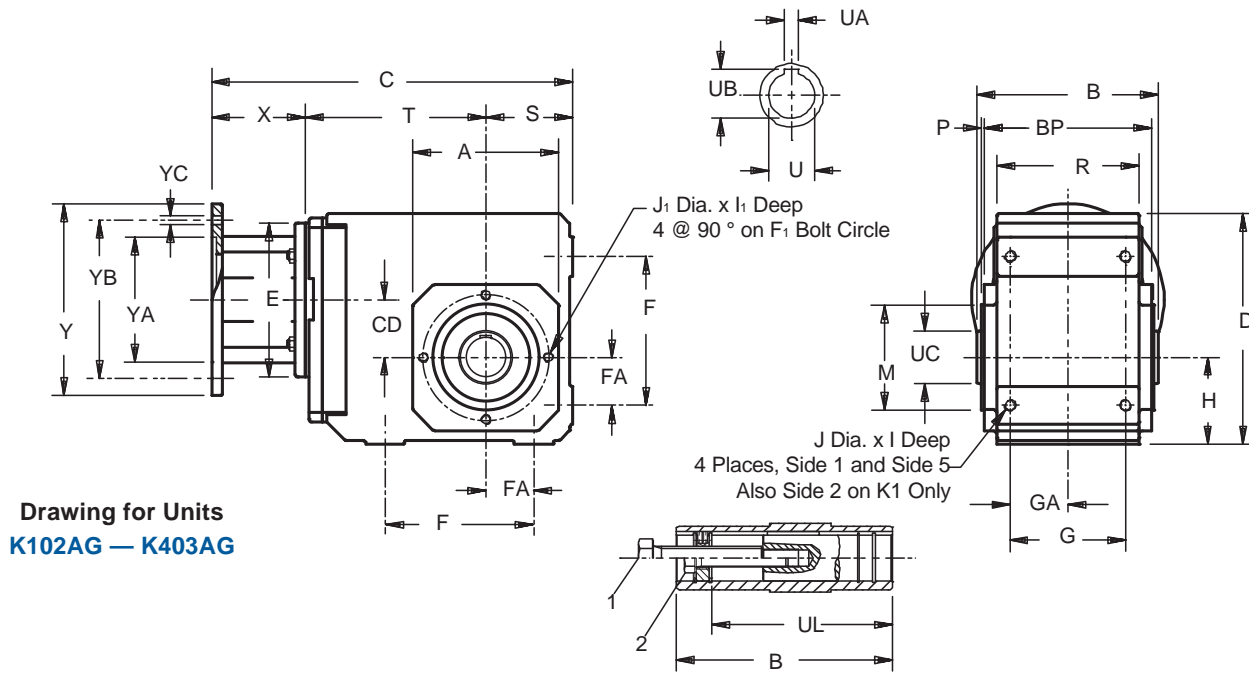

Drawing for Units  
K102AG – K403AG

Table No. 1 "K" Series – Tapped Hole Unit Dimensions (Inches) – "G" Housing Style

Base Module	A	B	D	F	F <sub>1</sub>	G	H	I	I <sub>1</sub>	J	J <sub>1</sub>	M	P	R	S	Z <sub>1</sub>	BP	FA	GA
<b>K102</b>	4.13	4.72	6.30	3.54	3.54	2.76	2.36	.51	.51	M8	M8	2.953 +.001/-0.003	.12	3.54	2.36	—	4.17	1.18	1.38
<b>K202/203</b>	4.57	5.83	7.48	4.53	3.94	3.54	2.56	.63	.51	M10	M8	3.228 +.001/-0.004	.12	4.53	2.56	—	5.28	1.38	1.77
<b>K302/303</b>	5.20	6.30	8.39	5.12	4.53	4.13	2.95	.63	.51	M10	M8	3.740 +.001/-0.004	.12	5.12	2.95	—	5.75	1.57	2.07
<b>K402/403</b>	5.98	7.40	9.45	6.10	5.12	4.72	3.54	.75	.63	M12	M10	4.331 +.001/-0.004	.14	5.83	3.54	—	6.81	1.97	2.36
<b>K513/514</b>	5.71	7.87	10.24	5.51	5.12	4.92	6.30	1.02	.63	M16	M10	4.331 +.001/-0.004	.14	6.30	3.94	5.98	7.28	1.57	2.46
<b>K613/614</b>	7.09	8.46	12.20	6.30	6.50	5.12	7.48	1.02	.63	M16	M10	5.512 +.001/-0.004	.14	6.61	4.72	6.77	7.87	1.97	2.56
<b>K713/714</b>	7.68	9.53	13.46	7.09	7.28	5.71	8.35	1.22	.75	M20	M12	6.102 +.001/-0.004	.14	7.48	4.92	7.52	8.90	2.17	2.85
<b>K813/814</b>	8.90	11.81	16.14	9.45	8.46	7.28	10.43	1.50	.75	M24	M12	7.283 +.001/-0.001	.16	9.25	5.71	8.11	11.10	2.95	3.64
<b>K913/914</b>	11.02	13.78	19.49	11.02	10.43	8.86	12.40	1.89	1.02	M30	M16	9.055 +.001/-0.001	.20	11.22	7.09	9.84	12.99	3.74	4.43
<b>K1013/1014</b>	13.38	16.14	23.27	11.81	11.81	12.99	14.76	1.77	1.30	M20	M20	9.843 +.001/-0.001	.28	15.59	8.86	12.01	15.60	4.53	6.50

Table No. 2

Base Module	UC	UL	1
<b>K102</b>	1.57	3.86	1/2-13
<b>K202/203</b>	1.77	4.78	1/2-13
<b>K302/303</b>	1.97	4.92	5/8-11
<b>K402/403</b>	2.17	6.18	3/4-10
<b>K513/514</b>	2.56	6.46	3/4-10
<b>K613/614</b>	2.76	7.05	3/4-10
<b>K713/714</b>	3.35	8.43	1-8
<b>K813/814</b>	3.94	10.35	1-8
<b>K913/914</b>	4.33	11.89	1-8
<b>K1013/1014</b>	5.12	14.25	1 1/4-7

1. Removal Bolt —not supplied.
2. Mounting Bolt —must be smaller than removal bolt.

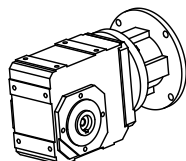

K1 Housing with tapped holes on Side 1, Side 2, and Side 5.

Table No. 3 Motor Adapter Dimensions (Inches)

Motor Adapter	NEMA C-Flange	E	X	Y	YA	YB	YC	Wt. lbs.
<b>MR140/050</b>	56C	5.51	3.31	6.50	4.500	5.87	.41	9
<b>MR160/050</b>	56C	6.30	3.86	6.50	4.500	5.87	.41	16
<b>MR160/140</b>	143/145TC	6.30	3.86	6.50	4.500	5.87	.41	16
<b>MR200/180</b>	182/184TC	7.87	4.80	9.00	8.500	7.25	.55	23
<b>MR250/180</b>	182/184TC	9.84	5.31	9.00	8.500	7.25	.55	36
<b>MR250/210</b>	213/215TC	9.84	5.31	9.00	8.500	7.25	.55	36
<b>MR300/180</b>	182/184TC	11.81	6.50	9.00	8.500	7.25	.57	75
<b>MR300/210</b>	213/215TC	11.81	6.50	9.00	8.500	7.25	.57	75
<b>MR300/250</b>	254/256TC	11.81	6.50	9.00	8.500	7.25	.57	75
<b>MR300/280</b>	284/286TC	11.81	6.50	11.13	10.500	9.00	.57	75
<b>MR350/320</b>	324/326TC	13.78	7.09	13.37	12.500	11.00	.70	133
<b>MR350/360</b>	364/365TC	13.78	7.09	13.37	12.500	11.00	.70	133

Part No. Example

Tapped Holes Housing with Motor Adapter  
**K303AG0650 MR160/140**



# "K" Series – MGS Reducer Tapped Holes – "G" Housing Hollow Output – Dimensional Data

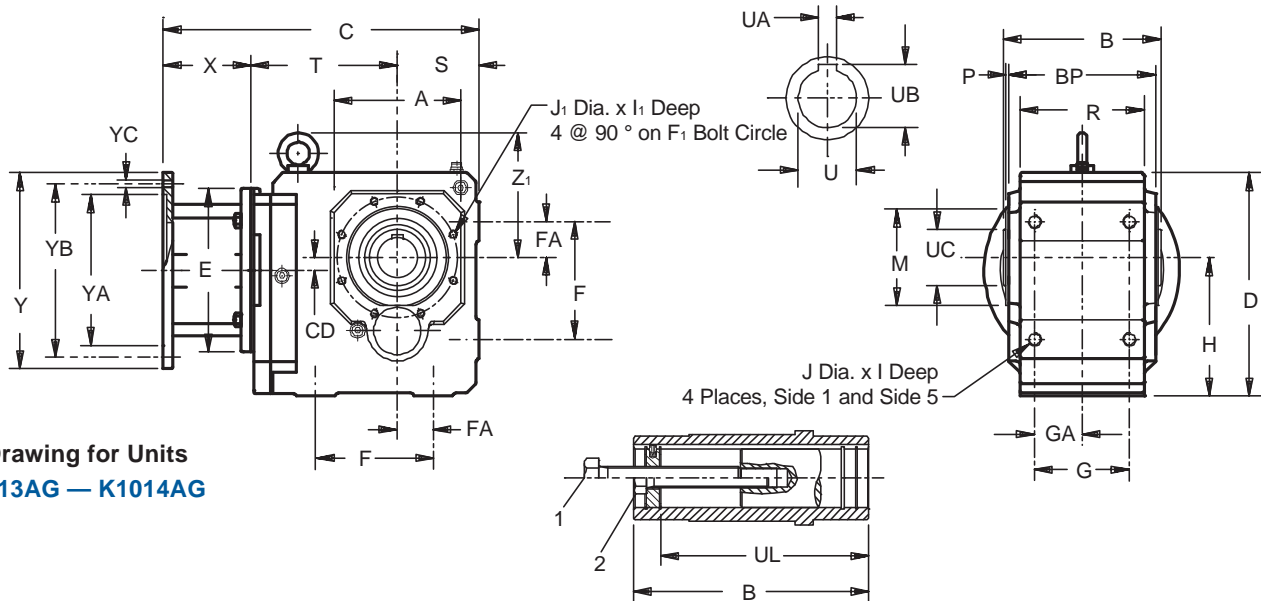
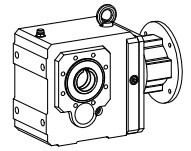

Drawing for Units  
K513AG – K1014AG

Table No. 4 Metric output available on request.

Base Module	Standard Bore - inches			Optional Bore - mm		
	U	UA	UB	U	UA	UB
K102	1.000	.250	1.11	25 <sub>H7</sub>	8 <sub>JS9</sub>	28.3
K202/203	1.1875	.250	1.31	30 <sub>H7</sub>	8 <sub>JS9</sub>	33.3
K302/303	1.375	.312	1.52	35 <sub>H7</sub>	10 <sub>JS9</sub>	38.3
K402/403	1.500	.375	1.67	40 <sub>H7</sub>	12 <sub>JS9</sub>	43.3
K513/514	2.000	.500	2.13	50 <sub>H7</sub>	14 <sub>JS9</sub>	53.8
K613/614	2.000	.500	2.23	50 <sub>H7</sub>	14 <sub>JS9</sub>	53.8
K713/714	2.375	.625	2.66	60 <sub>H7</sub>	18 <sub>JS9</sub>	64.4
K813/814	2.750	.625	3.03	70 <sub>H7</sub>	20 <sub>JS9</sub>	74.9
K913/914	3.250	.750	3.59	90 <sub>H7</sub>	25 <sub>JS9</sub>	95.4
K1013/1014	4.000	1.000	4.31	100 <sub>H7</sub>	28 <sub>JS9</sub>	116

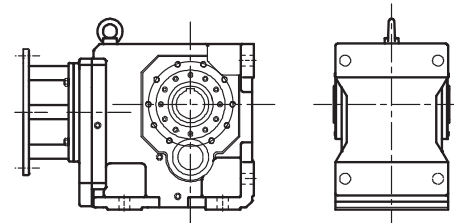

Typical K10 housing.

Table No. 5 "K" Series – Tapped Hole Unit Dimensions (Inches) – "G" Housing Style

Base Module	MR140/050			MR160/140 <sup>1)</sup>			MR200/180			MR250/210 <sup>2)</sup>			MR300/250 <sup>3)</sup>			MR350/320 <sup>4)</sup>			Wt. lbs.	
	CD	C	T	CD	C	T	CD	C	T	CD	C	T	CD	C	T	CD	C	T		
K102	1.42	10.55	4.88	1.42	11.26	5.04	—	—	—	—	—	—	—	—	—	—	—	—	—	31
K202	1.81	11.50	5.63	1.81	12.21	5.79	1.81	13.23	5.87	—	—	—	—	—	—	—	—	—	—	40
K203	1.81	12.96	7.09	—	—	—	—	—	—	—	—	—	—	—	—	—	—	—	—	53
K302	2.07	12.68	6.42	2.07	13.38	6.57	2.07	14.40	6.65	—	—	—	—	—	—	—	—	—	—	67
K303	2.07	14.13	7.87	.63	15.08	8.27	—	—	—	—	—	—	—	—	—	—	—	—	—	73
K402	—	—	—	2.36	14.76	7.36	2.36	15.74	7.44	2.36	16.41	7.56	—	—	—	—	—	—	—	93
K403	2.36	15.51	8.66	.91	16.46	9.06	—	—	—	—	—	—	—	—	—	—	—	—	—	100
K513	—	—	—	.59	14.57	6.77	.59	15.59	6.85	.59	16.22	6.97	—	—	—	—	—	—	—	106
K514	—	—	—	.59	16.26	8.46	—	—	—	—	—	—	—	—	—	—	—	—	—	109
K613	—	—	—	.71	16.10	7.52	.71	17.12	7.60	.71	17.75	7.72	.71	19.49	8.27	—	—	—	—	170
K614	—	—	—	.71	17.79	9.21	—	—	—	—	—	—	—	—	—	—	—	—	—	177
K713	—	—	—	—	—	—	.79	18.42	8.70	.79	19.05	8.82	.79	20.75	9.33	—	—	—	—	221
K714	—	—	—	.79	19.13	10.35	.79	20.86	11.14	—	—	—	—	—	—	—	—	—	—	234
K813	—	—	—	—	—	—	.94	20.23	9.72	.94	20.82	9.80	.94	22.52	10.31	—	—	—	—	309
K814	—	—	—	—	—	—	.94	22.64	12.13	—	—	—	—	—	—	—	—	—	—	331
K913	—	—	—	—	—	—	—	—	—	.98	23.97	11.57	.98	25.68	12.09	.98	27.17	12.99	—	508
K914	—	—	—	—	—	—	.98	25.79	13.90	.98	26.77	14.37	—	—	—	—	—	—	—	530
K1013	—	—	—	—	—	—	—	—	—	—	—	—	1.10	15.43	30.79	1.10	32.29	16.34	—	913
K1014	—	—	—	—	—	—	—	—	—	1.10	31.89	17.72	—	—	—	—	—	—	—	993

<sup>1)</sup> Also available as MR160/050 for a NEMA 56C frame motor.

<sup>2)</sup> Also available as MR250/180 for a NEMA 182/184TC frame motor.

<sup>3)</sup> Also available as MR300/180 for a NEMA 182/184TC, MR300/210 for a NEMA 213/215TC, and MR300/280 for a NEMA 284/286TC frame motor.

<sup>4)</sup> Also available as MR350/360 for a NEMA 364/365TC frame motor.

All weights are approximate.

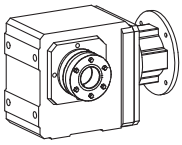

# "K" Series – MGS Reducer Tapped Holes – "G" Housing Double Bushing – Dimensional Data

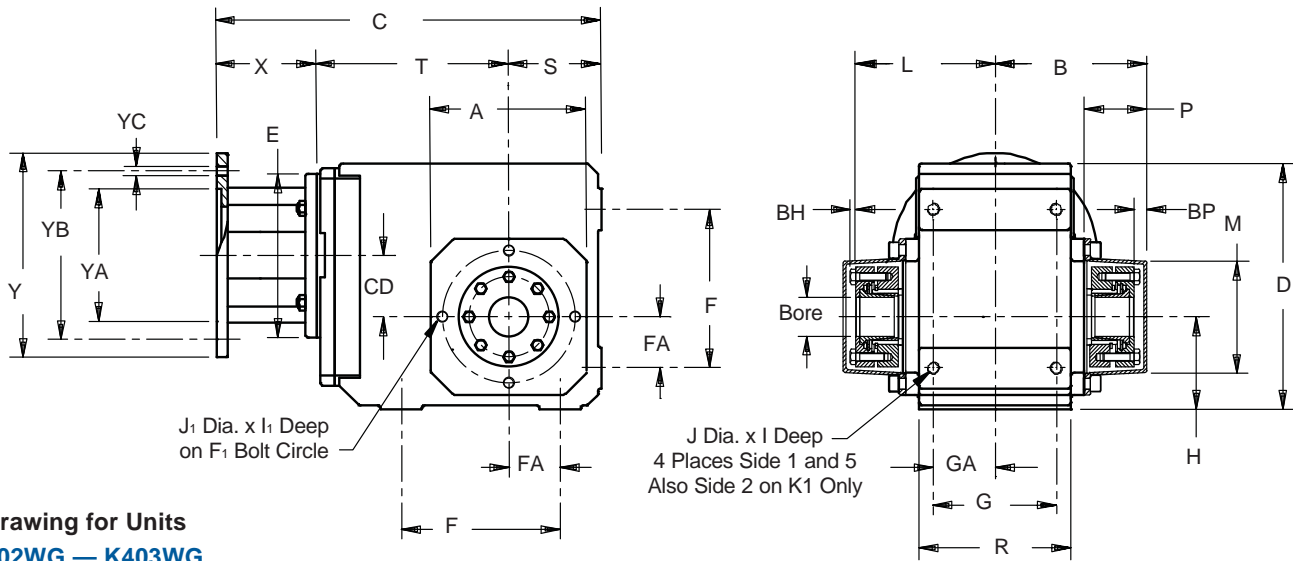

Drawing for Units  
K102WG – K403WG

Table No. 1 "K" Series – Double Wobble Free – Unit Dimensions (Inches)

Base Module	Max. Bore	A	B	D	F	F <sub>1</sub>	G	H	I	I <sub>1</sub>	J	J <sub>1</sub>	L	M	P	R	S	Z <sub>1</sub>	BP	BH	FA	GA
<b>K102</b>	1.000	4.13	3.90	6.30	3.54	3.54	2.76	2.36	.51	.51	M8	M8	3.66	3.07	1.97	3.54	2.36	—	.24	.16	1.18	1.38
<b>K202/203</b>	1.187	4.57	4.68	7.48	4.53	3.94	3.54	2.56	.63	.51	M10	M8	4.26	3.46	2.05	4.53	2.56	—	.39	.16	1.38	1.77
<b>K302/303</b>	1.500	5.20	4.98	8.39	5.12	4.53	4.13	2.95	.63	.51	M10	M8	4.54	3.78	2.09	5.12	2.95	—	.43	.16	1.57	2.07
<b>K402/403</b>	1.500	5.98	5.80	9.45	6.10	5.12	4.72	3.54	.75	.63	M12	M10	5.33	4.33	2.40	5.83	3.54	—	.47	.20	1.97	2.36
<b>K513/514</b>	2.000	5.71	6.05	10.24	5.51	5.12	4.92	6.30	1.02	.63	M16	M10	5.61	4.54	2.40	6.30	3.94	5.98	.43	.20	1.57	2.46
<b>K613/614</b>	2.187	7.09	6.61	12.20	6.30	6.50	5.12	7.48	1.02	.63	M16	M10	6.10	5.00	2.68	6.61	4.72	6.77	.51	.24	1.97	2.56
<b>K713/714</b>	2.375	7.68	7.68	13.46	7.09	7.28	5.71	8.35	1.22	.75	M20	M12	7.29	5.75	2.91	7.48	4.92	7.52	.39	.24	2.17	2.85
<b>K813/814</b>	2.750	8.90	9.34	16.14	9.45	8.46	7.28	10.43	1.50	.75	M24	M12	8.70	6.95	3.43	9.25	5.71	8.11	.64	.31	2.95	3.64

Table No. 2 Motor Adapter Dimensions (Inches)

Motor Adapter	NEMA C-Flange	E	X	Y	YA	YB	YC	Wt. lbs.
<b>MR140/050</b>	56C	5.51	3.31	6.50	4.500	5.87	.41	9
<b>MR160/050</b>	56C	6.30	3.86	6.50	4.500	5.87	.41	16
<b>MR160/140</b>	143/145TC	6.30	3.86	6.50	4.500	5.87	.41	16
<b>MR200/180</b>	182/184TC	7.87	4.80	9.00	8.500	7.25	.55	23
<b>MR250/180</b>	182/184TC	9.84	5.31	9.00	8.500	7.25	.55	36
<b>MR250/210</b>	213/215TC	9.84	5.31	9.00	8.500	7.25	.55	36
<b>MR300/180</b>	182/184TC	11.81	6.50	9.00	8.500	7.25	.57	75
<b>MR300/210</b>	213/215TC	11.81	6.50	9.00	8.500	7.25	.57	75
<b>MR300/250</b>	254/256TC	11.81	6.50	9.00	8.500	7.25	.57	75
<b>MR300/280</b>	284/286TC	11.81	6.50	11.13	10.500	9.00	.57	75

**Part No. Example**  
143TC Frame Motor Adapter  
and 17/16 Bushing Bore  
**K303WG0650 MR160/140**  
**WFB3-107**

Table No. 3 "WFB" – Double Side Bushings – Metric

Unit	Stock Bore Sizes – mm			
	25	30	35	40
<b>K1</b>	<b>WFB1-25</b>	—	—	—
<b>K2</b>	—	<b>WFB2-30</b>	—	—
<b>K3</b>	—	<b>WFB3-30</b>	<b>WFB3-35</b>	—
<b>K4</b>	—	—	—	<b>WFB4-40</b>
<b>K5</b>	—	—	—	<b>WFB5-40</b>
<b>K6</b>	—	—	—	<b>WFB6-40</b>

Table No. 4 "WFB" Double Side Bushings – Inches

Unit	Stock Bore Sizes					
	1	1 <sup>3</sup> / <sub>16</sub>	1 <sup>1</sup> / <sub>4</sub>	1 <sup>3</sup> / <sub>8</sub>	1 <sup>7</sup> / <sub>16</sub>	1 <sup>1</sup> / <sub>2</sub>
<b>K1</b>	<b>WFB1-100</b>	—	—	—	—	—
<b>K2</b>	<b>WFB2-100</b>	<b>WFB2-103</b>	—	—	—	—
<b>K3</b>	<b>WFB3-100</b>	<b>WFB3-103</b>	<b>WFB3-104</b>	<b>WFB3-106</b>	<b>WFB3-107</b>	<b>WFB3-108</b>
<b>K4</b>	<b>WFB4-100</b>	<b>WFB4-103</b>	<b>WFB4-104</b>	<b>WFB4-106</b>	<b>WFB4-107</b>	<b>WFB4-108</b>





# "K" Series – MGS Reducer Tapped Holes – "G" Housing Double Bushing – Dimensional Data

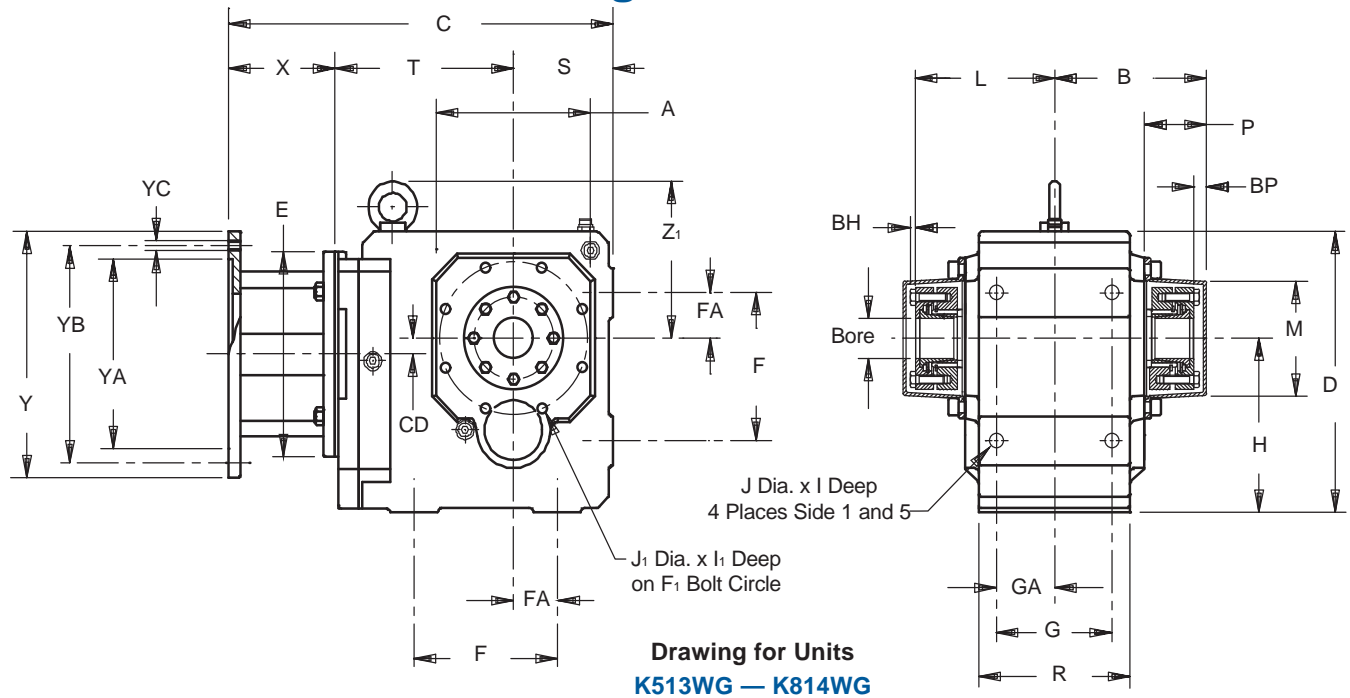
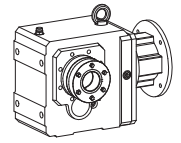

**Table No. 5 "K" Series – Double Wobble Free – Unit Dimensions (Inches)**

Base Module	MR140/050			MR160/140 <sup>1)</sup>			MR200/180			MR250/210 <sup>2)</sup>			MR300/250 <sup>3)</sup>			Wt. lbs.
	CD	C	T	CD	C	T	CD	C	T	CD	C	T	CD	C	T	
K102	1.42	10.55	4.88	1.42	11.26	5.04	—	—	—	—	—	—	—	—	—	31
K202	1.81	11.50	5.63	1.81	12.21	5.79	1.81	13.23	5.87	—	—	—	—	—	—	40
K203	1.81	12.96	7.09	—	—	—	—	—	—	—	—	—	—	—	—	53
K302	2.07	12.68	6.42	2.07	13.38	6.57	2.07	14.40	6.65	—	—	—	—	—	—	67
K303	2.07	14.13	7.87	.63	15.08	8.27	—	—	—	—	—	—	—	—	—	73
K402	—	—	—	2.36	14.76	7.36	2.36	15.74	7.44	2.36	16.41	7.56	—	—	—	93
K403	2.36	15.51	8.66	.91	16.46	9.06	—	—	—	—	—	—	—	—	—	100
K513	—	—	—	.59	14.57	6.77	.59	15.59	6.85	.59	16.22	6.97	—	—	—	106
K514	—	—	—	.59	16.26	8.46	—	—	—	—	—	—	—	—	—	109
K613	—	—	—	.71	16.10	7.52	.71	17.12	7.60	.71	17.75	7.72	.71	19.49	8.27	170
K614	—	—	—	.71	17.79	9.21	—	—	—	—	—	—	—	—	—	177
K713	—	—	—	—	—	—	.79	18.42	8.70	.79	19.05	8.82	.79	20.75	9.33	221
K714	—	—	—	.79	19.13	10.35	.79	20.86	11.14	—	—	—	—	—	—	234
K813	—	—	—	—	—	—	.94	20.23	9.72	.94	20.82	9.80	.94	22.52	10.31	309
K814	—	—	—	—	—	—	.94	22.64	12.13	—	—	—	—	—	—	331

<sup>1)</sup> Also available as **MR160/050** for a NEMA 56C frame motor.

<sup>2)</sup> Also available as **MR250/180** for a NEMA 182/184TC frame motor.

<sup>3)</sup> Also available as **MR300/180** for a NEMA 182/184TC, **MR300/210** for a NEMA 213/215TC, and **MR300/280** for a NEMA 284/286TC frame motor. All weights are approximate.

**NOTE:** A double side bushing kit includes 2 each of a pressure ring and clamp ring, flanged and tapered cone, and all hardware to mount the kit into the reducer. The WFB1 does not use a tapered cone. All double bushing kits include covers. The bushing will accept a shaft with a tolerance of +.000/-0.005.

**Table No. 6 "WFB" Double Side Bushings – Inches**

Unit	Stock Bores Sizes – Inches											
	1 <sup>7</sup> / <sub>16</sub>	1 <sup>1</sup> / <sub>2</sub>	1 <sup>5</sup> / <sub>8</sub>	1 <sup>11</sup> / <sub>16</sub>	1 <sup>3</sup> / <sub>4</sub>	1 <sup>7</sup> / <sub>8</sub>	1 <sup>15</sup> / <sub>16</sub>	2	2 <sup>3</sup> / <sub>16</sub>	2 <sup>3</sup> / <sub>8</sub>	2 <sup>7</sup> / <sub>16</sub>	2 <sup>3</sup> / <sub>4</sub>
K5	WFB5-107	WFB5-108	WFB5-110	WFB5-111	WFB5-112	WFB5-114	WFB5-115	WFB5-200	—	—	—	—
K6	WFB6-107	WFB6-108	WFB6-110	WFB6-111	WFB6-112	—	WFB6-115	WFB6-200	WFB6-203	—	—	—
K7	—	—	—	—	—	—	WFB7-115	WFB7-200	WFB7-203	WFB7-206	—	—
K8	—	—	—	—	—	—	—	—	WFB8-203	WFB8-206	WFB8-207	WFB8-212

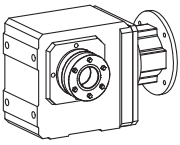

# "K" Series – MGS Reducer Tapped Holes – "G" Housing Single Bushing – Dimensional Data

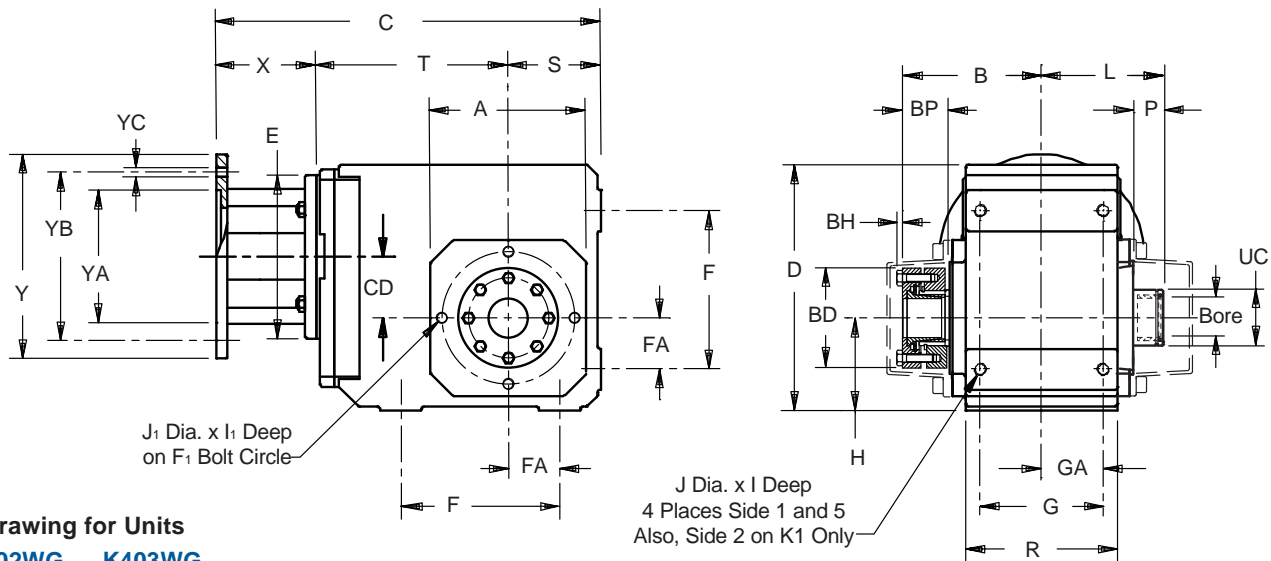

Drawing for Units  
K102WG – K403WG

Table No. 1 "K" Series – Single Side Wobble Free Bushing – Unit Dimensions (Inches)

Base Module	A	B	D	F	F <sub>1</sub>	G	H	I	I <sub>1</sub>	J	J <sub>1</sub>	L	P	R	S	Z <sub>1</sub>	BD	BP	BH	FA	GA	UC
<b>K102</b>	4.13	3.66	6.30	3.54	3.54	2.76	2.36	.51	.51	M8	M8	3.15	1.97	3.54	2.36	—	2.76	1.62	.16	1.18	1.38	1.54
<b>K202/203</b>	4.57	4.29	7.48	4.53	3.94	3.54	2.567	.63	.51	M10	M8	3.78	2.05	4.53	2.56	—	3.07	1.54	.16	1.38	1.7	1.73
<b>K302/303</b>	5.20	4.54	8.39	5.12	4.53	4.13	2.95	.63	.51	M10	M8	4.02	2.09	5.12	2.95	—	3.31	1.55	.16	1.57	2.07	1.93
<b>K402/403</b>	5.98	5.33	9.45	6.10	5.12	4.72	3.54	.75	.63	M12	M10	4.69	2.40	5.83	3.54	—	3.82	1.83	.20	1.97	2.36	2.13
<b>K513/514</b>	5.71	5.61	10.24	5.51	5.12	4.92	6.30	1.02	.63	M16	M10	4.96	2.40	6.30	3.94	5.98	4.13	1.87	.20	1.57	2.46	2.56
<b>K613/614</b>	7.09	6.10	12.20	6.30	6.50	5.12	7.48	1.02	.63	M16	M10	5.12	2.68	6.61	4.72	6.77	4.65	2.11	.24	1.97	2.56	2.91
<b>K713/714</b>	7.68	7.29	13.46	7.09	7.28	5.71	8.35	1.22	.75	M20	M12	6.20	2.91	7.48	4.92	7.52	5.43	2.70	.24	2.17	2.85	3.35
<b>K813/814</b>	8.90	8.70	16.14	9.45	8.46	7.28	10.43	1.50	.75	M24	M12	7.58	3.43	9.25	5.71	8.11	6.22	2.99	.31	2.95	3.64	3.94

Table No. 2 Motor Adapter Dimensions (Inches)

Motor Adapter	NEMA C-Flange	E	X	Y	YA	YB	YC	Wt. lbs.
<b>MR140/050</b>	56C	5.51	3.31	6.50	4.500	5.87	.41	9
<b>MR160/050</b>	56C	6.30	3.86	6.50	4.500	5.87	.41	16
<b>MR160/140</b>	143/145TC	6.30	3.86	6.50	4.500	5.87	.41	16
<b>MR200/180</b>	182/184TC	7.87	4.80	9.00	8.500	7.25	.55	23
<b>MR250/180</b>	182/184TC	9.84	5.31	9.00	8.500	7.25	.55	36
<b>MR250/210</b>	213/215TC	9.84	5.31	9.00	8.500	7.25	.55	36
<b>MR300/180</b>	182/184TC	11.81	6.50	9.00	8.500	7.25	.57	75
<b>MR300/210</b>	213/215TC	11.81	6.50	9.00	8.500	7.25	.57	75
<b>MR300/250</b>	254/256TC	11.81	6.50	9.00	8.500	7.25	.57	75
<b>MR300/280</b>	284/286TC	11.81	6.50	11.13	10.500	9.00	.57	75

**Part No. Example**  
143TC Frame Motor Adapter  
and 17/16 Bushing Bore  
**K303WG0650 MR160/140**  
**WF3-107**

Table No. 3 "WF" Single Side Bushing – Metric

Unit	Stock Bore Sizes – mm		
	25	30	35
<b>K1</b>	<b>WF1-25</b>	—	—
<b>K2</b>	—	<b>WF2-30</b>	—
<b>K3</b>	—	<b>WF3-30</b>	<b>WF3-35</b>

Table No. 4 "WF" Single Side Bushings

Unit	Stock Bore Sizes					
	1	1 <sup>3</sup> / <sub>16</sub>	1 <sup>1</sup> / <sub>4</sub>	1 <sup>3</sup> / <sub>8</sub>	1 <sup>7</sup> / <sub>16</sub>	1 <sup>1</sup> / <sub>2</sub>
<b>K1</b>	<b>WF1-100</b>	—	—	—	—	—
<b>K2</b>	<b>WF2-100</b>	<b>WF2-103</b>	—	—	—	—
<b>K3</b>	<b>WF3-100</b>	<b>WF3-103</b>	<b>WF3-104</b>	<b>WF3-106</b>	<b>WF3-107</b>	<b>WF3-108</b>
<b>K4</b>	<b>WF4-100</b>	<b>WF4-103</b>	<b>WF4-104</b>	<b>WF4-106</b>	<b>WF4-107</b>	<b>WF4-108</b>



# "K" Series – MGS Reducer Tapped Holes – "G" Housing Single Bushing – Dimensional Data

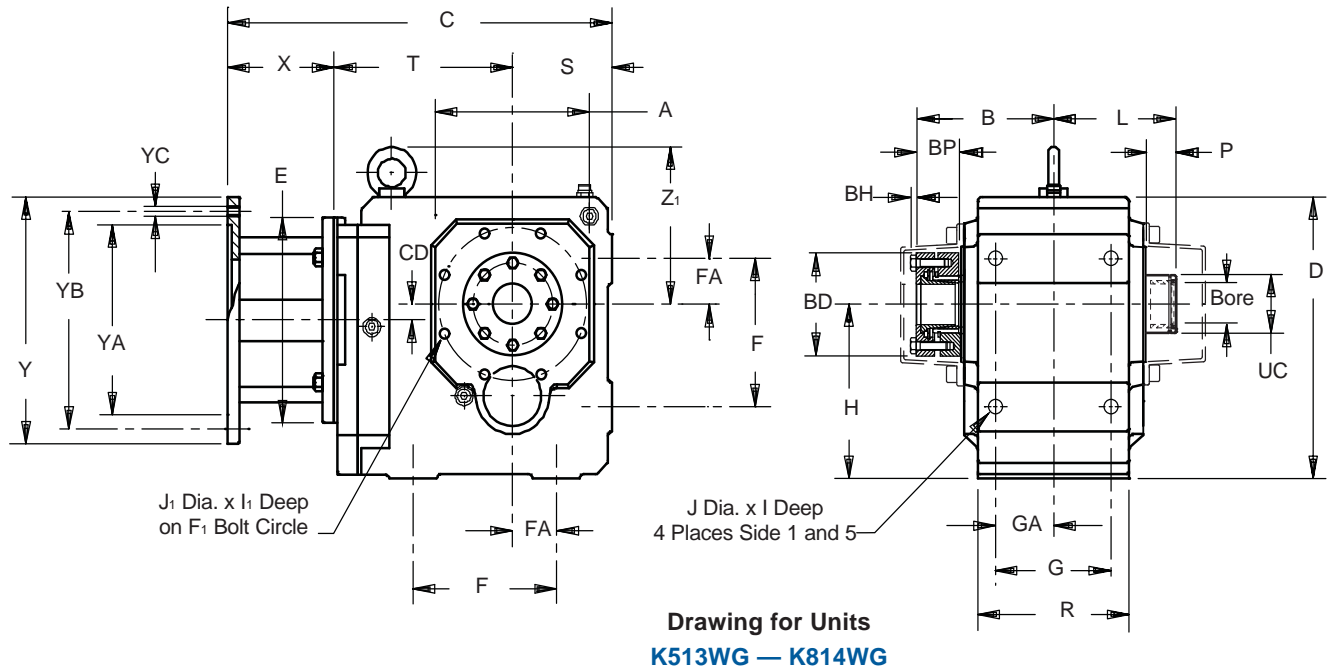
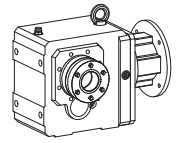

**Table No. 5 "K" Series – Single Side Wobble Free Bushing – Unit Dimensions (Inches)**

Base	MR140/050			MR160/140 <sup>1)</sup>			MR200/180			MR250/210 <sup>2)</sup>			MR300/250 <sup>3)</sup>			Wt.
Module	CD	C	T	CD	C	T	CD	C	T	CD	C	T	CD	C	T	lbs.
K102	1.42	10.55	4.88	1.42	11.26	5.04	—	—	—	—	—	—	—	—	—	31
K202	1.81	11.50	5.63	1.81	12.21	5.79	1.81	13.23	5.87	—	—	—	—	—	—	40
K203	1.81	12.96	7.09	—	—	—	—	—	—	—	—	—	—	—	—	53
K302	2.07	12.68	6.42	2.07	13.38	6.57	2.07	14.40	6.65	—	—	—	—	—	—	67
K303	2.07	14.13	7.87	.63	15.08	8.27	—	—	—	—	—	—	—	—	—	73
K402	—	—	—	2.36	14.76	7.36	2.36	15.74	7.44	2.36	16.41	7.56	—	—	—	93
K403	2.36	15.51	8.66	.91	16.46	9.06	—	—	—	—	—	—	—	—	—	100
K513	—	—	—	.59	14.57	6.77	.59	15.59	6.85	.59	16.22	6.97	—	—	—	106
K514	—	—	—	.59	16.26	8.46	—	—	—	—	—	—	—	—	—	109
K613	—	—	—	.71	16.10	7.52	.71	17.12	7.60	.71	17.75	7.72	.71	19.49	8.27	170
K614	—	—	—	.71	17.79	9.21	—	—	—	—	—	—	—	—	—	177
K713	—	—	—	—	—	—	.79	18.42	8.70	.79	19.05	8.82	.79	20.75	9.33	221
K714	—	—	—	.79	19.13	10.35	.79	20.86	11.14	—	—	—	—	—	—	234
K813	—	—	—	—	—	—	.94	20.23	9.72	.94	20.82	9.80	.94	22.52	10.31	309
K814	—	—	—	—	—	—	.94	22.64	12.13	—	—	—	—	—	—	331

<sup>1)</sup> Also available as **MR160/050** for a NEMA 56C frame motor.

<sup>2)</sup> Also available as **MR250/180** for a NEMA 182/184TC frame motor.

<sup>3)</sup> Also available as **MR300/180** for a NEMA 182/184TC, **MR300/210** for a NEMA 213/215TC, and **MR300/280** for a NEMA 284/286TC frame motor.

All weights are approximate.

**NOTE:** Single side bushing kits include 1 each of the pressure and locking ring, tapered cone, support ring, and all hardware to mount the kit into the MGS reducer. The WF1 bushing does not use a tapered cone. Covers are optional. The bushing will accept a shaft with a tolerance of +.000/- .005.

**Table No. 6 "WF" Single Side Bushings**

Unit	Stock Bores Sizes											
	17/16	1 1/2	1 5/8	1 11/16	1 3/4	1 7/8	1 15/16	2	2 3/16	2 3/8	2 7/16	2 3/4
K5	WF5-107	WF5-108	WF5-110	WF5-111	WF5-112	WF5-114	WF5-115	WF5-200	—	—	—	—
K6	WF6-107	WF6-108	WF6-110	WF6-111	WF6-112	—	WF6-115	WF6-200	WF6-203	—	—	—
K7	—	—	—	—	—	—	WF7-115	WF7-200	WF7-203	WF7-206	—	—
K8	—	—	—	—	—	—	—	—	WF8-203	WF8-206	WF8-207	WF8-212



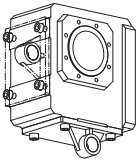

# "K" Series – MGS Reducer Torque Arm Bracket (torque arm supplied by others)



All brackets can be mounted on all units K102 through K1014 on Side 1 and Side 5.  
The bracket can be mounted on the top side (Side 2) of K102 ONLY.

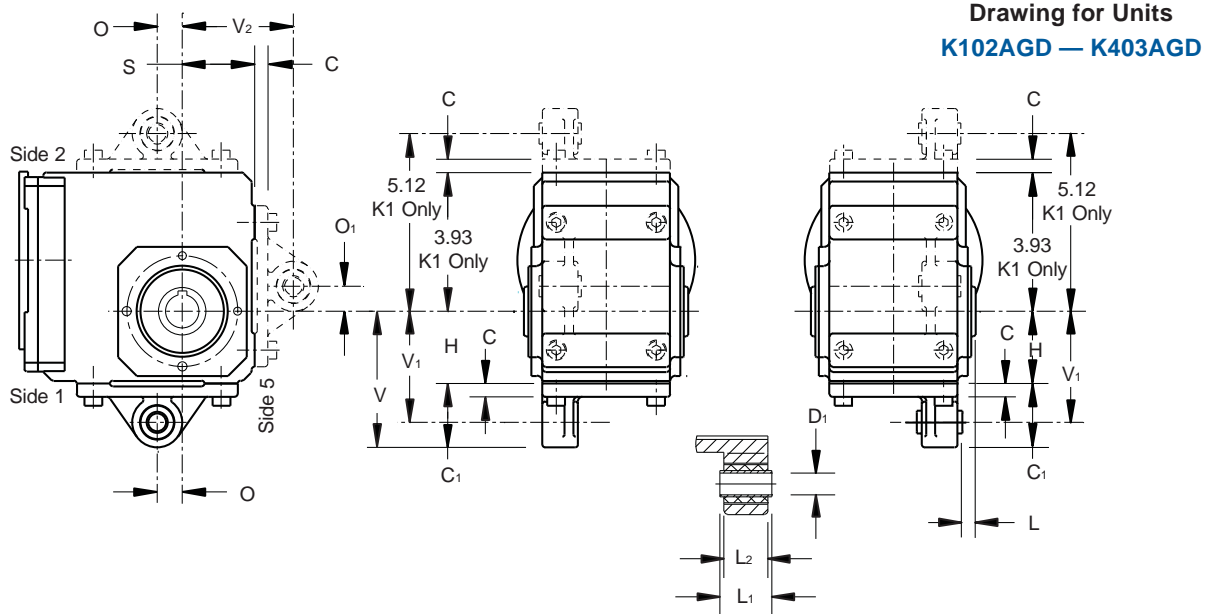

**Table No. 1 "K" Series — Torque Arm Bracket Dimensions (Inches)**

Base Module	C	C <sub>1</sub>	D <sub>1</sub>	H <sub>9</sub>	H	L	L <sub>1</sub>	L <sub>2</sub>	O	O <sub>1</sub>	S	V	V <sub>1</sub>	V <sub>2</sub>
<b>K102</b>	.39	2.03	.47	+0.017/-0.000	2.36	.51	1.10	.94	.59	.59	2.36	4.39	3.54	3.54
<b>K202/K203</b>	.47	2.26	.63	+0.017/-0.000	2.56	.53	1.50	1.26	.89	.89	2.56	4.82	3.93	3.93
<b>K302/K303</b>	.47	2.66	.63	+0.017/-0.000	2.95	.47	1.50	1.26	.98	.98	2.95	5.61	4.72	4.72
<b>K402/K403</b>	.55	3.46	.79	+0.020/-0.000	3.54	.67	1.81	1.57	1.08	1.08	3.54	7.00	5.91	5.91
<b>K513/K514</b>	.59	4.68	.79	+0.020/-0.000	6.30	.67	1.81	1.57	1.18	1.18	3.93	10.98	9.84	7.48
<b>K613/K614</b>	.59	3.50	.79	+0.020/-0.000	7.48	.81	1.81	1.57	1.18	1.18	4.72	10.98	9.84	7.09
<b>K713/K714</b>	.67	4.80	.79	+0.020/-0.000	8.35	.91	2.76	2.52	1.38	1.38	4.92	13.15	11.81	8.39
<b>K813/K814</b>	.67	4.77	.94	+0.020/-0.000	10.43	1.02	4.53	4.02	1.77	1.77	5.71	15.20	13.78	9.06
<b>K913/K914</b>	.79	6.80	.94	+0.020/-0.000	12.40	1.02	4.53	4.02	1.77	1.77	7.09	19.20	17.72	12.40
<b>K1013/K1014</b>	1.65	9.25	1.57	+0.024/-0.000	14.76	.24	4.88	4.65	2.36	2.17	8.86	24.01	21.65	15.75

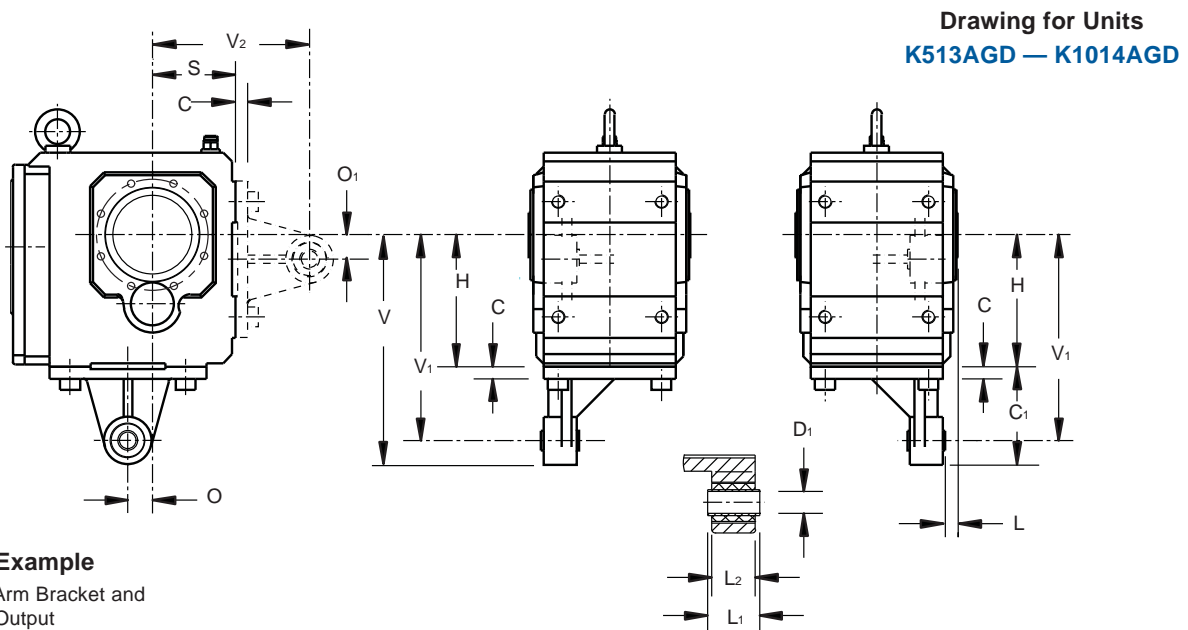

**Part No. Example**

Unit with Torque Arm Bracket and  
Hollow Output  
**K513AGD0650**





# "K" Series – MGS Reducer Torque Arm Mounting Method (torque arm supplied by others)

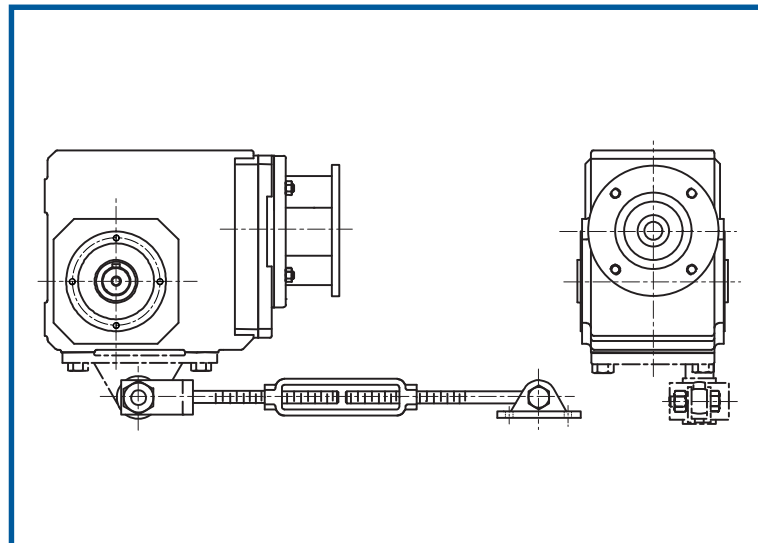
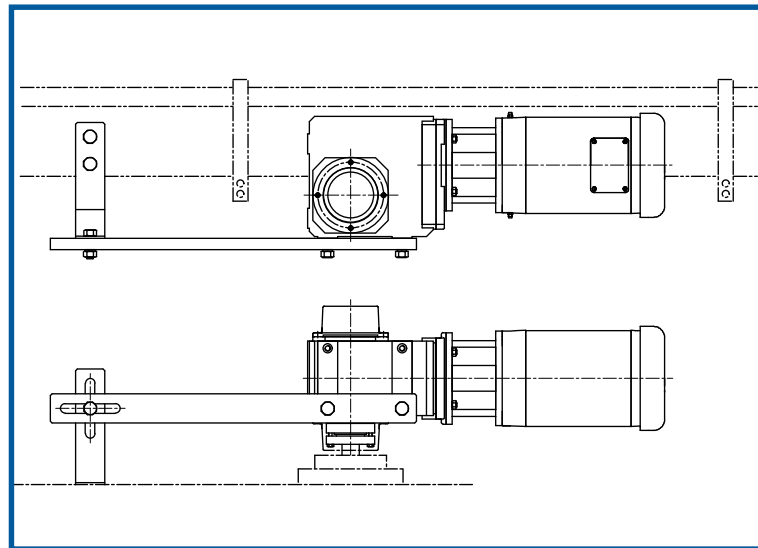
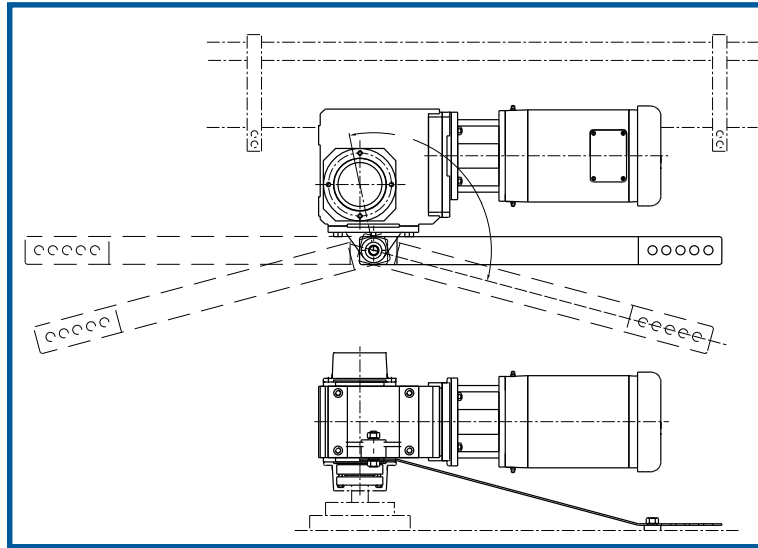



# **“S” Series Right Angle Helical/Worm Speed Reducers**

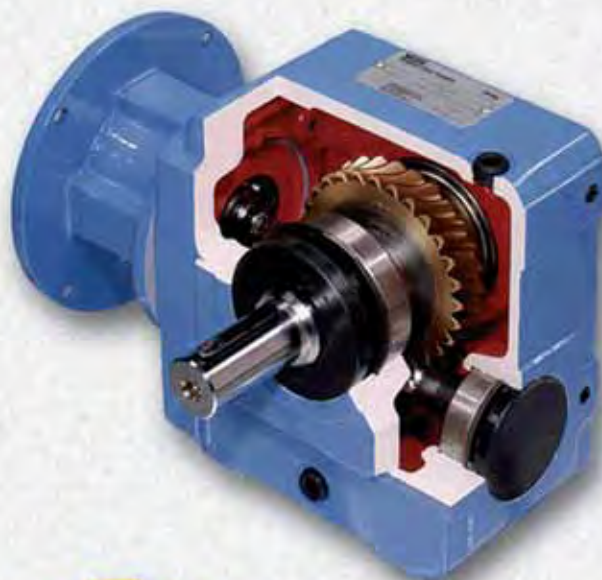

**3 YEAR WARRANTY**

**3-DAY  
DELIVERY**



[www.stober.com](http://www.stober.com)

# "S" Series – Right Angle Helical/Worm MGS Speed Reducers



These durable units combine economy and versatility for a wide range of applications. MGS helical-before-worm gearing offers twice the efficiency of two-stage worm drives.

**Performance Specifications:**

- Horsepower ratings from 1/8 to 8.19
- Output torques to 7,086 in. lbs.
- Output speeds available from 318 to 2.5 RPM
- Speed reducer ratios from 9.2:1 to 683:1
- 3 year warranty– your assurance of satisfactory product performance



**Input Options:**

- Input shaft
- NEMA C-face Adapter (coupling type)

Centrifugally cast bronze worm gear and precision worm provide excellent torque carrying capacity and high efficiency

Stainless steel nameplate and hardware

Strategically located oil fill, drain and breather ports for optimum mounting flexibility. Oil sight glass available.

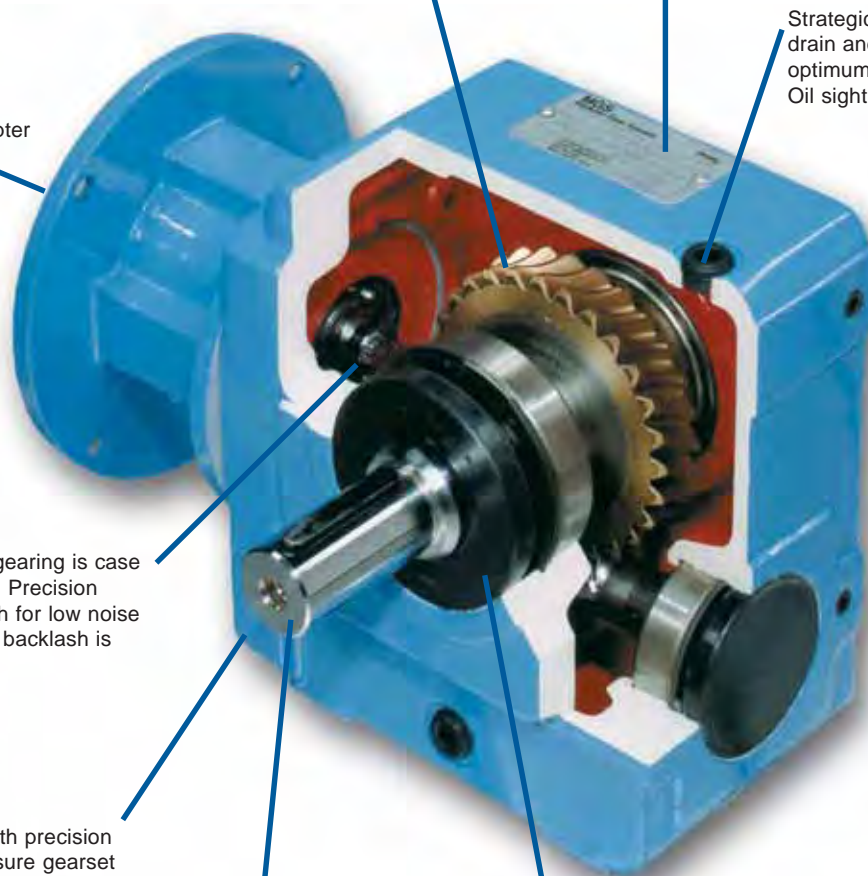

High quality first stage helical gearing is case hardened to 58-62 Rockwell C. Precision finished with minimum backlash for low noise and long service life. Standard backlash is  $\leq 20$  arc minutes

One-piece cast iron housing with precision machined bearing supports assure gearset alignment, prolongs bearing life, provides exceptional overhung load capacities, and eliminates leakage problems common to drives with bolt-on output covers.

**Output Options:**

- Solid shaft
- Hollow

Double lip seals keep oil in and contaminants out. Double seals available for severe duty applications

Shipped with the proper amount and type of oil to prevent gear damaging dry start-ups

SERIES





# "S" Series – Right Angle Helical/Worm MGS Speed Reducers Overview

**Output Style + Housing Style + Input Style = Reducer Configurations**

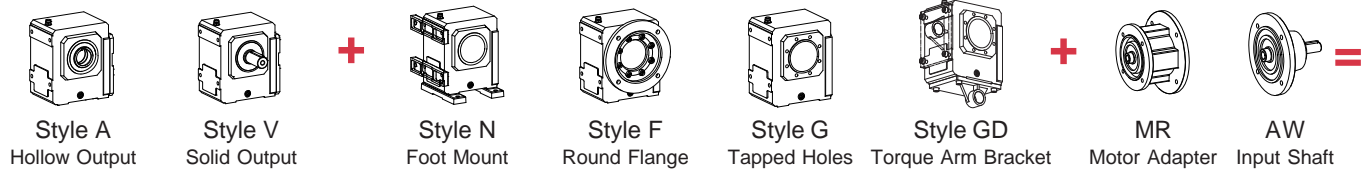

**Reducer Configurations** (See Page 170 for AW Input Shaft.)

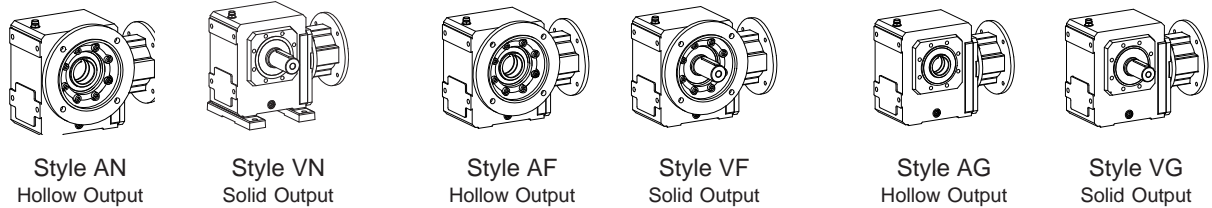

**Mounting Positions (Units shown with shaft on Side 4.)**

**Mounting Position MUST BE SPECIFIED.** (See Page 180 for more details.)  
 Standard Oil: Mobile XP600  
 Optional Oil: Food Grade Oil (Exxon Unisvis Special Mist 220)  
 Synthetic Oil (Mobil SHC630)

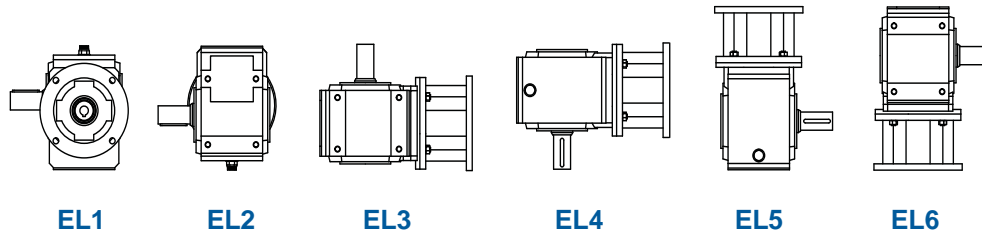

**Part No. Explanation with OPTIONS and REQUIRED INFORMATION**

**S 4 0 2 A N 0280 MR200 / 180**

050 (56C), 140 (143/145TC), **180** (182/184TC), 210 (213/215TC),  
 Motor Adapter Size: MR140, MR160, **MR200**, MR250  
 Nominal Ratio: (**0280** = 27.9:1)  
 HOUSING STYLE: "F" Housing Style – Flange Mounting – **SPECIFY IN A NOTE**: Flange on Side 3 or Side 4  
 "G" Housing Style – Tapped Holes  
 "GD" Housing Style – Torque Arm Bracket – **SPECIFY IN A NOTE**: Bracket on Side 1 or Side 5  
 "N" Housing Style – Foot Mount – **SPECIFY IN A NOTE**: Feet on Side 1 or Side 5  
 OUTPUT STYLE: "A" Hollow Output – **SPECIFY IN A NOTE**: Imperial or Metric<sup>1)</sup>  
 "V" Solid Output – **SPECIFY IN A NOTE**: Imperial or Metric<sup>1)</sup>: Single or Double  
 IF Single: Shaft on Side 3 or Side 4  
 No. of Stages (2 = 2 Stage, determined by ratio)  
 Design Generation  
 Unit Size No.  
 Right Angle Helical/Worm

**THE FOLLOWING INFORMATION IS REQUIRED FOR ANY UNIT:**

- Mounting Position – EL1 EL2 EL3 EL4 EL5 EL6
- Paint – Standard Gray, White, Stainless
- <sup>1)</sup> – Not available in all sizes.



# "S" Series – Right Angle Helical/Worm MGS Reducer – Selection Data



### Selection Procedure:

- Under the Input RPM heading, find **Approximate Output RPM** nearest the requirement.
- In the **Input HP** column locate the rating that is greater than or equal to the required HP.  
(If selection is based on Torque instead of HP, find an **Output Torque** that is equal to or greater than required.)
- When HP or Torque rating is located, read across that row to select the **Base Module**, **Input Option** and **Overhung Loads**.
- If exact **Output RPM** is required, divide the **Input RPM** by the **Exact Ratio**.

1750 RPM Input		Base Module <sup>1)</sup>	Input Options <sup>2)</sup>			Exact Ratio	Overhung Load Output Shaft <sup>3)</sup> lbs.	1450 RPM Input		1160 RPM Input		870 RPM Input	
Input HP	Output Torque in. lbs.		Motor Adapter	NEMA C-Frame Size <sup>4)</sup>	Input Shaft			Input HP	Output Torque in. lbs.	Input HP	Output Torque in. lbs.	Input HP	Output Torque in. lbs.

190 RPM Output (Approximate)								155 RPM		125 RPM		95 RPM	
1.78	511	S102_0092	MR140/050	56C	AW140/010	9.200	593	1.69	589	1.60	684	1.37	777
1.78	511	S102_0092	MR160/050	56C	AW160/012	9.200	593	1.69	589	1.60	684	1.37	777
1.78	511	S102_0092	MR160/140	143/145TC	AW160/012	9.200	593	1.69	589	1.60	684	1.37	777
3.26	939	S202_0092	MR140/050	56C	AW140/010	9.232	862	2.67	933	2.16	928	1.62	921
3.47	998	S202_0092	MR160/050	56C	AW160/012	9.232	862	3.27	1,145	3.08	1,320	2.79	1,585
3.47	998	S202_0092	MR160/140	143/145TC	AW160/012	9.232	862	3.27	1,145	3.08	1,320	2.79	1,585
3.47	998	S202_0092	MR200/180	182/184TC	AW200/014	9.232	862	3.27	1,145	3.08	1,320	2.79	1,585
5.17	1,499	S302_0093	MR160/050	56C	AW160/012	9.310	1,078	5.20	1,834	4.25	1,836	3.18	1,822
5.17	1,499	S302_0093	MR160/140	143/145TC	AW160/012	9.310	1,078	5.20	1,834	4.25	1,836	3.18	1,822
5.17	1,499	S302_0093	MR200/180	182/184TC	AW200/014	9.310	1,078	5.20	1,834	5.23	2,261	4.68	2,680
8.19	2,382	S402_0093	MR160/050	56C	AW160/012	9.281	1,402	8.12	2,874	8.05	3,491	7.38	4,234
8.19	2,382	S402_0093	MR160/140	143/145TC	AW160/012	9.281	1,402	8.12	2,874	8.05	3,491	7.38	4,234
8.19	2,382	S402_0093	MR200/180	182/184TC	AW200/014	9.281	1,402	8.12	2,874	8.05	3,491	7.38	4,234
8.19	2,382	S402_0093	MR250/210	213/215TC	AW250/102	9.281	1,402	8.12	2,874	8.05	3,491	7.38	4,234

150 RPM Output (Approximate)								125 RPM		100 RPM		75 RPM	
1.68	598	S102_0115	MR140/050	56C	AW140/010	11.500	627	1.59	691	1.43	760	1.19	837
1.68	598	S102_0115	MR160/050	56C	AW160/012	11.500	627	1.59	691	1.43	760	1.19	837
1.68	598	S102_0115	MR160/140	143/145TC	AW160/012	11.500	627	1.59	691	1.43	760	1.19	837
3.16	1,131	S202_0115	MR140/050	56C	AW140/010	11.600	912	2.58	1,125	2.10	1,118	1.57	1,110
3.26	1,165	S202_0115	MR160/050	56C	AW160/012	11.600	912	3.07	1,337	2.89	1,541	2.42	1,710
3.26	1,165	S202_0115	MR160/140	143/145TC	AW160/012	11.600	912	3.07	1,337	2.89	1,541	2.42	1,710
3.26	1,165	S202_0115	MR200/180	182/184TC	AW200/014	11.600	912	3.07	1,337	2.89	1,541	2.42	1,710
5.20	1,877	S302_0115	MR160/050	56C	AW160/012	11.660	1,141	5.06	2,219	4.10	2,207	3.08	2,191
5.20	1,877	S302_0115	MR160/140	143/145TC	AW160/012	11.660	1,141	5.23	2,298	4.88	2,625	4.06	2,889
8.08	2,924	S402_0115	MR160/050	56C	AW160/012	11.570	1,483	8.01	3,528	7.67	4,141	6.38	4,557
8.08	2,924	S402_0115	MR160/140	143/145TC	AW160/012	11.570	1,483	8.01	3,528	7.67	4,141	6.38	4,557
8.08	2,924	S402_0115	MR200/180	182/184TC	AW200/014	11.570	1,483	8.01	3,528	7.67	4,141	6.38	4,557
8.08	2,924	S402_0115	MR250/210	213/215TC	AW250/102	11.570	1,483	8.01	3,528	7.67	4,141	6.38	4,557

125 RPM Output (Approximate) Continued Next Page								100 RPM		80 RPM		60 RPM	
1.61	689	S102_0140	MR140/050	56C	AW140/010	14.040	657	1.45	758	1.27	812	1.06	894
1.61	689	S102_0140	MR160/050	56C	AW160/012	14.040	657	1.45	758	1.27	812	1.06	894
1.61	689	S102_0140	MR160/140	143/145TC	AW160/012	14.040	657	1.45	758	1.27	812	1.06	894
3.04	1,307	S202_0140	MR140/050	56C	AW140/010	13.910	956	2.48	1,299	2.01	1,292	1.51	1,283
3.07	1,319	S202_0140	MR160/050	56C	AW160/012	13.910	956	2.89	1,513	2.57	1,651	2.14	1,817
3.07	1,319	S202_0140	MR160/140	143/145TC	AW160/012	13.910	956	2.89	1,513	2.57	1,651	2.14	1,817
3.07	1,319	S202_0140	MR200/180	182/184TC	AW200/014	13.910	956	2.89	1,513	2.57	1,651	2.14	1,817
5.20	2,253	S302_0140	MR160/050	56C	AW160/012	14.000	1,196	4.86	2,563	3.94	2,549	2.96	2,532
5.20	2,253	S302_0140	MR160/140	143/145TC	AW160/012	14.000	1,196	4.86	2,563	3.94	2,549	2.96	2,532

For thermal HP capacity, see rating below.

Base Module	S1	S2	S3	S4
Thermal Capacity	2.95	5.36	7.38	12.34

### Housing Styles

- N – Foot Mounted    F – Round Flange    G – Tapped Holes    GD – Torque Arm Bracket

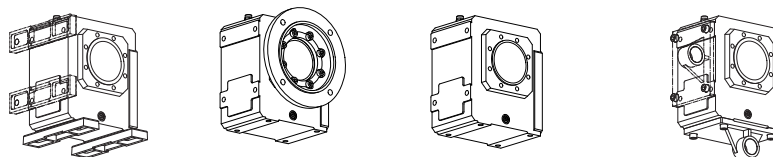

These Housing Styles are available as Hollow (A) or Solid (V) Output.

NEMA Frame Size  
TEFC 1750 RPM

C-Frame	Motor HP
56C	1/3 - 1 1/2
143T/145T	1, 1 1/2, 2
182T/184T	3, 5
213T/215T	7 1/2, 10



# "S" Series – Right Angle Helical/Worm MGS Reducer – Selection Data



- NOTE:** 1) Complete Base Module Part Number by adding Output and Housing Style. Example: S302VG0560.  
 2) Select Input Option and add to completed Part Number. See example below.  
 3) Overhung Load is measured at the center of the shaft extension. Hollow output units are not intended to support overhung loads. If a load rating is required, use 50% of the published overhung load.  
 4) Other frame sizes may also be available. See dimension pages.

1750 RPM Input		Base Module <sup>1)</sup>	Input Options <sup>2)</sup>			Exact Ratio	Overhung Load Output Shaft <sup>3)</sup> lbs.	1450 RPM Input		1160 RPM Input		870 RPM Input	
Input HP	Output Torque in. lbs.		Motor Adapter	NEMA C-Frame Size <sup>4)</sup>	Input Shaft			Input HP	Output Torque in. lbs.	Input HP	Output Torque in. lbs.	Input HP	Output Torque in. lbs.
<b>125 RPM Output (Approximate) Continued</b>													
								<b>100 RPM</b>		<b>80 RPM</b>		<b>60 RPM</b>	
5.20	2,253	S302_0140	MR200/180	182/184TC	AW160/012	14.000	1,196	4.93	2,602	4.31	2,790	3.59	3,070
8.00	3,479	S402_0140	MR160/050	56C	AW160/012	13.950	1,554	7.77	4,110	6.79	4,407	5.65	4,851
8.00	3,479	S402_0140	MR160/140	143/145TC	AW160/012	13.950	1,554	7.77	4,110	6.79	4,407	5.65	4,851
8.00	3,479	S402_0140	MR200/180	182/184TC	AW200/014	13.950	1,554	7.77	4,110	6.79	4,407	5.65	4,851
8.00	3,479	S402_0140	MR250/210	213/215TC	AW250/102	13.950	1,554	7.77	4,110	6.79	4,407	5.65	4,851
<b>100 RPM Output (Approximate)</b>													
								<b>80 RPM</b>		<b>65 RPM</b>		<b>50 RPM</b>	
1.43	762	S102_0175	MR140/050	56C	AW140/010	17.470	695	1.26	815	1.10	874	0.91	962
1.43	762	S102_0175	MR160/050	56C	AW160/012	17.470	695	1.26	815	1.10	874	0.91	962
1.43	762	S102_0175	MR160/140	143/145TC	AW160/012	17.470	695	1.26	815	1.10	874	0.91	962
2.89	1,544	S202_0175	MR140/050	56C	AW140/010	17.550	1,011	2.41	1,567	1.96	1,559	1.47	1,549
2.89	1,544	S202_0175	MR160/050	56C	AW160/012	17.550	1,011	2.56	1,664	2.24	1,784	1.86	1,964
2.89	1,544	S202_0175	MR160/140	143/145TC	AW160/012	17.550	1,011	2.56	1,664	2.24	1,784	1.86	1,964
3.02	1,625	S302_0175	MR140/050	56C	AW140/010	17.370	1,264	2.46	1,617	2.00	1,608	1.50	1,598
4.85	2,614	S302_0175	MR160/050	56C	AW160/012	17.370	1,264	4.26	2,796	3.73	2,998	2.82	3,008
4.85	2,614	S302_0175	MR160/140	143/145TC	AW160/012	17.370	1,264	4.26	2,796	3.73	2,998	2.82	3,008
4.85	2,614	S302_0175	MR200/180	182/184TC	AW200/014	17.370	1,264	4.26	2,796	3.73	2,998	3.10	3,300
7.67	4,143	S402_0175	MR160/050	56C	AW160/012	17.490	1,644	6.74	4,432	5.89	4,752	4.90	5,230
7.67	4,143	S402_0175	MR160/140	143/145TC	AW160/012	17.490	1,644	6.74	4,432	5.89	4,752	4.90	5,230
7.67	4,143	S402_0175	MR200/180	182/184TC	AW200/014	17.490	1,644	6.74	4,432	5.89	4,752	4.90	5,230
7.67	4,143	S402_0175	MR250/210	213/215TC	AW250/102	17.490	1,644	6.74	4,432	5.89	4,752	4.90	5,230
<b>75 RPM Output (Approximate)</b>													
								<b>60 RPM</b>		<b>50 RPM</b>		<b>35 RPM</b>	
1.19	837	S102_0230	MR140/050	56C	AW140/010	23.140	747	1.04	895	0.91	960	0.75	1,056
1.19	837	S102_0230	MR160/050	56C	AW160/012	23.140	747	1.04	895	0.91	960	0.75	1,056
1.19	837	S102_0230	MR160/140	143/145TC	AW160/012	23.140	747	1.04	895	0.91	960	0.75	1,056
2.42	1,709	S202_0230	MR140/050	56C	AW140/010	23.290	1,087	2.12	1,828	1.85	1,954	1.39	1,943
2.42	1,709	S202_0230	MR160/050	56C	AW160/012	23.290	1,087	2.12	1,828	1.85	1,960	1.54	2,152
2.42	1,709	S202_0230	MR160/140	143/145TC	AW160/012	23.290	1,087	2.12	1,828	1.85	1,960	1.54	2,152
2.88	2,056	S302_0230	MR140/050	56C	AW140/010	23.400	1,359	2.36	2,046	1.91	2,037	1.43	2,025
4.05	2,887	S302_0230	MR160/050	56C	AW160/012	23.400	1,359	3.55	3,088	3.11	3,311	2.58	3,644
4.05	2,887	S302_0230	MR160/140	143/145TC	AW160/012	23.400	1,359	3.55	3,088	3.11	3,311	2.58	3,644
4.05	2,887	S302_0230	MR200/180	182/184TC	AW200/014	23.400	1,359	3.55	3,088	3.11	3,311	2.58	3,644
6.38	4,566	S402_0230	MR160/050	56C	AW160/012	23.400	1,767	5.61	4,883	4.90	5,236	4.07	5,763
6.38	4,566	S402_0230	MR160/140	143/145TC	AW160/012	23.400	1,767	5.61	4,883	4.90	5,236	4.07	5,763
6.38	4,566	S402_0230	MR200/180	182/184TC	AW200/014	23.400	1,767	5.61	4,883	4.90	5,236	4.07	5,763
6.38	4,566	S402_0230	MR250/180	182/184TC	AW250/102	23.400	1,767	5.61	4,883	4.90	5,236	4.07	5,763

### Part No. Explanation

S 3 0 2 V G 0590 AW 160 /012

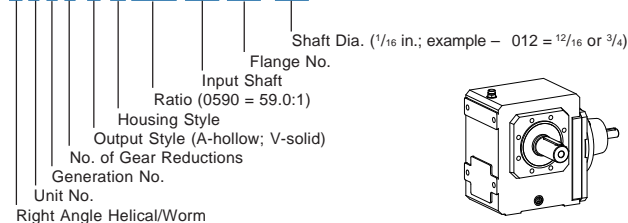

S 3 0 2 V G 0590 MR 160 /140

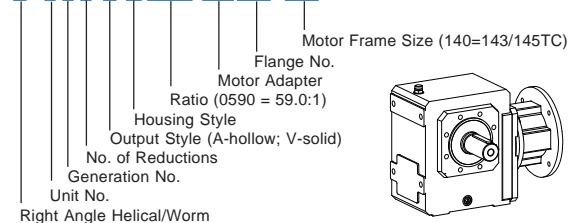

**Mounting position must be specified when ordering.**



# "S" Series – Right Angle Helical/Worm MGS Reducer – Selection Data



### Selection Procedure:

- Under the Input RPM heading, find **Approximate Output RPM** nearest the requirement.
- In the **Input HP** column locate the rating that is greater than or equal to the required HP.  
(If selection is based on Torque instead of HP, find an **Output Torque** that is equal to or greater than required.)
- When HP or Torque rating is located, read across that row to select the **Base Module**, **Input Option** and **Overhung Loads**.
- If exact **Output RPM** is required, divide the **Input RPM** by the **Exact Ratio**.

1750 RPM Input		Base Module <sup>1)</sup>	Input Options <sup>2)</sup>			Exact Ratio	Overhung Load Output Shaft <sup>3)</sup> lbs.	1450 RPM Input		1160 RPM Input		870 RPM Input	
Input HP	Output Torque in. lbs.		Motor Adapter	NEMA C-Frame Size <sup>4)</sup>	Input Shaft			Input HP	Output Torque in. lbs.	Input HP	Output Torque in. lbs.	Input HP	Output Torque in. lbs.
<b>60 RPM Output (Approximate)</b>													
1.06	890	S102_0280	MR140/050	56C	AW140/010	27.900	782	0.93	952	0.81	1,021	0.64	1,066
1.06	890	S102_0280	MR160/050	56C	AW160/012	27.900	782	0.93	952	0.81	1,021	0.64	1,066
1.06	890	S102_0280	MR160/140	143/145TC	AW160/012	27.900	782	0.93	952	0.81	1,021	0.64	1,066
2.15	1,819	S202_0280	MR140/050	56C	AW140/010	28.080	1,138	1.89	1,946	1.65	2,087	1.32	2,214
2.15	1,819	S202_0280	MR160/050	56C	AW160/012	28.080	1,138	1.89	1,946	1.65	2,087	1.32	2,214
2.15	1,819	S202_0280	MR160/140	143/145TC	AW160/012	28.080	1,138	1.89	1,946	1.65	2,087	1.32	2,214
2.78	2,369	S302_0280	MR140/050	56C	AW140/010	28.010	1,422	2.27	2,359	1.84	2,348	1.38	2,335
3.60	3,065	S302_0280	MR160/050	56C	AW160/012	28.010	1,422	3.16	3,278	2.76	3,515	2.29	3,869
3.60	3,065	S302_0280	MR160/140	143/145TC	AW160/012	28.010	1,422	3.16	3,278	2.76	3,515	2.29	3,869
3.60	3,065	S302_0280	MR200/180	182/184TC	AW200/014	28.010	1,422	3.16	3,278	2.76	3,515	2.29	3,869
5.39	4,610	S402_0280	MR160/050	56C	AW160/012	27.900	1,849	4.41	4,588	3.57	4,566	2.68	4,540
5.39	4,610	S402_0280	MR160/140	143/145TC	AW160/012	27.900	1,849	4.41	4,588	3.57	4,566	2.68	4,540
5.66	4,841	S402_0280	MR200/180	182/184TC	AW200/014	27.900	1,849	4.97	5,178	4.35	5,552	3.61	6,111
<b>50 RPM Output (Approximate)</b>													
0.92	960	S102_0350	MR140/050	56C	AW140/010	34.920	826	0.78	992	0.63	988	0.47	984
0.92	960	S102_0350	MR160/050	56C	AW160/012	34.920	826	0.78	992	0.63	988	0.47	984
1.86	1,953	S202_0350	MR140/050	56C	AW140/010	34.710	1,202	1.64	2,089	1.39	2,176	1.04	2,166
1.86	1,953	S202_0350	MR160/050	56C	AW160/012	34.710	1,202	1.64	2,089	1.39	2,176	1.04	2,166
1.86	1,953	S202_0350	MR160/140	143/145TC	AW160/012	34.710	1,202	1.64	2,089	1.39	2,176	1.04	2,166
2.67	2,820	S302_0350	MR140/050	56C	AW140/010	34.890	1,503	2.18	2,808	1.77	2,796	1.33	2,783
3.12	3,298	S302_0350	MR160/050	56C	AW160/012	34.890	1,503	2.74	3,527	2.27	3,591	1.70	3,573
3.12	3,298	S302_0350	MR160/140	143/145TC	AW160/012	34.890	1,503	2.74	3,527	2.27	3,591	1.70	3,573
4.92	5,217	S402_0350	MR160/050	56C	AW160/012	34.920	1,954	4.04	5,219	3.28	5,197	2.46	5,170
4.92	5,217	S402_0350	MR160/140	143/145TC	AW160/012	34.920	1,954	4.04	5,219	3.28	5,197	2.46	5,170
4.92	5,217	S402_0350	MR200/180	182/184TC	AW200/014	34.920	1,954	4.04	5,219	3.28	5,197	2.46	5,170
<b>40 RPM Output (Approximate)</b>													
0.82	995	S102_0440	MR140/050	56C	AW140/010	43.680	874	0.73	1,065	0.65	1,161	0.53	1,264
0.82	995	S102_0440	MR160/050	56C	AW160/012	43.680	874	0.73	1,065	0.65	1,161	0.53	1,264
1.42	1,751	S202_0440	MR140/050	56C	AW140/010	43.880	1,272	1.25	1,876	1.13	2,075	0.95	2,309
1.42	1,751	S202_0440	MR160/050	56C	AW160/012	43.880	1,272	1.25	1,876	1.13	2,075	0.95	2,309
1.42	1,751	S202_0440	MR160/140	143/145TC	AW160/012	43.880	1,272	1.25	1,876	1.13	2,075	0.95	2,309
2.63	3,301	S302_0430	MR160/050	56C	AW140/010	43.440	1,590	2.33	3,557	2.00	3,725	1.50	3,690
2.63	3,301	S302_0430	MR160/140	143/145TC	AW160/012	43.440	1,590	2.33	3,557	2.10	3,910	1.74	4,294
3.86	4,893	S402_0440	MR160/050	56C	AW160/012	43.710	2,067	3.43	5,267	3.08	5,799	2.57	6,386
3.86	4,893	S402_0440	MR160/140	143/145TC	AW160/012	43.710	2,067	3.43	5,267	3.08	5,799	2.57	6,386
3.86	4,893	S402_0440	MR200/180	182/184TC	AW200/014	43.710	2,067	3.43	5,267	3.08	5,799	2.57	6,386
3.86	4,893	S402_0440	MR250/180	182/184TC	AW250/102	43.710	2,067	3.43	5,267	3.08	5,799	2.57	6,386

For thermal HP capacity, see rating below.

Base Module	S1	S2	S3	S4
Thermal Capacity	2.95	5.36	7.38	12.34

### Housing Styles

N – Foot Mounted    F – Round Flange    G – Tapped Holes    GD – Torque Arm Bracket

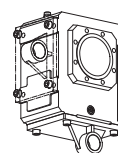
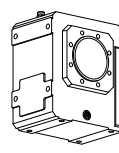
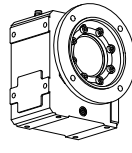
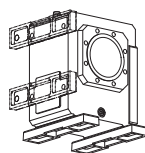

These Housing Styles are available as Hollow (A) or Solid (V) Output.

NEMA Frame Size  
TEFC 1750 RPM

C-Frame	Motor HP
56C	1/3 - 1 1/2
143T/145T	1, 1 1/2, 2
182T/184T	3, 5
213T/215T	7 1/2, 10





# "S" Series – Right Angle Helical/Worm MGS Reducer – Selection Data



- NOTE:** 1) Complete Base Module Part Number by adding Output and Housing Style. Example: S302VG0560.  
 2) Select Input Option and add to completed Part Number. See example below.  
 3) Overhung Load is measured at the center of the shaft extension. Hollow output units are not intended to support overhung loads. If a load rating is required, use 50% of the published overhung load.  
 4) Other frame sizes may also be available. See dimension pages.

1750 RPM Input		Base Module <sup>1)</sup>	Input Options <sup>2)</sup>			Exact Ratio	Overhung Load Output Shaft <sup>3)</sup> lbs.	1450 RPM Input		1160 RPM Input		870 RPM Input	
Input HP	Output Torque in. lbs.		Motor Adapter	NEMA C-Frame Size <sup>4)</sup>	Input Shaft			Input HP	Output Torque in. lbs.	Input HP	Output Torque in. lbs.	Input HP	Output Torque in. lbs.
<b>30 RPM Output (Approximate)</b>													
0.69	1,100	S102_0580	MR140/050	56C	AW140/010	57.860	940	0.61	1,189	0.53	1,261	0.43	1,339
0.69	1,100	S102_0580	MR160/140	56C	AW160/012	57.860	940	0.61	1,189	0.53	1,261	0.43	1,339
1.19	1,945	S202_0580	MR140/050	56C	AW140/010	58.220	1,367	1.08	2,141	0.95	2,306	0.77	2,482
1.19	1,945	S202_0580	MR160/050	56C	AW160/012	58.220	1,367	1.08	2,141	0.95	2,306	0.77	2,482
1.19	1,945	S202_0580	MR160/140	143/145TC	AW160/012	58.220	1,367	1.08	2,141	0.95	2,306	0.77	2,482
2.25	3,725	S302_0590	MR140/050	56C	AW140/010	58.500	1,709	2.01	4,040	1.75	4,306	1.41	4,591
2.25	3,725	S302_0590	MR160/050	56C	AW160/012	58.500	1,709	2.01	4,040	1.75	4,306	1.41	4,591
2.25	3,725	S302_0590	MR160/140	143/145TC	AW160/012	58.500	1,709	2.01	4,040	1.75	4,306	1.41	4,591
3.29	5,500	S402_0590	MR160/050	56C	AW160/012	58.500	2,222	2.95	5,984	2.57	6,393	2.08	6,832
3.29	5,500	S402_0590	MR160/140	143/145TC	AW160/012	58.500	2,222	2.95	5,984	2.57	6,393	2.08	6,832
3.29	5,500	S402_0590	MR200/180	182/184TC	AW200/014	58.500	2,222	2.95	5,984	2.57	6,393	2.08	6,832
3.29	5,500	S402_0590	MR250/180	182/184TC	AW250/102	58.500	2,222	2.95	5,984	2.57	6,393	2.08	6,832
<b>25 RPM Output (Approximate)</b>													
0.62	1,183	S102_0700	MR140/050	56C	AW140/010	69.750	983	0.54	1,254	0.46	1,314	0.37	1,379
0.62	1,183	S102_0700	MR160/050	56C	AW160/012	69.750	983	0.54	1,254	0.46	1,314	0.37	1,379
1.09	2,128	S202_0700	MR140/050	56C	AW140/010	70.200	1,431	0.97	2,290	0.84	2,426	0.67	2,573
1.09	2,128	S202_0700	MR160/050	56C	AW160/012	70.200	1,431	0.97	2,290	0.84	2,426	0.67	2,573
1.09	2,128	S202_0700	MR160/140	143/145TC	AW160/012	70.200	1,431	0.97	2,290	0.84	2,426	0.67	2,573
2.03	4,009	S302_0700	MR140/050	56C	AW140/010	70.030	1,789	1.78	4,272	1.53	4,494	1.22	4,732
2.03	4,009	S302_0700	MR160/050	56C	AW160/012	70.030	1,789	1.78	4,272	1.53	4,494	1.22	4,732
2.03	4,009	S302_0700	MR160/140	143/145TC	AW160/012	70.030	1,789	1.78	4,272	1.53	4,494	1.22	4,732
2.97	5,927	S402_0700	MR160/050	56C	AW160/012	69.750	2,325	2.61	6,333	2.25	6,676	1.79	7,044
2.97	5,927	S402_0700	MR160/140	143/145TC	AW160/012	69.750	2,325	2.61	6,333	2.25	6,676	1.79	7,044
<b>20 RPM Output (Approximate)</b>													
0.54	1,262	S102_0870	MR140/050	56C	AW140/010	87.300	1,039	0.46	1,318	0.39	1,366	0.31	1,417
0.54	1,262	S102_0870	MR160/050	56C	AW160/012	87.300	1,039	0.46	1,318	0.39	1,366	0.31	1,417
0.95	2,297	S202_0870	MR140/050	56C	AW140/010	86.790	1,512	0.83	2,428	0.71	2,538	0.56	2,657
0.95	2,297	S202_0870	MR160/050	56C	AW160/012	86.790	1,512	0.83	2,428	0.71	2,538	0.56	2,657
1.76	4,293	S302_0870	MR140/050	56C	AW140/010	87.230	1,890	1.52	4,504	1.29	4,682	1.01	4,872
1.76	4,293	S302_0870	MR160/050	56C	AW160/012	87.230	1,890	1.52	4,504	1.29	4,682	1.01	4,872
1.76	4,293	S302_0870	MR160/140	143/145TC	AW160/012	87.230	1,890	1.52	4,504	1.29	4,682	1.01	4,872
2.59	6,374	S402_0870	MR160/050	56C	AW160/012	87.300	2,457	2.23	6,698	1.90	6,972	1.46	7,086
2.59	6,374	S402_0870	MR160/140	143/145TC	AW160/012	87.300	2,457	2.23	6,698	1.90	6,972	1.46	7,086

### Part No. Explanation

S 3 0 2 V G 0590 AW 160 /012

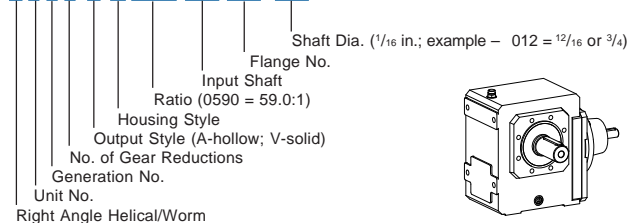

S 3 0 2 V G 0590 MR 160 /140

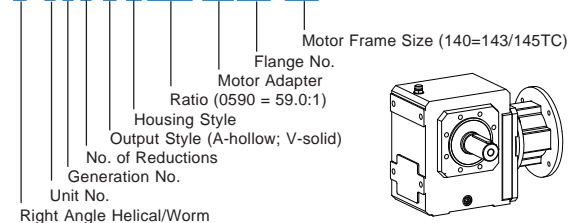

**Mounting position must be specified when ordering.**



# "S" Series – Right Angle Helical/Worm MGS Reducer – Selection Data



### Selection Procedure:

- Under the Input RPM heading, find **Approximate Output RPM** nearest the requirement.
- In the **Input HP** column locate the rating that is greater than or equal to the required HP.  
(If selection is based on Torque instead of HP, find an **Output Torque** that is equal to or greater than required.)
- When HP or Torque rating is located, read across that row to select the **Base Module**, **Input Option** and **Overhung Loads**.
- If exact **Output RPM** is required, divide the **Input RPM** by the **Exact Ratio**.

1750 RPM Input		Base Module <sup>1)</sup>	Input Options <sup>2)</sup>			Exact Ratio	Overhung Load Output Shaft <sup>3)</sup> lbs.	1450 RPM Input		1160 RPM Input		870 RPM Input	
Input HP	Output Torque in. lbs.		Motor Adapter	NEMA C-Frame Size <sup>4)</sup>	Input Shaft			Input HP	Output Torque in. lbs.	Input HP	Output Torque in. lbs.	Input HP	Output Torque in. lbs.
<b>15 RPM Output (Approximate)</b>													
0.43	1,340	S102_1170	MR140/050	56C	AW140/010	116.700	1,117	0.37	1,382	0.31	1,417	0.23	1,417
0.78	2,478	S202_1160	MR140/050	56C	AW140/010	116.100	1,625	0.66	2,575	0.56	2,657	0.42	2,657
0.78	2,478	S202_1160	MR160/140	56C	AW160/012	116.100	1,625	0.66	2,575	0.56	2,657	0.42	2,657
1.42	4,580	S302_1160	MR140/050	56C	AW140/010	116.100	2,031	1.21	4,738	1.01	4,872	0.76	4,872
1.42	4,580	S302_1160	MR160/050	56C	AW160/012	116.100	2,031	1.21	4,738	1.01	4,872	0.76	4,872
1.42	4,580	S302_1160	MR160/140	143/145TC	AW160/012	116.100	2,031	1.21	4,738	1.01	4,872	0.76	4,872
2.09	6,817	S402_1160	MR160/050	56C	AW160/012	116.300	2,640	1.78	7,060	1.46	7,086	1.10	7,086
2.09	6,817	S402_1160	MR160/140	143/145TC	AW160/012	116.300	2,640	1.78	7,060	1.46	7,086	1.10	7,086
<b>12 RPM Output (Approximate)</b>													
0.38	1,378	S102_1400	MR140/050	56C	AW140/010	139.500	1,164	0.32	1,407	0.26	1,401	0.19	1,394
0.68	2,557	S203_1360	MR140/050	56C	AW140/010	136.300	1,693	0.58	2,640	0.47	2,657	0.36	2,657
0.69	2,567	S202_1400	MR140/050	56C	AW140/010	139.500	1,693	0.58	2,649	0.47	2,657	0.36	2,657
1.13	4,281	S303_1370	MR140/050	56C	AW140/010	137.100	2,117	0.92	4,260	0.75	4,241	0.56	4,218
1.21	4,584	S302_1400	MR140/050	56C	AW140/010	139.900	2,117	0.99	4,562	0.80	4,542	0.60	4,517
1.21	4,584	S302_1400	MR160/050	56C	AW160/012	139.900	2,117	0.99	4,562	0.80	4,542	0.60	4,517
1.21	4,584	S302_1400	MR160/140	143/145TC	AW160/012	139.900	2,117	0.99	4,562	0.80	4,542	0.60	4,517
1.24	4,703	S303_1350	MR160/050	56C	AW160/012	135.300	2,117	1.05	4,839	0.86	4,872	0.65	4,872
1.24	4,703	S303_1350	MR160/140	143/145TC	AW160/012	135.300	2,117	1.05	4,839	0.86	4,872	0.65	4,872
1.83	7,000	S403_1350	MR160/050	56C	AW160/012	134.900	2,752	1.52	7,086	1.24	7,086	0.93	7,086
1.83	7,000	S403_1350	MR160/140	143/145TC	AW160/012	134.900	2,752	1.52	7,086	1.24	7,086	0.93	7,086
1.84	7,041	S402_1400	MR160/050	56C	AW160/012	139.900	2,752	1.52	7,086	1.24	7,086	0.93	7,086
1.84	7,041	S402_1400	MR160/140	143/145TC	AW160/012	139.900	2,752	1.52	7,086	1.24	7,086	0.93	7,086
<b>10 RPM Output (Approximate)</b>													
0.25	1,143	S102_1740	MR140/050	56C	AW140/010	174.100	1,230	0.21	1,138	0.17	1,134	0.13	1,129
0.49	2,251	S202_1740	MR140/050	56C	AW140/010	174.400	1,789	0.40	2,242	0.32	2,234	0.24	2,224
0.57	2,651	S203_1720	MR140/050	56C	AW140/010	171.800	1,789	0.47	2,657	0.38	2,657	0.29	2,657
0.78	3,648	S302_1740	MR140/050	56C	AW140/010	174.400	2,236	0.63	3,633	0.51	3,618	0.39	3,601
1.03	4,848	S303_1680	MR160/050	56C	AW160/012	167.900	2,236	0.85	4,872	0.69	4,872	0.52	4,872
1.03	4,848	S303_1680	MR160/140	143/145TC	AW160/012	167.900	2,236	0.85	4,872	0.69	4,872	0.52	4,872
1.03	4,855	S303_1700	MR140/050	56C	AW140/010	170.100	2,236	0.85	4,872	0.69	4,872	0.52	4,872
1.13	5,367	S403_1710	MR140/050	56C	AW140/010	171.200	2,907	0.92	5,343	0.75	5,321	0.56	5,295
1.36	6,443	S402_1740	MR160/050	56C	AW160/012	174.100	2,907	1.11	6,415	0.90	6,388	0.68	6,357
1.36	6,443	S402_1740	MR160/140	143/145TC	AW160/012	174.100	2,907	1.11	6,415	0.90	6,388	0.68	6,357
1.49	7,086	S403_1690	MR160/050	56C	AW160/012	169.000	2,907	1.23	7,086	1.00	7,086	0.75	7,086
1.49	7,086	S403_1690	MR160/140	143/145TC	AW160/012	169.000	2,907	1.23	7,086	1.00	7,086	0.75	7,086
<b>7 RPM Output (Approximate) Continued Next Page</b>													
0.26	1,253	S102_2420	MR140/050	56C	AW140/010	242.000	1,237	0.22	1,306	0.19	1,350	0.15	1,398
0.43	2,657	S203_2280	MR140/050	56C	AW140/010	228.000	1,800	0.35	2,657	0.29	2,657	0.22	2,657
0.78	4,872	S303_2290	MR140/050	56C	AW140/010	229.100	2,250	0.64	4,872	0.52	4,872	0.39	4,872

For thermal HP capacity, see rating below.

Base Module	S1	S2	S3	S4
Thermal Capacity	2.95	5.36	7.38	12.34

### Housing Styles

N – Foot Mounted    F – Round Flange    G – Tapped Holes    GD – Torque Arm Bracket

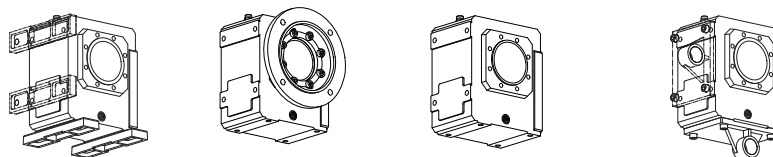

These Housing Styles are available as Hollow (A) or Solid (V) Output.

NEMA Frame Size  
TEFC 1750 RPM

C-Frame	Motor HP
56C	1/3 - 1 1/2
143T/145T	1, 1 1/2, 2
182T/184T	3, 5
213T/215T	7 1/2, 10



# "S" Series – Right Angle Helical/Worm MGS Reducer – Selection Data



- NOTE:** 1) Complete Base Module Part Number by adding Output and Housing Style. Example: S302VG0560.  
 2) Select Input Option and add to completed Part Number. See example below.  
 3) Overhung Load is measured at the center of the shaft extension. Hollow output units are not intended to support overhung loads. If a load rating is required, use 50% of the published overhung load.  
 4) Other frame sizes may also be available. See dimension pages.

1750 RPM Input		Base Module <sup>1)</sup>	Input Options <sup>2)</sup>			Exact Ratio	Overhung Load Output Shaft <sup>3)</sup> lbs.	1450 RPM Input		1160 RPM Input		870 RPM Input	
Input HP	Output Torque in. lbs.		Motor Adapter	NEMA C-Frame Size <sup>4)</sup>	Input Shaft			Input HP	Output Torque in. lbs.	Input HP	Output Torque in. lbs.	Input HP	Output Torque in. lbs.
<b>7 RPM Output (Approximate) Continued</b>													
0.78	4,872	S303_2260	MR160/050	56C	AW160/012	226.200	2,250	0.64	4,872	0.52	4,872	0.39	4,872
1.12	7,086	S403_2290	MR140/050	56C	AW140/010	229.100	2,925	0.92	7,086	0.75	7,085	0.56	7,056
1.12	7,086	S403_2260	MR160/050	56C	AW160/012	226.200	2,925	0.92	7,086	0.75	7,086	0.56	7,086
1.12	7,086	S403_2260	MR160/140	143/145TC	AW160/012	226.200	2,925	0.92	7,086	0.75	7,086	0.56	7,086
<b>6 RPM Output (Approximate)</b>													
0.22	1,300	S102_2890	MR140/050	56C	AW140/010	289.300	1,237	0.19	1,344	0.16	1,381	0.12	1,417
0.36	2,657	S203_2750	MR140/050	56C	AW140/010	275.000	1,800	0.30	2,657	0.24	2,657	0.18	2,657
0.65	4,872	S303_2740	MR140/050	56C	AW140/010	274.300	2,250	0.54	4,872	0.44	4,872	0.33	4,872
0.65	4,872	S303_2710	MR160/050	56C	AW160/012	270.800	2,250	0.54	4,872	0.44	4,872	0.33	4,872
0.94	7,086	S403_2730	MR140/050	56C	AW140/010	273.200	2,925	0.77	7,086	0.63	7,086	0.47	7,086
0.94	7,086	S403_2700	MR160/050	56C	AW160/012	269.700	2,925	0.77	7,086	0.63	7,086	0.47	7,086
<b>5 RPM Output (Approximate)</b>													
0.19	1,348	S102_3610	MR140/050	56C	AW140/010	361.200	1,237	0.16	1,383	0.13	1,413	0.10	1,417
0.29	2,657	S203_3400	MR140/050	56C	AW140/010	339.900	1,800	0.24	2,657	0.19	2,657	0.15	2,657
0.53	4,872	S303_3370	MR160/050	56C	AW160/012	337.300	2,250	0.43	4,872	0.35	4,872	0.26	4,872
0.53	4,872	S303_3420	MR140/050	56C	AW140/010	341.700	2,250	0.43	4,872	0.35	4,872	0.26	4,872
0.76	7,086	S403_3380	MR160/050	56C	AW160/012	337.600	2,925	0.62	7,086	0.51	7,086	0.38	7,086
0.76	7,086	S403_3420	MR140/050	56C	AW140/010	341.900	2,925	0.62	7,086	0.51	7,086	0.38	7,086
<b>4 RPM Output (Approximate)</b>													
0.22	2,657	S203_4550	MR140/050	56C	AW140/010	454.700	1,800	0.18	2,657	0.15	2,657	0.11	2,657
0.40	4,872	S303_4550	MR140/050	56C	AW140/010	454.700	2,250	0.33	4,872	0.26	4,872	0.20	4,872
0.40	4,872	S303_4490	MR160/050	56C	AW160/012	448.900	2,250	0.33	4,872	0.26	4,872	0.20	4,872
0.57	7,086	S403_4560	MR140/050	56C	AW140/010	455.500	2,925	0.47	7,086	0.38	7,086	0.29	7,086
0.57	7,086	S403_4500	MR160/050	56C	AW160/012	449.700	2,925	0.47	7,086	0.38	7,086	0.29	7,086
<b>3 RPM Output (Approximate)</b>													
0.18	2,655	S203_5460	MR140/050	56C	AW140/010	546.400	1,800	0.15	2,650	0.12	2,645	0.09	2,640
0.30	4,475	S303_5480	MR140/050	56C	AW140/010	548.000	2,250	0.25	4,465	0.20	4,457	0.15	4,447
0.48	7,086	S403_5410	MR160/050	56C	AW160/012	541.000	2,925	0.39	7,086	0.32	7,086	0.24	7,086
0.48	7,086	S403_5480	MR140/050	56C	AW140/010	548.000	2,925	0.39	7,086	0.32	7,086	0.24	7,086
<b>2.5 RPM Output (Approximate)</b>													
0.12	2,208	S203_6830	MR140/050	56C	AW140/010	683.000	1,800	0.10	2,204	0.08	2,201	0.06	2,197
0.19	3,572	S303_6830	MR140/050	56C	AW140/010	683.000	2,250	0.16	3,565	0.13	3,559	0.10	3,552
0.34	6,303	S403_6820	MR140/050	56C	AW140/010	682.100	2,925	0.28	6,291	0.23	6,280	0.17	6,268

**NOTE: For slower speeds than those listed above, units can be combined. Contact STÖBER Drives Inc.**

### Part No. Explanation

S 3 0 2 V G 0590 AW 160 / 012

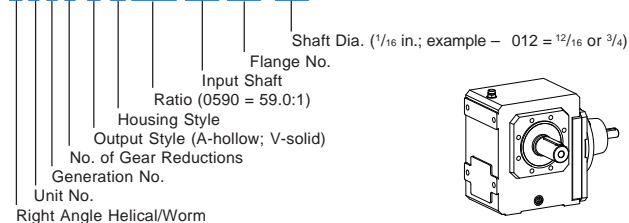

S 3 0 2 V G 0590 MR 160 / 140

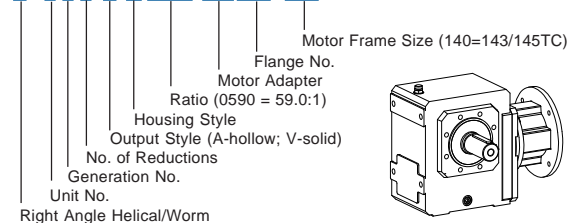

**Mounting position must be specified when ordering.**







# "S" Series – MGS Reducer Flange Mount – "F" Housing Shaft Output – Dimensional Data

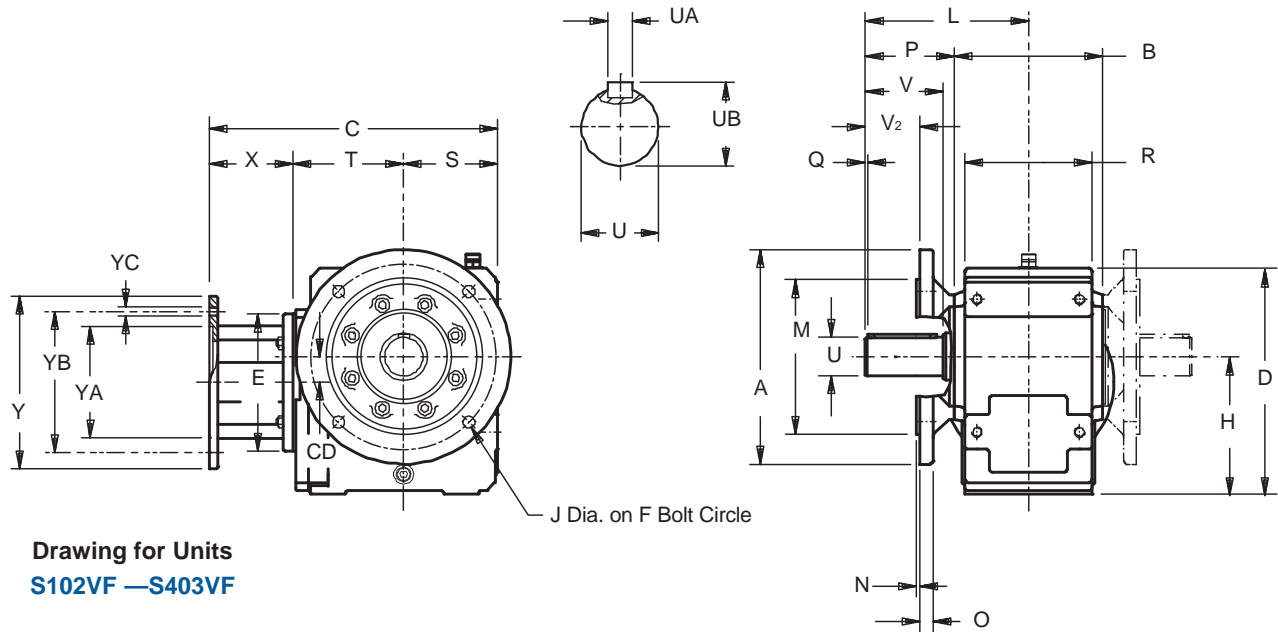
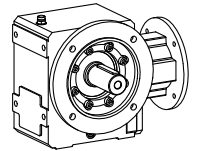

Drawing for Units  
S102VF —S403VF

Table No. 1 "S" Series – Round Flange Unit Dimensions (Inches) – "F" Housing Style

Base Module	A	B	D	F	H	J	L	M	N	O	P	Q	R	S	V	V <sub>2</sub>
<b>S102</b>	6.30	4.17	6.57	5.12	3.94	.35	4.53	4.331	.14	.39	2.44	.16	3.54	2.76	1.97	1.18
<b>S202/203</b>	7.87	5.28	7.87	6.50	4.72	.43	5.43	5.118	.14	.55	2.80	.16	4.53	3.35	2.36	1.30
<b>S302/303</b>	9.84	6.02	9.17	8.46	5.51	.55	6.69	7.087	.16	.59	3.68	.16	5.12	3.94	3.15	2.11
<b>S402/403</b>	9.84	6.81	10.35	8.46	6.30	.55	7.48	7.087	.16	.59	4.07	.16	5.83	4.33	3.54	2.52

Table No. 2 Metric output available on request.

Base Module	Standard Shaft - inches			Optional Shaft - mm		
	U	UA	UB	U	UA	UB
<b>S102</b>	1.000	1/4 x 1/4 x 1 1/2	1.11	25 <sub>k6</sub>	A8x7x40	28.0
<b>S202/203</b>	1.250	1/4 x 1/4 x 1 5/16	1.36	30 <sub>k6</sub>	A8x7x50	33.0
<b>S302/303</b>	1.375	5/16 x 5/16 x 2 5/16	1.51	40 <sub>k6</sub>	A12x8X70	43.0
<b>S402/403</b>	1.750	3/8 x 3/8 x 3 5/32	1.92	45 <sub>k6</sub>	A14x9x80	48.5

Table No. 3 Optional Flange Dimensions (Inches)

Base Module	Flange Size *	A	F	J	L	M	N	O
<b>S1</b>	<b>140</b>	5.512	4.53	.35	3.35	3.740	.12	.39
<b>S2</b>	<b>160</b>	6.300	5.12	.35	4.13	4.331	.14	.55

\* Optional flanges are not available in all sizes.

Table No. 4

"S" Series – Round Flange Unit Dimensions (Inches) – "F" Housing Style

Motor Adapter	NEMA C-Flange	E	X	Y	YA	YB	YC	Wt. lbs
<b>MR140/050</b>	56C	5.51	3.31	6.50	4.500	5.87	.41	9
<b>MR160/050</b>	56C	6.30	3.86	6.50	4.500	5.87	.41	16
<b>MR160/140</b>	143/145TC	6.30	3.86	6.50	4.500	5.87	.41	16
<b>MR200/180</b>	182/184TC	7.87	4.80	9.00	8.500	7.25	.55	23
<b>MR250/180</b>	182/184TC	9.84	5.31	9.00	8.500	7.25	.55	36
<b>MR250/210</b>	213/215TC	9.84	5.31	9.00	8.500	7.25	.55	36

Table No. 5 "S" Series– Round Flange Unit Dimensions (Inches) –"F" Housing Style

Base Module	MR140/050			MR160/140 <sup>1)</sup>			MR200/180			MR250/210 <sup>2)</sup>			Approx Wt. lbs.
	CD	C	T	CD	C	T	CD	C	T	CD	C	T	
<b>S102</b>	.55	9.34	3.27	.55	10.05	3.43	—	—	—	—	—	—	31
<b>S202</b>	.67	10.52	3.86	.67	11.23	4.02	.67	12.24	4.09	—	—	—	49
<b>S203</b>	.67	11.97	5.31	—	—	—	—	—	—	—	—	—	53
<b>S302</b>	1.00	11.70	4.45	1.00	12.41	4.61	1.00	13.43	4.69	—	—	—	60
<b>S303</b>	1.00	13.16	5.91	2.44	14.10	6.30	—	—	—	—	—	—	67
<b>S402</b>	—	—	—	1.18	13.27	5.08	1.18	14.29	5.16	1.18	14.88	5.24	80
<b>S403</b>	1.18	14.02	6.38	2.64	14.96	6.77	—	—	—	—	—	—	95

<sup>1)</sup> Also available as **MR160/050** for a NEMA 56C frame motor.

<sup>2)</sup> Also available as **MR250/180** for a NEMA 182/184TC frame motor.

All weights are approximate.

**Part No. Example**  
Round Flange with Motor Adapter  
**S302VF0620 MR160/140**

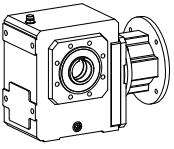

# "S" Series – MGS Reducer Tapped Holes – "G" Housing Hollow Output – Dimensional Data

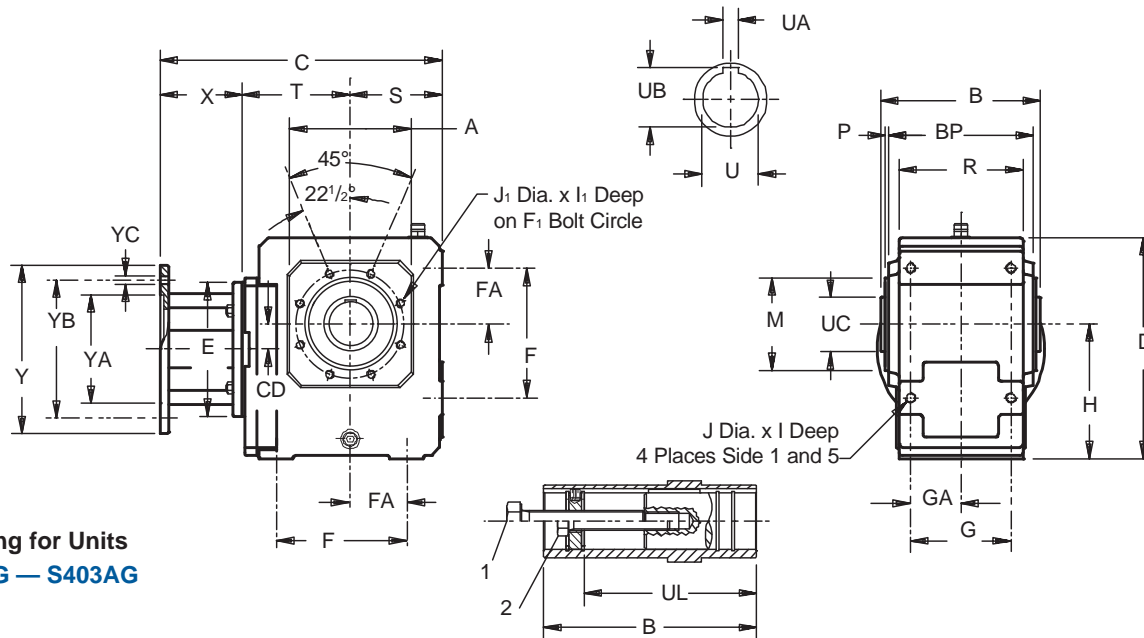

Drawing for Units  
S102AG – S403AG

Table No. 1 "S" Series – Tapped Holes Unit Dimensions (Inches) – "G" Housing Style

Base Module	A	B	D	F	F <sub>1</sub>	G	H	I	I <sub>1</sub>	J	J <sub>1</sub> <sup>1)</sup>	M	P	R	S	BP	FA	GA
<b>S102</b>	4.13	4.72	6.57	3.54	3.54	2.76	3.94	.51	.51	M8	M8	2.953	.12	3.54	2.76	4.17	1.57	1.38
<b>S202/203</b>	5.20	5.91	7.87	4.53	4.53	3.54	4.72	.63	.51	M10	M8	3.740	.16	4.53	3.35	5.28	2.05	1.77
<b>S302/303</b>	5.98	6.61	9.17	5.12	5.12	4.13	5.51	.63	.63	M10	M10	4.331	.14	5.12	3.94	6.02	2.05	2.05
<b>S402/403</b>	5.71	7.48	10.35	6.10	5.12	4.72	6.30	.75	.63	M12	M10	4.331	.14	5.83	4.33	6.81	2.64	2.36

<sup>1)</sup> S102 through S303 has 4 tapped holes instead of 8 as shown on drawing.

Table No. 2 Metric output available on request.

Base Module	Standard Bore - inches			Optional Bore - mm			UC	UL	1
	U	UA	UB	U	UA	UB			
<b>S102</b>	1.000	.250	1.11	25 <sub>H7</sub>	8 <sub>JS9</sub>	28.3	1.57	3.86	1/2-13
<b>S202/203</b>	1.375	.312	1.52	35 <sub>H7</sub>	10 <sub>JS9</sub>	38.3	1.97	4.69	5/8-11
<b>S302/303</b>	1.500	.375	1.67	40 <sub>H7</sub>	12 <sub>JS9</sub>	43.3	2.17	5.39	3/4-10
<b>S402/403</b>	1.750	.375	1.92	50 <sub>H7</sub>	14 <sub>JS9</sub>	53.8	2.56	6.24	3/4-10

1. Removal Bolt —not supplied.
2. Mounting Bolt —must be smaller than removal bolt.

### Part No. Example

Tapped Holes Housing with Motor  
Adapter

**S302AG0620 MR160/140**

Table No. 3

### "S" Series – Tapped Holes Unit Dimensions (Inches) – "G" Housing Style

Motor Adapter	NEMA C-Flange	E	X	Y	YA	YB	YC	Wt. lbs
<b>MR140/050</b>	56C	5.51	3.31	6.50	4.500	5.87	.41	9
<b>MR160/050</b>	56C	6.30	3.86	6.50	4.500	5.87	.41	16
<b>MR160/140</b>	143/145TC	6.30	3.86	6.50	4.500	5.87	.41	16
<b>MR200/180</b>	182/184TC	7.87	4.80	9.00	8.500	7.25	.55	23
<b>MR250/180</b>	182/184TC	9.84	5.31	9.00	8.500	7.25	.55	36
<b>MR250/210</b>	213/215TC	9.84	5.31	9.00	8.500	7.25	.55	36

Table No. 4 "S" Series – Tapped Holes Unit Dimensions (Inches) – "G" Housing Style

Base Module	MR140/050			MR160/140 <sup>2)</sup>			MR200/180			MR250/210 <sup>3)</sup>			Approx. Wt. lbs.
	CD	C	T	CD	C	T	CD	C	T	CD	C	T	
<b>S102</b>	.55	9.34	3.27	.55	10.05	3.43	—	—	—	—	—	—	31
<b>S202</b>	.67	10.52	3.86	.67	11.23	4.02	.67	12.24	4.09	—	—	—	49
<b>S203</b>	.67	11.97	5.31	—	—	—	—	—	—	—	—	—	53
<b>S302</b>	1.00	11.70	4.45	1.00	12.41	4.61	1.00	13.43	4.69	—	—	—	60
<b>S303</b>	1.00	13.16	5.91	2.44	14.10	6.30	—	—	—	—	—	—	67
<b>S402</b>	—	—	—	1.18	13.27	5.08	1.18	14.29	5.16	1.18	14.88	5.24	80
<b>S403</b>	1.18	14.02	6.38	2.64	14.96	6.77	—	—	—	—	—	—	95

<sup>2)</sup> Also available as **MR160/050** for a NEMA 56C frame motor.

<sup>3)</sup> Also available as **MR250/180** for a NEMA 182/184TC frame motor.

All weights are approximate.



# "S" Series – MGS Reducer Torque Arm Bracket – "GD" Housing (torque arm supplied by others)

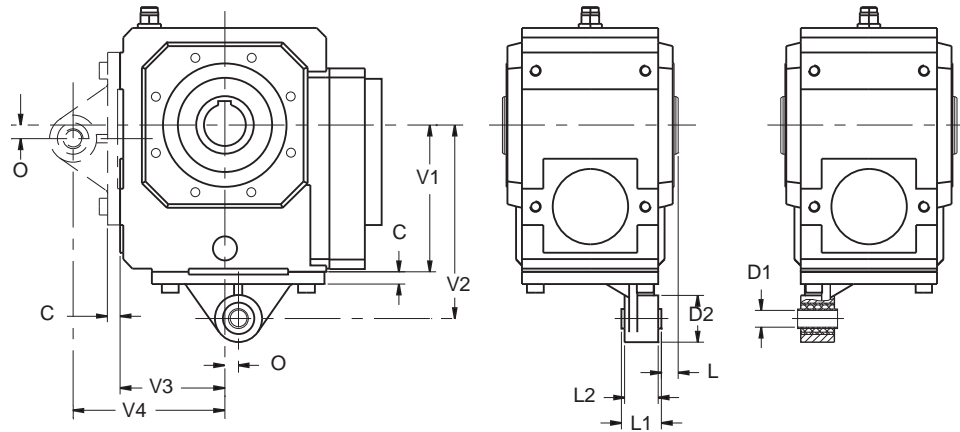
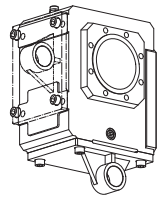

Table No. 1 "S" Series —Torque Arm Bracket Dimensions (Inches)

Base Module	C	D1	H9	D2	L	L1	L2	O	V1	V2	V3	V4
<b>S102</b>	.39	.47	+0.017/-0.000	1.69	.51	1.10	.94	.20	3.93	5.12	2.76	3.93
<b>S202/S203</b>	.47	.63	+0.017/-0.000	1.77	.57	1.50	1.26	.22	4.72	6.10	3.35	4.72
<b>S302/S303</b>	.47	.63	+0.017/-0.000	1.77	.63	1.50	1.26	.51	5.51	7.28	3.93	5.71
<b>S402/S403</b>	.55	.79	+0.020/-0.000	2.17	.71	1.81	1.57	.41	6.30	8.66	4.33	6.69

**Part No. Example**  
Unit with Torque Arm Bracket  
Hollow Output  
**S302AGD0620**





# Miscellaneous

## **VISION:**

To be recognized as the **Gold Standard** in our industry.

## **MISSION:**

To provide the most reliable and effective drive solutions for demanding applications in the shortest lead-time.

## **CORE VALUES:**

**Customer driven**  
**Value People**  
**Seek the Best**  
**Operate with Integrity**  
**Care and give back**



[www.stober.com](http://www.stober.com)



MEX (55) 53 63 23 31 MTY (81) 83 54 10 18  
QRO (442) 1 95 72 60 ventas@industrialmagza.com

# ComTrac<sup>®</sup> Adjustable Speed Drives Washdown/Outdoor Service/ Severe Duty



## Advantages:

STÖBER has developed a severe duty protection package for ComTrac drives which significantly improves the drives' ability to withstand the effects of outdoor use, exposure to excessively humid or acidic environments, or spray washed with water or caustic fluids.

The ComTrac severe duty package includes corrosion protection for all functional components and housings including:

- Drive cone
- Motor clamping ring
- Motor slide and rack
- Bearing housing
- Main housing cover

To prevent corrosion, these components are protected by a special heat treatment process similar to chrome plating.

## Features:

**Drive cone** – Corrosion protected drive cone extends cone and ring life.

**Speed adjustment** – The protected motor slide, stainless steel control shaft with pinion, and greased rack and slideway assure the proper speed adjustment.

**NEMA C-face input** – ComTrac's patented corrosion resistant collet clamp ring assures ease of motor replacement.

**External surface** – All external surfaces are protected with a special acid-resistant epoxy paint to prevent corrosion and lubricant contamination.

**Internal surface** – All internal surfaces and bearing housing are protected with a special anticorrosion paint.

**Double seals** – Double output seals can be provided for maximum protection in very harsh environments.

**Mounting position** – ComTrac drives in a vertical mounting position (output shaft down) must be adapted to allow water to drain.

**Stainless steel nameplate** – Other features of the severe duty unit are: stainless steel nameplate, rivets, and chrome plated bolts.

**Two year warranty** – Like the standard drive, this ComTrac unit is also backed by a two-year warranty.

**Delivery** – ComTrac units are shipped in 3 days or less.



STANDARD  
**3-DAY**  
DELIVERY

MISCELLANEOUS





## "C" Series – Concentric Helical MGS® Adjustable Speed Drives

STOBER can offer a wider variety of sizes, ratios, and mounting positions than ever before by utilizing MGS Reducers and ComTrac Adjustable Speed Drives. These versatile gear drives offer you performance, durability, and economy for a wide range of variable speed applications. High efficiency helical gearing keeps motor size to a minimum while conserving energy.

### Performance Specifications:

- Horsepower ratings – from 1/2 to 10
- Output speeds – available from 1139 to 1.2 RPM
- Speed range – 5:1 to 7:1
- Output torques – up to 59,782 in.lbs.
- NEMA frames – from 56C to 215TC

STANDARD  
**3-DAY**  
DELIVERY



# "F" Series – Offset Helical MGS® Adjustable Speed Drives



STOBER's versatility continues with MGS Reducers and ComTrac Adjustable Speed Drives when using the Offset Helical Series. Compact size and flexibility make these gear drives a popular choice for applications that require high performance, efficiency, and durability.

#### Performance Specifications:

- Horsepower ratings – from 1/2 to 7 1/2
- Output speeds – available from 528 to .6 RPM
- Speed range – 5:1 to 7:1
- Output torques – up to 9,744 in.lbs.
- NEMA frames – from 56C to 215TC







## "K" Series – Right Angle Helical/Bevel MGS® Adjustable Speed Drives

With the many mounting options available, ComTrac Adjustable Speed Drives and MGS Helical/Bevel Speed Reducers offer consistent, higher input-to-output efficiencies and a configurations for almost any application situation. This added efficiency reduces your costs today through smaller gear drive and motor sizing. Tomorrow, you'll benefit through optimum energy savings.

### Performance Specifications:

- Horsepower ratings – from 1/2 to 10
- Output speeds – available from 569 to .9 RPM
- Speed range – 5:1 to 7:1
- Output torques – up to 99,227 in.lbs.
- NEMA frames – from 56C to 215TC

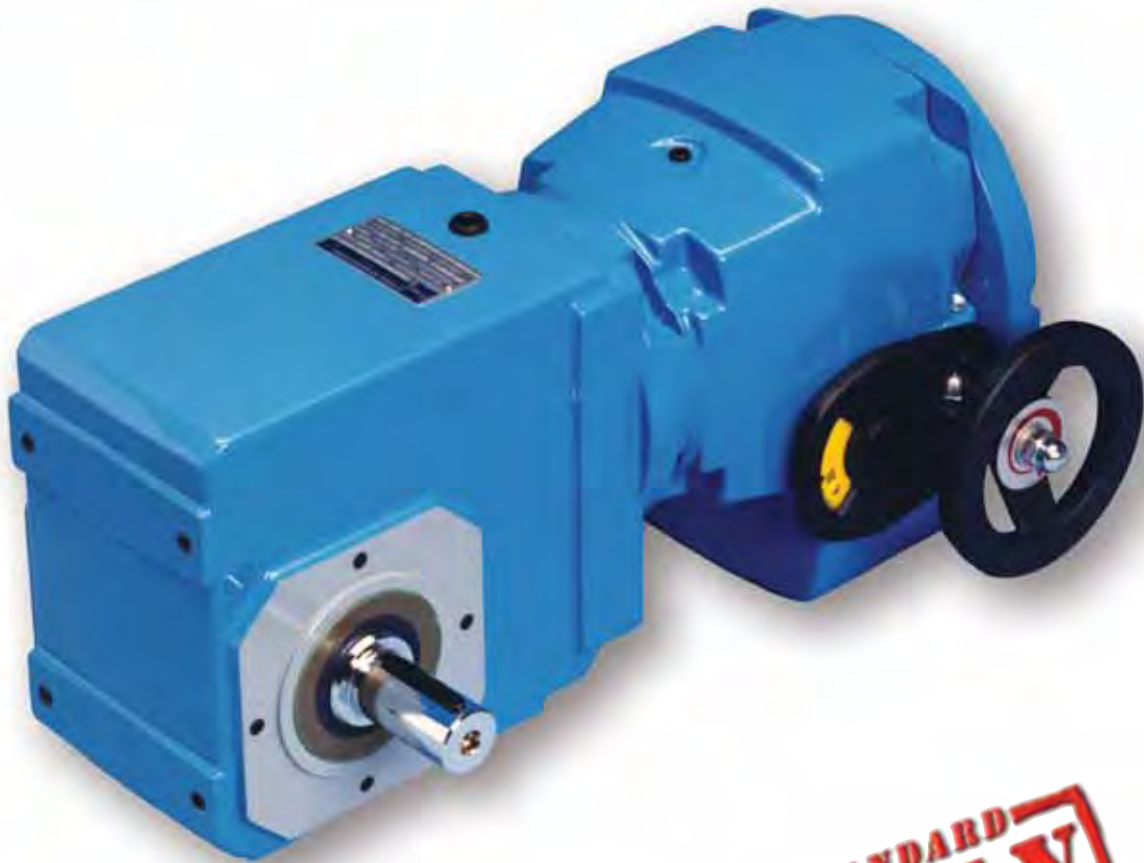

# MGS Reducer AW Input Shaft Dimensional Data

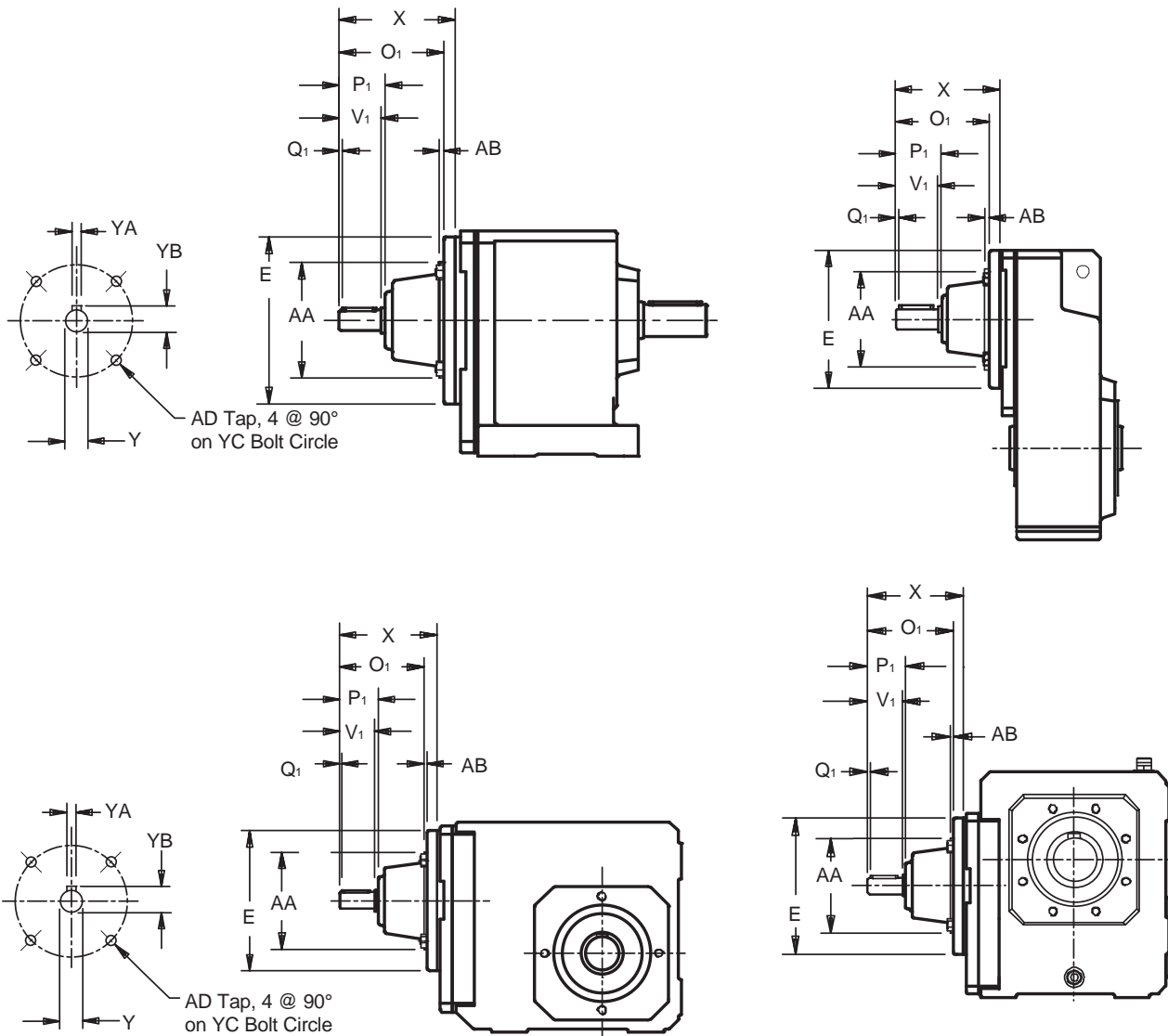

### Part No. Explanation for Input Shaft

**AW160 / 012**

010 ( $10/16 = 5/8$ ), **012** ( $12/16 = 3/4$ ),  
014 ( $14/16 = 7/8$ ), 102 ( $12/16 = 1 1/8$ ),  
110 ( $110/16 = 1 5/8$ ), 202 ( $22/16 = 2 1/8$ )

Input Size: AW140, **AW160**, AW200,  
AW250, AW300, AW350

### Part No. Example

Round Flange with Input Shaft

**S302VF0620 AW160/012**

**Table No. 1** "AW" Input (Inches)

Part No. Input Shaft	E	O <sub>1</sub>	P <sub>1</sub>	Q <sub>1</sub>	V <sub>1</sub>	X	Y	AA	AB	AD	YA - Key	YB	YC	Wt. lbs.	Overhung Load lbs.
<b>AW140/010</b>	5.51	3.58	1.38	.12	1.25	4.02	.6250	3.740	.16	M8	$3/16 \times 3/16 \times 31/32$	.71	4.53	8	98
<b>AW160/012</b>	6.30	4.21	1.69	.12	1.50	4.69	.7500	4.331	.18	M8	$3/16 \times 3/16 \times 17/32$	.83	5.12	12	196
<b>AW200/014</b>	7.87	5.00	1.97	.16	1.75	5.51	.8750	5.118	.16	M10	$3/16 \times 3/16 \times 17/16$	.96	6.50	18	333
<b>AW250/102</b>	9.84	7.20	2.48	.20	2.25	7.80	1.1250	7.087	.16	M12	$1/4 \times 1/4 \times 1 15/16$	1.24	8.46	31	680
<b>AW300/110</b>	11.81	8.39	3.54	.24	3.25	9.02	1.6250	9.055	.20	M12	$3/8 \times 3/8 \times 2 7/8$	1.79	10.43	51	1,072
<b>AW350/202</b>	13.78	10.83	4.88	.28	4.50	11.61	2.1250	9.842	.24	M16	$1/2 \times 1/2 \times 3 15/16$	2.35	11.81	100	1,569



# MGS Reducer Installation Any Unit with Hollow Output

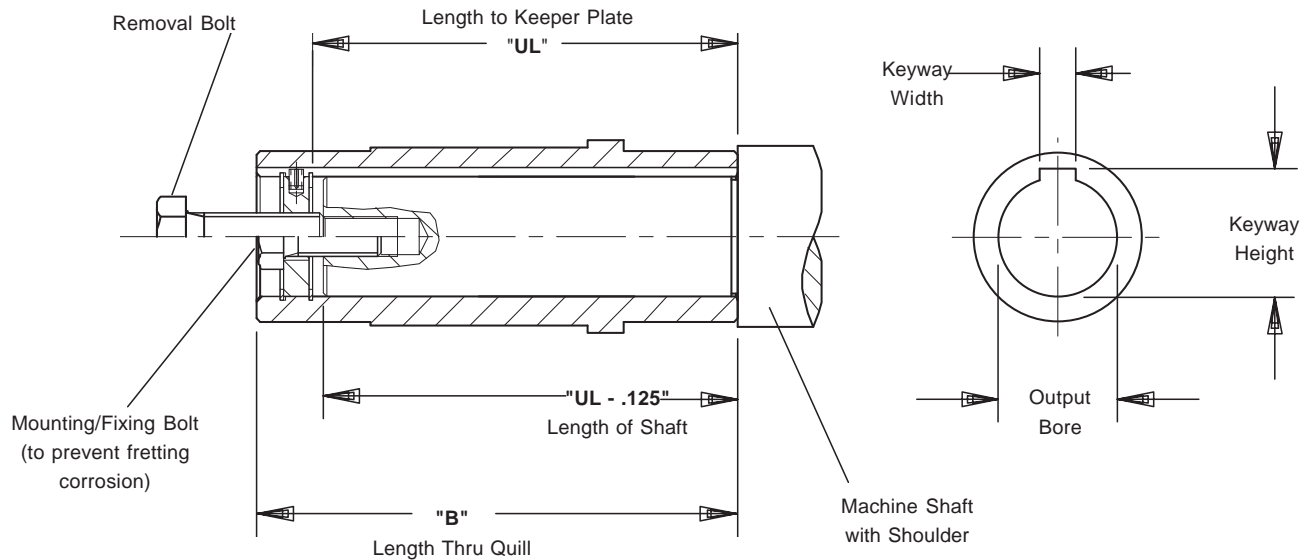

## Mounting Hollow Output Reducers

A STOBER hollow output reducer can be mounted from either side. The tolerance for the hollow bore is shown in the table below and the shaft should be toleranced to fit this bore accordingly.

A keeper plate inside the quill is provided with each unit to prevent axial movement. This keeper plate is held in place with snap rings and can be easily removed for location on either end. A spring pin in the keeper plate mounts into the keyway of the quill and prevents rotation. The keeper plate center hole is tapped to fit the removal bolt.

Before installation, brush the inside of the quill with rust inhibiting grease. When mounting the unit onto the shaft, avoid hammering as this may damage the bearings. Do not mount the reducer dry as removal may be impossible.

The drawing above shows a mounting or fixing bolt and a removal bolt. The mounting/fixing bolt should be smaller in size than the removal bolt. See Table No. 1.

To use the keeper plate with a mounting/fixing bolt, drill and tap the end of the shaft that will be mounted into the reducer. Insert the mounting/fixing bolt through the keeper plate and thread into the shaft end. The machine shaft length should not be longer than the "UL" dimension. A shaft length of "UL minus .125" will allow the shaft shoulder to pull against the face of the quill of the reducer.

## Removal of Hollow Output Reducers

To dismantle the unit from the shaft, remove the mounting bolt. Thread the removal bolt into the keeper plate to press against the shaft and loosen the shaft from the unit. Removal of the reducer will be easier if the quill is greased before installation.

**Table No. 1 "UL" Dimension and Removal Bolt Size**

Unit	Bore	UL	Bolt	Unit	Bore	UL	Bolt	Unit	Bore	UL	Bolt
F1	.750	2.67	3/8-16 NC	K1	1.000	3.86	1/2-13 NC	S1	1.000	3.86	1/2-13 NC
F2	1.000	3.62	1/2-13 NC	K2	1.187	4.78	1/2-13 NC	S2	1.375	4.69	5/8-11 NC
F3	1.250	4.06	1/2-13 NC	K3	1.375	4.92	5/8-11 NC	S3	1.500	5.39	3/4-10 NC
F4	1.500	4.49	3/4-10 NC	K4	1.500	6.18	3/4-10 NC	S4	1.750	6.24	3/4-10 NC
F6	2.000	5.63	3/4-10 NC	K5	2.000	6.46	3/4-10 NC				
				K6	2.000	7.05	3/4-10 NC				
				K7	2.375	8.43	1-8 NC				
				K8	2.750	10.35	1-8 NC				
				K9	3.250	11.89	1-8 NC				
				K10	4.000	14.25	1 1/4-7 NC				

**Table No. 2 Hollow Shaft — "U" Dimension**

Bore Range	Tolerance	Bore Range	Tolerance
.39 – .71	+0.0007 / -.0000	1.97 – 3.15	+0.0012 / -.0000
.71 – 1.18	+0.0008 / -.0000	3.15 Up	+0.0014 / -.0000
1.18 – 1.97	+0.0010 / -.0000		



# MGS Reducers Any Unit Style with Backstops



HP ratings shown are based on 2.0 Service Factor. Maximum HP should not be exceeded.

**DO NOT USE BACKSTOPS ON MAN LIFTS!**

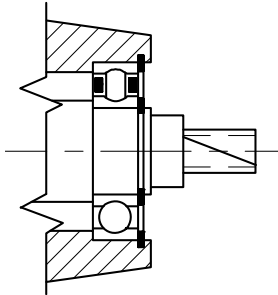

Backstop for all units using: AWB140/010, AWB160/012, MRB140/050, MRB160/050 and MRB160/140

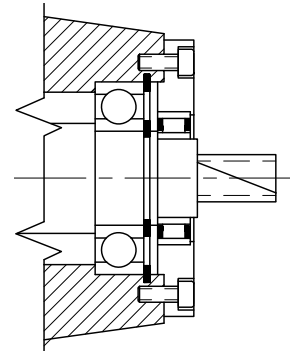

Backstop for AWB200/ 014 through AWB350/202 and MRB200/050 through MRB350/360.

These backstops cannot be assembled in:  
C613, C713, C813, and C913  
K714, K814, K914, and K1014

**Table No. 1 AW with Backstop**

Input Part No.	Shaft Size	Max. HP * @ 1750 RPM
<b>AWB140/010</b>	.625	2.1
<b>AWB160/012</b>	.750	10.4
<b>AWB200/014</b>	.875	18.2
<b>AWB250/102</b>	1.125	29.1
<b>AWB300/110</b>	1.625	40.5
<b>AWB350/202</b>	2.125	54.0

**Table No. 2 MR with Backstop**

Adapter Part No.	NEMA Frame	Max. HP * @ 1750 RPM
<b>MRB140/050</b>	56C	2.1
<b>MRB160/050</b>	56C	10.4
<b>MRB160/140</b>	143/145TC	10.4
<b>MRB200/050</b>	56C	18.2
<b>MRB200/140</b>	143/145TC	18.2
<b>MRB200/180</b>	182/184TC	18.2
<b>MRB250/180</b>	182/184TC	29.1
<b>MRB250/210</b>	213/215TC	29.1
<b>MRB300/180</b>	182/184TC	40.5
<b>MRB300/210</b>	213/215TC	40.5
<b>MRB300/250</b>	254/256TC	40.5
<b>MRB300/280</b>	284/286TC	40.5
<b>MRB350/320</b>	324/326TC	54.0
<b>MRB350/360</b>	364/365TC	54.0

**The direction of rotation of the OUTPUT *must* be specified when ordering a unit with a backstop.**

See the following page for illustration of standard direction of rotation.  
(Examples shown are EL1 mounting – input rotating counterclockwise (CCW).)

**If the backstop is assembled for the standard rotation shown, but rotates in the opposite direction at startup, damage to the backstop is certain.**







# MGS Reducers Standard Direction of Rotation

## "C" Series – Concentric Helical

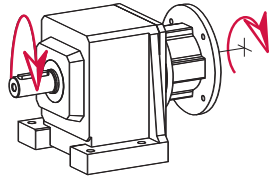

**C002 – C912**

Input and Output Rotate the Same Direction

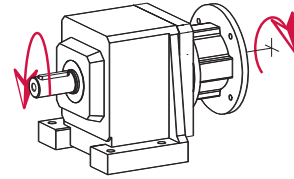

**C103 – C913**

Input and Output Rotate Opposite Direction

## "F" Series – Offset Helical

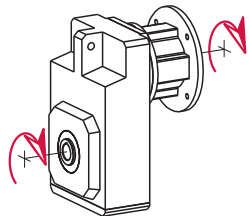

**F102 – F602**

Input and Output Rotate the Same Direction

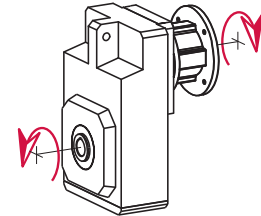

**F203 – F603**

Input and Output Rotate Opposite Direction

## "K" Series – Right Angle Helical/Bevel

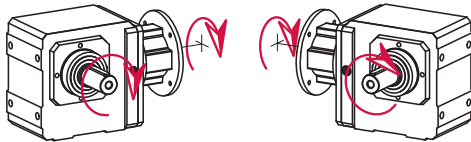

Shaft Side 4

Shaft Side 3

**K102 – K402**

CCW Input and CW Single Output

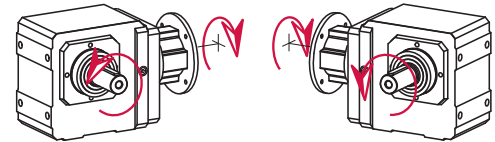

Shaft Side 4

Shaft Side 3

**K203 – K403**

CCW Input and CCW Single Output

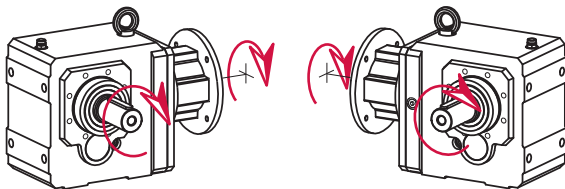

Shaft Side 4

Shaft Side 3

**K513 – K1013**

CCW Input and CW Single Output

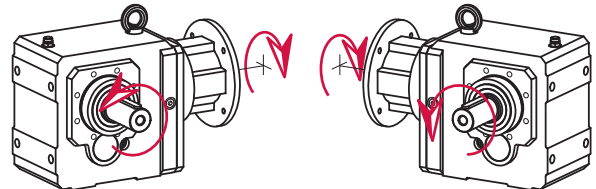

Shaft Side 4

Shaft Side 3

**K514 – K1014**

CCW Input and CCW Single Output

## "S" Series – Right Angle Helical/Worm



Shaft Side 4 – CCW

Shaft Side 3 – CW

**S102 – S402**

CCW Input and Single Output Rotation

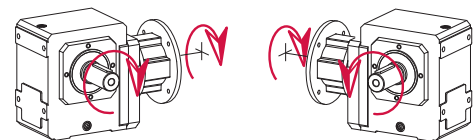

Shaft Side 4 – CW

Shaft Side 3 – CCW

**S203 – S403**

CCW Input and Single Output

### REMINDER:

With a "K" or "S" unit double output, the shaft rotation on Side 3 will be opposite the rotation of Side 4.

# MGS Reducers NEMA C-Face Motor Installation Instructions



## Step 1. Measure the Motor Shaft

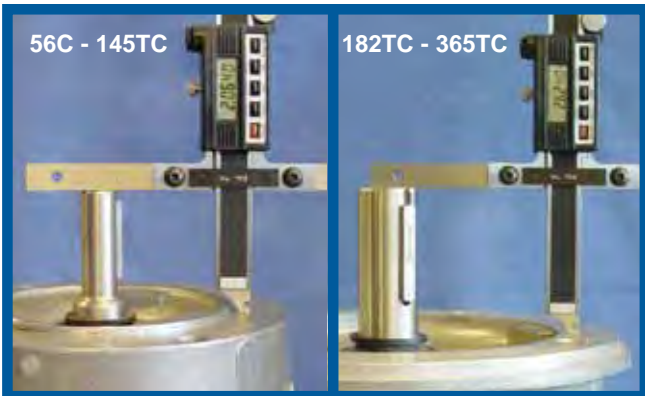

Accurate measurement of the motor shaft is vital to mounting the motor coupling correctly. The measurement must be taken from the face of the motor or pilot surface (see above) to the end of the motor shaft. If this dimension is the same as the NEMA standard "AH" dimension shown in Table No. 1, proceed with the motor mounting in Step 2.

**Table No. 1 NEMA Motor Shaft Dimensions**

Motor Frame	"AH"	Shaft Dia.	Motor Frame	"AH"	Shaft Dia.
<b>56C</b>	2 <sup>1</sup> / <sub>16</sub>	5/8	<b>254/256TC</b>	3 <sup>3</sup> / <sub>4</sub>	1 <sup>5</sup> / <sub>8</sub>
<b>143/145TC</b>	2 <sup>1</sup> / <sub>8</sub>	7/8	<b>284/286TC</b>	4 <sup>3</sup> / <sub>8</sub>	1 <sup>7</sup> / <sub>8</sub>
<b>182/184TC</b>	2 <sup>5</sup> / <sub>8</sub>	1 <sup>1</sup> / <sub>8</sub>	<b>324/326TC</b>	5	2 <sup>1</sup> / <sub>8</sub>
<b>213/215TC</b>	3 <sup>1</sup> / <sub>8</sub>	1 <sup>3</sup> / <sub>8</sub>	<b>364/365TC</b>	5 <sup>5</sup> / <sub>8</sub>	2 <sup>3</sup> / <sub>8</sub>

If the motor shaft length measurement is less than "AH", **subtract** the difference ( $\Delta_1$ ) from the "X" dimension shown in Table No. 2. If the motor shaft length measurement is greater than "AH", **add** the difference ( $\Delta_2$ ) to the "X" dimension shown in Table No. 2.

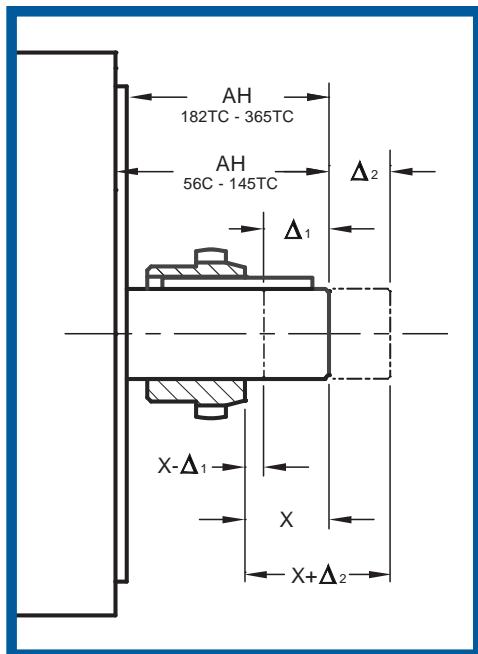

## Step 2. Locate the Motor Coupling on the Motor Shaft



Mount the coupling with the hub projection toward the step or shoulder of the motor. The motor shaft should project through the coupling by the "X" dimension (or the value determined using the previous measurement).

**Table No. 2 Location of Motor Coupling**

Adapter Part No.	"X" mm	"X" inches	Adapter Part No.	"X" mm	"X" inches
<b>MR140/050</b>	28	1.1	<b>MR250/210</b>	46	1.8
<b>MR160/050</b>	22	.9	<b>MR300/180</b>	10	.4
<b>MR160/140</b>	25	1.0	<b>MR300/210</b>	26	1.0
<b>MR200/050</b>	12	.5	<b>MR300/250</b>	42	1.7
<b>MR200/140</b>	12	.5	<b>MR300/280</b>	58	2.3
<b>MR200/180</b>	30	1.2	<b>MR350/320</b>	64	2.5
<b>MR250/180</b>	30	1.2	<b>MR350/360</b>	80	3.1

"X" Tolerance – +1mm / -0mm (+0.040 / -0.000 inches)

## Step 3. Tighten the Setscrew



With the coupling hub located at the correct distance, tighten the setscrew in the coupling.



# MGS Reducers

## NEMA C-Face Motor Installation Instructions

### Step 4. Secure the Motor Shaft Key



For ease of installation, secure the motor shaft key. Staking near the end of the keyway, on the sides of the key, or a temporary adhesive works well.

### Step 5. Mount the Motor



With the coupling secure, insert the motor shaft into the motor adapter. The coupling sleeve is already installed on the mating reducer coupling hub inside the motor adapter. **The sleeve should move freely in an axial direction.** (Axial displacement  $\pm .040$  inches.)

With the motor in place, tighten the motor bolts.

**CAUTION: IF THE MOTOR COUPLING IS NOT INSTALLED CORRECTLY, THE INPUT BEARING MAY FAIL DUE TO PRELOAD. THIS WILL VOID THE WARRANTY OF THE REDUCER AND POSSIBLY FAIL THE MOTOR.**

Some motor manufacturers provide a drain hole in the mounting face of washdown motors. In some mounting positions, water or other material can enter the motor adapter and fail the bearing.

**Be sure this hole is covered during washing or when the unit is in a wet environment.** The illustration below shows the method that STÖBER assembly personnel use to plug the hole.

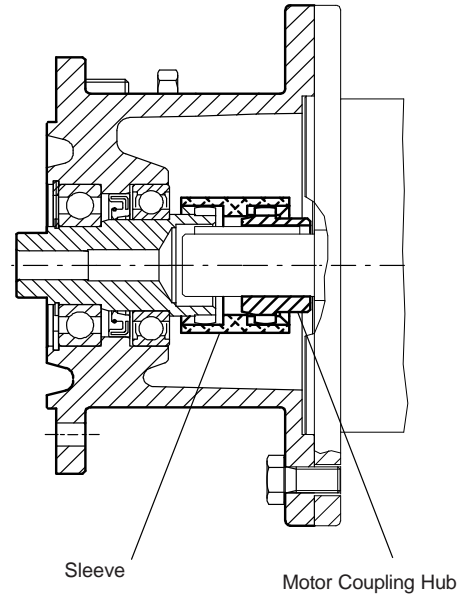
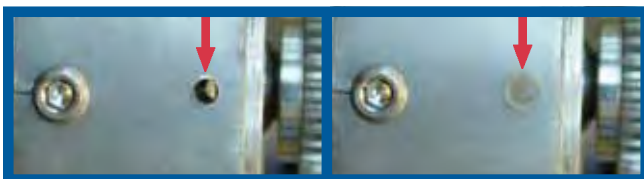

**Table No. 3**  
**Couplings Used with MR Motor Adapters**

Adapter	NEMA Frame	Motor Hub	Sleeve
MR140/050	56C	M-19 x $\frac{5}{8}$	M-19
MR160/050	56C	M-24 x $\frac{5}{8}$	M-24
MR160/140	143/145TC	M-24 x $\frac{7}{8}$	M-24
MR200/050	56C	M-32 x $\frac{5}{8}$	M-32
MR200/140	143/145TC	M-32 x $\frac{7}{8}$	M-32
MR200/180	182/184TC	M-32 x $1\frac{1}{8}$	M-32
MR250/180	182/184TC	M-38 x $1\frac{1}{8}$	M-38
MR250/210	213/215TC	M-38 x $1\frac{3}{8}$	M-38
MR300/180	182/184TC	M-48 x $1\frac{1}{8}$	M-48
MR300/210	213/215TC	M-48 x $1\frac{3}{8}$	M-48
MR300/250	254/256TC	M-48 x $1\frac{5}{8}$	M-48
MR300/280	284/286TC	M-48 x $1\frac{7}{8}$	M-48
MR350/320	324/326TC	M-65 x $2\frac{1}{8}$	M-65
MR350/360	364/365TC	M-65 x $2\frac{3}{8}$	M-65







# "K" Series – MGS Helical/Bevel Reducer "WFB" – Wobble Free Bushing Installation Instructions

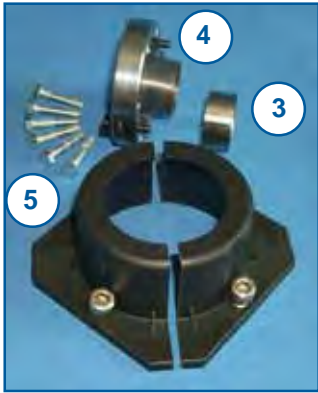

**Support Side  
Bushing Components**

The Support Side is the bushing with the coating on the cone. Do NOT use cleaner on the coated cone.

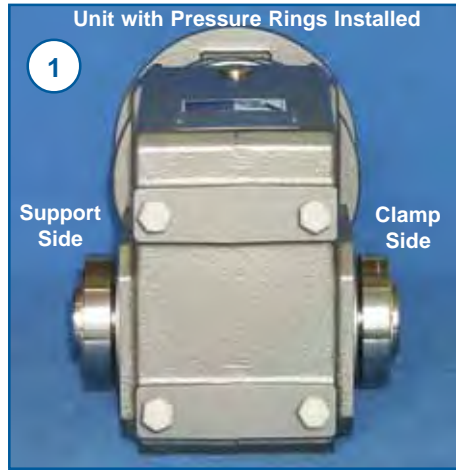

**Unit with Pressure Rings Installed**



**Clamp Side  
Bushing Components**

## Support Side Installation



**Insert Tapered Cone**

K1 units do not have a tapered cone.



Be sure the inside of the quill is free of grease and oil before installing the tapered cones.

## Clamp Side Installation



**Insert Tapered Cone**

K1 units do not have a tapered cone.



**Install Flanged Cone Assembly**

Install the Flanged Cone Assembly (4) with its slot opposite the slot in the tapered cone (3).



**Maintain "U" Dimension**

The "U" distance (between the rings) determined by the spacer bolts (see Table 1) must be maintained throughout assembly of the bushing and mounting onto the shaft. Therefore, **DO NOT** tighten the capscrews or remove the spacer bolts until the unit is mounted on the shaft.



**Install Flanged Cone Assembly**

Install the Flanged Cone Assembly (7) with its slot opposite the slot in the tapered cone (6).



**Hand Tighten Capscrews**



**VERY IMPORTANT  
Do NOT Remove Spacer Bolts**



**Hand Tighten Capscrews**





# "K" Series – MGS Helical/Bevel Reducer "WFB" – Wobble Free Bushing Installation Instructions

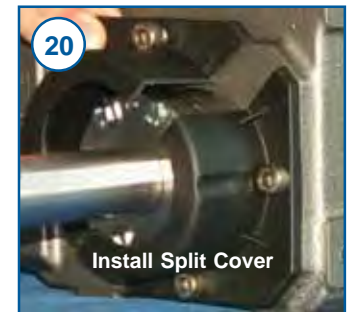
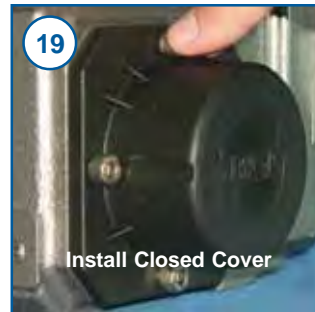
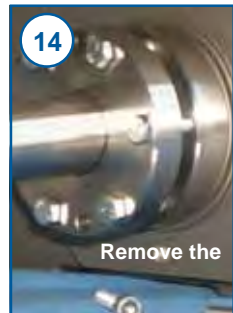
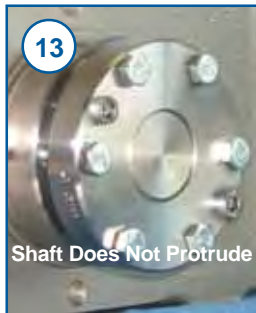
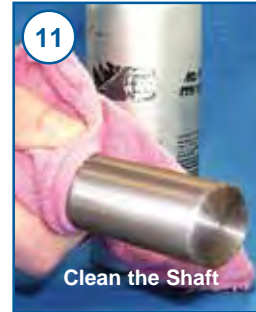

Tighten all capscrews to the torque shown in Table 1. Use a torque wrench. The tightening should be done gradually in a rotating sequence and will require more than one rotation.

After two hours (minimum) running time, check capscrews and retighten, if necessary.



Table No. 1

Base Module	Capscrews		Tightening Torque		U		Spacer Bolts
	Qty.	Size x Length	Nm.	in. lbs.	mm	ins.	
<b>K102</b>	6	M6x25 mm	10	89	5	.20	M6x20mm
<b>K202/K203</b>	6	M6x30 mm	10	89	5	.20	M6x20mm
<b>K302/K303</b>	8	M6x30 mm	10	89	5	.20	M6x20mm
<b>K402/K403</b>	8	M8x30 mm	25	221	6	.24	M8x20mm
<b>K513/K514</b>	8	M8x30 mm	25	221	7	.28	M8x25mm
<b>K613/K614</b>	8	M10x35 mm	49	434	8.5	.33	M10x25mm
<b>K713/K714</b>	8	M10x40mm	49	434	5.5	.22	M10x25mm
<b>K813/K814</b>	8	M12x40mm	85	752	7	.28	M12x45mm

# "KE" Series – MGS Helical/Bevel Reducer Reducer and Motor Installation Instructions



KE Unit with Covers and Bushings

1

The KE Supreme Food Duty unit is shipped with the bushing and covers installed. The bushing bore size is required when ordering and no unit will be shipped without the bushings. Specify Support Side and Clamp Side when ordering. The Support Side is the inboard side or closest to the equipment.

The stainless steel covers are threaded hand tight onto the unit. Remove the covers and protect the threads while handling the unit during installation.



2

Remove the Stainless Steel Covers



3

$\frac{1}{32}$  x 45°  
Chamfer on Shaft End

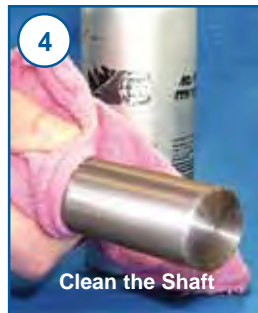

4

Clean the Shaft



5

Slide Support Side stainless steel cover onto shaft as close to equipment as possible.



6

Guide Unit onto Shaft – Shaft Does NOT Protrude

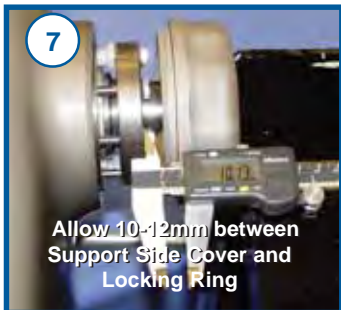

7

Allow 10-12mm between Support Side Cover and Locking Ring



The spacer installed between the Support Side Bushing locking rings will not be removed but will compress as the capscrews are tightened.

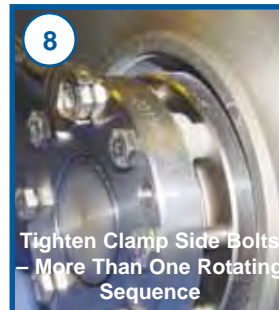

8

Tighten Clamp Side Bolts – More Than One Rotating Sequence



9

Use a Torque Wrench (See Table 1) for Recommended Torque



10

Tighten Support Side Capscrews – More Than One Rotating Sequence

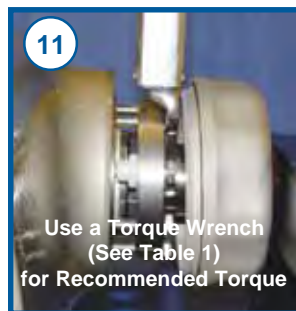

11

Use a Torque Wrench (See Table 1) for Recommended Torque

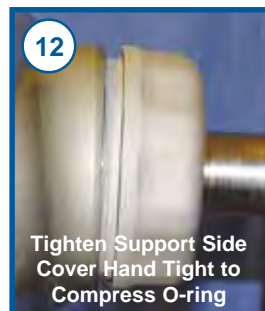

12

Tighten Support Side Cover Hand Tight to Compress O-ring



13

Tighten Clamp Side Cover Hand Tight to Compress O-ring

Table No. 1

Base Module	Capscrews		Tightening Torque	
	Qty.	Size x Length	Nm.	in. lbs.
KE2	6	M6x30 mm	10	89
KE3	8	M6x30 mm	10	89
KE4	8	M8x30 mm	25	221





# "KE" Series – MGS Helical/Bevel Reducer Reducer and Motor Installation Instructions

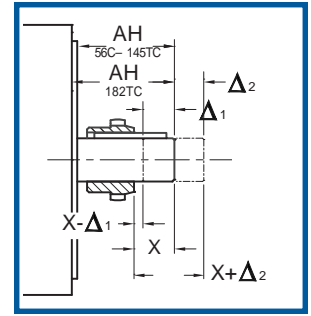
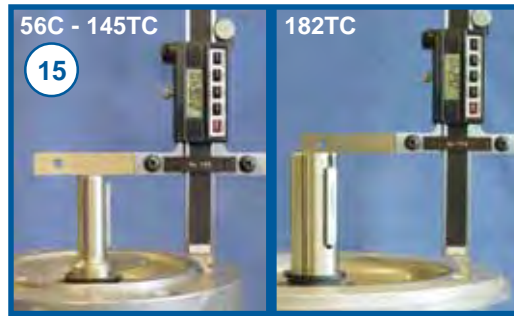

Accurate measurement of the motor shaft is vital to mounting the motor coupling correctly. The measurement must be taken from the face of the motor or pilot surface (see above) to the end of the motor shaft. If this dimension is the same as the NEMA standard "AH" dimension shown in Table No. 2, proceed with the motor mounting.

If the motor shaft length measurement is less than "AH", **subtract** the difference ( $\Delta_1$ ) from the "X" dimension shown in Table No. 3.

If the motor shaft length measurement is greater than "AH", **add** the difference ( $\Delta_2$ ) to the "X" dimension shown in Table No. 3.



Table No. 2

NEMA Motor Shaft Dimensions

Motor Frame	"AH"	Shaft Dia.
56C	2 <sup>1</sup> / <sub>16</sub>	5/ <sub>8</sub>
143/145TC	2 <sup>1</sup> / <sub>8</sub>	7/ <sub>8</sub>
182/184TC	2 <sup>5</sup> / <sub>8</sub>	1 <sup>1</sup> / <sub>8</sub>

Table No. 3

Location of Motor Coupling

Adapter Part No.	"X" mm	"X" inches
MR160/050F	22	.9
MR160/140F	25	1.0
MR200/180F	30	1.2

"X" Tolerance – +1mm / -0mm (+0.040 / -0.000 inches)

Mount the coupling with the hub projection toward the step or shoulder of the motor. The motor shaft should project through the coupling by the "X" dimension (or the value determined using the previous measurement).



# MGS Speed Reducer Lubrication and Mounting Data



## Lubrication and Mounting Position

All STÖBER units are filled with the correct amount of lubrication before shipping. In order to provide the proper lubrication quantity the mounting position must be specified at the time the unit is ordered.

Mounting Position	"C" Series	"F" Series	"K" Series		"S" Series
			K1-K4	K5-K10	
<p><b>EL1</b></p> <p>Side 1 is the bottom side when the unit is set in a normal position. Side 1 is the down side for EL1.</p>					
<p><b>EL2</b></p> <p>Side 2 is the top of the unit. Side 2 is the down side for EL2. (The unit is up-side-down.)</p>					
<p><b>EL3</b></p> <p>Side 3 is the right side when facing the input with the unit in a normal position (EL1). Side 3 is the down side for EL3. Right angle units have the output on Side 3 or 4.</p>					
<p><b>EL4</b></p> <p>Side 4 is the left side when facing the input with the unit in a normal position (EL1). Side 4 is the down side for EL4. Right angle units have the output on Side 3 or 4.</p>					
<p><b>EL5</b></p> <p>Side 5 is the side opposite the motor. Side 5 is the down side for EL5.</p>					
<p><b>EL6</b></p> <p>Side 6 is always the input or motor side. Side 6 is the down side for EL6.</p>					





# MGS Speed Reducer Maintenance and Tolerance Data

The lubricant quantity for the mounting position ordered is stamped on the nameplate of each unit.



## Maintenance

With STOBER reducers very little maintenance is required under normal operating conditions.

Units supplied without breathers are lubricated for life, maintenance free.

Breathers are provided on these standard units:

- C612 through C913
- K513 through K1014
- S102 through S403

STOBER recommends that the lubrication be changed in units supplied with breathers according to the following schedule:

- Normal Operating Conditions – after 5000 Hours
- Wet Operating Conditions – after 2000 Hours.

If food grade or synthetic oil is requested, it will be Mobilgear Special Mist EP220 food grade or Mobilgear SHC630 synthetic.

Characteristic of STOBER Standard Lubricants

	MobilGear XP600	Exxon Special Mist EP220 Food Grade	Mobilgear SHC630
Anti-Foaming Additives	✓	✓	Excellent
Corrosion Protection	✓	✓	Optimum
Extreme Pressure Additives	✓	✓	✓
Friction and Wear Reducing Characteristics	✓	✓	Superior
Oxidation Protection	✓	✓	Enhanced
Wide Temperature Range			✓



## All Series Reducers

**Table No. 1 Solid Shaft — "U" Dimension**

Bore Range	Tolerance	Bore Range	Tolerance
.39 – .71	+0.000 / -.0005	1.97 – 3.15	+0.000 / -.0008
.71 – 1.18	+0.000 / -.0006	3.15 Up	+0.000 / -.0009
1.18 – 1.97	+0.000 / -.0007		

## "F", "K", and "S" Series Reducers

**Table No. 2 Hollow Shaft — "U" Dimension**

Bore Range	Tolerance	Bore Range	Tolerance
.39 – .71	+0.007 / -.0000	1.97 – 3.15	+0.012 / -.0000
.71 – 1.18	+0.008 / -.0000	3.15 Up	+0.014 / -.0000
1.18 – 1.97	+0.010 / -.0000		

## All Series Reducers with Input Shaft

**Table No. 3 Pilot Diameter — "AA" Dimension**

Dia. Range	Tolerance	Dia. Range	Tolerance
3.15 – 4.72	+0.007 / -.0005	9.06 – 12.40	+0.012 / -.0008
4.72 – 7.09	+0.008 / -.0006	12.40 Up	+0.014 / -.0009
7.09 – 9.06	+0.010 / -.0007		

## All Series Flange Mounting Reducers

**Table No. 4 Pilot Diameter — "M" Dimension**

Dia. Range	Tolerance	Dia. Range	Tolerance
3.15 – 4.72	+0.007 / -.0005	9.06 – 12.40	+0.012 / -.0008
4.72 – 7.09	+0.008 / -.0006	12.40 Up	+0.014 / -.0009
7.09 – 9.06	+0.010 / -.0007		

## All Series Reducers with Motor Adapter

**Table No. 5 Pilot Bore Diameter — "YA" Dimension**

Bore Range	Tolerance	Bore Range	Tolerance
1.97 – 3.15	+0.007 / -.0005	7.09 – 9.84	+0.012 / -.0008
3.15 – 4.72	+0.008 / -.0006	9.84 – 12.40	+0.014 / -.0009
4.72 – 7.09	+0.010 / -.0007		

## All Series Reducers

**Table No. 6 Keyway Width — "UA" Dimension**

Bore Range	Tolerance
All Sizes	+0.019 / -.0000

**Table No. 7 Thermal Ratings**

HP	kW	Base Modules			
2.95	2.2	C0	F1	K1	S1
5.36	4.0	C1	F2	K2	S2
7.38	5.5	C2	F3	K3	S3
12.34	9.2	C3	F4	K4	S4
14.75	11.0	C4	F6	K5	—
20.12	15.0	C5	—	K6	—
29.50	22.0	C6	—	K7	—
40.23	30.0	C7	—	K8	—
53.64	40.0	C8	—	K9	—
67.05	50.0	C9	—	K10	—

**Table No. 8 Backlash**

Series	Measured in arc minutes*
C	≤ 20
F	≤ 11
K	≤ 12
S	≤ 20

\* These measurements were taken from actual test of each series.

# MGS Speed Reducer

## Service Factor and Selection Procedure



### Selection Requirements

To select an MGS speed reducer for any application the following must be known:

- Input Speed – Revolutions per Minute (RPM)
- Output Speed – Revolutions per Minute (RPM)
- Input Horsepower (HP) or Output Torque (in. lbs.)
- Application Information to determine the Service Factor

If you have any questions regarding speed reducer selection, contact your STÖBER representative or the STÖBER Technical Support for assistance.

### Horsepower or Torque

MGS speed reducers can be selected by either HP or Output Torque. The following formulas can be used to convert horsepower to torque or torque to horsepower.

$$HP = \frac{\text{Torque (in./lbs.)} \times \text{Output Speed (RPM)}}{63,025}$$

$$\text{Torque (in./lbs.)} = \frac{HP \times 63,025}{\text{Output Speed (RPM)}}$$

### Overhung Loads

Pulling forces or overhung load of pulleys, sheaves, sprockets, etc. on the reducer input and output shaft must not exceed the allowable limits shown in the MGS Selection Data tables. The overhung load shown in the selection tables is measured at the center of the shaft extension. Hollow output units are not intended to support overhung loads. If a overhung load rating is required, use 50% of the published overhung load from the Selection Data. Contact STÖBER Technical Support, if assistance is needed.

The following formula can be used to determine actual overhung load for a given drive.

$$OHL = \frac{126,000 \times HP \times K}{D \times RPM}$$

where

- OHL = Overhung Load (lbs.)
- HP = Horsepower
- D = Pitch Dia. of Sprocket, Gear, Sheave, Pulley, etc.
- RPM = Maximum Speed
- K = 1.00 Chain Drives
- 1.25 Gear Drives
- 1.25 Gearbelt Drives
- 1.50 V-Belt Drives
- 2.50 Flat Belt Drives

No overhung load is encountered when an MGS reducer is flange mounted and/or coupling connected to another unit. However, the shafts of all components must be accurately aligned and secured to prevent pre-loading of the bearings and premature bearing failure.

### Service Factor

Service Factor should be determined for conditions such as non-uniform load, hours of service, and elevated ambient temperature. (For applications powered by an AC motor, a Service Factor of 2.0 is normally sufficient.)

To establish a Service Factor (SF), use the information in Tables 1 to 4.

$$SF = f_b \times f_L \times f_r \times f_v$$

Choose an MGS reducer that will meet or exceed,

$$HP \times SF \quad \text{or} \quad \text{Torque (in./lbs.)} \times SF.$$

**Table No. 1 Load Factor (f<sub>b</sub>)**

Uniform Load	1.0
Non-uniform Load	1.25
Medium Shock	1.4
Severe Shock	1.6

Contact STÖBER Technical Support for selection assistance on applications requiring frequent starts and stops.

**Table No. 2 Hours of Service Factor (f<sub>L</sub>)**

Hours	2	4	6	8	12	16	24
f <sub>L</sub>	.75	.85	.95	1.0	1.10	1.15	1.20

**Table No. 3 Ambient Temperature Factor (f<sub>r</sub>)**

Temperature (°F)	32	50	70	85	100	120
f <sub>r</sub>	1.15	1.15	1.0	1.0	1.15	1.3

For temperatures less than 32° or greater than 120°, contact STÖBER Technical Support.

**Table No. 4 Torque Characteristic Factor (f<sub>v</sub>)**

Use for Frequency Converter Only

Constant Torque over the Entire Speed Variation	1.0
Increasing Output Torque from 87 – 50 Hz	1.7

**NOTE: DO NOT SERVICE FACTOR THE MOTOR.**

### Speed Reducer Selection

- Under the Input RPM heading, find **Nominal Output RPM** nearest the requirement.
- In the **Input HP** column locate the rating that is greater than or equal to the required HP.  
(If selection is based on Torque instead of HP, find an **Output Torque** that is equal to or greater than required.)
- When HP or Torque rating is located, read across that row to select the **Base Module, Input Option** and **Overhung Loads**.
  - Complete Base Module Number by adding Housing Style. See overview pages for housing options available.
  - Select Input Option (Motor Adapter or Input Shaft) and add to completed Part Number.
- Check **Overhung Load**.
- If exact **Output RPM** is required, divide the **Input RPM** by the **Exact Ratio**.

The following additional information should be known when selecting and must be known when ordering an MGS Reducer:

- Mounting position.
- Shaft side extension on right angle units.
- Bushing side when a single side bushing kit is needed.

### Selection Example:

A foot mounted right angle reducer is needed for a uniformly loaded belt conveyor. It will be driven by a 2 HP, 1750 RPM, 145TC NEMA frame motor mounted to the reducer. The output shaft size is undetermined but the output speed required is 128 RPM. The drive will operate 12 hours per day, 5 days per week.

Determine the Service Factor (SF).

Uniform load belt conveyor – Load Factor = **1.00 (f<sub>b</sub>)**

12 hours per day service – Hours of Service = **1.10 (f<sub>L</sub>)**

$$1.00 (f_b) \times 1.10 (f_L) = \mathbf{1.10 SF.}$$

The required HP rating for the reducer is:

$$2 \text{ HP Motor} \times 1.10 \text{ SF} = \mathbf{2.2 \text{ HP}}$$



# MGS Speed Reducer Selection Procedures

**"K" Series – Right Angle Helical/Bevel MGS Reducer – Selection Data**

**Selection Procedure:**

- Under the Input RPM heading, find **Approximate Output RPM** nearest the requirement.
- In the Input HP column, locate the rating that is equal to or greater than the required HP.
- When HP or Torque rating is located, read across that row to select the **Base Module**, **Input Option** and **Overhung Loads**.
- If exact Output RPM is required, divide the Input RPM by the **Exact Ratio**.

1750 RPM Input		Base Module <sup>1)</sup>	Input Options <sup>2)</sup>			Exact Ratio	Overhung Load Output Shaft <sup>3)</sup> lbs.	1150 RPM Input		1160 RPM Input		870 RPM Input						
Input HP	Output Torque in. lbs.		Motor Adapter	NEMA C-Frame Size <sup>4)</sup>	Input Shaft			Input HP	Output Torque in. lbs.	Input HP	Output Torque in. lbs.	Input HP	Output Torque in. lbs.					
<b>135 RPM Output (Approximate)</b>													<b>110 RPM</b>		<b>90 RPM</b>		<b>65 RPM</b>	
25.37	10,805	K813_0130	MR205/140	143/145TC	AW205/014	13.182	4,065	19.37	10,605	15.48	10,605	11.62	10,605					
23.37	10,493	K713_0130	MR205/140	143/145TC	AW205/014	13.043	3,076	19.37	10,493	15.48	10,493	11.62	10,493					
33.30	14,901	K714_0130	MR235/180	182/184TC	AW235/010	13.843	3,076	29.39	15,901	23.48	15,901	17.81	15,901					
33.30	14,304	K713_0130	MR305/190	182/184TC	AW305/110	13.043	3,076	29.39	15,818	23.33	17,147	20.50	16,873					
33.08	16,825	K813_0130	MR235/180	182/184TC	AW235/102	13.182	4,065	30.73	16,825	24.58	16,825	18.44	16,825					
57.74	24,944	K913_0130	MR425/240	182/184TC	AW305/110	13.182	4,065	50.50	27,651	43.52	29,786	35.23	32,151					
<b>125 RPM Output (Approximate)</b>													<b>100 RPM</b>		<b>85 RPM</b>		<b>62 RPM</b>	
1.65	816	K102_0140	MR160/050	56C	AW160/012	14.114	713	1.46	868	1.28	935	1.04	1,029					
1.65	816	K102_0140	MR160/050	56C	AW160/012	14.114	713	1.46	868	1.28	935	1.04	1,029					
2.44	1,181	K202_0140	MR140/050	143/145TC	AW160/012	14.114	713	1.46	868	1.28	935	1.04	1,029					
2.99	1,447	K202_0140	MR160/050	56C	AW160/012	13.851	852	2.54	1,181	1.82	1,181	1.21	1,181					
2.99	1,447	K202_0140	MR160/140	143/145TC	AW160/012	13.851	852	2.84	1,541	2.27	1,680	1.82	1,772					
5.22	2,540	K302_0140	MR160/050	56C	AW160/012	13.935	995	4.60	2,704	3.87	2,913	3.17	3,100					
5.22	2,540	K302_0140	MR205/140	182/184TC	AW205/014	13.830	989	4.60	2,704	3.87	2,913	3.17	3,100					

A. From the Selection Data pages for "K" Series reducers, under the 1750 Input RPM heading, find **125 RPM Output (Approximate)** which is the closest to 128.

B. In the Input HP column, locate the rating that is equal to or greater than 2.2 HP. The first unit available with a 143TC frame is rated at **2.99 HP**.

C. Read across the row to select the **Base Module** and **Input Option**.

1. Complete Base Module Part Number by adding **Output Style** and **Housing Style**.

Example: K202VN0140

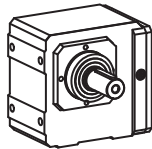

Output Style "V"

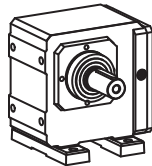

Housing Style "N"

2. Add the **Input Option** to complete the Part Number. Example: K202VN0140 **MR160/140**

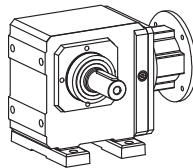

1750 RPM Input		Base Module <sup>1)</sup>	Input Options <sup>2)</sup>			Exact Ratio	Overhung Load Output Shaft <sup>3)</sup> lbs.
Input HP	Output Torque in. lbs.		Motor Adapter	NEMA C-Frame Size <sup>4)</sup>	Input Shaft		
1.65	816	K102_0140	MR160/050	56C	AW160/012	14.114	713
1.65	816	K102_0140	MR160/140	143/145TC	AW160/012	14.114	713
2.44	1,181	K202_0140	MR140/050	56C	AW140/010	13.851	852
2.99	1,447	K202_0140	MR160/050	56C	AW160/012	13.851	852
2.99	1,447	K202_0140	MR160/140	143/145TC	AW160/012	13.851	852
5.22	2,540	K302_0140	MR160/050	56C	AW160/012	13.935	995
5.22	2,540	K302_0140	MR160/140	143/145TC	AW160/012	13.935	995

D. Check **Overhung Load**.

852 lbs. – with the load at the center of the output shaft  
The input load is not a consideration since a motor adapter is used on this unit. If the input shaft option is chosen to use with an auxiliary drive, the input load must be checked.

E. If exact Output RPM is required, divide the Input RPM by the **Exact Ratio**.

$$\frac{1750 \text{ Input RPM}}{13.851 \text{ Exact Ratio}} = 126.34 \text{ Output RPM}$$

1750 RPM Input		Base Module <sup>1)</sup>	Input Options <sup>2)</sup>			Exact Ratio	Overhung Load Output Shaft <sup>3)</sup> lbs.
Input HP	Output Torque in. lbs.		Motor Adapter	NEMA C-Frame Size <sup>4)</sup>	Input Shaft		
1.65	816	K102_0140	MR160/140	143/145TC	AW160/012	14.114	713
2.44	1,181	K202_0140	MR140/050	56C	AW140/010	13.851	852
2.99	1,447	K202_0140	MR160/050	56C	AW160/012	13.851	852
2.99	1,447	K202_0140	MR160/140	143/145TC	AW160/012	13.851	852
5.22	2,540	K302_0140	MR160/050	56C	AW160/012	13.935	995
5.22	2,540	K302_0140	MR160/140	143/145TC	AW160/012	13.935	995

Since Output Style is "V" solid shaft, and is available as a single or double output, the shaft side must be designated. In this case, we will specify the shaft on the left, with the mounting feet on the bottom, and the mounting position as standard horizontal.

The complete part number description for ordering must include the **mounting position**, **shaft side**, and **feet side** designations.

**K202VN0140 MR160/140**  
**EL1**  
**Shaft Side 4**  
**Feet Side 1**

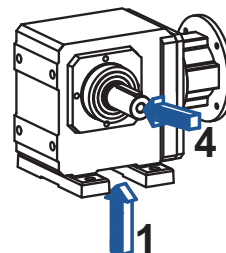



# Terms and Conditions of Sale



1. **GENERAL.** All orders for products supplied by STÖBER DRIVES INC. ("STÖBER") shall be subject to these terms and conditions of sales. All transactions shall be governed by the laws of the Commonwealth of Kentucky. No modifications hereto will be binding unless agreed to in writing by STÖBER.

2. **CUSTOMER.** The term "Customer," as used herein, means the distributor, resale dealer, original equipment manufacturer or first end-user customer that purchases the STÖBER products.

3. **WARRANTY.** STÖBER products shall be free from defects in material and workmanship for a maximum of 5-years (single shift operation or 30 months multiple shift operation) for ServoFit products (ServoFit Modular System, ServoFit Precision Planetary Gearheads, and ServoFit Geared Motors) and MGS Long Life products; 3-years (single shift operation or 18 months multiple shift operation) for other MGS products; 2-years (single shift operation or 12 months multiple shift operation) for ComTrac products, from the date of shipment to the Customer. For ServoFit products, the motor on ServoFit Geared Motors, as well as all normal wear items, including oil seals and bearings, shall be covered for a period of 2-years (single shift operation or 12 months multiple shift operation). In the event that a product proves to be defective, STÖBER's sole obligation shall be, at its option, to repair or replace the product. The repaired or replacement product will be shipped F.O.B. STÖBER's facilities, freight prepaid by STÖBER.

No employee, agent or representative of STÖBER has the authority to waive, alter, vary or add to the terms hereof without the prior written approval of an officer of STÖBER. It is expressly agreed that (a) this section constitutes the final expression of the parties' understanding with respect to the warranty and (b) this section is a complete and exclusive statement of the terms of the warranty.

STÖBER shall have no obligation under the warranty set forth above in the event that:

(a) The Customer fails, within the warranty period to notify STÖBER in writing and provide STÖBER with evidence satisfactory to STÖBER of the alleged defect within five (5) days after it becomes known to the customer;

(b) After inspection of a product, STÖBER determines, in its sole discretion, that it is not defective in material or workmanship;

(c) Repair or replacement of a product is required through normal wear and tear;

(d) Any part in a product or any ingredient contained in a product requires replacement or repair through routine usage or normal wear and tear;

(e) A product is not maintained or used in accordance with STÖBER's applicable operating and/or maintenance manuals, whether by the Customer or any third party;

(f) A product has been subject to misuse, misapplication, negligence, neglect (including, but not limited to, improper maintenance or storage), accident, catastrophe, improper installation, modification, adjustment, repair or lubrication, whether by the Customer or any third party, without the prior written consent of STÖBER. Misuse shall include, but not be limited to, deterioration in a product due to chemical action and wear caused by the presence of abrasive materials;

(g) The system of connected rotating parts into which the product becomes incorporated is not compatible with the product, or it is not free from critical speed or torsional or other type of vibration within the specified operating range, no matter how induced; or

(h) The transmitted load and imposed torsional thrust and overhung loads are not within the published capacity limits for the unit sold.

Items manufactured by other parties but installed in or affixed to STÖBER's products are not warranted by STÖBER and bear only those warranties, express or implied, which are given by the manufacturer of such items, if any.

THE WARRANTY SET FORTH ABOVE IS INTENDED SOLELY FOR THE BENEFIT OF THE Customer AND DOES NOT APPLY TO ANY THIRD PARTY. ALL CLAIMS MUST BE MADE BY THE Customer AND MAY NOT BE MADE BY ANY THIRD PARTY. THIS WARRANTY MAY NOT BE TRANSFERRED OR ASSIGNED, IN WHOLE OR IN PART, BY THE Customer FOR ANY REASON WHATSOEVER. ANY SUCH ATTEMPTED TRANSFER OR ASSIGNMENT SHALL BE NULL AND VOID.

THIS WARRANTY TAKES THE PLACE OF ALL OTHER WARRANTIES, EXPRESS OR IMPLIED, WHICH ARE HEREBY DISCLAIMED AND EXCLUDED BY STÖBER, INCLUDING WITHOUT LIMITATION, ANY WARRANTY OF MERCHANTABILITY OR FITNESS FOR A PARTICULAR PURPOSE OF USE AND ALL OBLIGATIONS OR LIABILITIES ON THE PART OF STÖBER FOR DAMAGES ARISING OUT OF OR IN CONNECTION WITH THE USE, REPAIR OR PERFORMANCE OF THE PRODUCTS.

4. **MODIFICATIONS.** STÖBER reserves the right, without notice to the Customer, to (a) change the specifications of any product, (b) improve a product in any manner that STÖBER deems necessary or appropriate and (c) discontinue the manufacture of any product.

5. **PURCHASE ORDERS.** The Customer will submit purchase orders for the products to STÖBER in writing, whether by mail or telex, which shall set forth, at a minimum: (a) an identification of the products ordered, (b) prices for such products, (c) quantities, (d) requested delivery dates and (e) shipping instructions and shipping addresses.

6. **ACCEPTANCE OF ORDERS.** All purchase orders received from the Customer are subject to acceptance by STÖBER in writing.

7. **MODIFICATION OF ORDERS.** No accepted purchase order shall be modified or canceled except upon the written agreement of STÖBER and the Customer. Mutually agreed cancellations shall be subject to reasonable charges based upon expenses already incurred by STÖBER and commitments made by STÖBER. Mutually agreed change orders shall be subject to all provisions of these Terms and Conditions of Sale.

8. **PRICE INCREASES.** STÖBER may increase its prices for the products by providing the original purchaser of the products with at least thirty (30) days' prior written notice. Increased prices for products shall not apply to purchase orders accepted prior to the effective date of the price increase unless such orders provide for delivery more than thirty (30) days after the date of acceptance of the order.

9. **PRICING AND DELIVERY TERMS.** In accordance with KRS 355.2-319(1)(b), all products are delivered F.O.B. STÖBER's warehouse facility in Maysville, Kentucky, or such other facility as STÖBER may designate. Orders are then shipped per Customer's shipping instructions as set forth in Customer's purchase order. **CATALOG PRICING DOES NOT INCLUDE SHIPPING, HANDLING AND TAXES.** Once delivered to a common carrier of the Customer's choosing [or of STÖBER's choosing if Customer has failed to specify a common carrier on or before five (5) days prior to the requested delivery date] STÖBER shall have no further responsibility for the products and all risk of damage, loss or delay shall pass to the Customer. A handling fee is added to freight costs by STÖBER to cover the cost of having to pay the carrier within seven (7) days when the terms with the Customer are net 30. The Customer has the option of shipping collect with our carrier or the carrier of choice.

10. **PAYMENT TERMS.** Net 30 days. All orders will be shipped either prepaid by the Customer or C.O.D., at STÖBER's option, unless the Customer has established a previously approved credit line. If STÖBER approves a credit line for the Customer, all payments shall be due within thirty (30) days of the date of the invoice. If any invoice is not paid in full within such thirty (30) day period, then finance charges shall be assessed at the rate of one and one-half

percent (1½%) per month (eighteen percent (18%) per year). If such rate is deemed to be usurious at any time, it shall be reduced to the maximum rate permitted by applicable law. STÖBER may stop or withhold shipment of products if the Customer does not fulfill its payment obligations. If STÖBER is insecure about payment for any reason, STÖBER may require full or partial payment in advance and as a condition to the continuation of its delivery of products.

11. **SECURITY INTEREST.** Unless and until the products are paid for in full, STÖBER reserves a security interest in them to secure the unpaid balance of the purchase price. The Customer hereby grants to STÖBER a power of attorney, coupled with an interest, to execute and file on behalf of the Customer all necessary financing statements and other documents required or appropriate to protect the security interest granted herein.

12. **ACCEPTANCE OF PRODUCTS.** The Customer will conduct any incoming inspection tests as soon as possible upon arrival of the products, but in no event later than ten (10) days after the date of receipt. Any products not rejected by written notice to STÖBER within such period shall be deemed accepted by the Customer. STÖBER shall not be liable for any additional costs, expenses or damages incurred by the Customer, directly or indirectly, as a result of any shortage, damage or discrepancy in a shipment.

13. **LIMITATION OF REMEDIES.**

(a) STÖBER SHALL NOT BE LIABLE FOR ANY LOSS OR DAMAGE CAUSED BY DELAY IN FURNISHING THE CUSTOMER WITH PRODUCTS.

(b) IN NO EVENT SHALL STÖBER'S LIABILITY INCLUDE ANY SPECIAL, INDIRECT, INCIDENTAL OR CONSEQUENTIAL LOSSES OR DAMAGES, EVEN IF STÖBER HAS BEEN ADVISED OF THE POSSIBILITY OF SUCH POTENTIAL LOSS OR DAMAGE.

14. **MADE-TO-ORDER PRODUCTS.** STÖBER reserves the right to revoke and amend any price quotations offered to the Customer for made-to-order products, provided that such price quotations have not been accepted by the Customer prior to the date of revocation or amendment.

15. **DIES, TOOLS AND EQUIPMENT.** Charges incurred by the Customer for dies, tools and other equipment shall not confer ownership or the right to possession therein by the Customer. All such dies, tools and equipment shall remain the property of STÖBER, and STÖBER shall have the exclusive right to possession thereof. STÖBER shall maintain such tools and equipment in good working order.

16. **REGULATORY LAWS AND STANDARDS.** STÖBER makes no representation that its products conform to state or local laws, ordinances, regulations, codes or standards except as may be otherwise agreed to in writing by STÖBER.

17. **SIZES AND WEIGHTS.** STÖBER's products are made only in the sizes and to the specifications set forth in its catalogs and other literature. If any alteration is requested, such altered product will be treated as a made-to-order item. STÖBER assumes no responsibility for typographical errors which may appear in its catalogs or literature, and cannot accept alteration charges caused by such errors. Since weights shown in STÖBER's catalogs are approximate, they cannot be used in determining freight allowances set forth in its catalogs and other literature. Freight allowances will be determined at the time of shipment and shall be based on actual shipping weight.

18. **SYSTEM DESIGN.** Responsibility for system design to ensure proper use and application of STÖBER's products within their published specifications and ratings rests solely with the Customer. This includes, but is not limited to, an analysis of loads created by torsional vibrations within the entire system, regardless of how induced.

## STÖBER DRIVES INC.

1781 Downing Drive • Maysville, KY 41056  
Phone: (606) 759-5090 • FAX: (606) 759-5045  
www.stober.com • E-mail: sales@stober.com