

# "KE" - Supreme Food Duty Right Angle Speed Reducers

**NEW**



**3 YEAR WARRANTY**  
**STANDARD  
3-DAY  
DELIVERY**



*"we don't say we're best...our customers do"*

[www.stober.com](http://www.stober.com)

STOBER Drives Inc. is proud to introduce the newly engineered Supreme Food Duty speed reducer. Drawing on the proven high efficiency gearing of the MGS line, then packaging that efficiency into a specialized housing, this new unit is optimized for the harsh environments of the food industry. The features shown below meet the criteria set forth by the American food industry like no other unit available today.

## Even microscopic bugs have Nowhere to Hide on the **STOBER Supreme Food Duty speed reducer!**

Uses the double wobble-free bushing system for easy installation.

Cleanable to a microbiological level.

All units feature

**SILVER**



**BULLET AM™**

anti-microbial coating.

NO niches.

NO product or liquid collections.



NO harborage points.

Mounts in any horizontal output position.

Maintenance free – Lubricated for Life.

Made to food industry compatible materials specifications.

# The **STOBER** difference = **VALUE** for you!

## Size KE2

- Up to 2 HP
- Output Bore Diameters up to 1 1/2 inch
- Ratios up to 46:1
- NEMA C-face for 56C or 143/145TC

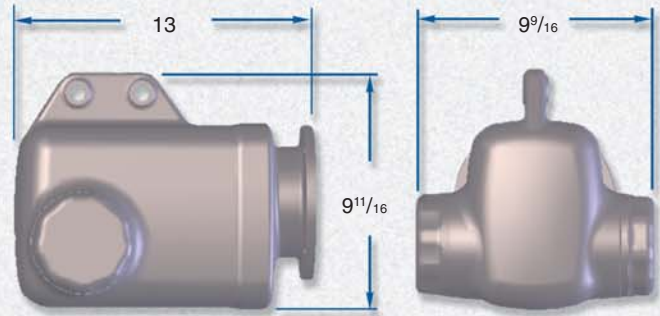

## Size KE3

- Up to 2 HP
- Output Bore Diameters up to 1 1/2 inch
- Ratios up to 56:1
- NEMA C-face for 56C or 143/145TC

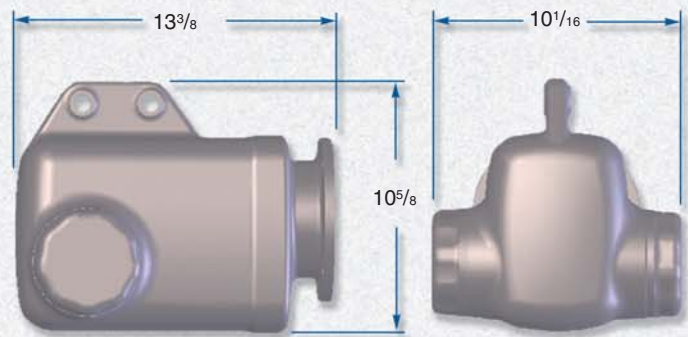

## Size KE4

- Up to 5 HP
- Output Bore Diameters up to 1 1/2 inch
- Ratios up to 69:1
- NEMA C-face for 56C, 143/145C, and 182/184TC

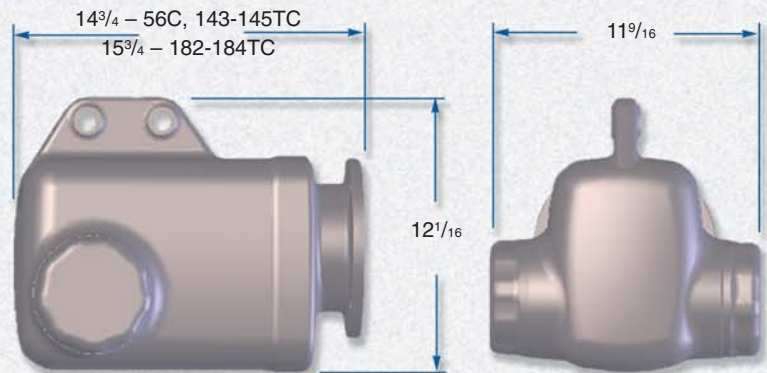

## Part No. Example:

**KE402WB0100MR160/140F-107**

- **KE4** – Right Angle (**K**) Supreme **E** Food Duty Unit Size **4**
- **02** – Double Reduction
- **W** – **W**obble Free Bushing
- **B** – **B**asic Housing (Integral torque arm bracket)
- **0100** – Ratio 0100 (10:1)
- **MR160/140** – Motor Adapter Size for NEMA 143/145TC
- **F** – **F**ood Duty Paint
- **107** – 17/16 bore bushing (WFKE4-**107** for a KE4)  
 Bushing bore size must be specified when ordering.

**Mounts from either side.**

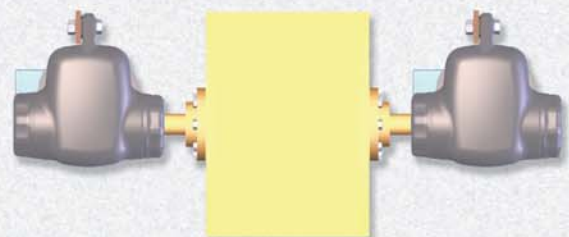

All dimensions are approximate.  
 See MGS speed reducer catalog for available ratios.



**INDUSTRIAL MAGZA**  
DIST. AUTORIZADO

MEX (55) 53 63 23 31 MTY (81) 83 54 10 18  
QRO (442) 1 95 72 60 ventas@industrialmagza.com

**STOBER Drives Inc.**  
Maysville, Kentucky



**ServoFit Modular System Gearheads**

**MGS Food, Beverage, and Poultry Duty Reducers**



**MGS Speed Reducers**



**ComTrac Adjustable Speed Drives**

**STÖBER Antriebstechnik**  
Pforzheim, Germany

**ServoFit Precision Planetary Gearheads**



**STOBER Drives, Inc.**  
1781 Downing Drive, Maysville KY 41056  
Phone: 606 759-5090, FAX: 606 759-5045, Toll Free: 800 711-3588  
Web: [www.stober.com](http://www.stober.com), E-mail: [sales@stober.com](mailto:sales@stober.com)

Silver Bullet AM® is a registered trademark of Burke Industrial Coatings.  
MGS®, STOBER®, ComTrac®, and ServoFit® are registered trademarks of STOBER Drives, Inc.  
Form No. 3025, Copyright June, 2006, Printed in U.S.A.

