

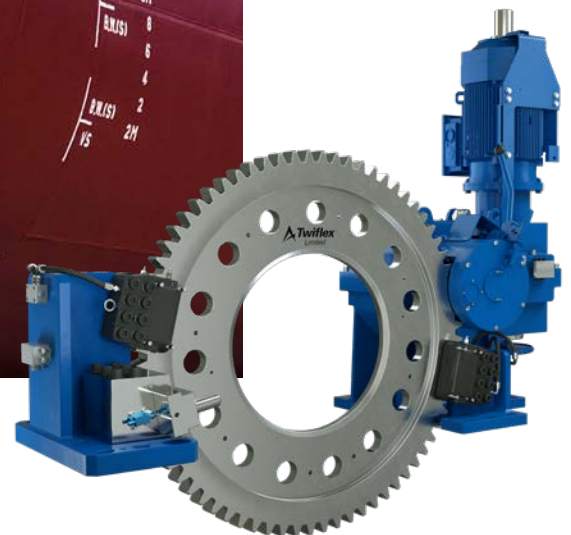

Ameridrives
Bibby Turboflex
Stromag
Svendborg Brakes
Twiflex
Wichita Clutch

Turning, Locking, & Braking Systems for Marine Propulsion



Couplings, Clutches & Brakes

Ameridrives • Bibby Turboflex • Formsprag Clutch • Guardian Couplings
Huco • Industrial Clutch • Lamiflex Couplings • Marland Clutch • Stieber
Stromag • Svendborg Brakes • TB Wood's • Twiflex • Wichita Clutch

ALTRA MOTION PROVIDES POWER TRANSMISSION SOLUTIONS FOR THE MARINE MARKET

As a leading multinational designer and producer of a wide range of electromechanical power transmission equipment, Altra offers products for marine applications where reliability and accuracy are necessary to avoid costly downtime, assure safe operation and consistent performance.

With a full complement of products for the marine market such as clutches, brakes, couplings, gearing, geared motors, and linear actuators, the Altra brands have supported many prominent marine customers for years by providing decades of marine market expertise in a variety of marine applications such as deck machinery (various winches and crane/hoist systems), propulsion systems and auxiliary drives (such as dredge pumps, jet pumps, cutter heads and generator drives).



Altra brands are able to supply products to meet requirements of marine societies including: Lloyds Register of Shipping (LRS), Germanischer Lloyd, Chinese Classification Society, American Bureau of Shipping (ABS), Det Norske Veritas (DNV) Bureau Veritas, RINA (Italian), Russian Register, and Nippon Kaiji Kentei Kyoukai (NK).

www.AltraMotion.com www.Altra-Marine.com

THESE ALTRA BRANDS HAVE SIGNIFICANT EXPERIENCE IN MARINE APPLICATIONS:



WHY MARINE CUSTOMERS CHOOSE ALTRA

A SUPERIOR SOLUTION – LOCAL SUPPORT AROUND THE WORLD

The Altra Marine Technology family provides local sales and service support with global R&D capabilities and production facilities in Europe, North America, South America and Asia Pacific.

- Proven high quality
- Local sales support globally
- Global R&D and testing facilities
- 22 leading PT brands
- Marine service capability
- Long employee retention
- Extensive marine application expertise
- Global engineering centers
- Marine certified
- Local stocking
- Strategic global sourcing
- Production in EU, NA, SA & AP
- Significant PT technical experiences

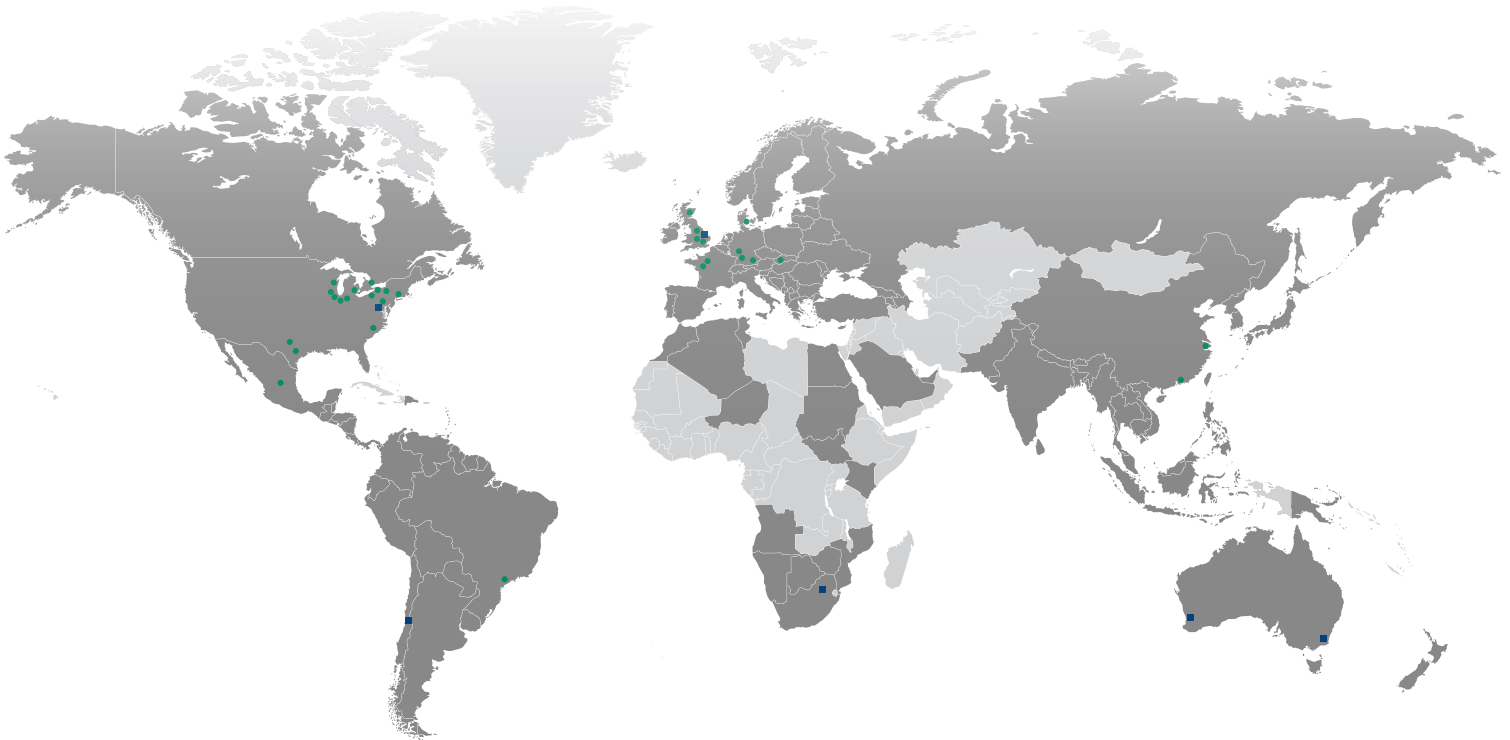

■ Sales Coverage | ● Altra Manufacturing Facilities | ■ Light Manufacturing & Assembly Center

Podded or Azimuth Thruster Brakes

Twiflex, Stromag & Svendborg Brakes

Scissor caliper and modular brake solutions for podded and azimuth drives.

Wide range of pneumatic thruster and direct hydraulic pressure applied options available with braking forces up to 110,160 lb-ft (50,000 kgf).



Shaft Turning, Locking & Braking

Twiflex

Integrated shaft turning and braking system with locking device.

Turning torques in excess of 334,850 lb-ft (454,000 Nm) Braking and locking torques up to 635,780 lb-ft (862,000 Nm) based on the standard range. Optional local controls and split drive gear/disc.

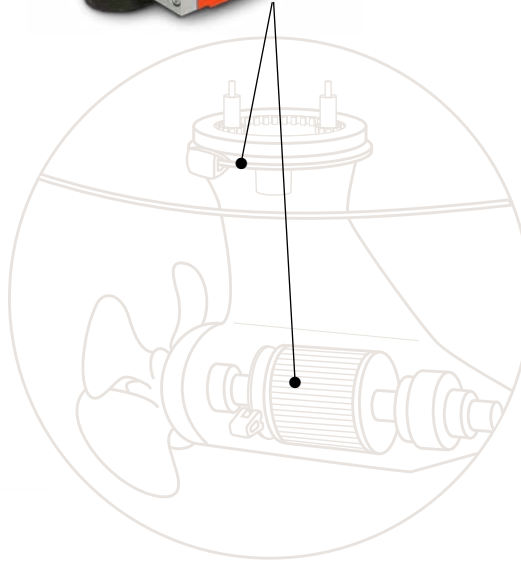

HPB - High Performance Brake

Stromag

Electromagnetic fail-safe brake combined with high performance for small spaces offers the best protection against harsh environmental influences up to IP67.

Comprehensive brake torque range from 60 lb-ft (80 Nm) – 3,688 lb-ft (5,000 Nm).

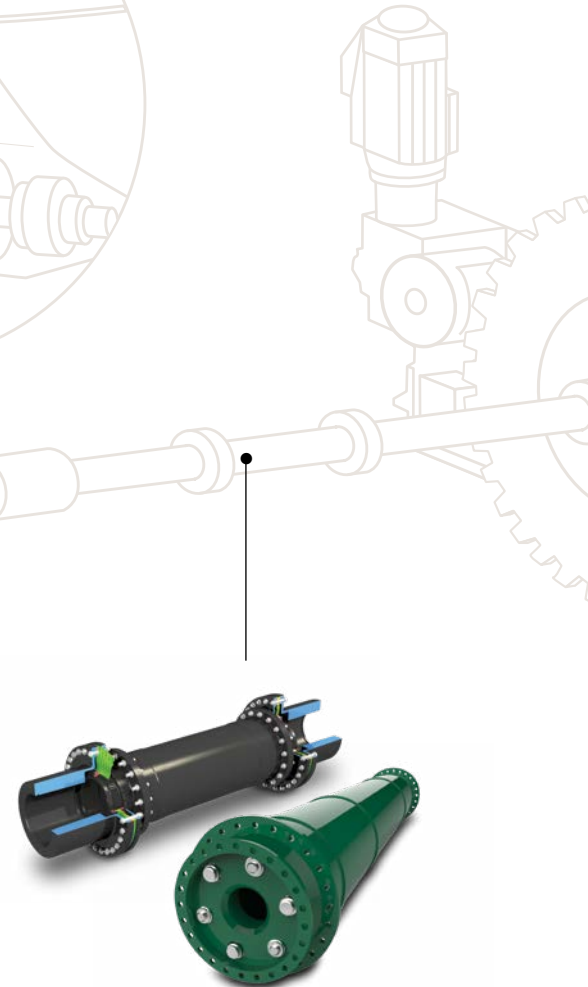

Laylink Coupling

Twiflex

Unique flexible link-coupling to accommodate shaft misalignment. High shock resistance, non-magnetic and good sound attenuation properties.

Shaft Couplings

Ameridrives & Bibby Turboflex

Custom design, light-weight couplings, capable of transmitting high torques at high speeds while accepting significant angular, radial and axial misalignment. High speed couplings for turbine driven water jets.

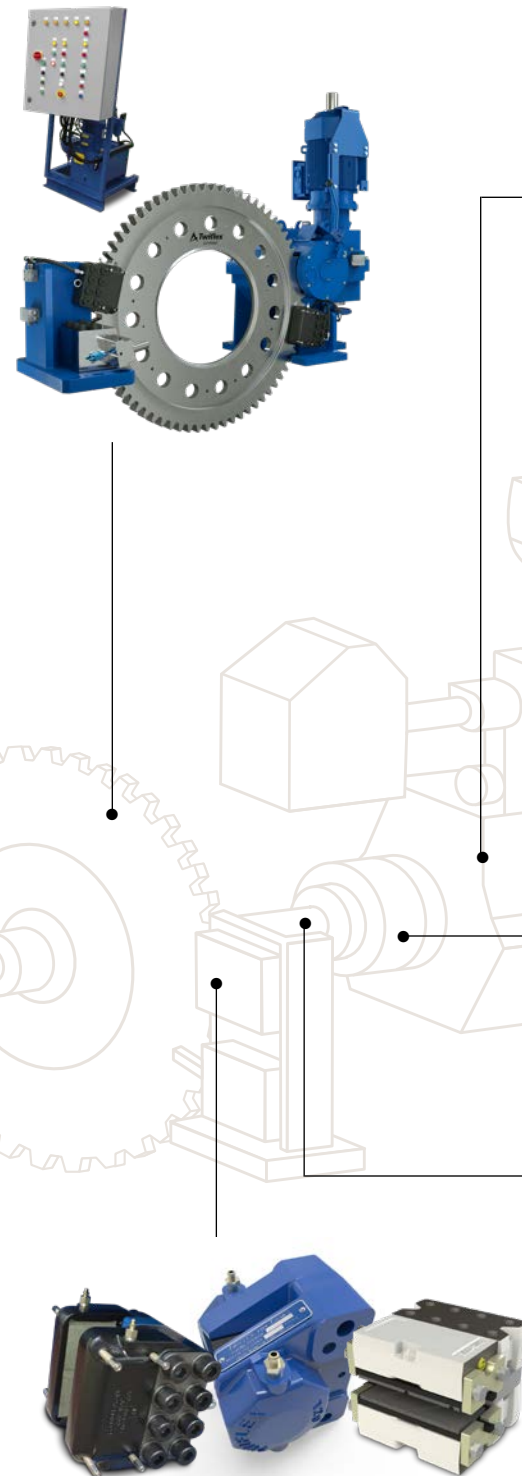

**Direct Applied, Hydraulic or Pneumatic,
Fixed or Floating Shaft Brakes**
Twiflex, Stromag & Svendborg Brakes

Direct (pressure applied) caliper brakes for dynamic shaft stopping and holding. Compact floating solutions for limited space and axial shaft movement.
Braking forces up to 110,160 lb-ft (81,250 Nm)

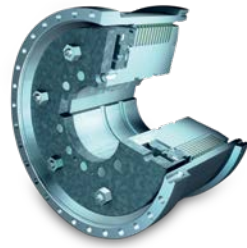

**KMS
Stromag**

Oil cooled and hydraulically operated Multi-Disc Clutches with high thermal load capacity and low mass moment of inertia for marine transmissions.

With a rated torque of over 1,475,000 lb-ft (2,000,000 Nm), a diameter of 3ft (1.2 m), and a weight of nearly 4t, it is the largest and most powerful clutch to date on the entire drive sector.



**TRI-R
Stromag**

Highly-flexible ring couplings, torsional soft with linear characteristic curve and high displacement properties ideal for main and auxiliary marine drives.

Torque range of the TRI-R series is from 848 lb-ft (1,150 Nm) - 46,466 lb-ft (63,000 Nm).



**KMS...THC
Stromag**

A hydraulically operated clutch with high power density, a compact design and a stand-alone solution outside of the transmission. KMS...THC Series has been designed for use in Thruster-Propulsion-Systems.



High Energy Clutches & Brakes
Wichita Clutch

Pneumatic actuated 'high energy' sinter metallic friction clutches for heavy duty drives. High torque and power handling capability to suit a wide range of propulsion and PTO applications. The open style 'pin drive' ring provides for easy dust evacuation and promotes high cooling air flows. Suitable for combination with all major flexible coupling brands.

Torque capacities up to 295,000 lb-ft (400,000 Nm)

TURNING, LOCKING AND BRAKING IN MARINE PROPULSION SYSTEMS



The Twiflex system comprises a Turning gear, Locking device, and shaft Brake (TLB) together with a power unit (e.g. Hydraulic Powerpack) and a control panel for local operation of the system close to the equipment. TLB is available as a continuous turning option as shown or as an indexing system using a simple hydraulic 'push-pull' arrangement with the brakes and brake disc to incrementally inch the propeller shaft for maintenance and accurate alignment. For a more cost effective solution, a simple manual option is also available for this purpose.

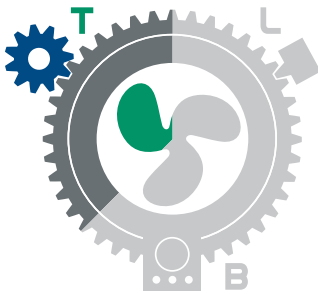

TURNING

TURNING: Low power turning while in port

BEARING CONDITIONING: Eliminates bearing damage due to setting when vessel is moored in port for extended periods

SHAFT ROTATION: Enables shaft rotation during installation and maintenance

POSITIONING: Optimizes propeller blade positioning while at sea and during maintenance and installation

ROTATION: Provides the ability to rotate the shaft when drive is disengaged

INSTALLATION: Quicker and easier installation and setting of drive components

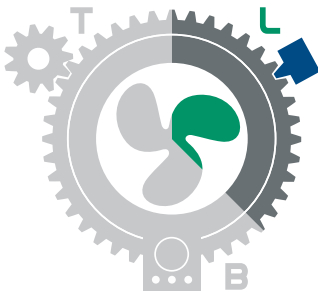

LOCKING

INCREASED SAFETY: Enables locking of the shaft for maintenance

IMPROVED FUEL EFFICIENCY: Used to lock shaft to prevent a wind milling effect while in operation (twin or multiple screw)

SHAFT LINE PROTECTION: Used to protect redundant or damaged shaft line while at sea

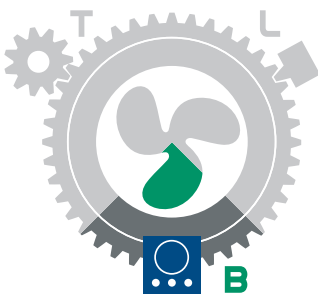

BRAKING

FASTER DIRECTIONAL CHANGES: Used to shorten stopping of rotating shaft or in order to change direction

- Improved maneuverability (twin or multiple screw) allowing better steering for rapid directional change
- Crash astern and crash stop

REDUCE LOAD ON PROPULSION SYSTEMS: used to shorten stopping of rotating shaft when coming into port

- Controlled stopping to protect drive components including gearbox when lubrication system has failed

PREVENT WIND MILLING EFFECT: Shaft holding when unpowered propeller rotates due to the flow stream

BENEFITS OF A COMPLETE INTEGRATED SYSTEM

When purchasing a complete turning gear system integrated with locking and braking from Twiflex, customers can consolidate three separate interfaces into one multi-functional solution: Turning 'T', Locking 'L', and Braking 'B', which enables customers to save dimensional space, decrease installation and maintenance time and reduce costs!

TWIFLEX TURNING, LOCKING AND BRAKING (TLB) SYSTEM

- Twiflex provides a superior solution with a continuous turning design for the same price as a comparable indexing solution
 - Infinite positioning
 - Fixed speed in both directions (variable as an option)
 - Balanced load profile
 - Quicker & safer stopping
- Fully modular solution providing the customer an option to select each function T,L,B, individually or combined TL, TB or LB in addition to the complete TLB system
- Flexible designs to meet customer requirements with full design and build completely in-house
 - Many configurations available based on five standard brake disc sizes with turning torques up to 334,850 lb-ft and turning speeds up to 2.6 rpm depending on configuration.
 - Wide range of well proven locking devices and brakes with torques up to 635,500 lb-ft based on the standard range. Custom disc sizes available.
- Local and Remote operation to suit customer preference
- Manual Turning and Locking available for power failure condition

A Superior Solution From A Single Source

- Complete System Provider: brakes, actuation methods, controls, hydraulics, locking devices, etc.
- Strong Design & Technical Competence
- Full Design & Build In-House
- Custom Modular Solutions
- Renowned Testing Facilities
- Balanced Braking
- Brand Longevity
- Superior Continuous Turning Design
- Extensive Marine Application Expertise
- Marine Service Capabilities

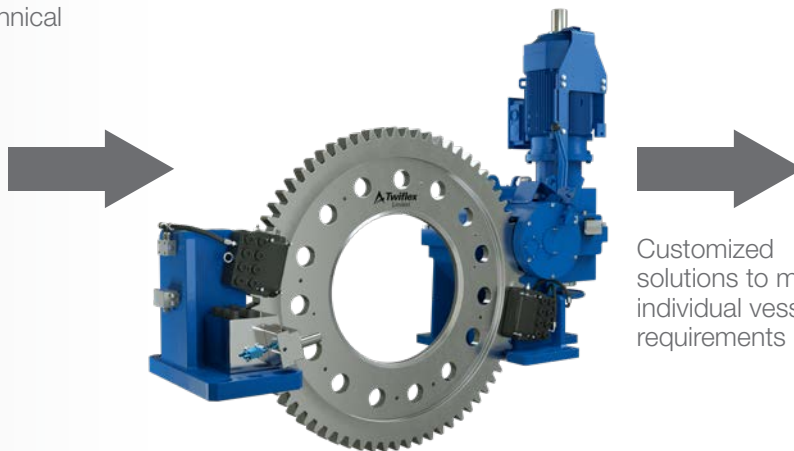

Customized solutions to meet individual vessel requirements

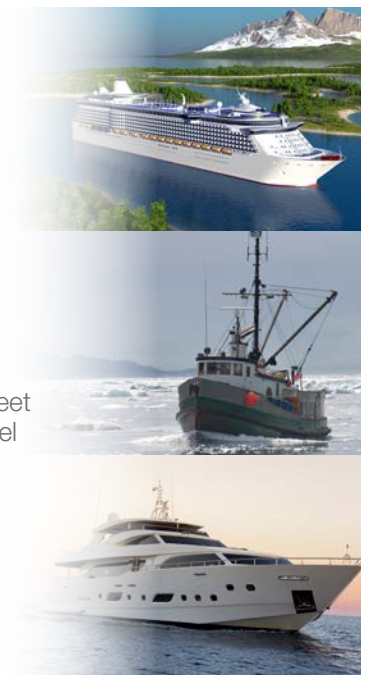

TWIFLEX TLB SYSTEM FOR MARINE PROPULSION

The Twiflex TLB system is fully modular and can be supplied as a complete TLB package or variations as shown above: Turning only 'T', Locking only 'L', Braking only 'B' Turning and Braking 'TB', Locking and Braking 'LB' or Turning and Locking 'TL'.

All systems are fully monitored and are designed to provide an interface with the customers bridge control.

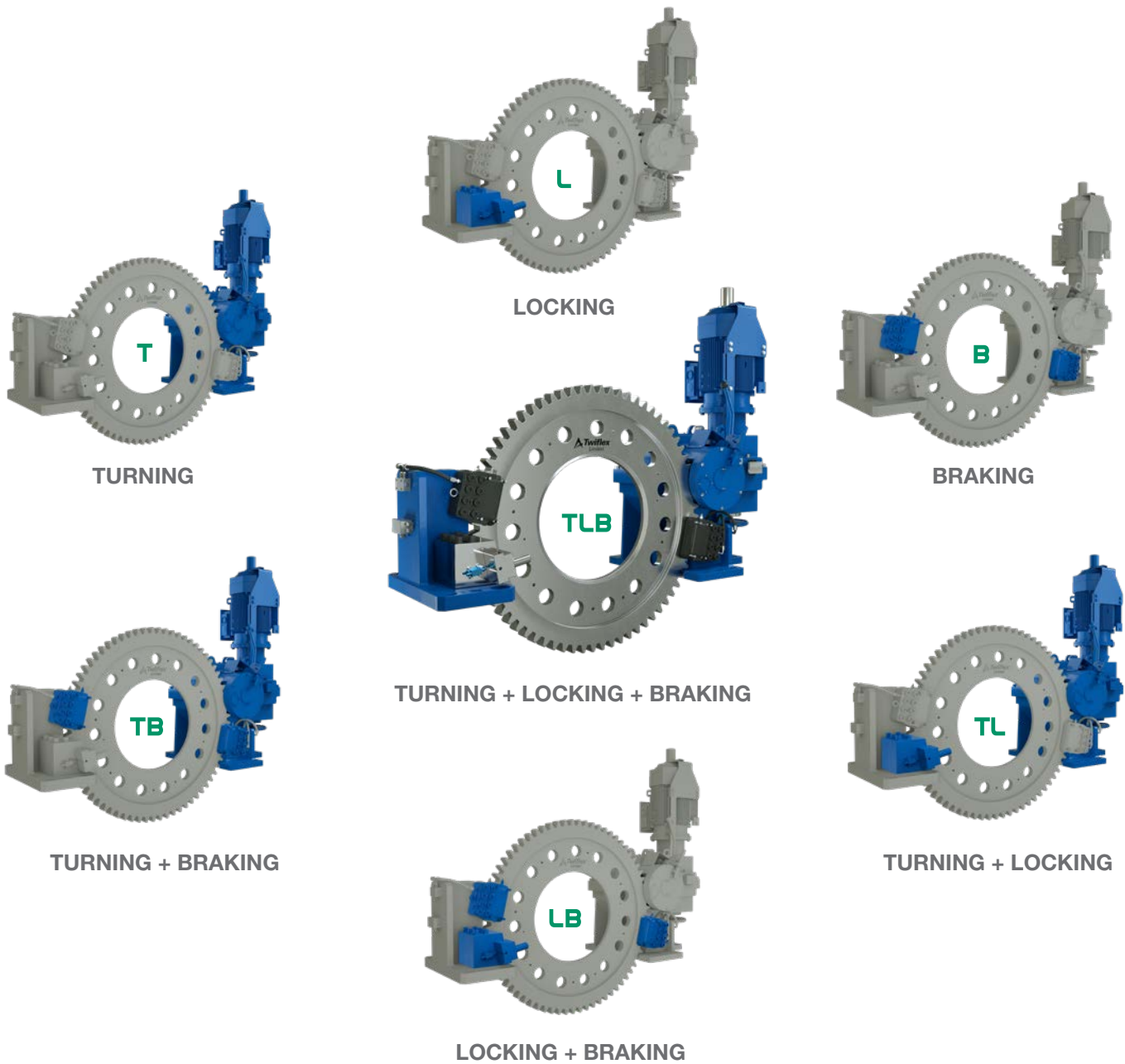

ALTRA HAS MANY YEARS OF EXPERIENCE DESIGNING AND SUPPLYING HYDRAULIC, ELECTRO-PNEUMATIC, AND AIR-OVER-OIL CONTROLS FOR BRAKES AND CLUTCHES USED IN THE MARINE INDUSTRY.

The TLB system includes a fully monitored control system with a remote panel offering local control. While in normal operation, the system is operated and monitored by the ship's bridge control allowing only the brakes to be applied, for example, in an emergency condition or for fast maneuvering to provide rapid directional change for twin screw vessels. In local control, the turning gear and locking device can be operated along with the brakes allowing full TLB control.

For installations where braking and/or locking is required, power units can be supplied in various options (air, hydraulic, air-over-oil) along with an operating panel to provide basic control and monitoring to suit.

Altra also offers a full range of direct pneumatic applied spring release scissor and dual spring brakes along with air-over-oil systems to meet both ship supply options.



TYPICAL TWIFLEX TLB POWER UNIT AND CONTROL

WHY DO CUSTOMERS SELECT **TWIFLEX** TLB SYSTEMS?



Problem: A leading global marine propulsion system OEM required a unique drive shaft turning, locking and braking solution for use on a next-generation ice-breaking vessel. Controlled locally or from the bridge, the equipment fitted to each of the three propeller drives rotates and holds the propulsion shaft during maintenance. It also stops and locks the drive shaft to prevent the propeller from rotating when the vessel is moored in a flow stream.

Solution: The custom Twiflex TLB-180 produces a continuous turning torque of 103,260 lb-ft at 0.6 rpm in both directions with a dynamic braking capacity and static locking torque rated up to 132,760 lb-ft. The system features a 4.9 ft (1.5 m) diameter split disc with a gear tooth profile which easily mounts onto a flange without the need to disassemble the main propulsion shaft.

TWIFLEX TLB SPECIFICATIONS

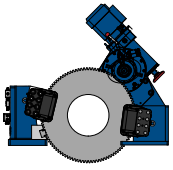
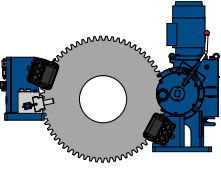
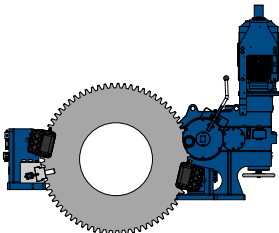
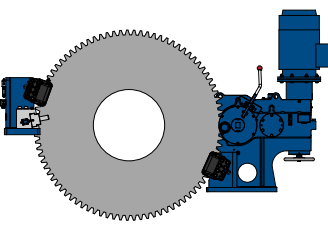
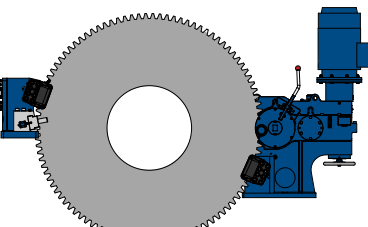
	Disc Dia. (inches)	Turning Torque (lb-ft)		Turning Speed/ (rpm)		Locking Torque (lb-ft)	Braking Torque (lb-ft)	
		Min	Max	Min	Max	Nom	Min	Max
	32	10,550	116,560	0.38	2.64	23,600	11,780	23,570
	48	15,840	174,830	0.25	1.76	53,100	26,580	53,160
	60	19,800	218,540	0.20	1.41	140,140	69,860	139,730
	80	26,400	291,380	0.15	1.06	157,840	78,770	157,530
	92	30,360	335,100	0.13	0.92	635,780	317,770	635,530

- Braking Torques are calculated using direct applied, spring release hydraulic brakes. Direct applied, spring release pneumatic brakes are also available
- Max operating pressure used in the above calculations is 2,176 psi
- Coefficient of Friction (μ) has been taken as 0.4
- Max. Braking Torque assumes 2 off brakes (same model and rating) are used on a single brake disc
- Configurations shown are complete TLB systems with continuous turning (-C). Indexing (-I) or manual systems (-M) are available upon request
- All Turning Gear options include the facility for manual turning in addition to normal operation
- The geared brake disc can be supplied as a solid or as a split design

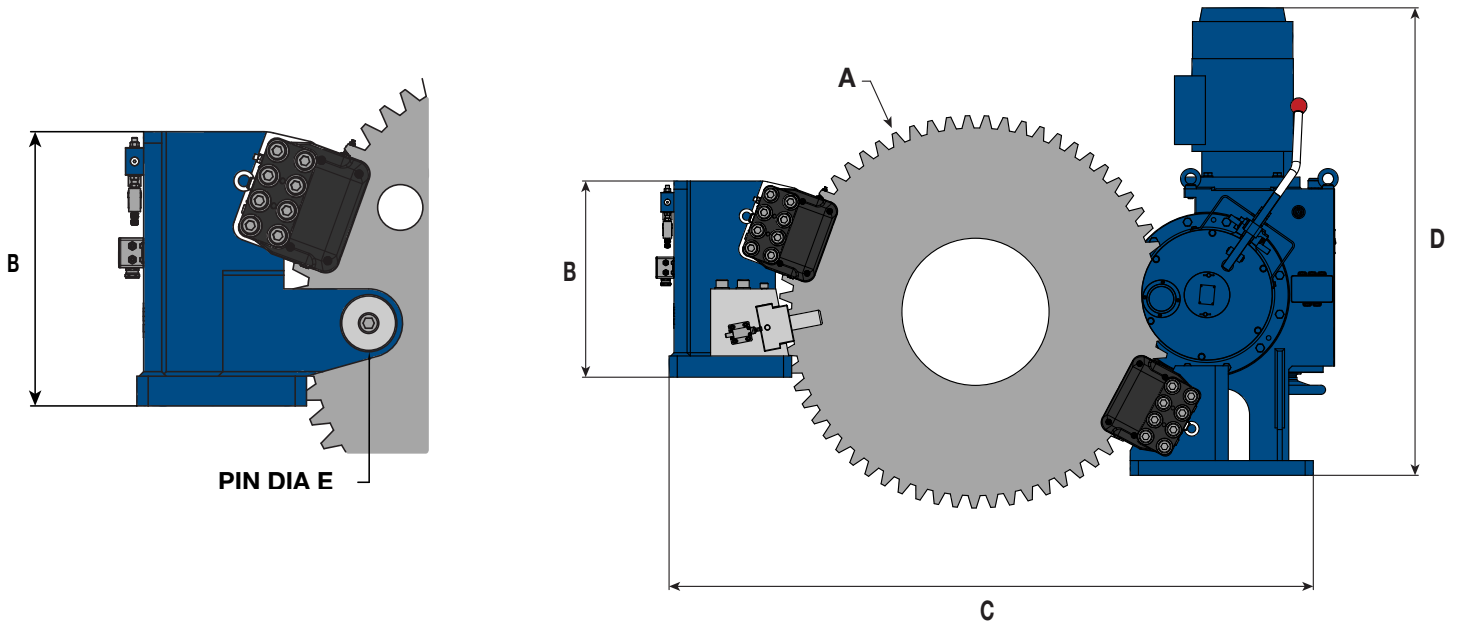

Dimension	TLB80-C	TLB120-C	TLB150-C	TLB200-C	TLB230-C
A	32	48	60	80	92
B	20	24	24	24	24
C	54	80	106	138	148
D	48	58	78	78	78
E	3	4	4	4	6

All dimensions shown in inches

LOCKING DEVICES

- Axial pin or tooth options to suit different disc sizes
- Manually operated as standard, hydraulic and mechanical options upon request
- Engineered custom solutions and status monitoring can be provided



Turning, Locking & Braking Systems
by Twiflex

Twiflex Facilities

Europe

United Kingdom
9 Briar Road, Twickenham
Middlesex TW2 6RB - England
+44 (0) 20 8894 1161
info@twiflex.com
sales@twiflex.com
Industrial Brake Systems

Amphill Road
Bedford, MK42 9RD - UK
+44 (0)1234 350311
Industrial Brake Systems

Germany

Hatschekstraße 36
69126 Heidelberg - Germany
+49 (0) 6221-304719
twiflex-sales@stieber.de
Industrial Brake Systems

North America

USA
2800 Fisher Road
Wichita Falls, TX 76302 - USA
940-723-3483
Toll free: 844-723-3483
twiflex.info@twiflex.com
Industrial Brake Systems

Asia Pacific

Australia
+61 2 9894 0133

China
+86 21 5169-9255

Hong Kong
+852 2615 9313

Singapore
+65 6487 4464

Taiwan
+886 2 2577 8156

Thailand
+66 2322 5527

The Brands of Altra Motion

Couplings

Ameridrives
www.ameridrives.com

Bibby Turboflex
www.bibbyturboflex.com

Guardian Couplings
www.guardiancouplings.com

Huco
www.huco.com

Lamiflex Couplings
www.lamiflexcouplings.com

Stromag
www.stromag.com

TB Wood's
www.tbwoods.com

Linear Systems

Thomson
www.thomsonlinear.com

Warner Linear
www.warnerlinear.com

Geared Cam Limit Switches

Stromag
www.stromag.com

Engineered Bearing Assemblies

Kilian
www.kilianbearings.com

Electric Clutches & Brakes

Matrix
www.matrix-international.com

Stromag
www.stromag.com

Warner Electric
www.warnerelectric.com

Deltran
www.thomsonlinear.com

Belted Drives

TB Wood's
www.tbwoods.com

Heavy Duty Clutches & Brakes

Twiflex
www.twiflex.com

Stromag
www.stromag.com

Svendborg Brakes
www.svendborg-brakes.com

Wichita Clutch
www.wichitaclutch.com

Gearing & Specialty Components

Bauer Gear Motor
www.bauergears.com

Boston Gear
www.bostongear.com

Delevan
www.delevan.com

Delroyd Worm Gear
www.delroyd.com

Nuttall Gear
www.nuttallgear.com

Engine Braking Systems

Jacobs Vehicle Systems
www.jacobsvehiclesystems.com

Precision Motors & Automation

Kollmorgen
www.kollmorgen.com

Miniature Motors

Portescap
www.portescap.com

Overrunning Clutches

Formsprag Clutch
www.formsprag.com

Marland Clutch
www.marland.com

Stieber
www.stieberclutch.com

Neither the accuracy nor completeness of the information contained in this publication is guaranteed by the company and may be subject to change in its sole discretion. The operating and performance characteristics of these products may vary depending on the application, installation, operating conditions and environmental factors. The company's terms and conditions of sale can be viewed at <http://www.altramotion.com/terms-and-conditions/sales-terms-and-conditions>. These terms and conditions apply to any person who may buy, acquire or use a product referred to herein, including any person who buys from a licensed distributor of these branded products.

©2019 by Twiflex LLC. All rights reserved. All trademarks in this publication are the sole and exclusive property of Twiflex LLC or one of its affiliated companies.