



MEX (55) 53 63 23 31 MTY (81) 83 54 10 18
QRO (442) 1 95 72 60 ventas@industrialmagza.com

////// ZERO-MAX[®] Schmidt Couplings



SCHMIDT COUPLINGS OPERATIONAL BENEFITS

INDUSTRIAL MAGZA
 DIST. AUTORIZADO
 MEX (55) 53 63 23 31
 QRO (442) 1 95 72 60
 MTY (81) 83 54 10 18
 ventas@industrialmagza.com



Example 1

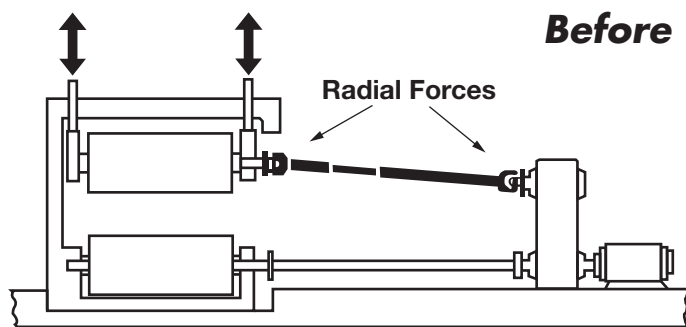

Diagram shows how this can be achieved with double universal joints – but causes radial forces at the joints and requires large lateral space.

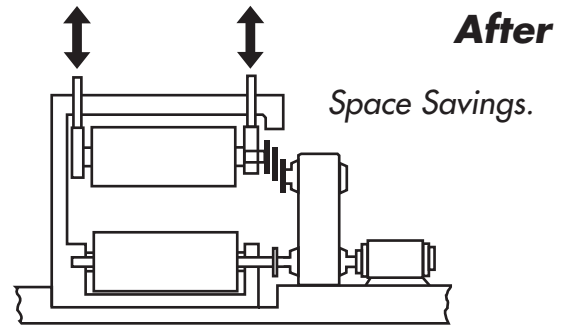
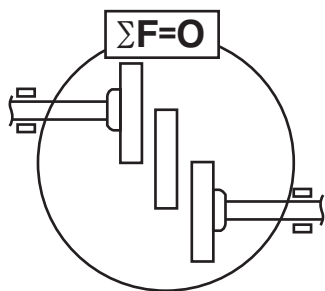

Diagram overcomes both problems – by the use of a Schmidt Offset Coupling.

Example 2



Wide range of parallel shaft displacement without side loads.

Example 3

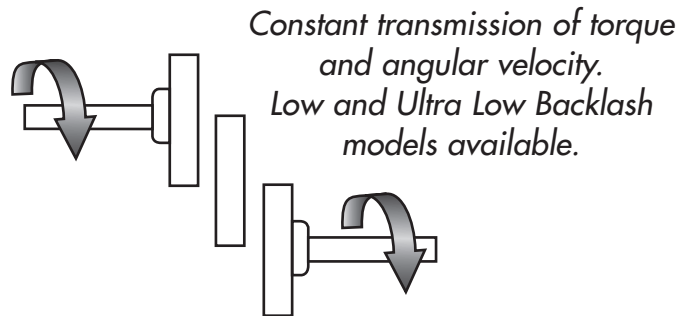

Constant transmission of torque and angular velocity. Low and Ultra Low Backlash models available.

Example 4

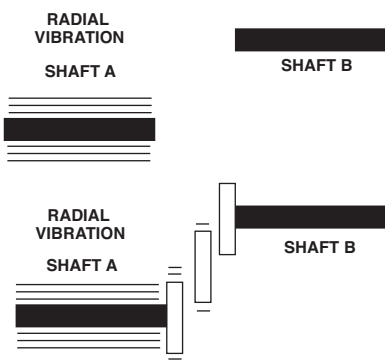

Elimination of radial vibration.

Example 5

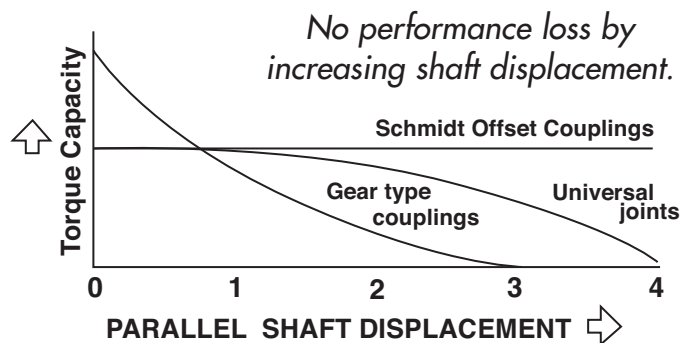

SCHMIDT COUPLINGS **SCHMIDT APPLICATIONS**

INDUSTRIAL MAGZA
DIST. AUTORIZADO

MEX (55) 53 63 23 31
QRO (442) 1 95 72 60
MTY (81) 83 54 10 18
ventas@industrialmagza.com

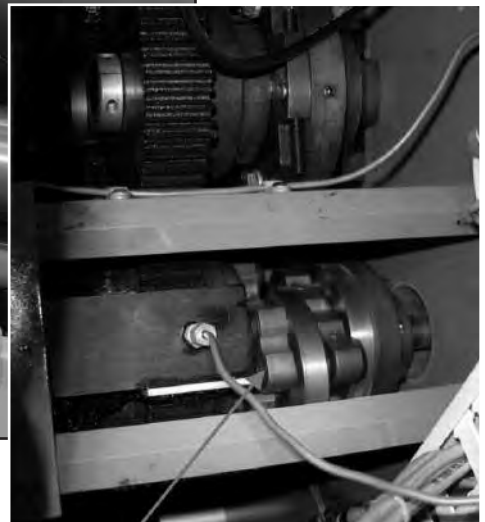
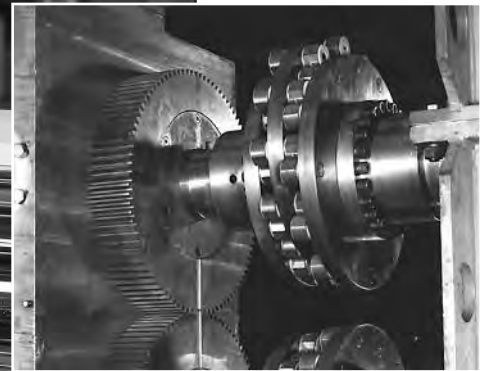

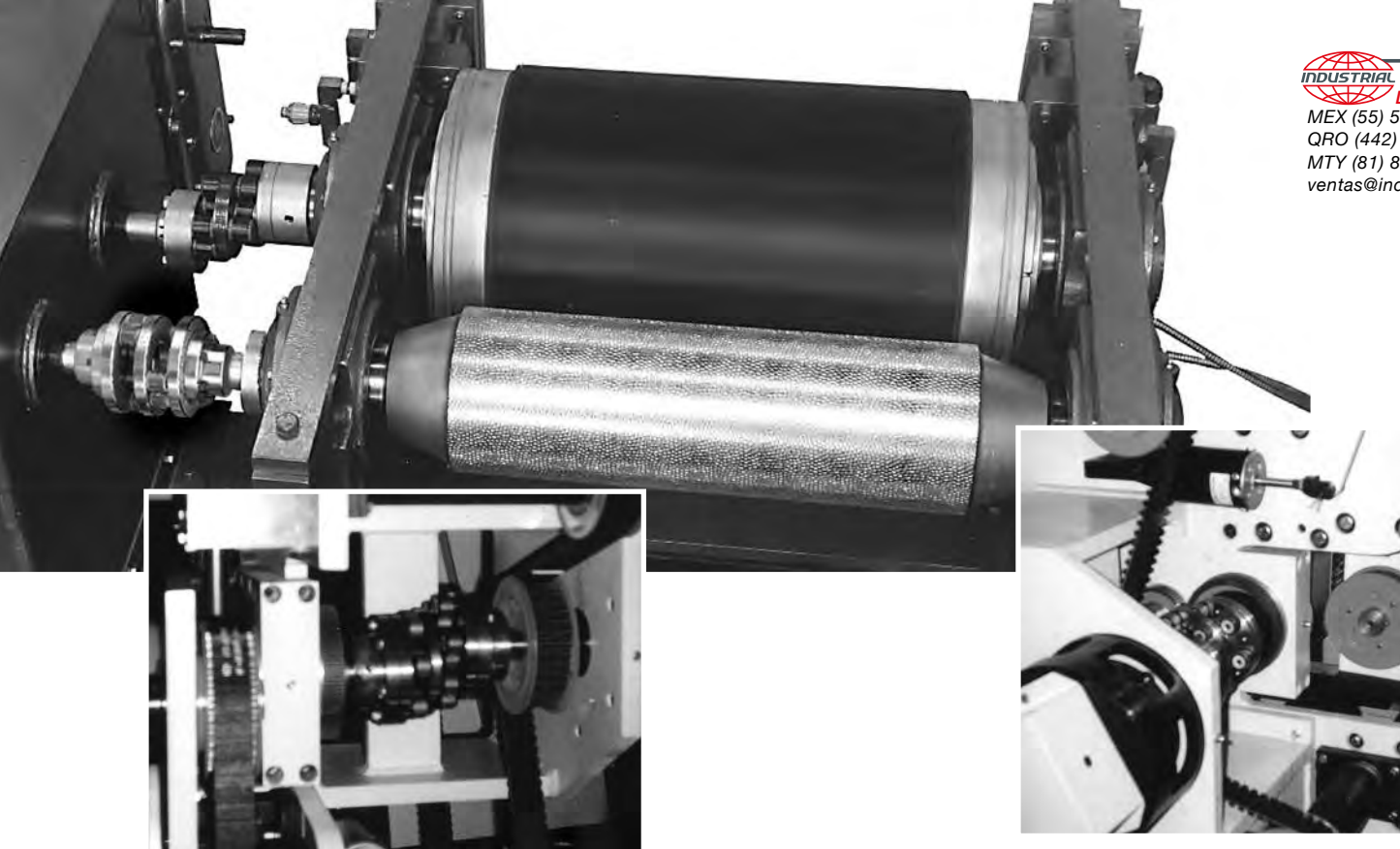

Three Schmidt styles for a wide range of applications – or ask about customizing a coupling for you.



Offset Coupling

Provides the utmost in precision for parallel offset shafts. Transmits constant angular velocity and torque in a wide range of parallel shaft misalignments. Imposes no sideloads on shafts or bearings and eliminates radial shaft vibrations. No performance loss for increasing offset. It provides large floor space savings because of its compact design. **Pages 5-7, (Hubs Page 10)**



Inline Coupling

A linkage coupling designed with high torsional stiffness, this coupling accommodates small parallel shaft misalignments at constant angular velocity. Designed as a dropout coupling, it can be easily installed and offers excellent drive performance for low to medium shaft speeds and medium to high torque applications. **Page 8, (Hubs Page 10)**



5-D Coupling

Provides parallel shaft misalignment and a $\pm 5^\circ$ angular misalignment with moderate axial shaft displacement capability. This coupling maintains constant angular velocity at all misalignment modes. Recommended for high torque, low RPM applications, the coupling has spherical roller bearings which are easy to maintain. **Page 9, (Hubs Page 10)**

How To Select L200 & L300 Schmidt Offset Couplings

Example:

Step 1. List the performance requirements

- a) Horsepower H=55 (HP)
- b) Shaft Speed N=1000 (RPM)
- c) B-10 Bearing Lifetime B-10=25000(HRS)
- d) Offset From Fixed Shaft PH=2 (INCH)
- e) Variable Offset (if required) PA=5 (INCH)

Step 2. Select a coupling with the required offset characteristics. All offset couplings have a minimum offset (S_{min}), a maximum offset (S_{max}) and a maximum linear range of shaft displacement (S_{ml}). For applications where the offset distance between shafts remains FIXED, simply select a coupling with an offset larger than S_{min} and smaller than S_{max} . For applications where the shaft offset distance VARIES during operation, select a coupling where the linear range of displacement is less than the S_{ml} . Note: At no time can the shafts be separated by more than S_{max} nor less than S_{min} . To use all of S_{ml} , X (see diagram below) must be equal to S_{min} and PH must equal $PA/2$. Consult dimension chart on page 6.

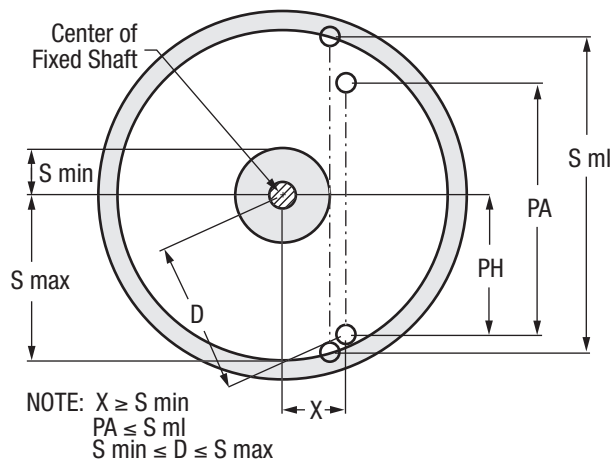

Step 3. Select the lifetime speed factor "L" from chart to the right. For N=1000 (RPM) and B10=(25000) (HRS) L=6.034

Step 4. Calculate the required performance factor $P_r = H/L = 55/6.034 = 9.115$

Step 5. Compare the required performance factor "Pr" with the coupling performance factor "P" listed on the performance data table on page 6. Select a coupling size which has an equal or higher "P" factor as "Pr". The coupling size L280C meets these requirements.

Step 6. Compare the practical speed limit (see performance data table on page 6). The data shows that the coupling size L280C can operate at 1500 RPM.

Step 7. Select hubs (if required) from chart on page 11.

Shaft Speed N (rpm)	Lifetime-Speed Factor "L"					
	B-10 Lifetime (Hours)					
	1,000	2,500	5,000	10,000	25,000	50,000
10	0.631	0.479	0.389	0.316	0.240	0.195
25	1.198	0.910	0.739	0.601	0.456	0.371
50	1.947	1.479	1.201	0.976	0.741	0.601
100	3.162	2.402	1.951	1.585	1.204	0.978
150	4.200	3.191	2.502	2.105	1.599	1.299
200	5.137	3.902	3.170	2.575	1.956	1.589
250	6.011	4.562	3.706	3.010	2.287	1.857
300	6.823	5.183	4.210	3.420	2.598	2.110
400	8.345	6.340	5.149	4.182	3.177	2.581
500	9.756	7.411	6.020	4.889	3.714	3.017
600	11.08	8.420	6.839	5.555	4.220	3.428
700	12.34	9.379	7.618	6.188	4.700	3.818
800	13.56	10.30	8.365	6.795	5.161	4.192
900	14.72	11.18	9.084	7.378	5.605	4.553
1,000	15.85	12.04	9.779	7.943	6.034	4.901
1,100	16.94	12.87	10.45	8.491	6.450	5.391
1,200	18.01	13.68	11.11	9.025	6.856	5.568
1,300	19.04	14.47	11.75	9.545	7.250	5.889
1,400	20.06	15.24	12.38	10.05	7.636	6.203
1,500	21.05	15.99	12.99	10.55	8.015	6.510
1,600	22.02	16.73	13.59	11.04	8.385	6.810
1,700	22.98	17.45	14.18	11.52	8.748	7.106
1,800	23.92	18.17	14.76	11.99	9.105	7.396
1,900	24.84	18.87	15.33	12.45	9.456	7.681
2,000	25.75	19.56	15.89	12.90	9.803	7.962
2,100	26.64	20.24	16.44	13.35	10.14	8.238
2,200	27.52	20.91	16.98	13.79	10.48	8.511
2,300	28.39	21.57	17.52	14.23	10.81	8.780
2,400	29.25	22.22	18.05	14.66	11.14	9.046
2,500	30.10	22.86	18.57	15.08	11.46	9.308

The L200 & L300 Series couplings use needle bearings. The B-10 lifetime on the bearing is considered the life of the coupling, assuming that the bearing is the weakest part in the coupling. The lifetime-speed factor accounts for the B-10 lifetime and shaft speed.

SCHMIDT L200 & 300 SERIES OFFSET COUPLINGS

INDUSTRIAL MAGZA
 DIST. AUTORIZADO
 MEX (55) 53 63 23 31
 QRO (442) 1 95 72 60
 MTY (81) 83 54 10 18
 ventas@industrialmagza.com

Performance Data

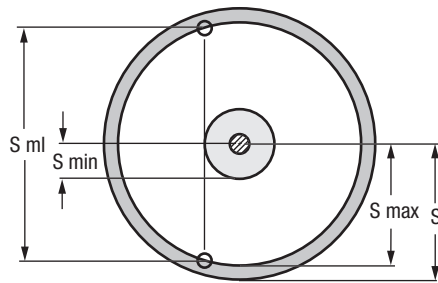
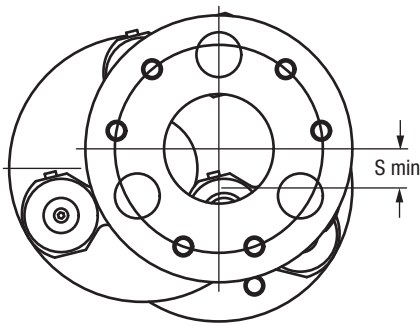

Recommended operational area for shaft displacement

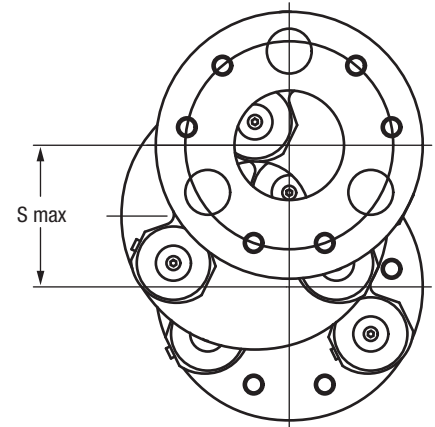

Coupling Designation	Performance Data									
	Part No.	Shaft Displacements				Angular (In)*	Performance Factor P	Max. Torque Capacity (In-Lbs)*	Practical Speed Limit (rpm)**	Coupling Weight (Lb)
S (In)		S min (In)	S max (In)	S ml (In)						
L230C	1.75	0.437	1.575	3.026	0.020	0.186	637	2,500	2	2
L234C						0.878	3,000	2,000	6	9
L239C						1.465	5,000	2,000	7	17
L246C						2.285	7,800	2,000	9	31
L253C						3.222	11,000	2,000	11	50
L259C	3.50	0.87	3.15	6.05	0.025	5.272	18,000	1,750	30	155
L270C						8.787	30,000	1,750	39	297
L280C						13.035	44,500	1,500	47	496
L290C						18.160	62,000	1,250	55	770
L281C						10.691	36,500	1,250	65	608
L289C	4.50	1.12	4.05	7.78	0.025	16.549	56,500	1,250	77	948
L210C						24.605	84,000	1,000	96	616
L211C						34.856	119,000	1,000	112	2,594
L214C						60.633	207,000	1,000	171	6,049
L217C						93.732	320,000	1,000	223	11,917
L220C	4.00	1.00	3.60	6.92	0.025	134.446	459,000	750	273	20,913
L350C						1.465	5,000	2,500	10	36
L355C						2.255	7,700	2,500	12	55
L360C						1.845	6,300	2,000	12	70
L375C						6.883	23,500	1,750	45	360
L385C	7.00	1.75	6.30	12.10	0.025	8.143	27,800	1,750	57	583
L310C	7.00	1.75	6.30	12.10		13.767	47,000	1,250	95	1,368
L312C	10.00	2.50	9.00	17.29		17.135	58,500	1,000	129	2,594

*The torque capacity of the Schmidt Coupling is primarily a function of the bearing size, the number of bearings and the torque radius of the coupling.

These design parameters are expressed by the performance factor P.

**If shaft speed requirement is higher than the practical speed limit consult our engineering department.

SCHMIDT L200 & 300 SERIES OFFSET COUPLINGS

INDUSTRIAL MAGZA
 DIST. AUTORIZADO
 MEX (55) 53 63 23 31
 QRO (442) 1 95 72 60
 MTY (81) 83 54 10 18
 ventas@industrialmagza.com

Dimension Data

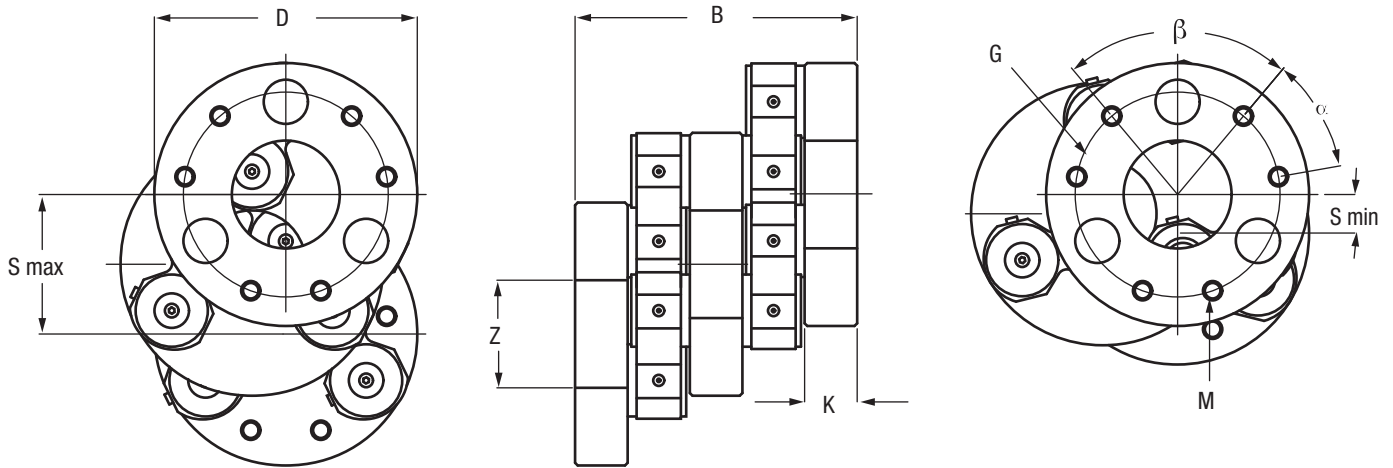

Coupling Designation	Dimension Data									
	Coupling		End Disc Assembly Data							
Part No.	D (In)	B ±.032 (In)	Z (In)	K (In)	G (In)	M (In)	Number of Bolts	α (°)	β (°)	Bolt Size (In)
L230C	3.00	2.75	1.280	0.380	2.187	8-32	6	40	80	8-32 Fl. Hd.
L234C	3.37	3.81	1.375	0.60	2.750	5/16-18	6	40	80	5/16-18x1
L239C	3.93		1.937		3.000		4	90	90	
L246C	4.62		2.625		3.750		5	72	72	
L253C	5.25		3.250		4.375		6	60	60	
L259C	5.94	6.37	2.437	1.19	4.625	7/16-14	6	40	80	7/16-14x1.75
L270C	7.00		3.500		5.625		4	90	90	
L280C	8.00		4.500		6.625		5	72	72	
L290C	9.00		5.500		7.625		6	60	60	
L281C	8.00	7.62	3.500	1.44	6.500	5/8-11	6	40	80	5/8-11x2
L289C	8.90		4.375		7.375		4	90	90	
L210C	10.20		5.500		8.500		5	72	72	
L211C	11.60		7.000		10.000		6	60	60	
L214C	14.41	7.62	9.500	1.44	12.625	3/4-10	8	45	45	3/4-10x2.25
L217C	17.31		12.000		15.500		10	36	36	
L220C	20.25		14.500		18.250		12	30	30	
L350C	5.00	3.81	1.375	0.60	2.750	5/16-18	6	40	80	5/16-18x1
L355C	5.56		1.625							
L360C	6.00		1.375							
L375C	7.50	6.37	2.437	1.19	4.625	7/16-14	6	40	80	7/16-14x2
L385C	8.50		2.437							
L310C	10.00	7.62	3.500	1.44	6.500	5/8-11	6	40	80	5/8-11x2
L312C	11.80		3.500							

SCHMIDT **L400 SERIES** INLINE COUPLINGS

INDUSTRIAL MAGZA
 DIST. AUTORIZADO
 MEX (55) 53 63 23 31
 QRO (442) 1 95 72 60
 MTY (81) 83 54 10 18
 ventas@industrialmagza.com

Schmidt Inline Couplings - L400 Series

Schmidt Inline Couplings are a torque-rigid type, designed with two pairs of parallel links installed 90 degrees out of phase with each other. This linkage arrangement allows for the precise transmission of torque and constant angular velocity between shafts with small to moderate parallel misalignments. The coupling utilizes needle bearings which can be preloaded for Low and Ultra Low backlash conditions. Where backlash is not as critical, non-lubricated filament wound teflon bearings are available for higher torque capacity and where relubrication of the coupling is difficult.

Typical applications which benefit from the high accuracy provided by Schmidt Inline Couplings are feeders, embossers, compactors, printing presses and many others.

Schmidt Inline Couplings are available for a torque range from 500 to 35,000 inch-pounds. Couplings for higher torque requirements are made available on special orders.



End View

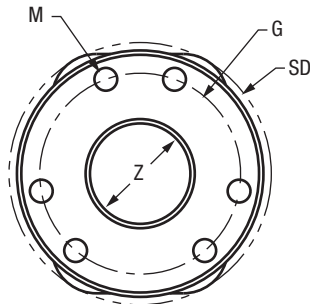

Side View

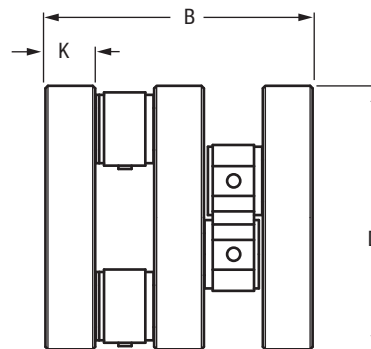

Dimensions and Performance Data of Inline Couplings

Coupling Designation		L4xxC or L4xxD Series*							
		L431C/D	L442C/D	L436C/D	L448C/D	L463C/D	L485C/D	L481C/D	L411C/D
Performance Capacity	HP/100 rpm**	0.88	1.35	3.17	5.08	19.04	29.51	36.49	56.49
	Torque (In x Lb)**	550	850	2,000	3,200	12,000	18,600	23,000	35,600
	Displacement	Parallel* (In)	0.06	0.06	0.06	0.06	0.06	0.06	0.06
Angular (°)		±0.5	±0.5	±0.5	±0.5	±0.5	±0.5	±0.5	±0.5
Coupling Dimensions (In.)	Disc Diameter D	3.098	4.190	3.613	4.863	6.286	8.475	8.129	10.943
	Swing Diameter SD	3.23	4.32	3.70	4.95	6.44	8.63	8.33	11.14
	Coupling Length B	3.156	3.156	3.810	3.810	6.373	6.373	7.623	7.623
	Disc Width K	0.500	0.500	0.600	0.600	1.187	1.187	1.437	1.437
	Center Bore Dia Z	1.500	1.812	1.625	2.562	2.875	4.000	3.625	5.500
	Bolt Circle G	2.412	2.412	3.000	3.000	5.000	5.000	7.000	7.000
	No. of Bolts and Size M	3 1/4"-20	3 1/4"-20	6 1/4"-20	6 1/4"-20	6 1/2"-13	6 1/2"-13	8 5/8"-11	8 5/8"-11
Net Weight (Lb)	3.1	5.1	5.6	7.8	32.0	47.0	64.2	93.2	
Inertia Wk ² (Lb-In ²)	6.7	18.6	10.2	29.7	178.7	534.0	604.0	1,783	

Notes: *Data apply to shaft speed under 1800 RPM. Greater parallel misalignment is possible at lower RPM. Consult factory.
 **LC Series Inline Couplings are equipped with needle bearings. LD Series Inline Couplings are equipped with filament wound teflon bearings for 20% higher torque capacities than shown above.

SCHMIDT **L500 SERIES** 5-D COUPLINGS

INDUSTRIAL MAGZA
 DIST. AUTORIZADO
 MEX (55) 53 63 23 31
 QRO (442) 1 95 72 60
 MTY (81) 83 54 10 18
 ventas@industrialmagza.com

Schmidt 5-D Couplings - L500 Series



Schmidt 5-D Couplings were developed to fill a gap in the family of torque-rigid couplings. Most couplings in the Schmidt Coupling line are designed to accommodate either axial, angular, or parallel shaft displacements only. For some applications, however, the operational conditions require all possible shaft misalignments. If these shaft misalignments exceed the limit of the selected coupling capacity, excess sideloads are introduced into the equipment which can cause vibrations, life reduction or failure of vital machine components such as bearings, motors, etc.

The 5-D Couplings are a modification of the Schmidt Inline Coupling, designed to accommodate 5 degrees of angular shaft misalignment. This coupling allows easy adjustment to any possible misaligned shaft position without imposing heavy sideloads on shafts, bearings or other machine equipment. Schmidt 5-D Couplings offer large shaft misalignment capabilities and constant angular velocity. The acting forces within the coupling can be precisely calculated, assuring a sound coupling design which is especially important for heavy-duty applications. To select a 5-D Coupling, follow the same procedure as the Inline on the preceding page.

End View

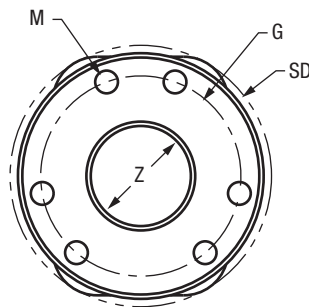

Side View

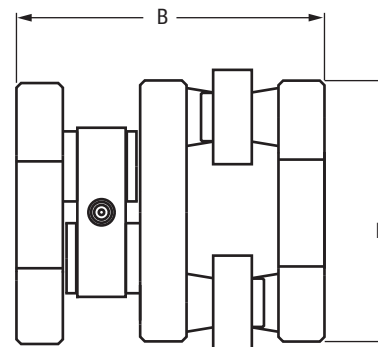

Dimensions and Performance Data of 5-D Couplings

Coupling Designation*		L5xxS Series*									
		L536S**	L558S**	L564S	L585S	L582S	L511S	L514S	L517S	L519S	L526S
Performance Capacity	HP/100 rpm	4.44	9.52	20.3	31.4	46.5	71.8	136	211	373	793
	Torque (In - Lb)	2,800	6,000	12,800	19,800	29,300	45,300	86,000	133,000	235,000	500,000
	Displacement	Parallel (In)	3/16	3/16	1/4	1/4	3/8	3/8	7/16	7/16	1
Angular (°)		±5	±5	±5	±5	±5	±5	±5	±5	±5	±5
Coupling Dimensions (In.)	Disc Diameter D	3.38	5.63	6.25	8.38	8.00	10.75	13.25	16.38	19.25	25.13
	Swing Diameter SD	3.60	5.82	6.36	8.55	8.21	11.03	13.52	16.52	19.88	26.28
	Coupling Length B	4.18	4.18	5.38	5.38	7.23	7.23	8.70	12.75	13.75	15.00
	Center Bore Dia Z	1.375	3.25	3.25	2.44	3.50	4.38	7.00	6.75	7.25	10.00
	Bolt Circle G	2.75	4.38	4.38	4.63	6.63	6.50	10.00	13.50	16.88	21.75
	No. of Bolts and Size M	6 5/16"-18	6 5/16"-18	6 5/16"-18	6 7/16"-14	5 5/8"-11	6 5/8"-11	6 3/4"-10	12 3/4"-10	12 7/8"-9	12 1"-8
Net Weight (Lb)		6	10	21	38	52	86	139	345	577	1,205
Inertia Wk ² (Lb-In ²)		7	26	77	281	331	1,050	2,290	8,615	22,000	70,350
*Other sizes available for special applications. **Sealed bearings not available Note: Data applies to shaft speeds under 1,000 RPM. For higher RPM, please consult factory		Consult Factory									

SCHMIDT **HUBS** FOR **200 - 500 SERIES** COUPLINGS

INDUSTRIAL MAGZA
 DIST. AUTORIZADO
 MEX (55) 53 63 23 31
 QRO (442) 1 95 72 60
 MTY (81) 83 54 10 18
 ventas@industrialmagza.com

- Standard Hub Data For Schmidt Couplings
- Typical shaft/hub configurations determined by amount of axial shaft separation.

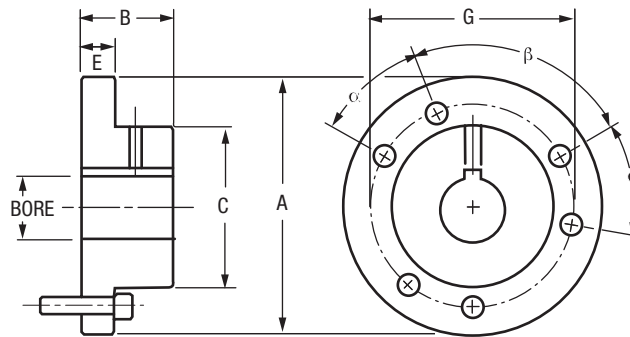

Used on Coupling		Hub Part No.	Hub Dimensions (Inch)									Wt. (Lbs)
L200	L300		A	B	C	E	Max Bore†	G	Number & Size of Fasteners	α	β	
L230C		S6025XX	2.812	1.000	1.750	0.500	1.125	2.188	(6) #8-32 x 3/4	40°	80°	1.2
L234C	L350C L355C L360C	S6027XX	3.375	1.250	2.000	0.687	1.250	2.750	(6) 5/16-18 x 1	40°	80°	2.2
L239C		S6030XX	3.938	1.500	2.250	0.687	1.500	3.000	(4) 5/16-18 x 1	90°	90°	3.2
L246C		S6031XX	4.625	1.750	3.000	0.687	2.000	3.750	(5) 5/16-18 x 1	72°	72°	5.3
L253C		S6032XX	5.250	1.875	3.625	0.687	2.500	4.375	(6) 5/16-18 x 1	60°	60°	7.6
L259C	L375C L385C	S6033XX	5.938	2.125	3.750	0.750	2.500	4.625	(6) 7/16-14 x 1-3/4	40°	80°	10.1
L270C		S6035XX	7.000	2.500	4.375	1.000	3.000	5.625	(4) 5/8-11 x 2	90°	90°	17.2
L280C		S6039XX	8.000	2.875	5.375	1.000	3.750	6.625	(5) 5/8-11 x 2	72°	72°	26.1
L290C		S6042XX	9.000	3.375	6.375	1.000	4.500	7.625	(6) 5/8-11 x 2	60°	60°	39.5
L281C	L375C L385C	S6038XX	8.000	3.250	5.250	1.000	3.500	6.500	(6) 5/8-11 x 2	40°	80°	28.0
L289C		S6040XX	8.900	3.500	6.000	1.250	4.125	7.375	(4) 3/4-10 x 2-1/4	90°	90°	39.8
L210C		S6043XX	10.000	4.000	7.125	1.250	5.250	8.500	(5) 3/4-10 x 2-1/4	72°	72°	58.6
L211C		S6044XX	11.600	4.500	8.625	1.250	6.375	10.000	(6) 3/4-10 x 2-1/4	60°	60°	90.4
L214C												
L217C												
L220C												
Contact Factory												

†Please specify bore and keyway size.

Standard Hub Data for Inline and 5-D Couplings (Inch)											
Used on Coupling	Hub Part No.	A	B	C	E	Max Bore†	G	Number & Size of Fasteners	α	β	Hub Wts. Net Lbs.
L431C/D L442C/D	S6026XX	3.000	1.250	3.000	1.250	1.500	2.412	(3) 1/4-20 x 1	120°	120°	2.5
L436C/D L448C/D*	S6029XX	3.613	1.750	2.500	0.687	1.750	3.000	(6) 1/4-20 x 1-1/4	60°	60°	3.4
L463C/D L485C/D*	S6034XX	6.250	3.000	3.937	1.000	2.625	5.000	(6) 1/2-13 x 2	60°	60°	15.5
L481C/D L411C/D*	S6037XX	8.125	4.000	5.437	1.250	3.500	7.000	(8) 5/8-11 x 2-1/4	45°	45°	36.4
L536S	S6027XX	3.375	1.250	2.000	0.687	1.250	2.750	(6) 5/16-18 x 1	40°	80°	2.2
L558S L564S	S6032XX	5.250	1.875	3.625	0.687	2.500	4.375	(6) 5/16-18 x 1	60°	60°	7.6
L585S	S6033XX	5.938	2.125	3.750	0.750	2.500	4.625	(6) 7/16-14 x 1-3/4	40°	80°	10.1
L582S	S6039XX	8.000	2.875	5.375	1.000	3.750	6.625	(5) 5/8-11 x 2	72°	72°	26.1
L511S	S6038XX	8.000	3.250	5.250	1.000	3.500	6.500	(6) 5/8-11 x 2	40°	80°	28.0
L514S	S6044XX	11.600	4.500	8.625	1.250	6.375	10.000	(6) 3/4-10 x 2-1/4	60°	60°	90.4

†Please specify bore and keyway size.

*Only these sizes will accept an inverted hub configuration to reduce axial length.



Standard Keyways - Inch Bore Hubs

Bore Size		Keyway	Bore Size		Keyway
Over	To		Over	To	
0.437	0.562	0.125x0.062	2.250	2.750	0.625x0.312
0.562	0.875	0.187x0.094	2.750	3.250	0.750x0.375
0.875	1.250	0.250x0.125	3.250	3.750	0.875x0.437
1.250	1.375	0.312x0.156	3.750	4.500	1.000x0.500
1.375	1.750	0.375x0.187	4.500	5.500	1.250x0.625
1.750	2.250	0.500x0.250	5.500	6.500	1.500x0.750

Standard Keyways - Metric Bore Hubs

Bore Size		Keyway	Bore Size		Keyway
Over	To		Over	To	
10	12	4x1.8	58	65	18x4.4
12	17	5x2.3	65	75	20x4.9
17	22	6x2.8	75	85	22x5.4
22	30	8x3.3	85	95	25x5.4
30	38	10x3.3	95	110	28x6.4
38	44	12x3.3	110	130	32x7.4
44	50	14x3.8	130	150	36x8.4
50	58	16x4.3	150	170	40x9.4

Note: Inch bore hubs will be supplied with inch size setscrews. Metric bore hubs will be supplied with metric size setscrews. Standard keyways are for square keys. Keyways for rectangular keys are available - consult factory.

Bore Tolerances

Nominal		Bore Tolerance			
Shaft Diameter		Class 1		Interference	
Over	To	Clearance Fit		Fit	
0.437	1.500	-0.000	+0.001	-0.001	-0.0005
1.500	2.000	-0.000	+0.001	-0.002	-0.001
2.000	3.000	-0.000	+0.0015	-0.002	-0.001
3.000	4.000	-0.000	+0.0015	-0.003	-0.0015
4.000	5.000	-0.000	+0.002	-0.0035	-0.002
5.000	6.000	-0.000	+0.002	-0.004	-0.0025

Based on nominal shaft diameter (AGMA Standard 511.02) Clearance Fit Standard. Metric hub bores will be supplied with H7 clearance fit as standard. S7 interference fit available.

How To Select An Inline or 5-D Coupling

Selection Formula

$$(HP/100 \text{ RPM}) = \frac{(\text{Required HP}) \times (\text{Service Factor}) \times 100}{\text{RPM}}$$

Selection Formula Example

Required HP = 100 at 1750 RPM and 1.5 Service Factor

$$(HP/100 \text{ RPM}) = \frac{100 \times 1.5 \times 100}{1750} = 8.57$$

Look for a coupling size which as a HP/100 RPM rating equal or greater than the required 8.57. For this example the coupling size L463C with a HP/100 RPM rating of 19.04 can be selected. If the backlash requirement is not critical the coupling L463D, which does not require any further lubrication, can be chosen.

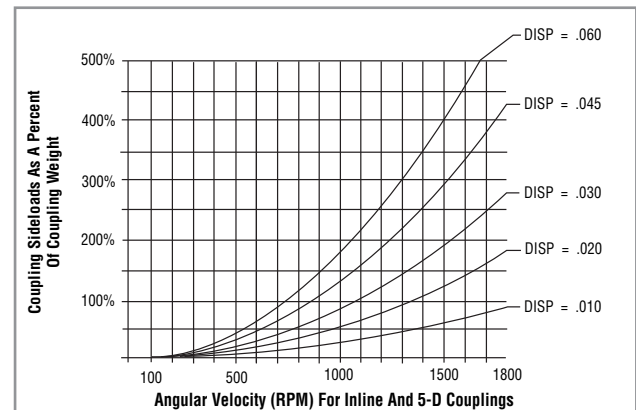

The graph shows the InLine /5D coupling's reaction to parallel misalignment. Machinery sensitive to sideload forces generated by the coupling may require closer shaft alignment. Machinery not sensitive to sideload forces may allow for more misalignment than shown in the dimension and performance data tables.

Service Factor Guide

Uniform	1.0
Light Shock	1.5
Medium Shock	2.0
Heavy Shock	2.5

The service factors listed are intended only as a general guide. For typical service factors used in various applications, refer to "AGMA Standard-Lc classification and Service Factors For Flexible Couplings" (AGMA 514.02).

Zero-Max Configurable 3D CAD Downloads

New Zero-Max Configurable
 3D CAD Downloads.
www.zero-max.com/3D





ServoClass® Couplings
www.zero-max.com/servo



ETP® Bushings
www.zero-max.com/etp



CD® Couplings
www.zero-max.com/cd

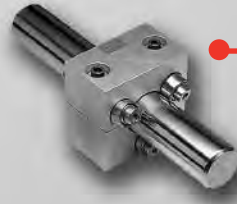

Roh'lix® Linear Actuators
www.zero-max.com/rohlix



Schmidt Offset Couplings
www.zero-max.com/offset



Zero-Max® Adjustable Speed Drives
www.zero-max.com/drives



Torq-Tender®
www.zero-max.com/torqtender



Crown Right Angle Gear Drives
www.zero-max.com/crown



Control-Flex® Couplings
www.zero-max.com/controlflex



OHLA® Overhung Load Adapters
www.zero-max.com/ohla

Warranty. Zero-Max, Inc. the manufacturer, warrants that for a period of 12 months from date of shipment it will repair, or at its option, replace any new apparatus which proves defective in material or workmanship, or which does not conform to applicable drawings and specifications approved by the manufacturer. All repairs and replacements shall be F.O.B. factory. All claims must be made in writing to the manufacturer. • In no event and under no circumstances shall manufacturer be liable for (a) damages in shipment; (b) failures or damages due to misuse, abuse, improper installation or abnormal conditions of temperature, dirt, water or corrosives; (c) failures due to operation, intentional or otherwise, above rated capacities, and (d) non-authorized expenses for removal, inspection, transportation, repair or rework. Nor shall manufacturer ever be liable for consequential and incidental damages, or in any amount greater than the purchase price of the apparatus. • Zero Max, Inc. reserves the right to discontinue models or to change specifications at any time without notice. No discontinuance or change shall create any liability on the part of Zero-Max, Inc. in respect to its products in the hands of customers or products on order not incorporating such changes even though delivered after any such change. • This warranty is in LIEU OF ALL OTHER WARRANTIES, EXPRESS OR IMPLIED, INCLUDING (BUT NOT LIMITED TO) ANY IMPLIED WARRANTIES OF MERCHANTABILITY OR FITNESS FOR A PARTICULAR PURPOSE. THE TERMS OF THIS WARRANTY CONSTITUTE ALL BUYER'S OR USER'S SOLE AND EXCLUSIVE REMEDY, AND ARE IN LIEU OF ANY RIGHT TO RECOVER FOR NEGLIGENCE, BREACH OF WARRANTY, STRICT TORT LIABILITY OR UPON ANY OTHER THEORY. Any legal proceedings arising out of the sale or use of this apparatus must be commenced within 18 months of the date of purchase. • CAUTION: Rotating equipment must be guarded. Also refer to OSHA specifications and recommendations. • Zero-Max®, CD®, ETP®, ServoClass®, Torq-Tender®, Control-Flex®, Posi-Lok® and Roh Lix® are registered trademarks of Zero-Max, Inc. In U.S.A. OHLA™ is a trademark of Zero-Max, Inc.

© Zero-Max 2008 Printed in U.S.A.