



MEX (55) 53 63 23 31    MTY (81) 83 54 10 18  
QRO (442) 1 95 72 60    [ventas@industrialmagza.com](mailto:ventas@industrialmagza.com)

# **////// ZERO-MAX<sup>®</sup> Control Flex<sup>®</sup> Couplings**



**Ideal for encoders**, Control-Flex® Couplings are available with clamp-style zero backlash hubs or in a drop-out design for easy flexible disc changeout.

The Control-Flex® Coupling was developed to satisfy today's higher performance requirements. To meet this goal, Zero-Max engineered a unique Control-Flex® Disc which is based on a parallel linkage system.

Because of this unique design, the reaction forces due to transmission of torque and unavoidable shaft misalignments are considerably smaller when compared with common flexible couplings.



The Control-Flex® Disc allows parallel, angular and axial shaft misalignments, and maintaining constant transmission of torque and angular velocity.

Ideal for Encoder Applications!

## Outstanding Features and Benefits

Feature	Benefit
High parallel, angular and axial shaft misalignment capabilities with considerably less sideloads on shaft bearings, seals.	Increases lifetime of other machine components.
Zero backlash design.	Required for precision drives.
Electrically insulating flex element.	Increases lifetime of other machine components.
Low weight and inertia.	Reduced power requirements.
Clamp-Style.	Zero backlash for precision drives.

# SINGLE DISC CONTROL-FLEX® COUPLINGS

## Clamp-Style

The construction of a Control-Flex® Coupling consists of two hubs (to be attached to the shafts) and a center flex member. This flexible element is affixed to the hubs through pins. Clamp-style hubs provide a positive shaft connection. Special modifications are available upon request.

The clamp-style Control-Flex® Couplings are available with a single flex disc for standard torque capacity, or with two flex discs for increased torque capacity and torsional stiffness. The clamp-style hub models come standard without keyways. Keyways are available upon request.



- Ideal for encoder Applications
- Easy Installation
- Space Saving
- Electrically Insulating
- Ultra low reaction loads
- Zero Backlash
- Maintenance Free

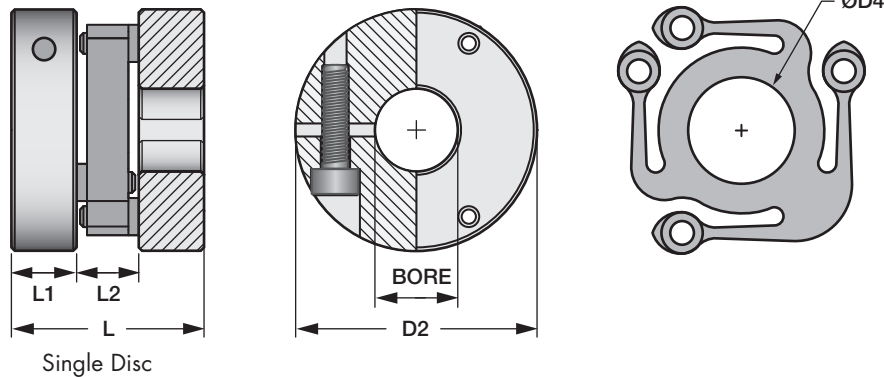

### Single Flex Disc Clamp-Style

Part No.	Coupling Dimensions							Performance Data								Maximum Shaft Misalignments		
	CPL. Diam (Inch) D2	Coupling Length (Inch) L	Hub Length (Inch) L1	Max Bore		Disc Inside Diam (Inch) D4	Disc Length (Inch) L2	Net Weight (Lb)	Inertia WK <sup>2</sup> (Lb-In <sup>2</sup> )	Max. Peak Torque (In-Lb)	Max. Cont. Peak Torque (In-Lb)	Torsional Stiffness			Max Speed (RPM)	Par (Inch)	Ang (Deg)	Axial (Inch)
				(Inch)	(mm)							In Lbs. Per Degree	In Lbs. Per Radian	In Oz. Per Minute				
C008P	0.748	0.62	0.219	0.375	10	0.28	0.19	0.020	0.0014	6	4	2.3	130	0.61	12,000	0.013	1.5	0.010
C011P	0.984	1.00	0.374	0.500	12	0.31	0.25	0.057	0.0075	13	9	5.0	285	1.33	11,000	0.019	1.5	0.014
C016P	1.457	1.17	0.394	0.750	19	0.56	0.38	0.135	0.038	45	31	16.3	930	4.35	8,000	0.028	1.5	0.021
C023P	2.205	1.74	0.591	1.188	30	0.84	0.56	0.450	0.291	152	106	55.0	3,150	14.29	6,000	0.041	1.5	0.031
C031P	2.953	2.17	0.709	1.500	40	1.13	0.75	1.060	1.220	361	250	75.0	4,300	20.00	5,000	0.055	1.5	0.042

1) Maximum speed rating applicable at 50% or less continuous torque rating.  
 2) As speeds approach the maximum speed rating, some applications may require dynamically balanced couplings.

## Clamp-Style

The construction of a Control-Flex® Coupling consists of two hubs (to be attached to the shafts) and a center flex member. This flexible element is affixed to the hubs through pins. Clamp-style hubs provide a positive shaft connection. Special modifications are available upon request.

The clamp-style Control-Flex® Couplings are available with a single flex disc for standard torque capacity, or with two flex discs for increased torque capacity and torsional stiffness. The clamp-style hub models come standard without keyways. Keyways are available upon request.



- Ideal for encoder Applications
- Easy Installation
- Space Saving
- Electrically Insulating
- Ultra low reaction loads
- Zero Backlash
- Maintenance Free

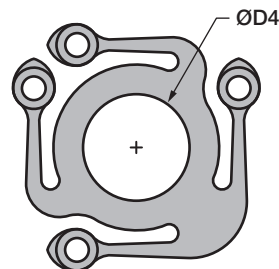
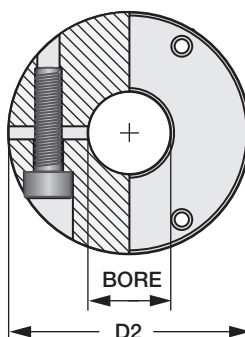
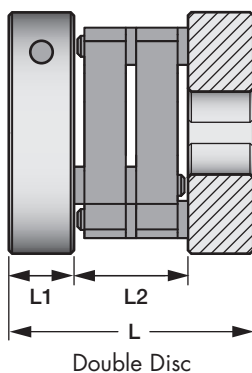

### Double Flex Disc Clamp-Style

Part No.	Coupling Dimensions							Performance Data								Maximum Shaft Misalignments		
	CPL Diam (Inch) D2	Coupling Length (Inch) L	Hub Length (Inch) L1	Max Bore		Disc Inside Diam (Inch) D4	Disc Length (Inch) L2	Net Weight (Lb)	Inertia WK <sup>2</sup> (Lb-In <sup>2</sup> )	Max. Peak Torque (In-Lb)	Max. Cont. Peak Torque (In-Lb)	Torsional Stiffness			Max Speed (RPM)	Par (Inch)	Ang (Deg)	Axial (Inch)
				(Inch)	(mm)							In Lbs. Per Degree	In Lbs. Per Radian	In Oz. Per Minute				
C208P	0.748	0.78	0.219	0.375	10	0.28	0.34	0.021	0.0014	10	7	4.6	260	1.22	10,000	0.009	1	0.007
C211P	0.984	1.20	0.374	0.500	12	0.31	0.46	0.060	0.0077	24	17	9.9	570	2.63	9,000	0.012	1	0.009
C216P	1.457	1.48	0.394	0.750	19	0.56	0.69	0.145	0.039	81	57	31.3	1,790	8.33	7,000	0.019	1	0.014
C223P	2.205	2.20	0.591	1.188	30	0.84	1.02	0.483	0.298	274	192	110.0	6,300	29.41	5,000	0.027	1	0.020
C231P	2.953	2.79	0.709	1.500	40	1.13	1.38	1.140	1.250	650	435	150.0	8,600	40.00	4,000	0.037	1	0.028

1) Maximum speed rating applicable at 50% or less continuous torque rating.

2) As speeds approach the maximum speed rating, some applications may require dynamically balanced couplings.

## Bolted-Style

The construction of a Control-Flex® Coupling consists of two hubs (to be attached to the shafts) and a center flex member. This flexible element is affixed to the hubs through shoulder bolts. The Bolted-Style hubs incorporate keyway and setscrew shaft attachment. Flex discs are bolted for drop-out capability. Special modifications are available upon request.

- Easy Installation
- Space Saving
- Electrically Insulating
- Large Misalignment Capacity
- Zero Backlash
- Maintenance Free

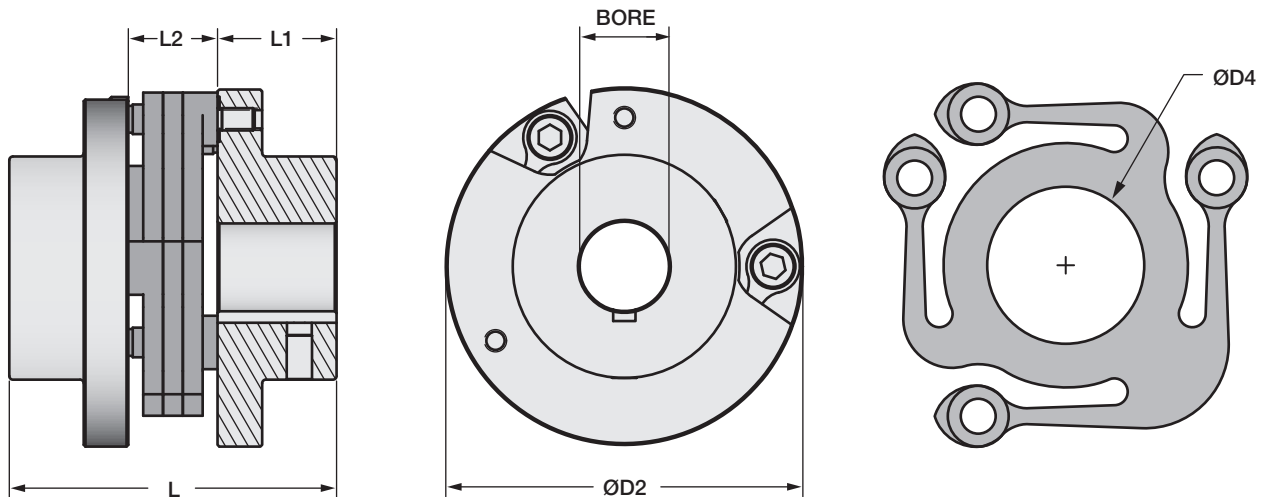

The above drawing is valid for C030P, C060P and C075P. C045P will still use the triangular style hubs. Consult factory if necessary.

Control-Flex Coupling Bolted-Style																	
Part No.	Coupling Dimensions							Performance Data							Maximum Shaft Misalignments		
	CPL. Diam (Inch) D2	Coupling Length (Inch) L	Hub Length (Inch) L1	Max Bore		Disc Inside Diam (Inch) D4	Disc Length (Inch) L2	Net Weight (Lb)	Inertia WK <sup>2</sup> (Lb-In <sup>2</sup> )	Max. Peak Torque (In-Lb)	Max. Cont. Peak Torque (In-Lb)	Torsional Stiffness		Max Speed (RPM)	Par (Inch)	Ang (Deg)	Axial (Inch)
				(Inch)	(mm)							In Lbs. Per Degree	In Lbs. Per Radian				
C030P	3.00	2.750	1.00	1.000	25	1.125	0.750	0.78	0.345	361	250	75.0	4,300	6,300	0.055	1.5	0.042
C045P	4.50	4.125	1.50	1.500	40	1.687	1.125	2.63	2.62	1,218	850	261.0	14,950	4,200	0.083	1.5	0.063
C060P	6.00	5.500	2.00	2.000	55	2.250	1.500	6.24	11.03	2,887	2,000	515.0	29,500	3,100	0.111	1.5	0.083
C075P	7.50	6.875	2.50	2.500	65	2.812	1.875	12.18	33.66	5,638	3,900	1,529.0	87,600	2,500	0.139	1.5	0.104

1) Maximum speed rating applicable at 50% or less continuous torque rating.  
 2) As speeds approach the maximum speed rating, some applications may require dynamically balanced couplings.

# SCHMIDT *FLEXIBLE* COUPLINGS

Schmidt Flexible Couplings provide precision for slightly misaligned shafts and are designed to adapt to various drive conditions. This coupling uses precision sintered parts for the hubs which are connected to the shafts. The molded flexible center disc is preloaded on the precision shafts of the end disc which give the coupling a zero backlash condition. Different configurations of the coupling and the choice of three durometers (soft, standard, stiff) of the center disc result in the ability of this coupling to be adapted to various drive conditions.

The Flexible Coupling may be built into a floating shaft design by including one coupling at each end of an intermediate shaft.

- Easy Installation
- Electrically Insulating
- Zero Backlash

Among the many applications where the Flexible Couplings are used include collators, printing machines, packaging machines and pumps.



Double Disc Spacer  
 Single Disc  
 Double Disc

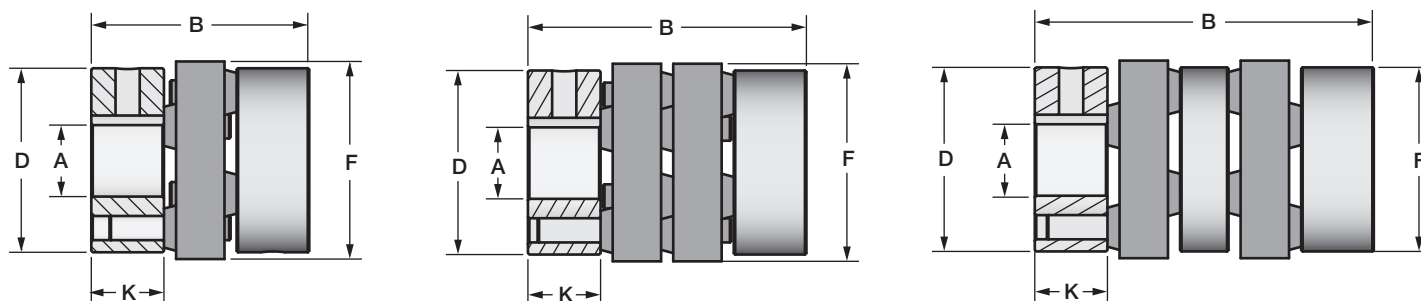
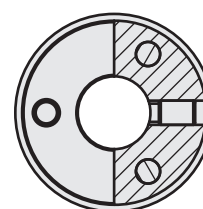

## Schmidt Flexible Couplings

Part No.	Coupling Dimensions						Performance Data								
	Hub Diam (Inch) D	Coupling Length (Inch) B	Hub Length (Inch) K	Max Bore A		Flex. Disc Diam (Inch) F	HP/100RPM	Max. Torque (In-Lb)	Torsional Stiffness (In-Lbs. Per Degree)	Maximum Misalignments			Inertia WK <sup>2</sup> (Lb-In <sup>2</sup> )	Net Weight (Lb)	
				(Inch)	(mm)					Par (Inch)	Ang (Deg)	Axial (Inch)			
Single Disc	F008A	0.750	0.812	0.281	0.375	10	0.750	0.009	6	4.5	0.005	1	0.008	0.004	0.06
	F011A	1.125	1.375	0.500	0.500	12	1.250	0.025	16	14.0	0.008	1	0.011	0.04	0.25
	F019A	1.900	2.250	0.750	0.875	22	2.040	0.180	115	91.0	0.010	1	0.019	0.46	1.03
	F028A	2.812	2.812	1.000	1.00	25	2.812	0.500	315	264.6	0.010	1	0.025	2.50	2.50
Double Disc	F008B	0.750	0.837	0.281	0.375	10	0.750	0.018	12	9.0	0.005	1	0.008	0.005	0.07
	F011B	1.125	1.688	0.500	0.500	12	1.250	0.050	32	27.0	0.008	1	0.011	0.04	0.27
	F019B	1.900	2.875	0.750	0.875	22	2.040	0.360	230	214.1	0.010	1	0.019	0.55	1.12
	F028B	2.812	3.375	1.000	1.00	25	2.812	1.000	630	531.5	0.010	1	0.025	2.27	2.80
Double Disc Spacer	F011C	1.125	2.125	0.500	0.500	12	1.250	0.025	16	7.0	0.016	2	0.020	0.05	0.34
	F019C	1.900	3.500	0.750	0.875	22	2.040	0.180	115	45.5	0.020	2	0.035	0.66	1.47

Performance Data is based on couplings using standard durometer flex disks.  
 Please contact the factory for performance data and availability of couplings using non-standard durometers.

# HOW TO SELECT CONTROL-FLEX® COUPLINGS

## Here's how:

The basic performance ratings listed in the table are maximum values. The graph below must be used to determine the coupling's suitability in each application.

To see if a coupling is suitable for an application, see the selection procedure on this page.

When calculating torque requirements, see the service factor table provided on this page.

For special designs or requirements, consult the factory.

## Selection Procedure:

To select the proper Control-Flex® coupling size, identify the application's requirements for torque, misalignment, and service factor. Tentatively select a coupling based on these requirements. Find the selected coupling's maximum rated torque and misalignment.

Compute the misalignment ratio by dividing the required parallel misalignment by the maximum rated parallel misalignment. If either angular or axial misalignment are required, multiply the existing misalignment ratio by 1.2. If both angular and axial misalignment are required, multiply the misalignment ratio by 1.4.

Next, compute the torque ratio. Divide the required torque including service factor by the maximum rated peak torque of the selected coupling. The actual running torque should never exceed the maximum continuous rated torque. Occasional torque spikes in the system should never exceed the maximum peak torque rating.

Now that the torque and misalignment ratios are known, their effect on the coupling can be compared to the couplings operating envelope. (See Chart)

If the lines representing the two performance ratios meet to the left of the shaded area, the selected coupling is appropriate for the application.

If the lines meet in the shaded area, the selected coupling is not appropriate for the application, and a larger coupling size must be selected.

## Selection Formula:

$$\text{HP}/100 \text{ RPM} = \frac{\text{Required HP} \times \text{Service Factor} \times 100}{\text{RPM}}$$

## Recommended Service Factor

- No Shock Load . . . . .1.0
- Light Shock Load . . . . .1.5
- Medium Shock Load . . .2.0
- Heavy Shock Load . . .2.5
- Reversing Shock Load .3.0

## CONTROL FLEX® COUPLING OPERATING ENVELOPE

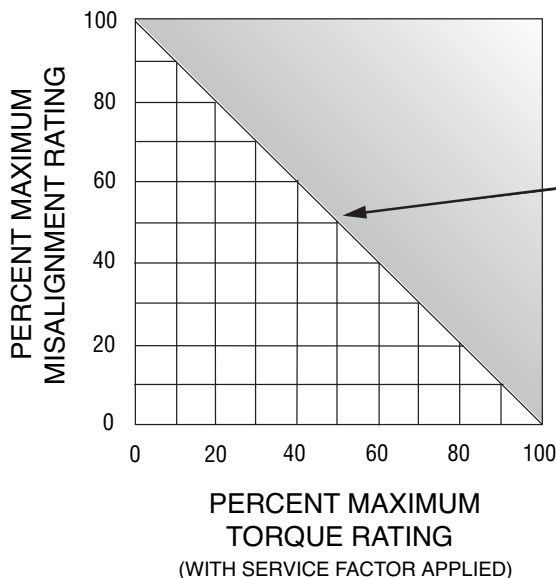

Applications falling in the shaded area are outside the couplings capability. Select the next larger coupling and repeat selection procedure.

## Standard Keyways - Inch Bore Hubs

Bore Size		Keyway	Bore Size		Keyway
Over	To		Over	To	
0.437	0.562	0.125x0.062	2.250	2.750	0.625x0.312
0.562	0.875	0.187x0.094	2.750	3.250	0.750x0.375
0.875	1.250	0.250x0.125	3.250	3.750	0.875x0.437
1.250	1.375	0.312x0.156	3.750	4.500	1.000x0.500
1.375	1.750	0.375x0.187	4.500	5.500	1.250x0.625
1.750	2.250	0.500x0.250	5.500	6.500	1.500x0.750

## Standard Keyways - Metric Bore Hubs

Bore Size		Keyway	Bore Size		Keyway
Over	To		Over	To	
10	12	4x1.8	58	65	18x4.4
12	17	5x2.3	65	75	20x4.9
17	22	6x2.8	75	85	22x5.4
22	30	8x3.3	85	95	25x5.4
30	38	10x3.3	95	110	28x6.4
38	44	12x3.3	110	130	32x7.4
44	50	14x3.8	130	150	36x8.4
50	58	16x4.3	150	170	40x9.4

Note: Inch bore hubs will be supplied with inch size setscrews. Metric bore hubs will be supplied with metric size setscrews. Standard keyways are for square keys. Keyways for rectangular keys are available - consult factory.

## Zero-Max Configurable 3D CAD Downloads

New Zero-Max Configurable 3D CAD Downloads.  
[www.zero-max.com/3D](http://www.zero-max.com/3D)





**ServoClass® Couplings**

[www.zero-max.com/servo](http://www.zero-max.com/servo)



**ETP® Bushings**

[www.zero-max.com/etp](http://www.zero-max.com/etp)



**CD® Couplings**

[www.zero-max.com/cd](http://www.zero-max.com/cd)

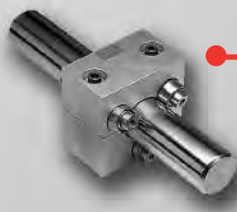

**Roh'lix® Linear Actuators**

[www.zero-max.com/rohlix](http://www.zero-max.com/rohlix)



**Schmidt Offset Couplings**

[www.zero-max.com/offset](http://www.zero-max.com/offset)

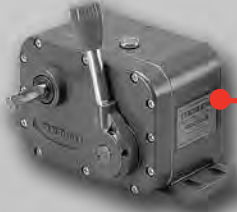

**Zero-Max® Adjustable Speed Drives**

[www.zero-max.com/drives](http://www.zero-max.com/drives)



**Torq-Tender®**

[www.zero-max.com/torqtender](http://www.zero-max.com/torqtender)



**Crown Right Angle Gear Drives**

[www.zero-max.com/crown](http://www.zero-max.com/crown)

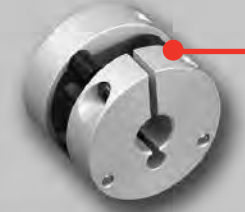

**Control-Flex® Couplings**

[www.zero-max.com/controlflex](http://www.zero-max.com/controlflex)



**OHLA® Overhung Load Adapters**

[www.zero-max.com/ohla](http://www.zero-max.com/ohla)

Warranty. Zero-Max, Inc. the manufacturer, warrants that for a period of 12 months from date of shipment it will repair, or at its option, replace any new apparatus which proves defective in material or workmanship, or which does not conform to applicable drawings and specifications approved by the manufacturer. All repairs and replacements shall be F.O.B. factory. All claims must be made in writing to the manufacturer. ● In no event and under no circumstances shall manufacturer be liable for (a) damages in shipment; (b) failures or damages due to misuse, abuse, improper installation or abnormal conditions of temperature, dirt, water or corrosives; (c) failures due to operation, intentional or otherwise, above rated capacities, and (d) non-authorized expenses for removal, inspection, transportation, repair or rework. Nor shall manufacturer ever be liable for consequential and incidental damages, or in any amount greater than the purchase price of the apparatus. ● Zero Max, Inc. reserves the right to discontinue models or to change specifications at any time without notice. No discontinuance or change shall create any liability on the part of Zero-Max, Inc. in respect to its products in the hands of customers or products on order not incorporating such changes even though delivered after any such change. ● This warranty is in LIEU OF ALL OTHER WARRANTIES, EXPRESS OR IMPLIED, INCLUDING (BUT NOT LIMITED TO) ANY IMPLIED WARRANTIES OF MERCHANTABILITY OR FITNESS FOR A PARTICULAR PURPOSE. THE TERMS OF THIS WARRANTY CONSTITUTE ALL BUYER'S OR USER'S SOLE AND EXCLUSIVE REMEDY, AND ARE IN LIEU OF ANY RIGHT TO RECOVER FOR NEGLIGENCE, BREACH OF WARRANTY, STRICT TORT LIABILITY OR UPON ANY OTHER THEORY. Any legal proceedings arising out of the sale or use of this apparatus must be commenced within 18 months of the date of purchase. ● CAUTION: Rotating equipment must be guarded. Also refer to OSHA specifications and recommendations. ● Zero-Max®, CD®, ETP®, ServoClass®, Torq-Tender®, Control-Flex®, Posi-Lok® and Roh Lix® are registered trademarks of Zero-Max, Inc. In U.S.A. OHLA™ is a trademark of Zero-Max, Inc. © Zero-Max 2008 Printed in U.S.A.