

CBC-400 Series & CBC-450 Series Clutch/Brake Controls

P-239-23
819-0500

Installation & Operating Instructions



CBC-400



CBC-450



An Altra Industrial Motion Company

Contents

Introduction	2	Switching Inputs	11
Specifications	3	Alternate/Simultaneous, Three Wire, Sinking	14
Installation	5	Alternate/Simultaneous, Two Wire, Sinking	23
Basic Connection	5	Alternate/Simultaneous, Three Wire, Sourcing	32
Control Mounting	6	Alternate/Simultaneous, Two Wire, Sourcing	41
Clutch/Brake and Power Wiring		Start-up and Check-Out	50
CBC-400	7	System Troubleshooting	51
CBC-450	9	Reorder Information	51
		Declaration of Conformity	52
		Mounting Dimensional Cut-Outs	53
		Warranty	BC

⚠ WARNING

Failure to follow these instructions may result in product damage, equipment damage, and serious or fatal injury to personnel.

Introduction

The Warner Electric CBC-400 and CBC-450 series clutch/brake controls are compact units designed for operation with any of the Warner Electric 24VDC and 90VDC clutches and brakes. These controls supply full nominal voltage to the magnets for on-off applications.

These controls can be configured via jumper to operate alternately between channel 1 and channel 2 or simultaneously both channels on or off at the same time. These controls can operate a single clutch or brake, two clutches, two brakes or a combination clutch/brake.

Solid state optically isolated switching allows for maximum flexibility in interfacing to customers' switching requirements. This allows for using either the internal supply voltage or on external supply voltage for full isolation. Because the inputs are optically coupled, switching can be done by switches, relays or solid state devices that can be sinking (NPN) or sourcing (PNP).

Additionally, the control has an input line fuse to provide protection in the event of a short on the output or overloads. Internal circuitry provides suppression of turn-off transients when the magnets are switched to aid in the decay of the magnetic field so faster cycle rates may be

obtained. LED indicators on the control board provide a visual indication as to which output is active.

Transformer input is provided on the CBC-450 series controls extending the operating AC input voltages. Four models are available:

- CBC-400-24 24-30 VAC input, 24VDC output
- CBC-400-90 120 VAC input, 90VDC output
- CBC-450-24 120/220/240/380/480 VAC input, 24 VDC Output
- CBC-450-90 120/220/240/380/480 VAC input, 90VDC Output

Specifications:

Input/Output:

- CBC-400-24: 24-30 VAC input, 50/60 Hz, 1 phase, 250 VA max. Nominal 24VDC full-wave rectified output, 5.0 Amps per channel, 5.0 Amps max. total.
- CBC-400-90: 120 VAC input \pm 10%, 50/60 Hz, 1 phase, 250 VA max. Nominal 90 VDC full-wave rectified output, 250 VA max. 1.0 Amp per channel, 2.0 Amps max. total.
- CBC-450-24: 120/220/240/380/480 VAC input \pm 10%, 50/60 Hz, 1 phase, 250 VA max. Nominal 24VDC full-wave rectified output. 4.0 Amps per channel 4.0 Amps max. total.
- CBC-450-90: 120/220/240/380/480 VAC input \pm 10%, 50/60 Hz, 1 phase, 250 VA max. Nominal 90 VDC full-wave rectified output, 250 VA max., 1.0 Amp per channel, 1.2 Amps max. total.

Circuit Protection: (fusing)

- CBC-400-24: 6.3 amp, 250 V fast-blo, 5 x 20 mm
- CBC-400-90: 2.5 amp, 250 V fast-blo, 3AG
- CBC-450-24: 5 amp, 125 V fast-blo, 5 x 20 mm
- CBC-450-90: 1.5 amp, 250 V fast-blo, 3AG

Switching Inputs: (external to control, supplied by customer)

Three optically isolated switching inputs for customer supplied switching. Operating voltage range 10-30 VDC, external voltage or 12VDC auxiliary power on control:

Inputs: Channel 1, Channel 2 and Channel 2 override.

Input Switching Time: 2 milliseconds minimum

Maximum off-state leakage < 1 ma

OPTO Current: 2.8ma@10VDC per input
 8.8ma@30VDC per input
 3.4ma@12VDC Internal Source

Operation Selector:

Jumper (selectable single or dual output mode)

Ambient Temperature:

-20° to 122°F (-29° to 50°C)

Auxiliary Power Supply:

12 VDC, 250 ma maximum.
 For external switches or sensors.

NOTE: When internal 12VDC Power supply is used, inputs are no longer isolated from control DC common. Isolation is maintained only when external DC supply is used for opto-coupler power.

Certifications:



Enclosure:

Optional NEMA 13 enclosure available
 Part Number 6042-101-004 CBC-400
 Part Number 6046-101-007 CBC-450

Fusing:

- CBC-400-24 6.3AMP, 250V Fast-acting 5x20mm, P/N 458-8001-089
- CBC-400-90 2.5AMP, 250V Fast-acting, 3AG, P/N 458-8001-024
- CBC-450-24 5AMP, 250V Fast-acting 5x20mm, P/N 458-8001-088
- CBC-450-90 1.5AMP, 250V Fast-acting, 3AG, P/N 458-8001-020

CBC 400/450 Installation/Operation Manual Flow Diagram

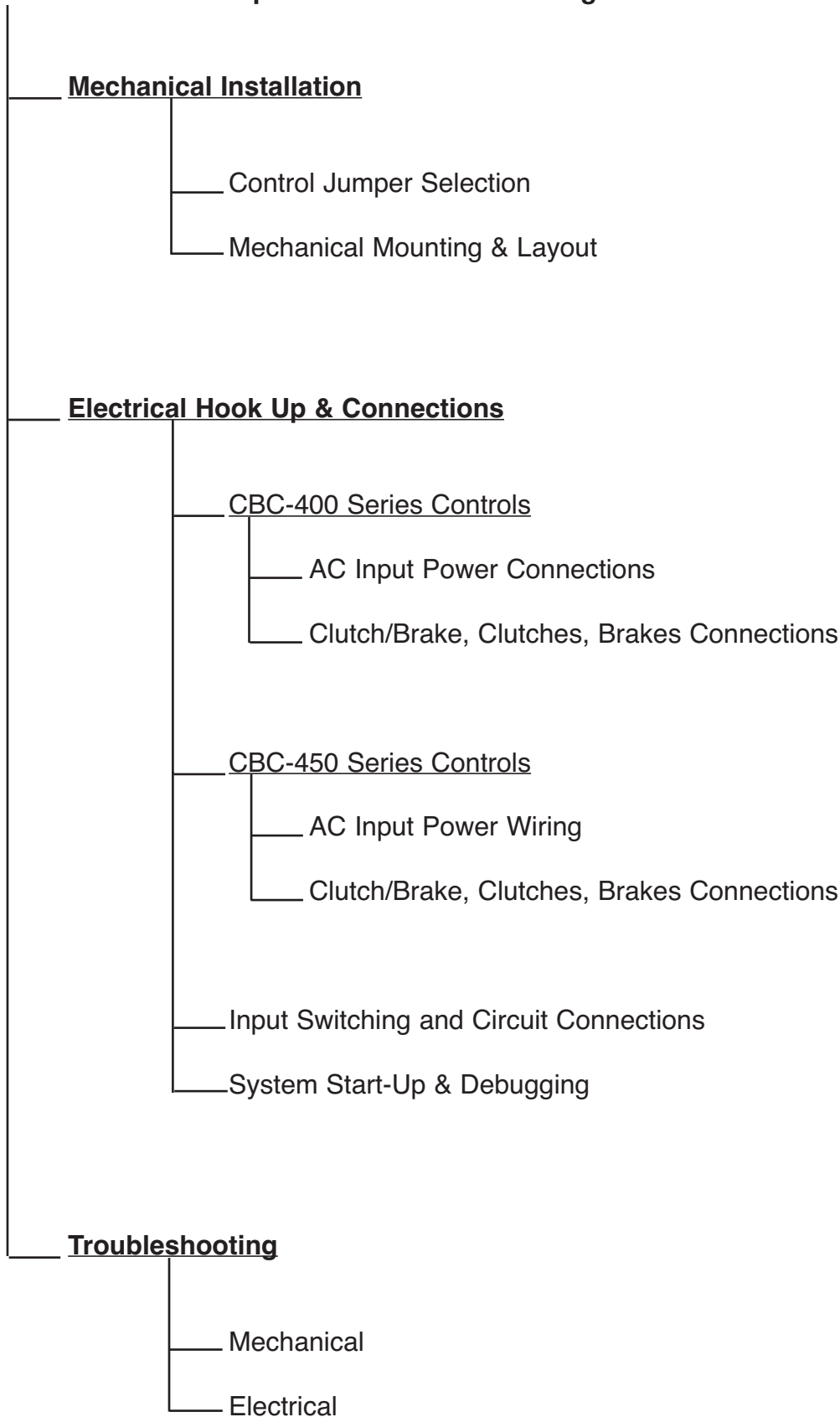

Installation

⚠ WARNING The voltages present in this control can cause serious injury (even death). When installing this control or any electrical equipment, make certain that the input power is off. Do not apply power to this control until it is securely mounted and completely wired in accordance with local codes and all installation work, including cleanup, has been completed.

Connection Diagrams

CBC-400 Series

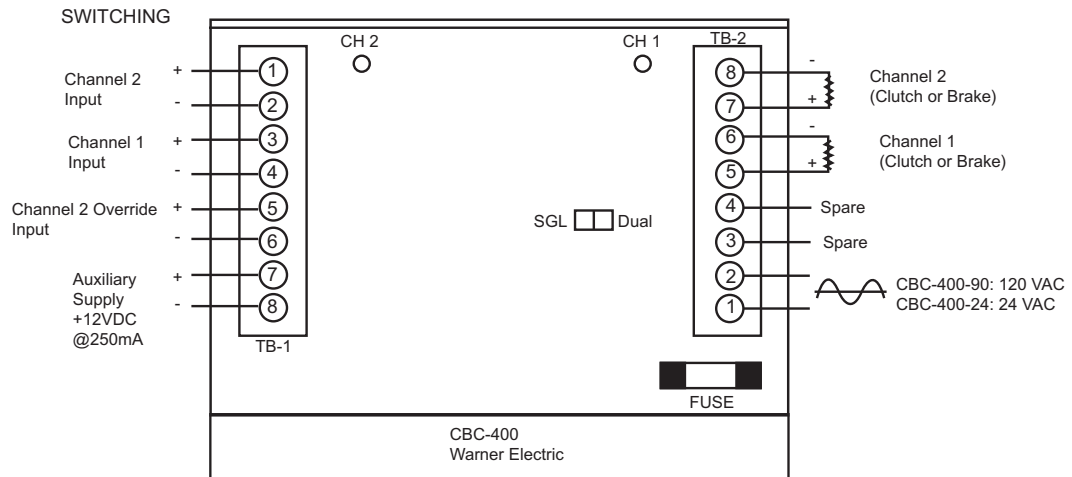

Figure 1

CBC-450 Series

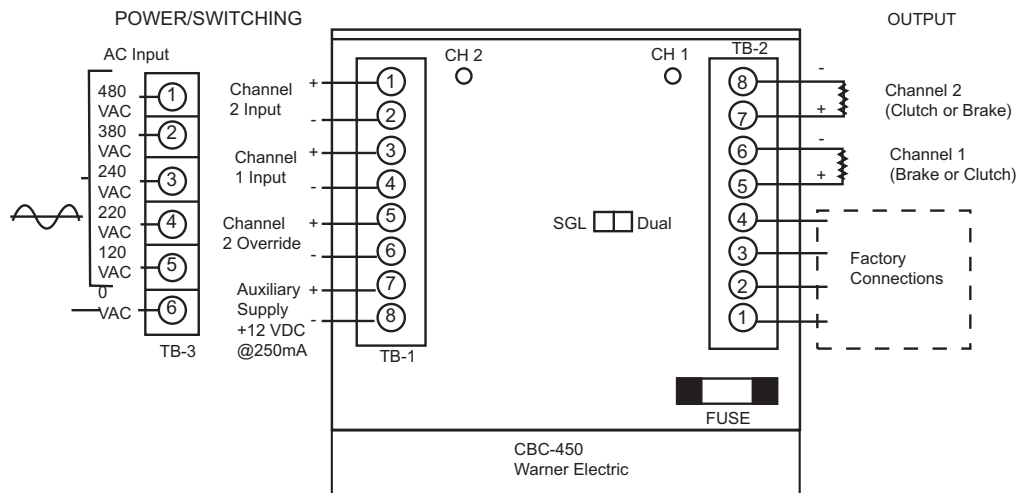

Figure 2

Jumper Selection

The CBC-400/CBC-450 controls can be operated in one of two modes either alternate (single) channel operation or simultaneous (dual) mode of operation. In the single mode (alternate) of operation, channels 1 and 2 function alternately, one channel on at a time. In the dual mode (simultaneous) of operation, both channels 1 and 2 function simultaneously, both on or both off at the same time.

In the alternate mode (single) at power up with no inputs active (all switching circuits open or off) channel 1 is the active output.

In the simultaneous mode (dual) at power up with no inputs active (all switching circuits open or off) both channel 1 and channel 2 outputs are inactive or off.

Mode Selection

- For single channel (alternate) operation, make sure jumper is on the single side of the connection block.

NOTE: The control is shipped with the jumper placed in the single mode operating position.

- For simultaneous mode (dual) operation, remove the jumper from the pins and reinstall on the dual side of the connector block.

Control Mounting

- 1. Select the appropriate location to where the control will be mounted. Insure sufficient air space is maintained around and above the control selected.
- 2. Using the dimensions of Figure 3 or Figure 4 depending on whether the CBC-400-XX or CBC-450-XX is to be used, layout the dimensions on the location selected or use the cut-out template of Figure 5 or 6. (See page 53.)

NOTE: Insure that sufficient space is available to accommodate wiring runs.

- 3. If using the cut-out template Figure 5 or 6, tape template to location where control is to be mounted. Using a center punch, mark the four (4) mounting holes.

NOTE: Insure sufficient force is used so punch marks are visible in panel when the template is removed.

- 4. Drill the mounting holes using a #21 drill.
- 5. Tap the mounting holes using a 10-32 tap. Make sure holes are free of burns and rough edges.
- 6. Using 10-32 screws with lockwashers, secure the control to the panel or chassis securely.

NOTE: Make sure screws are tightened with sufficient torque since control may be subjected to light to moderate vibration on most machine applications.

- 7. After mounting control, make sure area around control and wiring run location are clean and free of chips, shavings, etc. before proceeding to wiring section.
- 8. Double check to insure sufficient space around and above control. Insure cover or door assembly does not contact control board when closed.

CBC-400

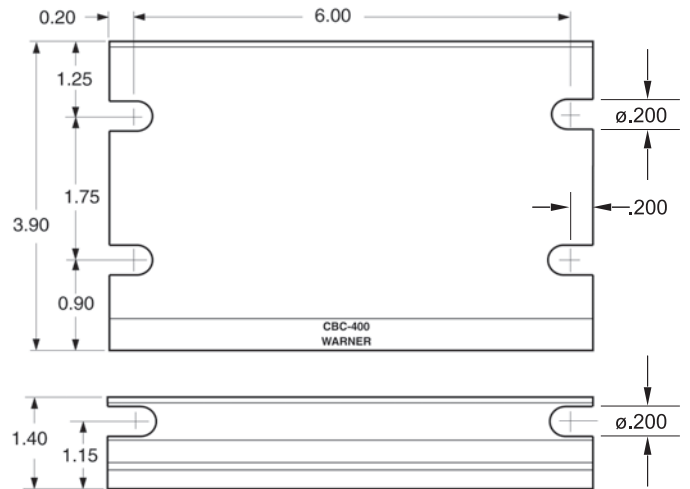

This control may be mounted on its base (two mounting slots) or on its back (four mounting slots). NOTE: All dimensions nominal.

Figure 3

CBC-450

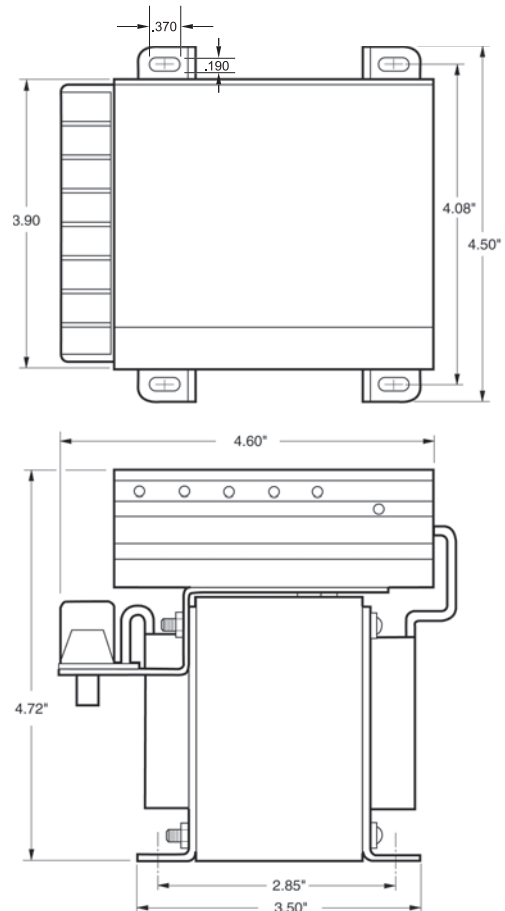

Figure 4

Wiring Installation

CBC-400 Clutch/Brake and Power Wiring

⚠ WARNING Make certain AC input power is off before making any wiring connections. Observe any and all lock out procedures so established by any local or national codes. Failure to do so could cause serious injury (even death).

- 1. Connect the hot line of the AC power source to terminal 1 of TB-2 and tighten screw securely.
 - a. 120 VAC for CBC-400-90
 - b. 24-30 VAC for CBC-400-24
- 2. Connect the neutral line of the AC power source to terminal 2 of TB-2 and tighten screw securely.
 - a. 120 VAC neutral for CBC-400-90
 - b. 24-30 VAC neutral for CBC-400-24
- 3. Based on mode jumper selection under initial installation, determine if clutch-brake combination, two clutches, or two brakes will be used. Proceed to that section for appropriate wiring instructions.
- 4. Connections for alternate mode (single) operation.
 - a. Clutch/Brake Combination
 - 1. Connect brake to Channel 1 output, Terminals 5 and 6 on Terminal Block TB-2. Tighten terminals securely.
 - 2. Connect clutch to Channel 2 output, Terminals 7 and 8 on Terminal Block TB-2. Tighten terminals securely.
 - 3. This completes the wiring for the clutch/brake combination. Proceed to the switching input section for connection of switching input circuits.

NOTE: In alternate mode of operation (single), the control powers up with Channel 1 “on” until a switching input change occurs on the Channel 2 switching input. One or the other magnets will be energized, both units cannot be turned off simultaneously unless AC power is removed from the control.

- b. Dual Clutch Combination
 - 1. Determine which clutch is to be engaged at power-up and wire this clutch to Channel 1 output Terminals 5 and 6 on Terminal Block TB-2. Tighten terminals securely.
 - 2. Wire the second clutch to Channel 2 output Terminals 7 and 8 on Terminal Block TB-2. Tighten terminals securely.
 - 3. This completes the wiring of a dual clutch arrangement. Proceed to the switching input section for connection of switching input circuits

NOTE: In this mode of operation, one clutch or the other will be engaged. Both clutches cannot be turned off simultaneously unless AC power is removed from the control.

- c. Dual Brake Combination
 - 1. Determine which brake is to be energized at power up and wire this brake to the Channel 1 output Terminals 5 and 6 on Terminal Block TB-2. Tighten terminals securely.
 - 2. Wire the second brake to the Channel 2 output, Terminals 7 and 8 on Terminal Block TB-2. Tighten terminals securely.
 - 3. This completes the wiring of a dual brake arrangement. Proceed to the switching input section for connection of switching input circuits

NOTE: In this mode of operation, one brake or the other will be engaged. Both brakes cannot be turned off simultaneously unless AC power is removed from the control.

5. Connections for Simultaneous Mode (Dual) Operation

a. Clutch/Brake Combination

NOTE: Normally Clutch/Brake Combinations are run in alternate mode (single); however on some shaker or vibratory conveyor applications both clutch/brake may be operated simultaneously. If in doubt about your application, contact your local Warner Electric representative.

- 1. Connect clutch to Channel 2 output, Terminals 7 and 8 on Terminal Block TB-2. Tighten terminals securely.
- 2. Connect brake to Channel 1 output, Terminals 5 and 6 on Terminal Block TB-2. Tighten terminals securely.
- 3. This completes the wiring for the clutch/brake wiring. Proceed to the switching input section for connection of switching input circuits.

NOTE: In Simultaneous Mode (Dual) both output channels are off at initial control power up. When switched, both channels will be on simultaneously.

b. Dual Clutch Combination

- 1. Connect Clutch 1 to the Channel 1 output, Terminals 5 and 6 on Terminal

Block TB-2. Tighten terminals securely.

- 2. Connect Clutch 2 to the Channel 2 output, Terminals 7 and 8 on Terminal Block TB-2. Tighten terminals securely.
- 3. This completes the wiring of a dual clutch arrangement. Proceed to the switching input section for connection of switching input circuits.

NOTE: In Simultaneous Mode (Dual) both output channels are off at initial control power up. When switched, both channels will be on simultaneously.

c. Dual Brake Combination

- 1. Connect Brake 1 to the Channel 1 output, Terminals 5 and 6 on Terminal Block TB-2. Tighten terminals securely.
- 2. Connect Brake 2 to the Channel 2 output, Terminals 7 and 8 on Terminal Block TB-2. Tighten terminals securely.
- 3. This completes the wiring of a dual brake arrangement. Proceed to the switching input section for connection of switching input circuits.

NOTE: In Simultaneous Mode (Dual) both output channels are off at initial control power up. When switched, both channels will be on simultaneously.

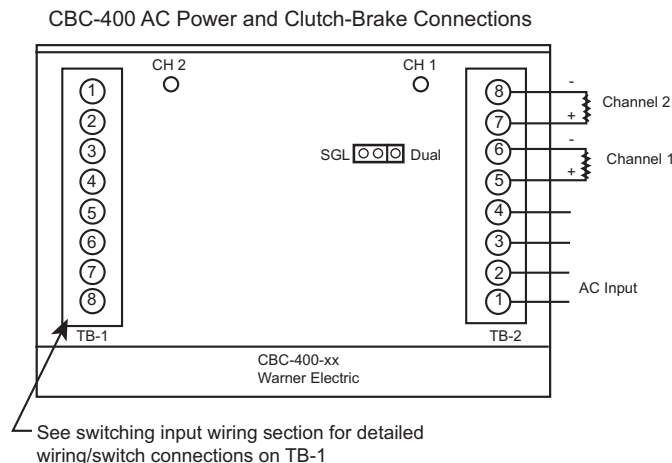

Figure 7

CBC-450 Clutch/Brake and Power Wiring

▲ WARNING Make certain AC input power is off before making any wiring connections. Observe any and all lock out procedures so established by any local or national codes. Failure to do so could cause serious injury (even death).

- 1. Connect the neutral line of the AC power source to Terminal 6 of Terminal Block TB-3. Tighten screw securely.
- 2. Connect the hot side of the AC power source as follows:
 - a. For 120 VAC, Terminal 5 of Terminal Block TB-3. Tighten terminal securely.
 - b. For 220 VAC, Terminal 4 of Terminal Block TB-3. Tighten terminal securely.
 - c. For 240 VAC, Terminal 3 of Terminal Block TB-3. Tighten terminal securely.
 - d. For 380 VAC, Terminal 2 of Terminal Block TB-3. Tighten terminal securely.
 - e. For 460 VAC, Terminal 1 of Terminal Block TB-3. Tighten terminal securely.
- 3. Based on Mode Jumper Selection under initial installation, determine if clutch/brake combination, two clutches or two brakes, will be used. Proceed to that section for appropriate wiring instructions.
- 4. Connections for Alternate Mode (Single) Operation.
 - a. Clutch/Brake Combination
 - 1. Connect brake to Channel 1 output Terminals 5 and 6 on Terminal Block TB-2. Tighten terminals securely.
 - 2. Connect clutch to Channel 2 output Terminals 7 and 8 on Terminal Block TB-2. Tighten terminals securely.
 - 3. This completes the wiring for the clutch/brake combination. Proceed to the switching input section for connection of switching input circuits.

NOTE: In alternate mode of operation (single), the control powers up with Channel 1 “on” until a switching input change occurs on the Channel 2 switching input. One or the other magnet will be engaged, both units cannot be turned off simultaneously unless AC power is removed from the control.

b. Dual Clutch Combination

- 1. Determine which clutch is to be engaged at power up and wire this clutch to the Channel 1 output Terminals 5 and 6 on Terminal Block TB-2. Tighten terminals securely.
- 2. Wire the second clutch to the Channel 2 output Terminals 7 and 8 on Terminal Block TB-2. Tighten terminals securely.
- 3. This completes the wiring of the dual clutch combination. Proceed to the switching input section for connection of switching input circuits.

NOTE: In this mode of operation, one clutch or the other will be engaged. Both clutches cannot be turned off simultaneously unless AC power is removed from the control.

c. Dual Brake Combination

- 1. Determine which brake is to be energized at power up and wire this brake to the Channel 1 output Terminals 5 and 6 of Terminal Block TB-2. Tighten terminals securely.
- 2. Wire the second brake to the Channel 2 output Terminals 7 and 8 on Terminal Block TB-2. Tighten terminals securely.
- 3. This completes the wiring of the dual brake combination. Proceed to the switching input section for connection of switching input circuits.

NOTE: In this mode of operation, one brake or the other will be engaged. Both brakes cannot be turned off simultaneously unless AC power is removed from the control.

5. Connections for Simultaneous Mode (Dual) Operation

a. Clutch/Brake Combination

NOTE: Normally, clutch/brake combinations are run in alternate mode (single) operation; however, on some shaker or vibratory conveyor applications, both clutch and brake may be operated simultaneously. If in doubt about your application, contact your local Warner Electric representative.

- 1. Connect the clutch to Channel 2 output Terminals 7 and 8 on Terminal Block TB-2. Tighten terminal securely.
- 2. Connect the brake to Channel 1 output Terminals 5 and 6 Terminal Block TB-2. Tighten terminals securely.
- 3. This completes the wiring of the clutch/brake wiring. Proceed to the switching input section for connection of the switching input circuits.

NOTE: In Simultaneous Mode (Dual), both output channels are off at initial power up. When switched, both outputs will be on simultaneously.

b. Dual Clutch Combination

- 1. Connect clutch 1 to the Channel 1 output Terminals 5 and 6 of Terminal

Block TB-2. Tighten terminals securely.

- 2. Connect clutch 2 to the Channel 2 output Terminals 7 and 8 of Terminal Block TB-2. Tighten terminals securely.
- 3. This completes the wiring for a dual clutch arrangement. Proceed to the switching input section for connections of switching input circuits.

NOTE: In Simultaneous Mode (Dual), both output channels are off at initial power up. When switched, both outputs will be on simultaneously.

c. Dual Brake Combination

- 1. Connect brake 1 to the Channel 1 output Terminals 5 and 6 of Terminal Block TB-2. Tighten terminals securely.
- 2. Connect brake 2 to the Channel 2 output Terminals 7 and 8 of Terminal Block TB-2. Tighten terminals securely.
- 3. This completes the wiring of a dual brake arrangement. Proceed to the switching input section for connection of switching input circuits.

NOTE: In Simultaneous Mode (Dual), both output channels are off at initial power up. When switched, both channels will be on simultaneously.

CBC-450 AC Power and Clutch-Brake Connections

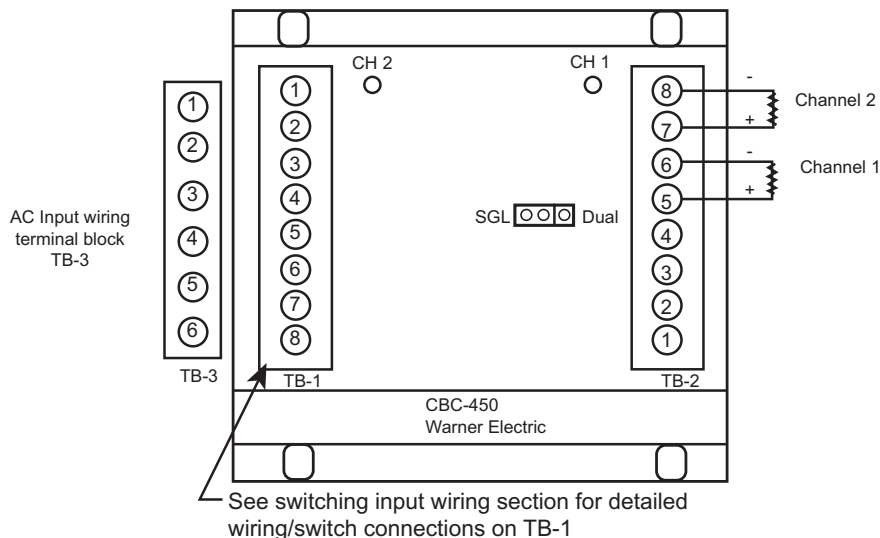

Figure 8

Input Switching CBC-400/CBC-450 Series

The CBC-400 and CBC-450 series controls employ opto-coupled inputs for switching, and as such allow for various switching input options. With the various options the controls can be operated in, this allows for replacing many of the older Warner Electric controls no longer available.

Switching on the CBC-400/CBC-450 inputs can be with mechanical switches such as push-button or maintained toggle, solid state switch such as sensors, i.e., photoelectric, and inductive or capacitive, or outputs from Programmable Logic Controllers or computer interfaces.

Because the CBC-400/CBC-450 use opto-coupled inputs, switching can be three-wire (momentary) or two-wire (maintained) configuration depending on available switches or outputs and can be either sinking or sourcing.

NOTE: Sinking input generally refers to the use of NPN type switching transistors where the load (opto-coupler) is connected between the voltage source (+) and the collector of the output switching device. The switching device is between the DC common and low side (-) input of the control.

NOTE: Sourcing input generally refers to the use of PNP type switching transistors where the load (opto-coupler) is connected between the DC common (-) and the collector of the output switching device. The switching device is between the + voltage source and the high side (+) input of the control.

Wiring the Switching Inputs

- 1. Determine operating mode
 - a. Alternate (Single)
 - b. Simultaneous (Dual)
- 2. Determine type of switching
 - a. Three-Wire (separate Channel 1, Channel 2 input switches or sensors momentary contacts) (Refer to Figures 9 & 11)
 - b. Two Wire (single input switch or sensor-maintained contacts) (Refer to Figures 10 & 12)
- 3. Determine type of switching device
 - a. Sinking (Refer to Figures 9 & 10)
 - b. Sourcing (Refer to Figures 11 & 12)
- 4. Record Type Operating Mode and Switching Scheme
 - a. _____
 Example: Alternating Mode (Single), Three Wire, Sinking
- 5. Proceed to the appropriate section for detailed switching input hook-ups and configurations.
 - Alternate/Simultaneous Mode, Three-Wire, Sinking...Page 14
 - Alternate/Simultaneous Mode, Two-Wire, Sinking...Page 23
 - Alternate/Simultaneous Mode, Three-Wire, Sourcing...Page 32
 - Alternate/Simultaneous Mode, Two-Wire, Sourcing...Page 41

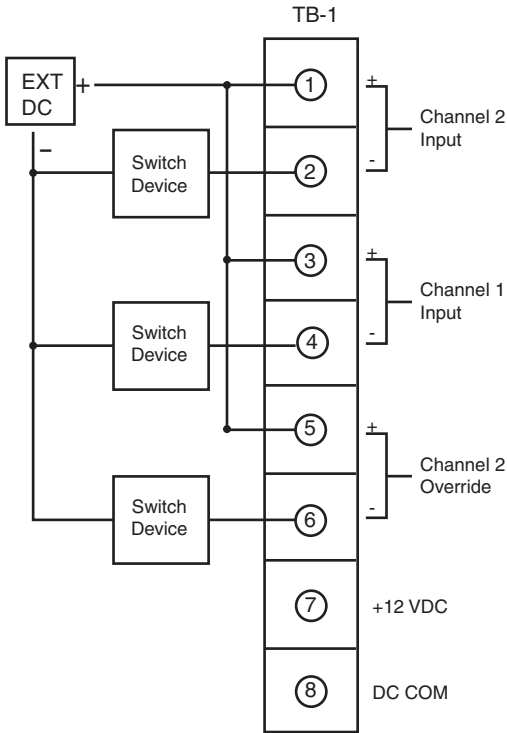

Sinking Type Device With External
 DC Power Source
 Three Wire Input (Momentary)

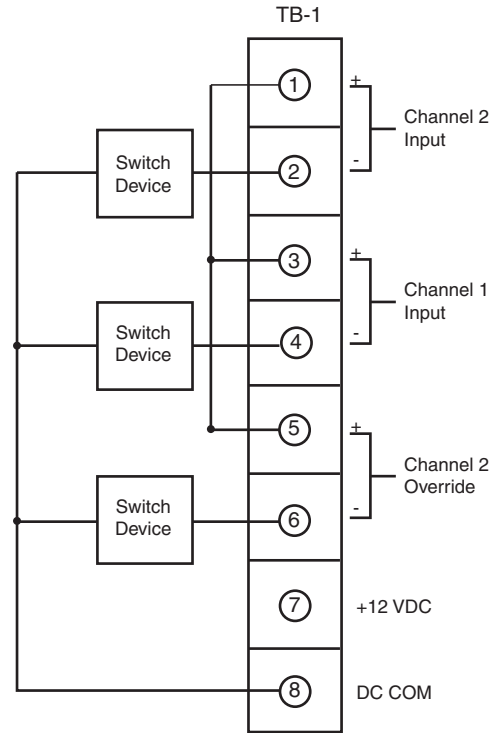

Sinking Type Device Using
 Internal DC Power Supply
 Three Wire Input (Momentary)

Figure 9

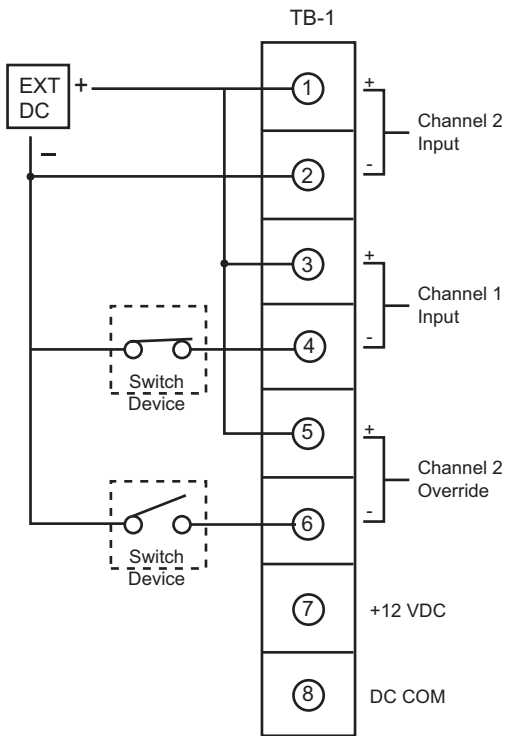

Sinking Type Device With External
 DC Power Source
 Two Wire Input (maintained)

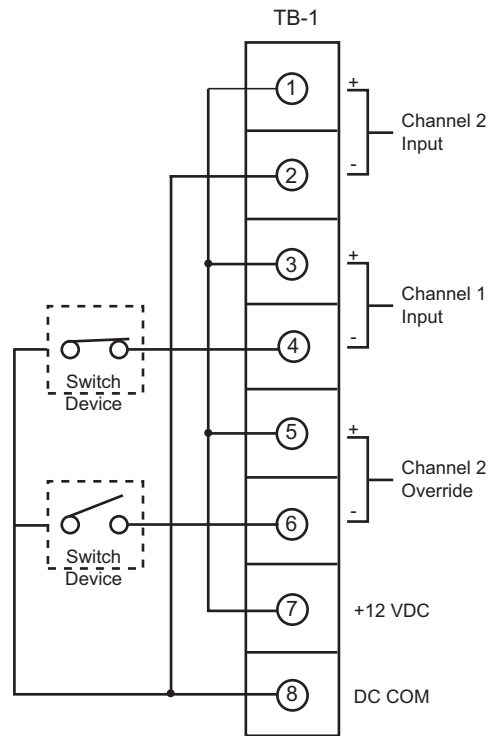

Sinking Type Device Using
 Internal DC Power Supply
 Two Wire Input (maintained)

Figure 10

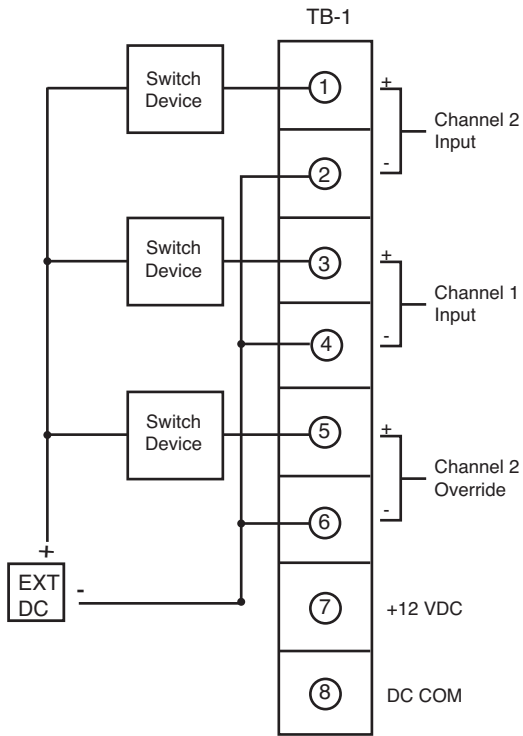

Sourcing Type Device With External DC Power Source
 Three Wire Input (Momentary)

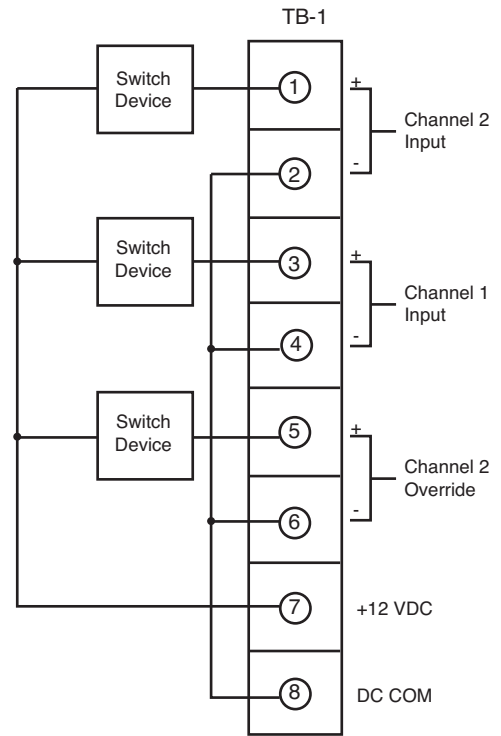

Sourcing Type Device Using Internal DC Power Supply
 Three Wire Input (Momentary)

Figure 11

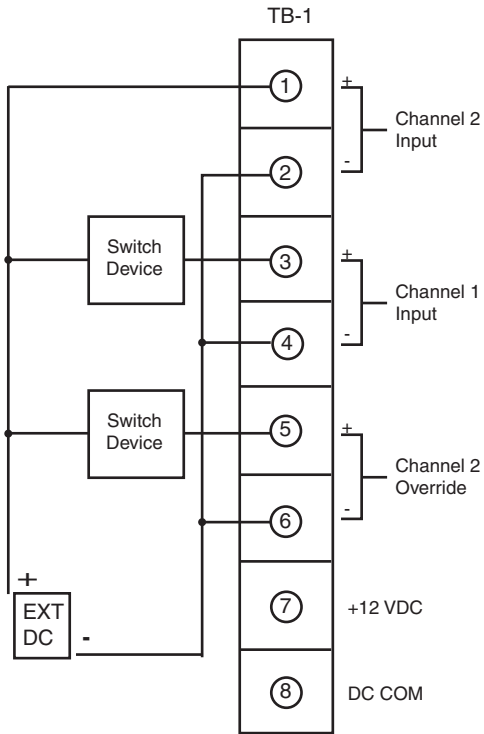

Sourcing Type Device With External DC Power Source
 Two Wire Input (maintained)

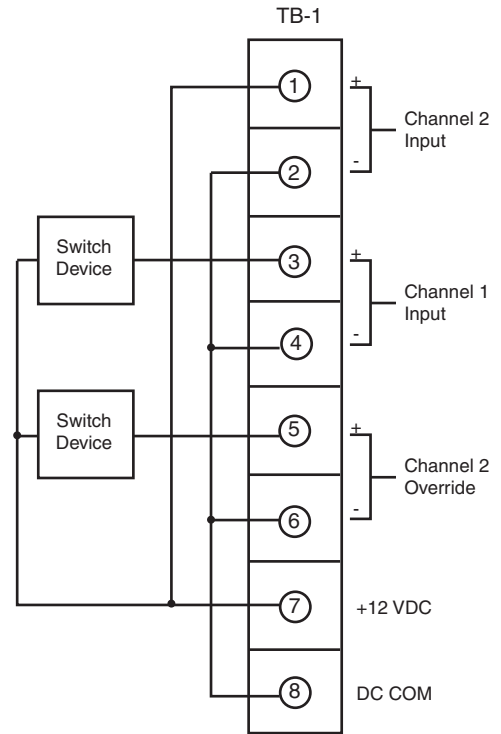

Sourcing Type Device Using Internal DC Power Supply
 Two Wire Input (maintained)

Figure 12

Alternate/Simultaneous Operation – Three Wire Mode, Sinking Type Input Devices

- 1. Refer to Figures 13a through 16a for various switching devices which can be used.
- 2. Jumper the positive (+) inputs of the opto-coupler Terminal Block TB-1, Terminal 1, 3, and 5 together. Tighten terminals 1 and 3 securely.
- 3. Connect a DC power source, positive voltage to Terminal 5.
 - a. Positive (+) DC if external power supply is used. Tighten Terminal 5 securely.
 - b. Jumper from Terminal Block TB-1 Terminal 7 if internal DC supply is used.

Tighten both Terminals 5 and 7 securely.
- 4. Connect output side of the switching circuit (start) to the channel 2 input negative side (-) of the opto-coupler at Terminal Block TB-1, Terminal 2.
 - a. Momentary switch contact (normally open)
 - b. Normally open contact of form “C” Relay
 - c. Open collector output of NPN Transistor for solid-state sensors
 - d. Collector of NPN output module for PLC interface or computer card

Tighten Terminal 2 of Terminal Block TB-1 securely.

NOTE: With the exception of the relay contact in 4b above, all other outputs or switches must be momentary in nature.
- 5. Connect the input side of the switching circuits if momentary switches or relay contact is used to the negative side (-) of the power source.
 - a. External negative (-) if external DC power source is used.

- b. Negative (-) or DC common of the internal voltage source, Terminal 8 of TB-1.
- 6. Connect the output side of the switching circuit (stop) to the Channel 1 input negative side (-) of the opto-coupler at Terminal Block TB-1, Terminal 4.
 - a. Momentary switch contact (normally open)
 - b. Normally closed relay contact of form “c” relay
 - c. Open collector output of NPN Transistor for solid-state sensors
 - d. Collector of NPN Output Module for PLC interface or computer card

Tighten Terminal 4 of Terminal Block TB-1 securely.

NOTE: With the exception of the relay contact in 6b above, all other outputs or switches must be momentary in nature.
- 7. Connect the input side of the switching circuits of momentary switch or relay contact if used to the negative side (-) of the power source.
 - a. External negative (-) if external DC power source is used.

or,

- b. Negative (-) or DC common of the internal voltage source, Terminal 8 of TB-1.
- 8. For external sensors or when using PLC output modules or computer cards, connect power to sensors or cards accordingly.
 - a. External power source, positive (+) and negative (-) to sensor power leads

or,

- b. Internal power source, positive (+) Terminal 7, TB-1 and negative (-) Terminal 8, TB-1 to sensor power leads. Tighten Terminals 7 & 8 securely.

9. Optional Channel 2 Override Input Wiring

NOTE: If using the Channel 2 override input (start override) the switching circuit must be a maintained type so that Channel 1 or Channel 2 input switching will have no effect on input switching.

a. Connect the output side of the switching circuit to the Channel 2 override input negative side (-) of the opto-coupler at Terminal 6 of Terminal Block TB-1.

- 1. Maintained switch, normally open contact
- 2. Normally open relay contact
- 3. Open collector output of NPN Transistor in PLC output module or computer card.

Tighten Terminal 6 of Terminal Block TB-1.

b. Connect the input side of the Channel 2 override switch to negative side (-) of the power source.

1. External negative (-) of external DC power source if used.

2. Negative (-) or DC common of the internal voltage source, Terminal 8 of Terminal Block TB-1.

10. Double check all input wiring and switching circuit hook-up and connection to insure proper wiring and connections. Refer to figures 13a through 16a.

11. Make sure all Terminal Block connections on TB-1 are securely tightened at this time.

12. Double check any external sensor power wiring and connections. Refer to the appropriate sensor data sheets for confirmation.

13. This completes the input switching circuit wiring. Make sure all debris, insulation chips or wire fragments are cleaned up and control circuit boards blown off with dry air before proceeding.

14. Proceed to the start up section of the manual for start up and check out.

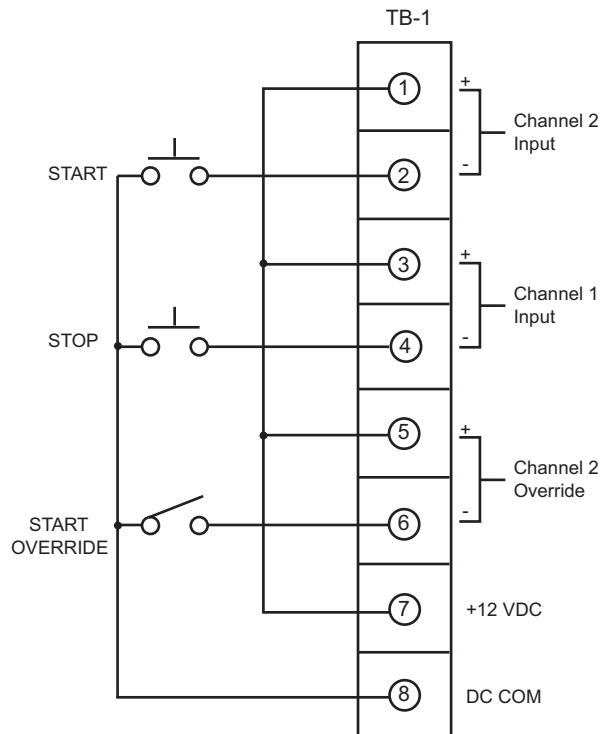

Figure 13a

Alternate Mode Operation (Single)

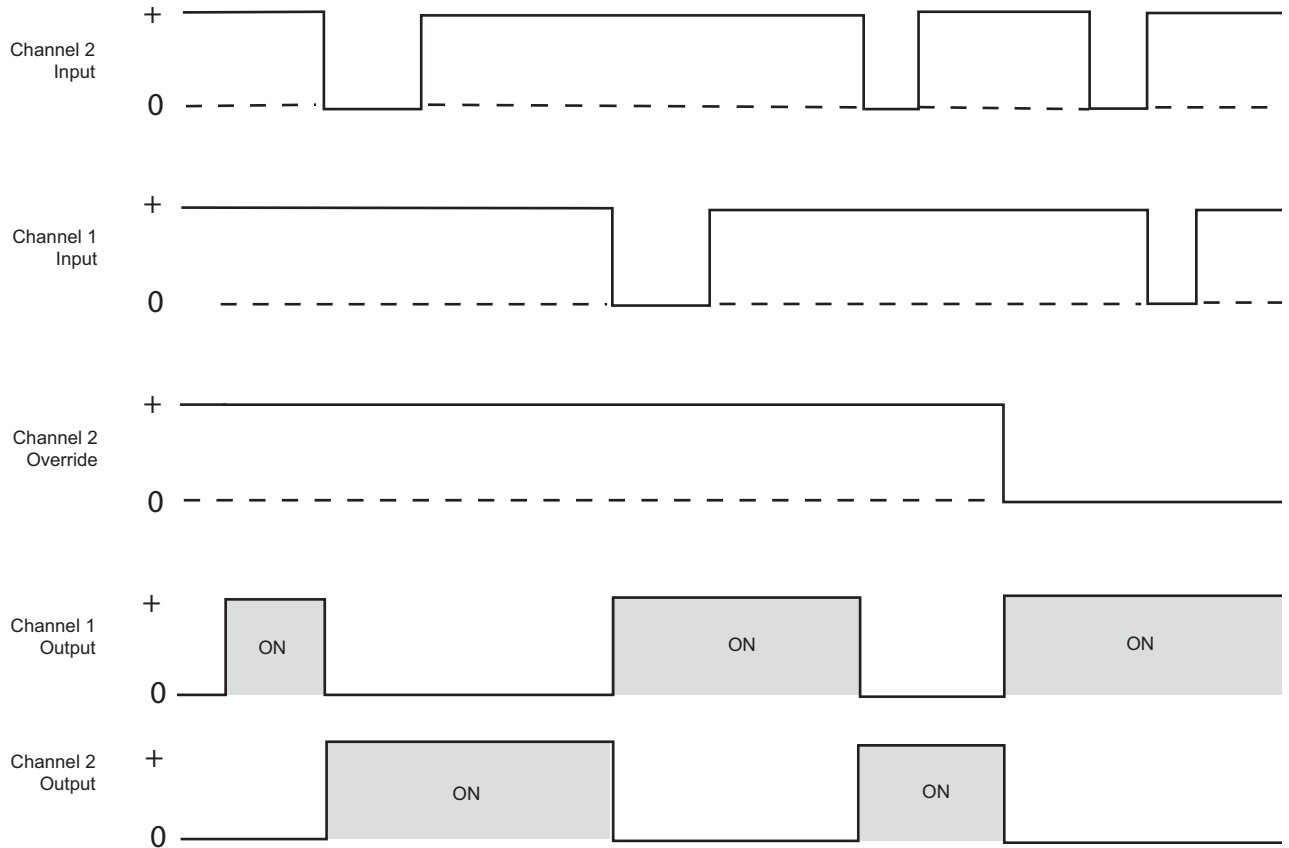

Figure 13b

Simultaneous Mode Operation (Dual)

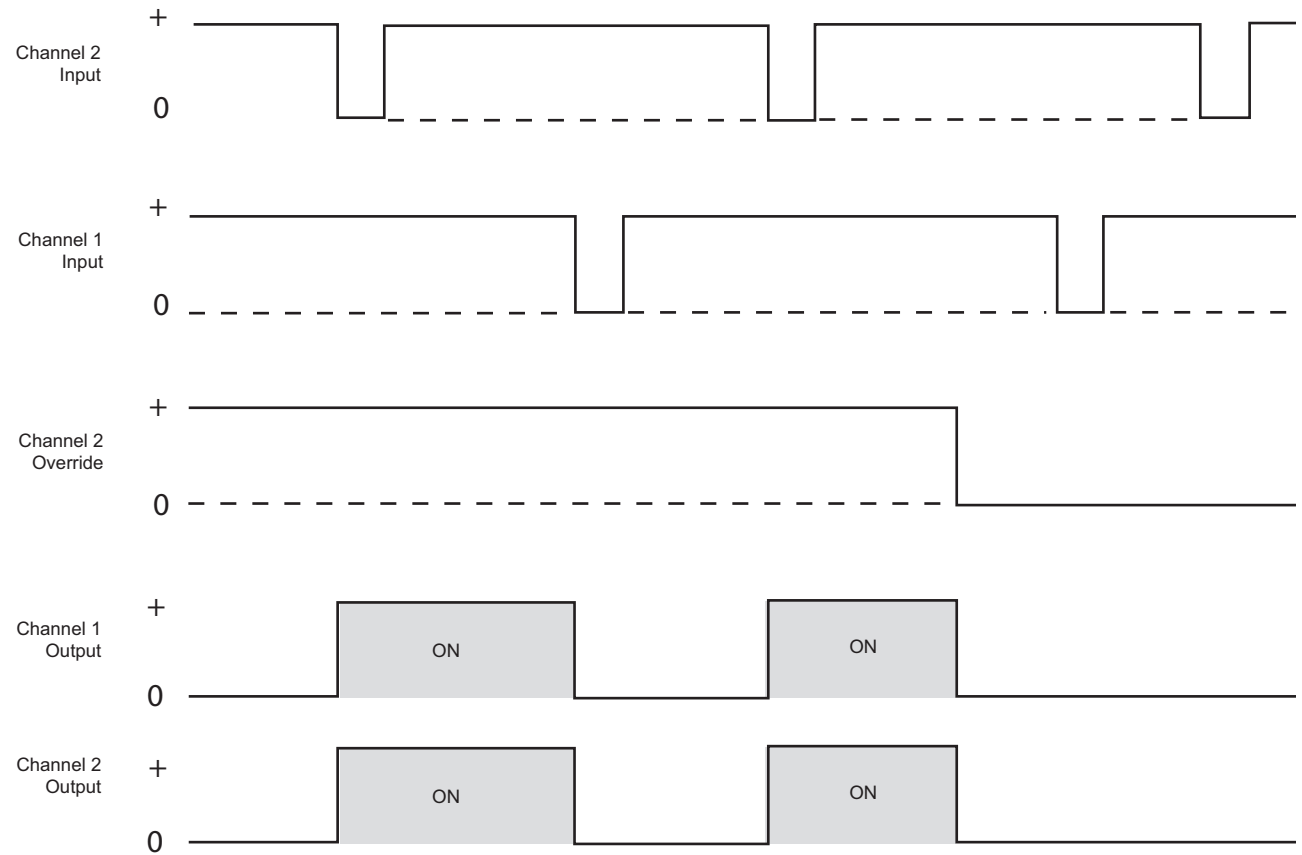

Figure 13c

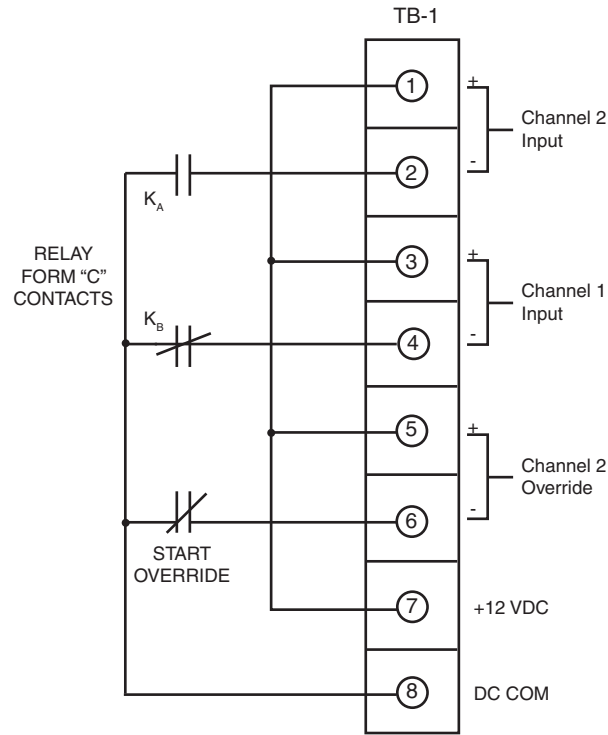

Figure 14a

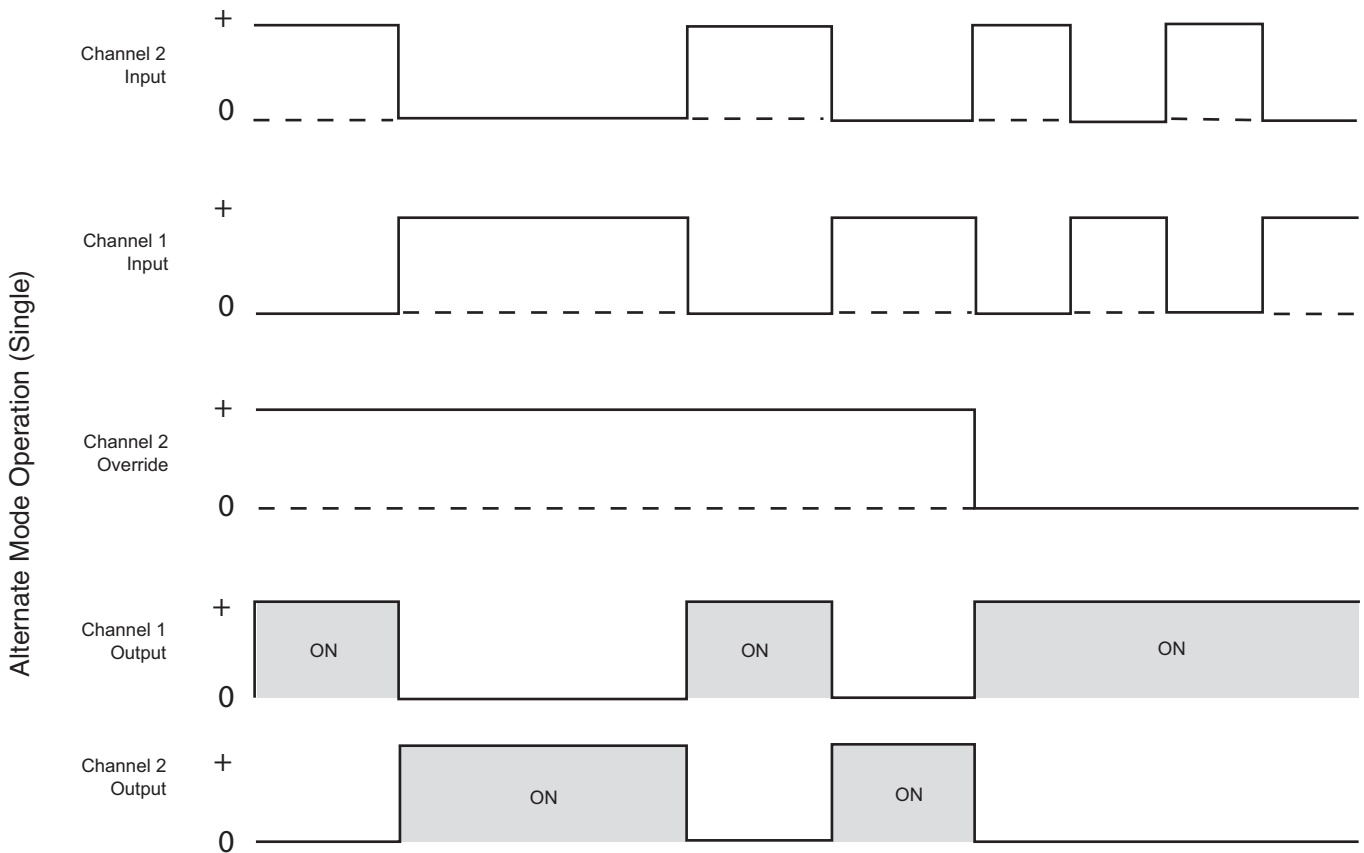

Figure 14b

Simultaneous Mode Operation

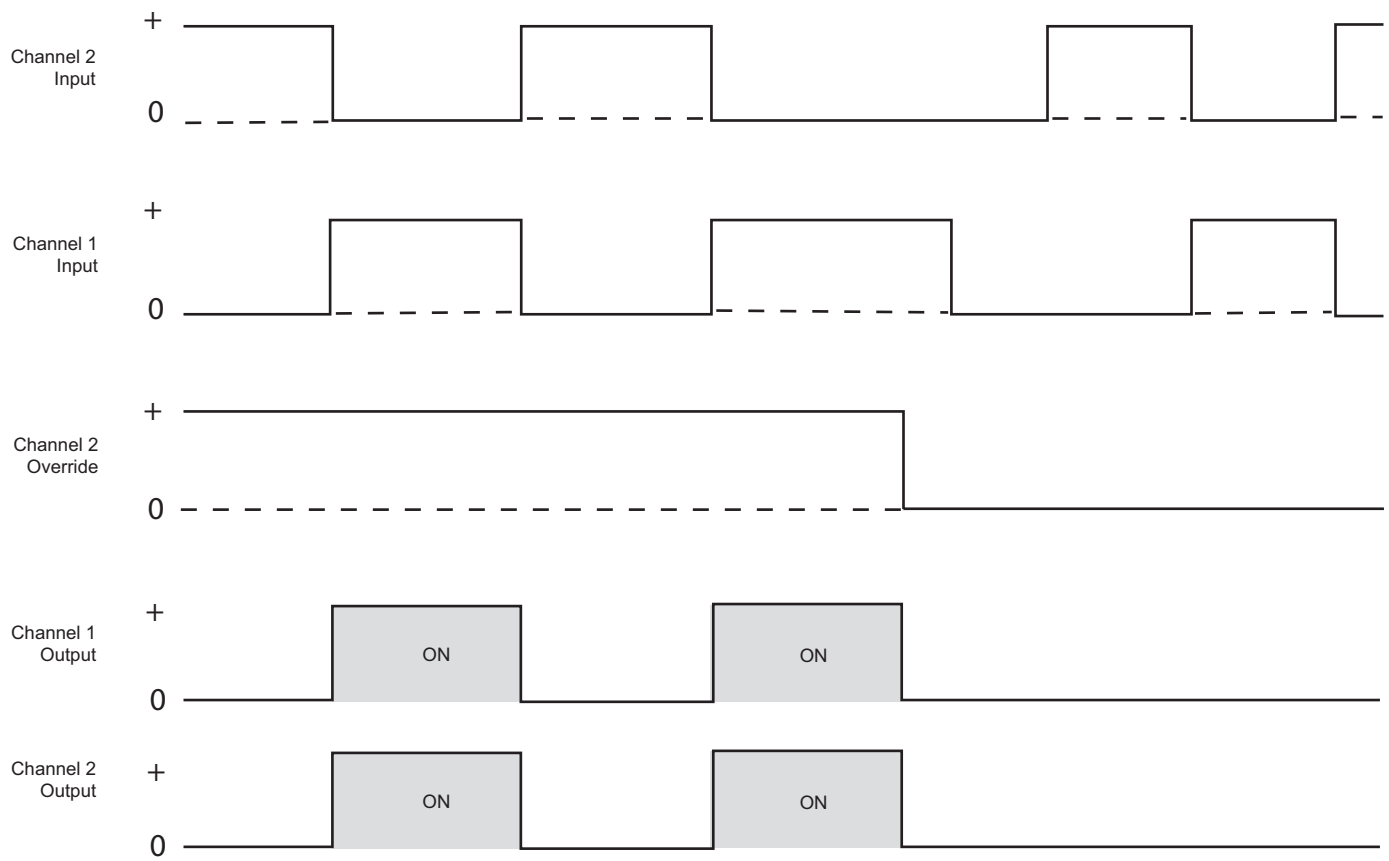

Figure 14c

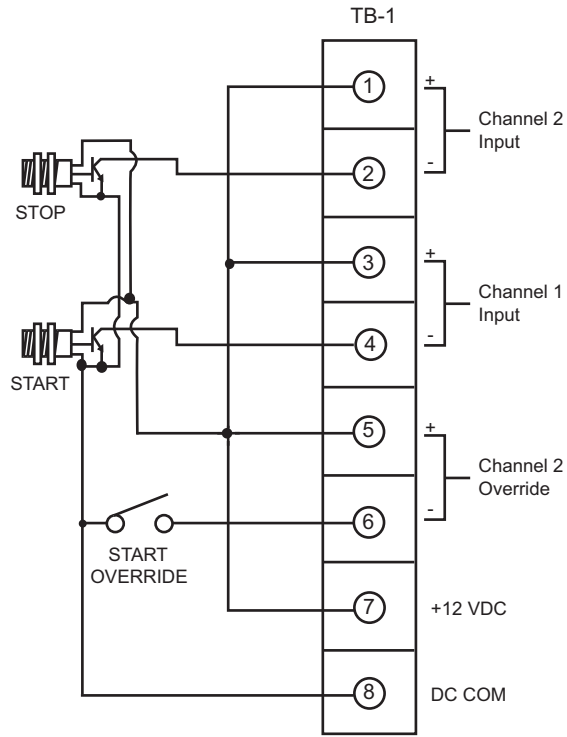

Figure 15a

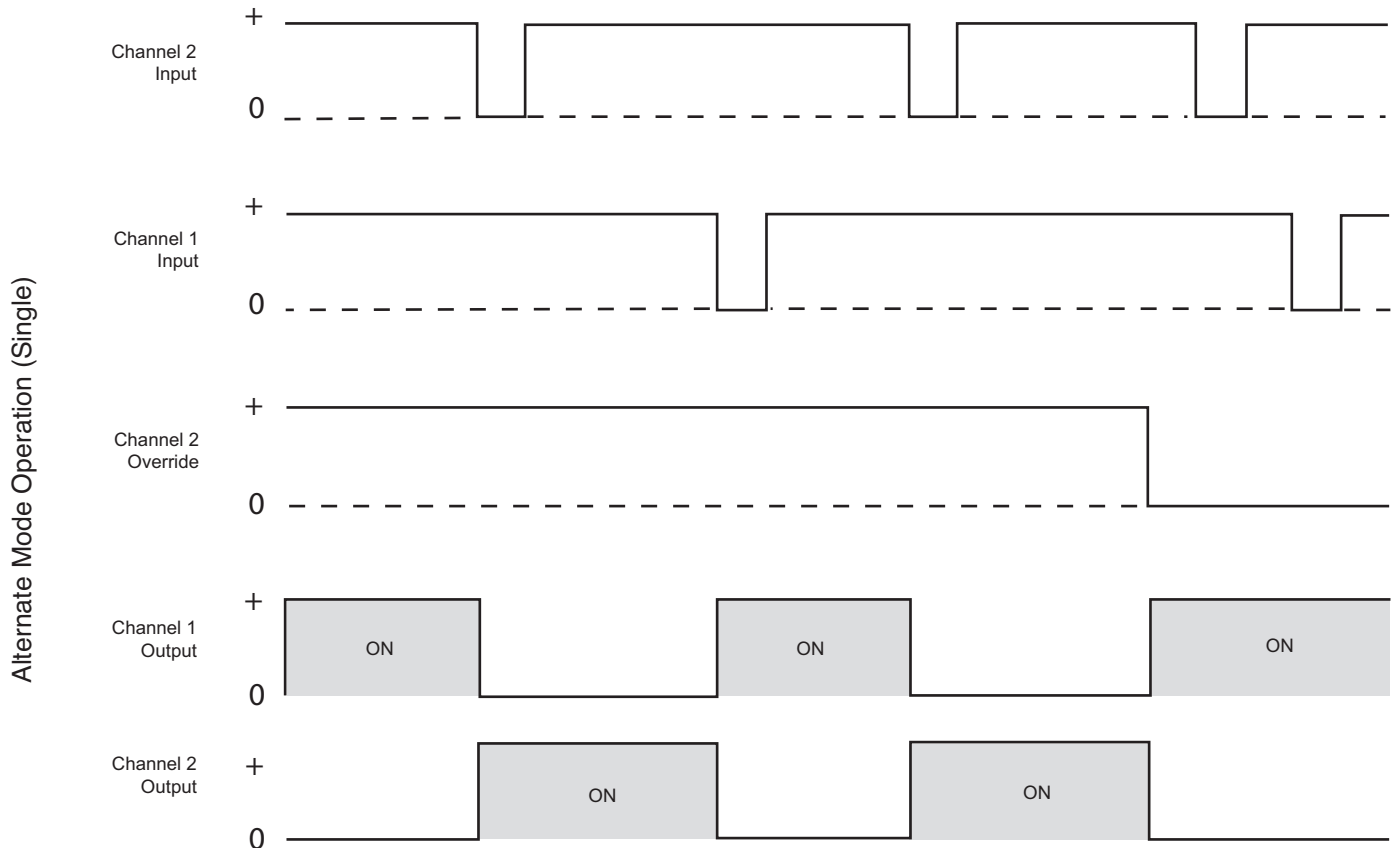

Figure 15b

Simultaneous Mode Operation

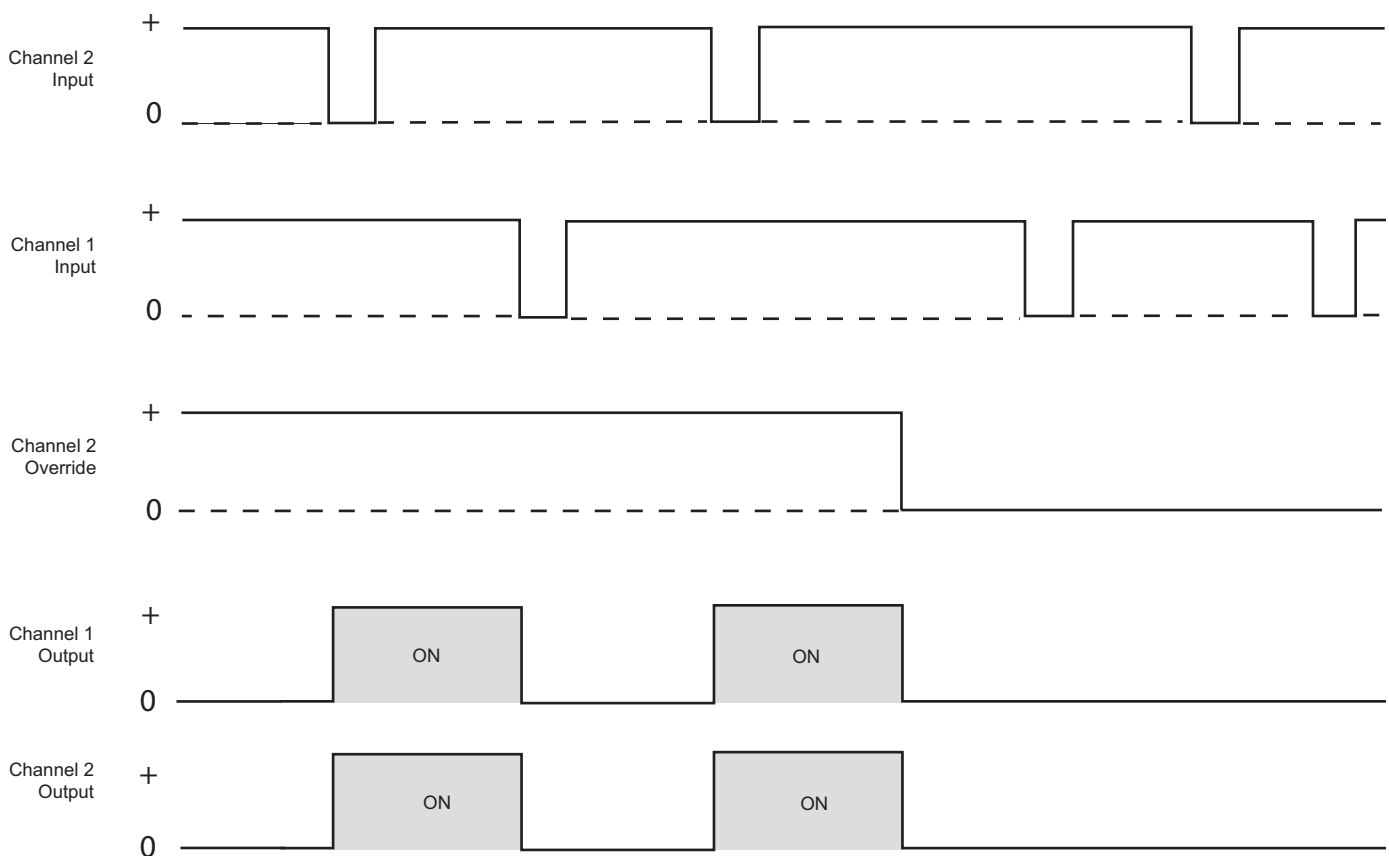

Figure 15c

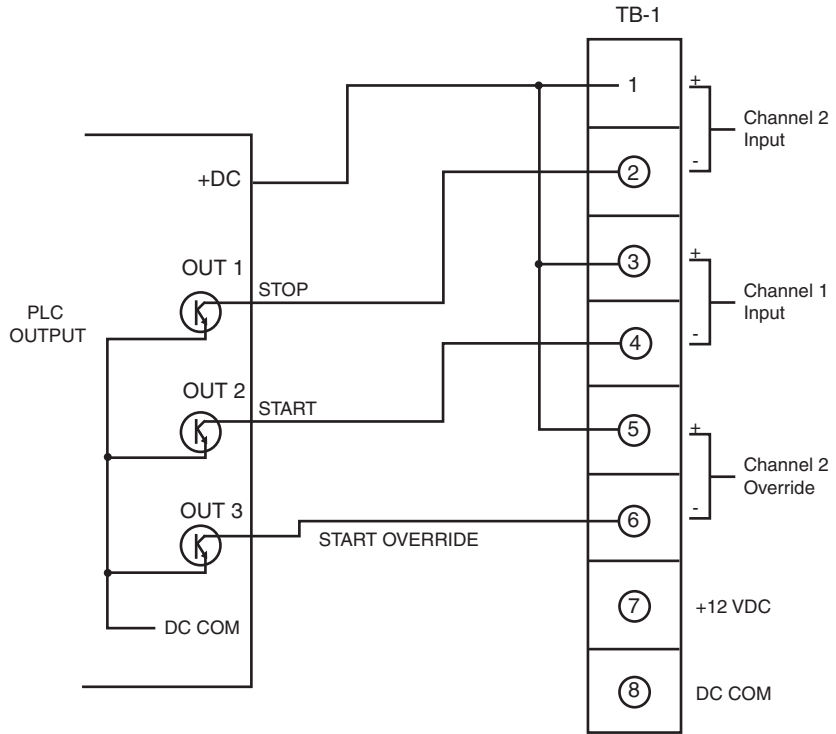

Figure 16a

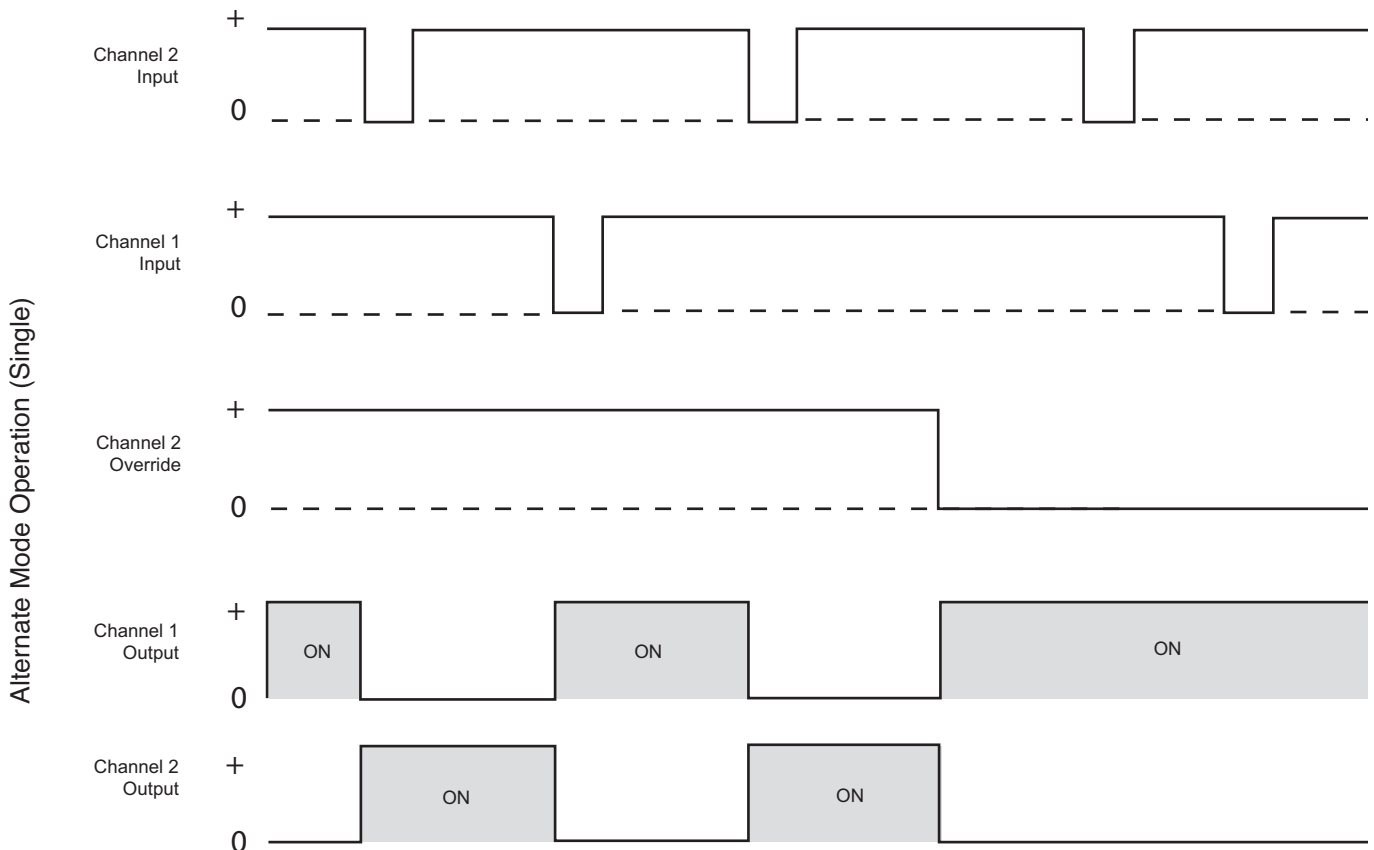

Figure 16b

Simultaneous Operation (Dual)

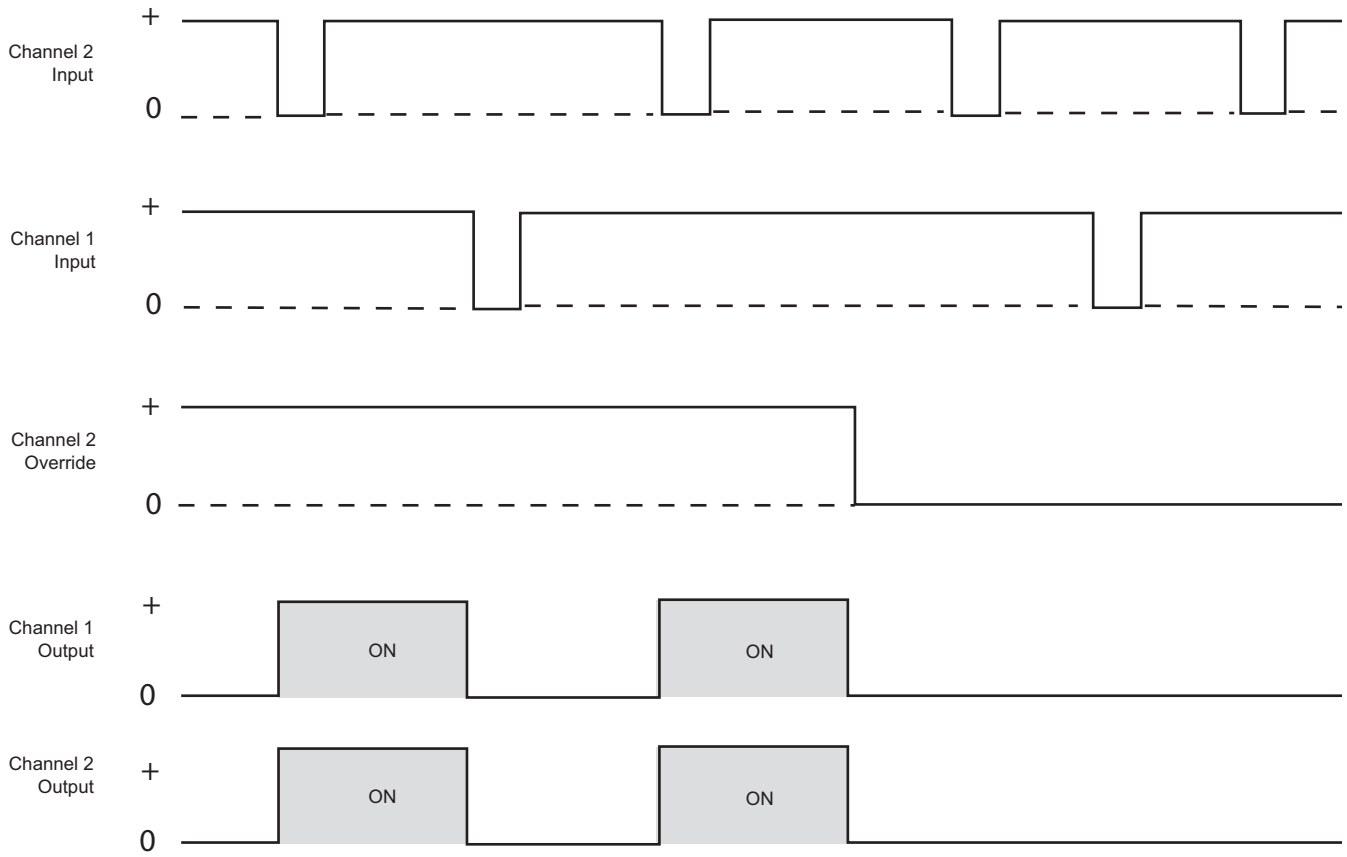

Figure 16c

Alternate/Simultaneous Operation – Two Wire Mode, Sinking Type Input Devices

- 1. Refer to Figures 17a through 20a for various switching devices which can be used.
- 2. Jumper the positive (+) inputs of the opto-coupler Terminal Block TB-1, Terminals 1, 3, and 5 together. Tighten Terminals 1 and 3 securely.
- 3. Connect a DC power source, positive (+) voltage to Terminal 5, TB-1.
 - a. Positive (+) DC if external power supply is used or, Tighten Terminal 5 securely.
 - or,
 - b. Jumper from Terminal 7 of Terminal Block TB-1 to Terminal 5 if internal voltage source is used. Tighten both Terminals 5 and 7 of Terminal Block TB-1 securely.
- 4. Connect a DC power source, negative (-) voltage to Terminal 2, TB-1.
 - a. Negative (-) DC of external power supply used. Tighten Terminal 2 securely.
 - b. Jumper from Terminal 8 of Terminal Block TB-1 to Terminal 2 of TB-1 if internal voltage source is used. Tighten Terminal 2 only at this time.
- 5. Connect the output side of the switching circuit to the Channel 1 input negative side (-) of the opto-coupler at Terminal Block TB-1, Terminal 4.
 - a. Normally closed contact of mechanical switch
 - b. Normally closed contact of relay contact
 - c. Open collector output of NPN Transistor (normally on) for solid-state sensors
 - d. Collector output of NPN Transistor (normally on) for PLC interface or computer card

Tighten Terminal 4 of Terminal Block TB-1 securely.

NOTE: For operation of the CBC-400/CBC-450 to power up with Channel 1 output “on” in alternate mode or both outputs “off” in simultaneous mode, the Channel 1 input switch must be maintained closed for mechanical switches or “on” in the case of solid-state switches.

- 6. Connect the input side of the switching circuit when mechanical switches are used to the negative side (-) of the DC power source.
 - a. External negative (-) of external DC power source
 - or,
 - b. Negative (-) or DC common of the internal DC power source, Terminal 8 of Terminal Block TB-1 securely.
- 7. For external sensors or when using PLC output modules or computer cards, connect power source to sensors or cards accordingly.
 - a. External power source, positive (+) and negative (-) to appropriate leads on terminals
 - or,
 - b. Internal power source, positive (+) Terminal 7, TB-1 and negative (-) Terminal 8, TB-1 to appropriate sensor leads of terminals. Tighten Terminals 7 and 8 securely.
- 8. Optional Channel 2 Override Input Wiring

NOTE: If using the Channel 2 override input (start override) the switching circuit must be a maintained type so that Channel 1 input switching will have no effect on the output when maintained.

 - a. Connect the output side of the switching circuit to the Channel 2 override input negative side (-) of the opto-coupler at Terminal 6 of Terminal Block TB-1.
 - 1. Maintained switch, normally open contact
 - 2. Normally open relay contact

- 3. Open collector output of NPN Transistor in PLC output module or computer card.

Tighten Terminal 6 of Terminal Block TB-1 securely at this time.
- b. Connect the input side of the Channel 2 override switch to negative side (-) of the DC power source.
- 1. External negative (-) of external DC power source if used.
- or,
- 2. Negative (-) or DC common of the internal voltage source at Terminal 8 of Terminal Block TB-1. Tighten Terminal 8 securely at this time.
- 9. Double check all input wiring and switching circuit connection to insure proper wiring and hook-up. Refer to figures 17a through 20a.
- 10. Make sure all Terminal Block connections on Terminal Block TB-1 are securely tightened at this time.
- 11. Double check any external sensor power wiring and connections. Refer to the appropriate sensor data sheets for connections.
- 12. This completes the input switching circuit wiring. Make sure all debris, insulation chips or wire fragments are cleaned up and control circuit boards blown off with dry air before proceeding.
- 13. Proceed to the start-up section of the manual for start up and check out.

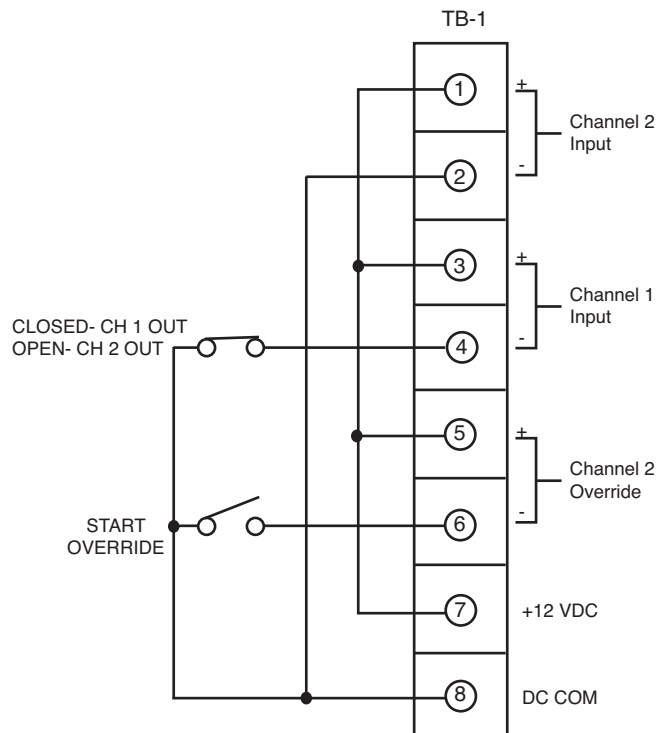

Figure 17a

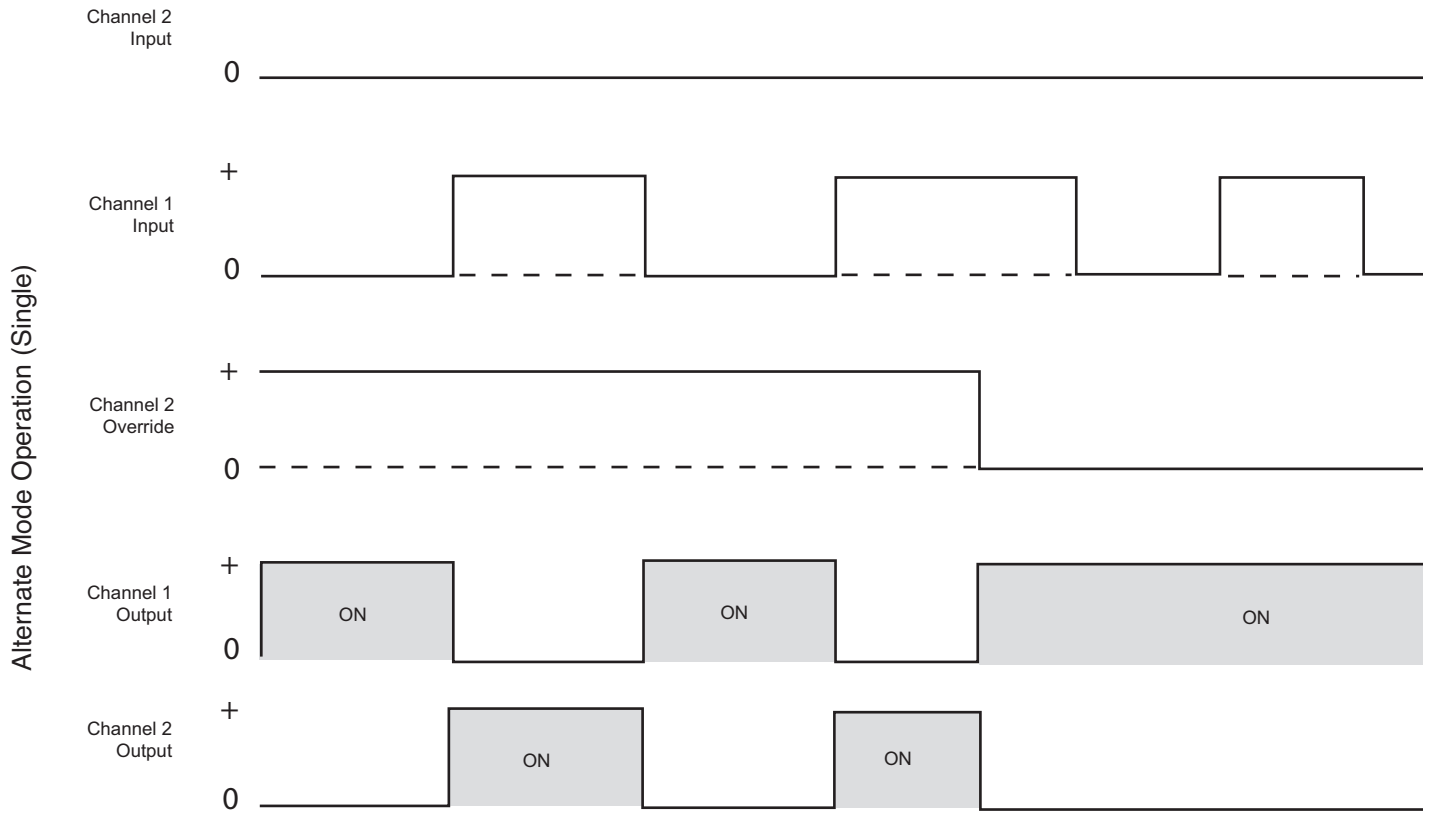

Figure 17b

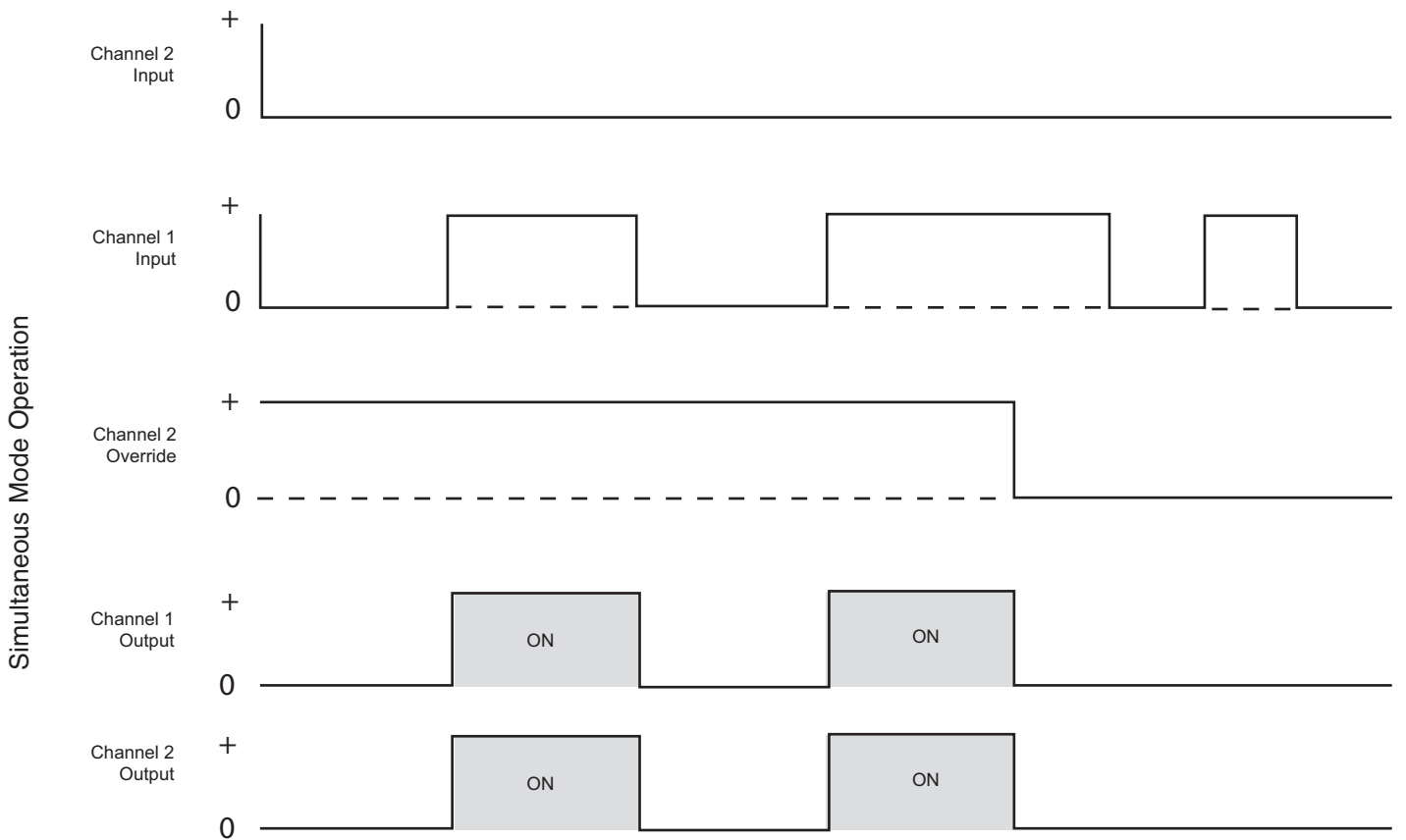

Figure 17c

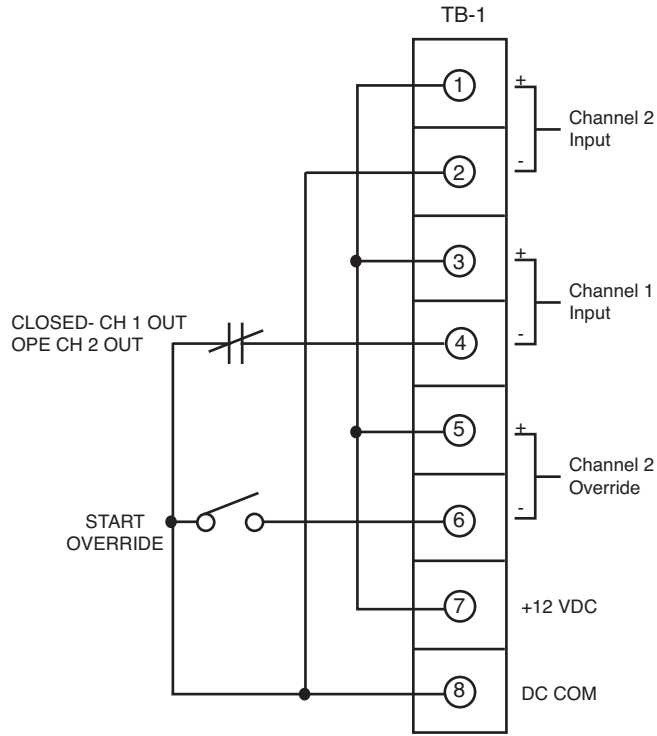

Figure 18a

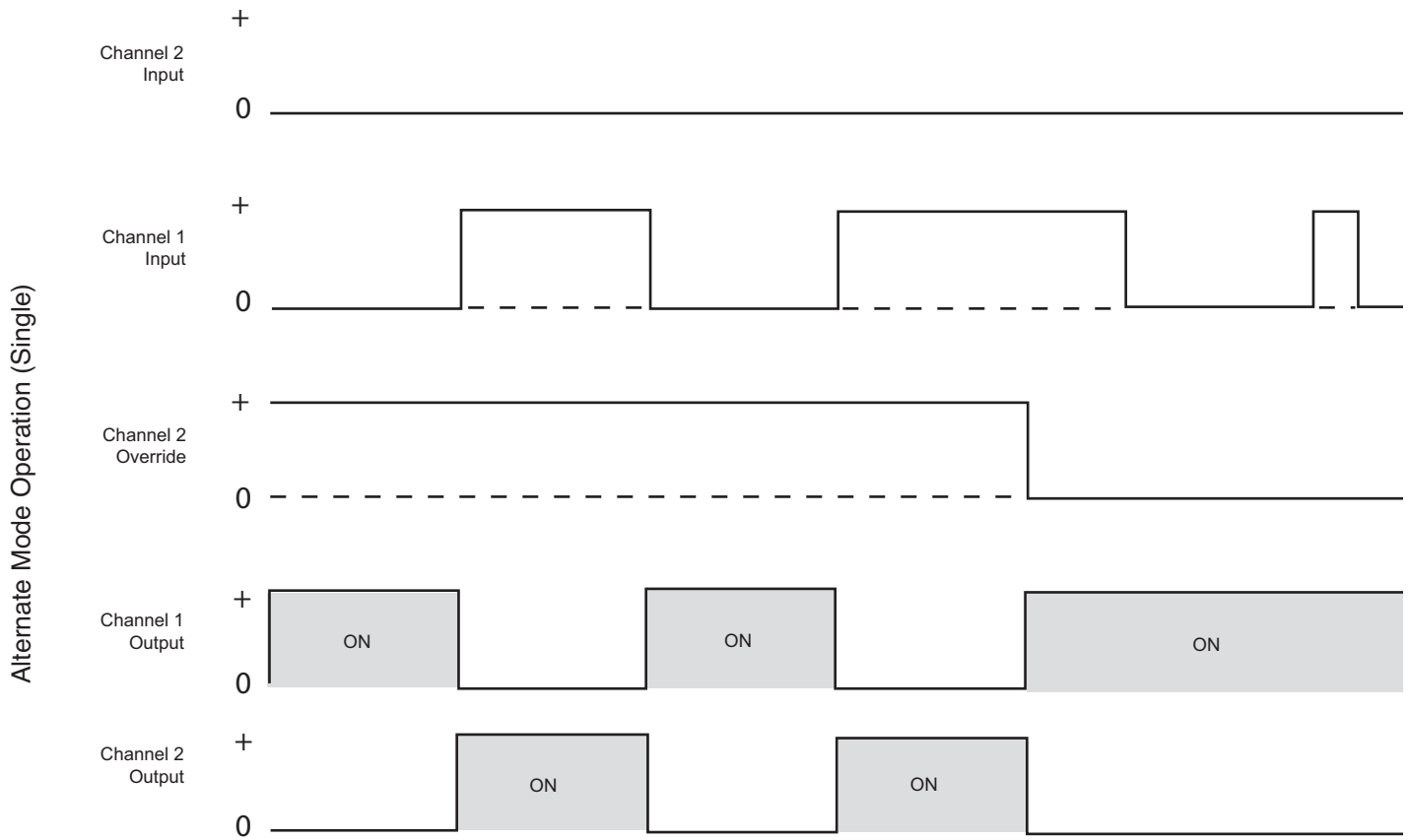

Figure 18b

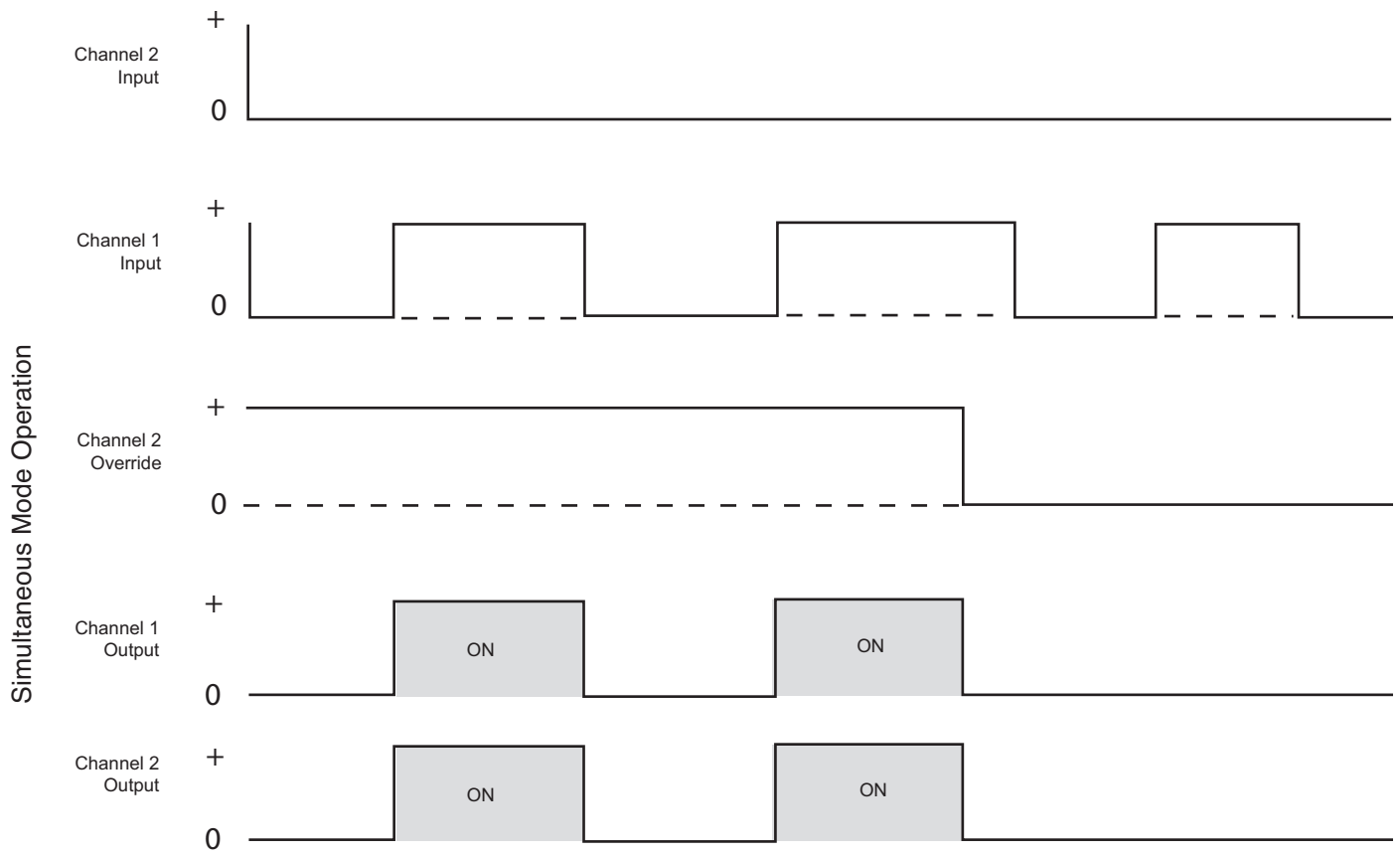

Figure 18c

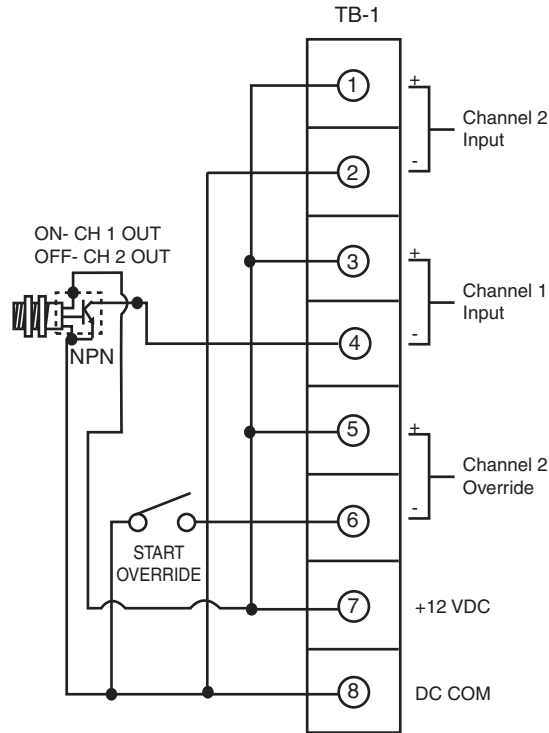

Figure 19a

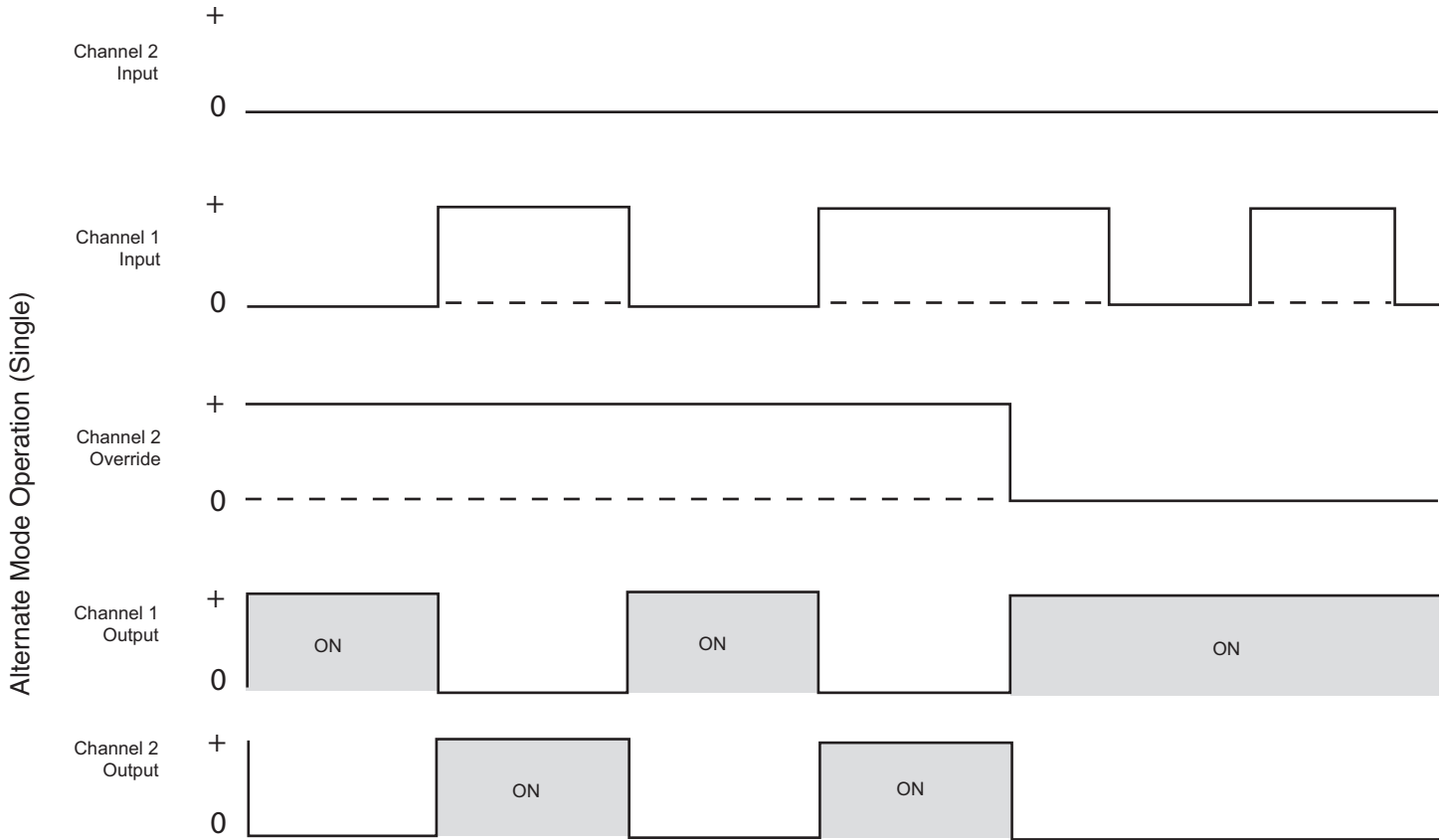

Figure 19b

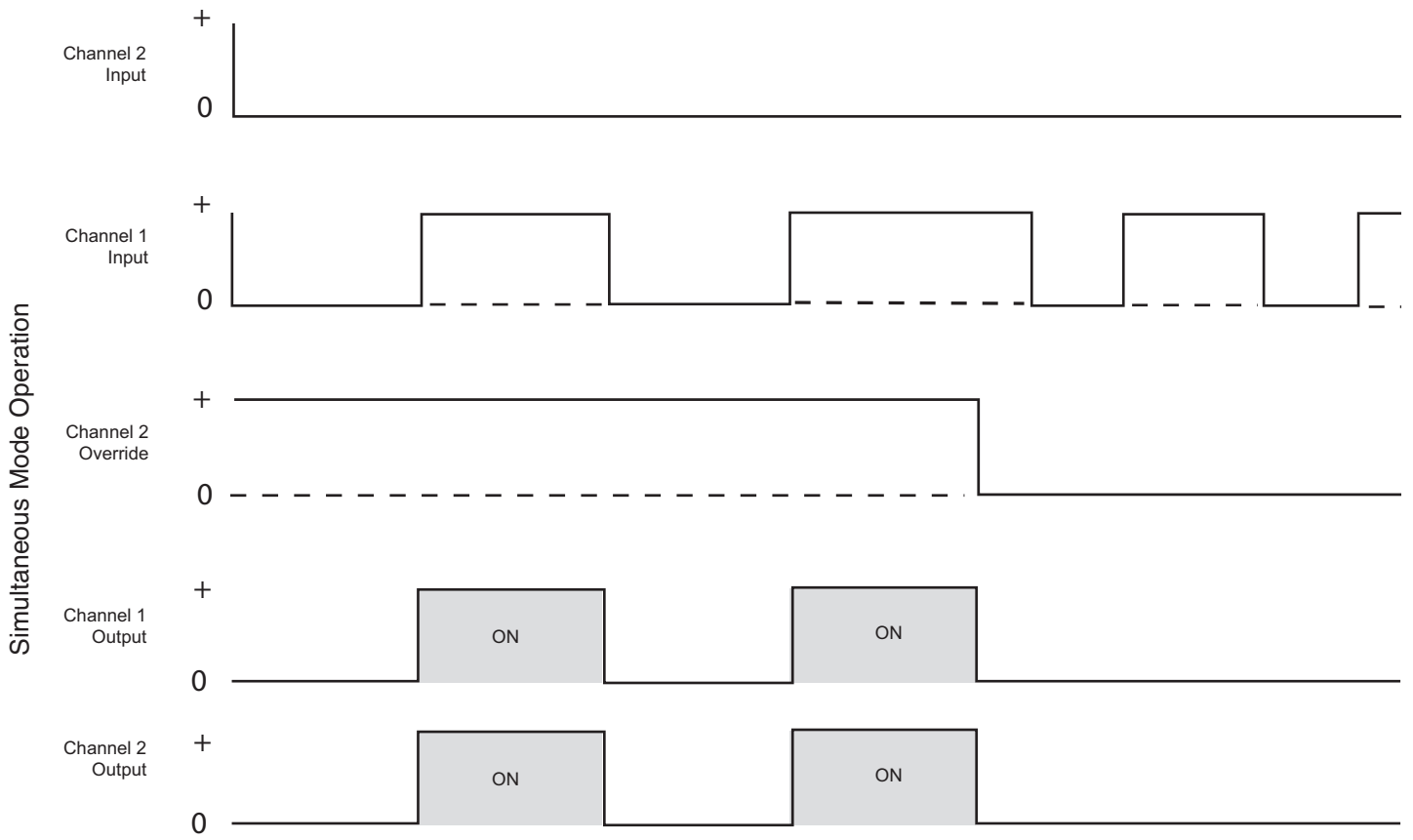

Figure 19c

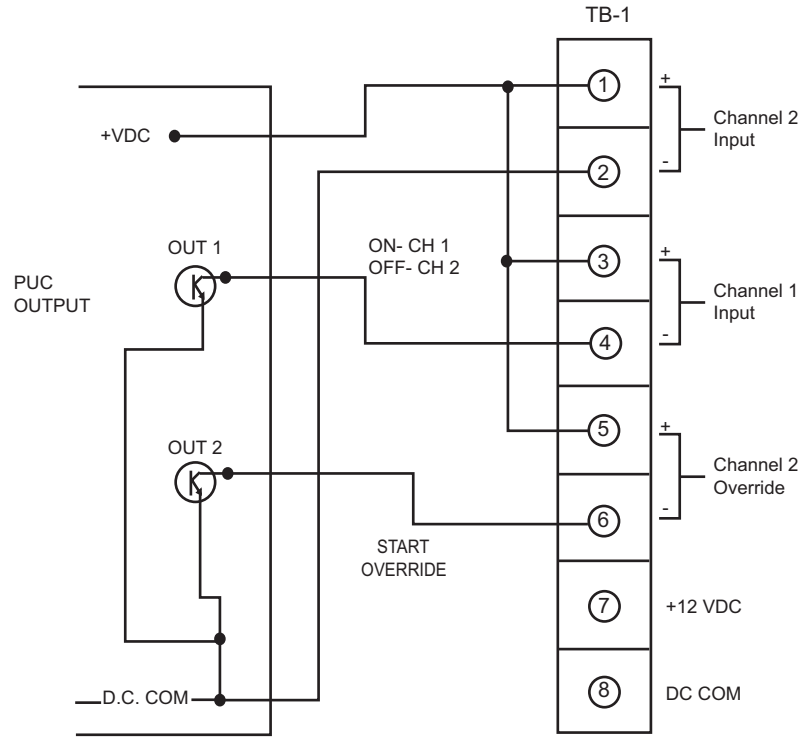

Figure 20a

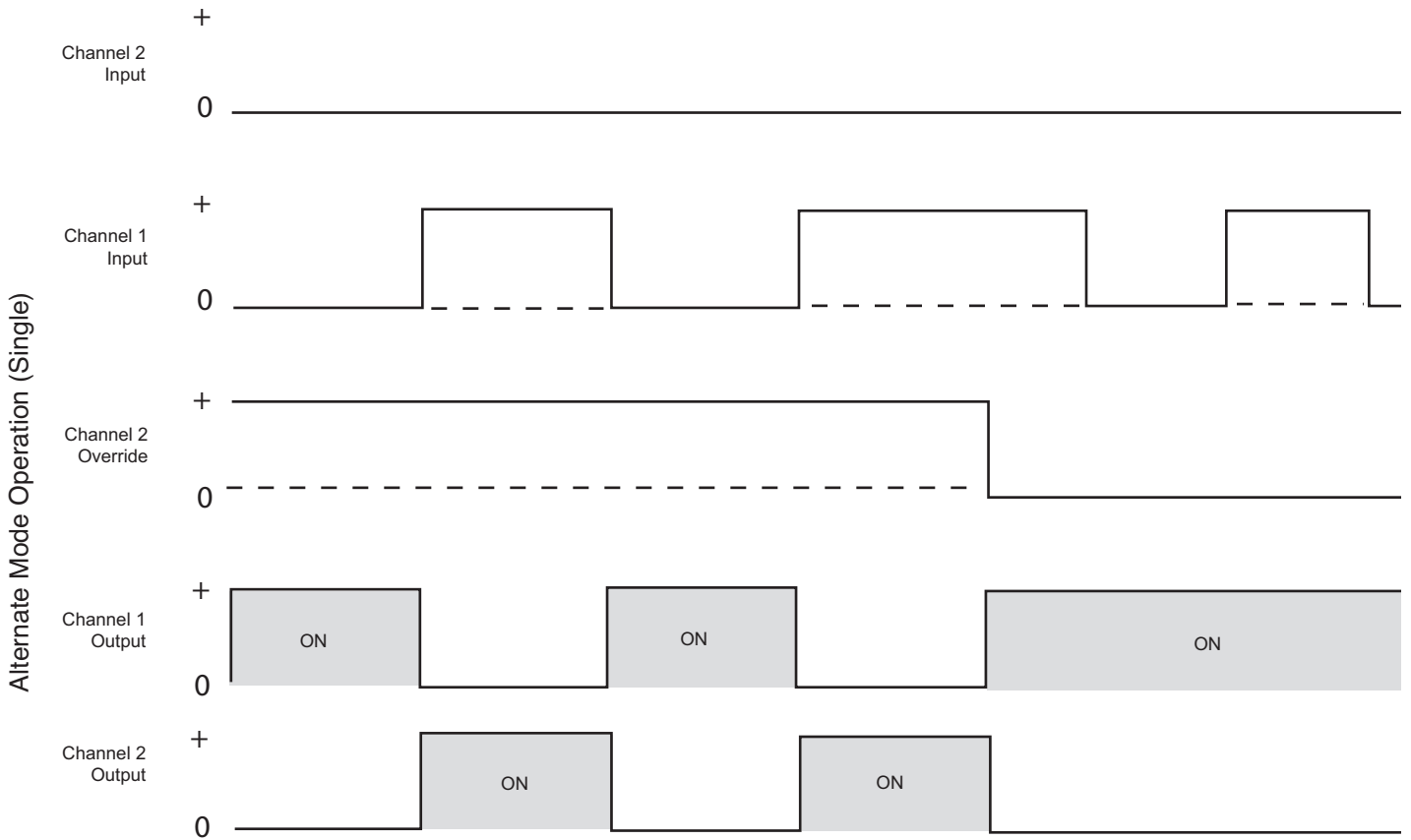

Figure 20b

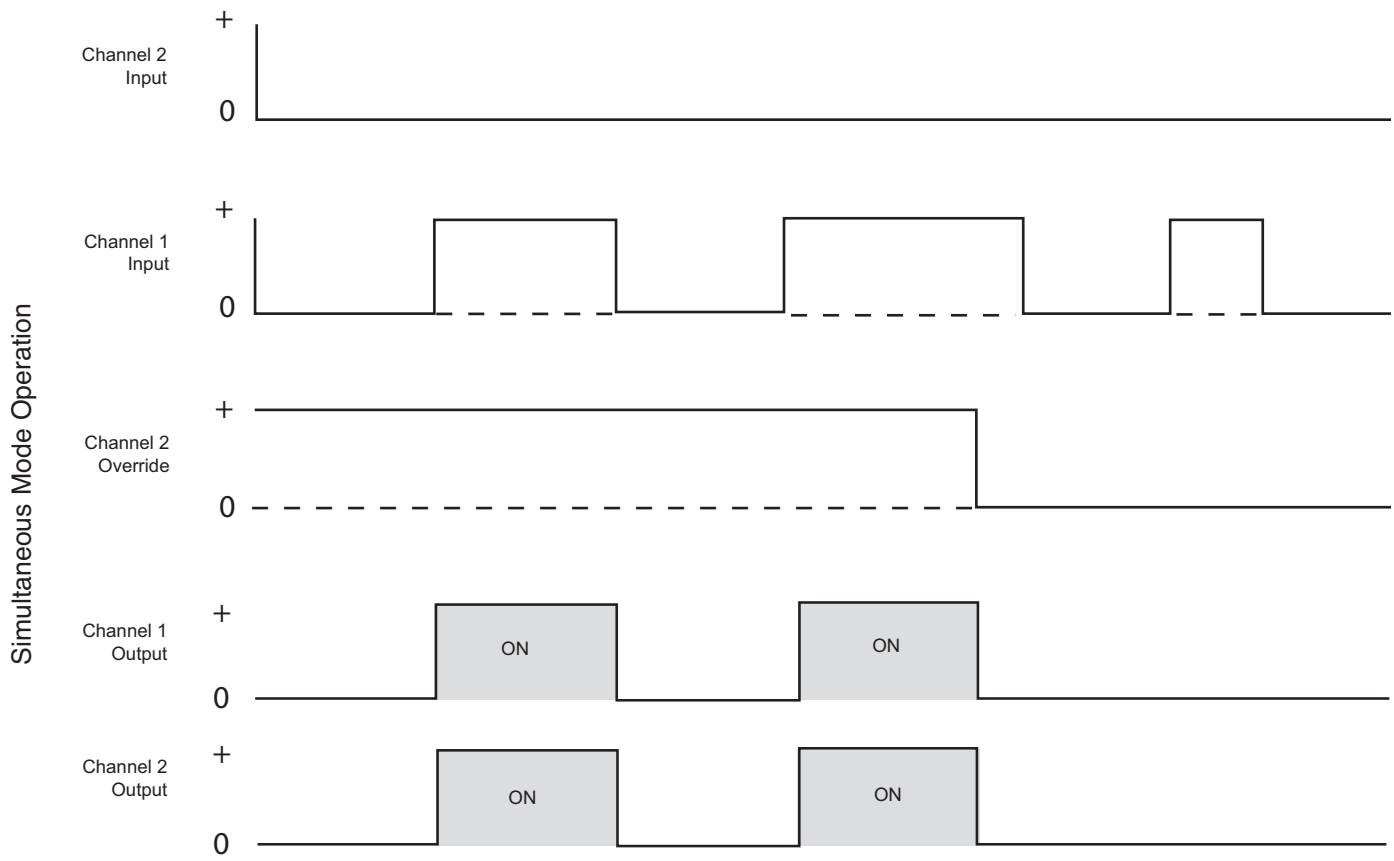

Figure 20c

Alternate/Simultaneous Operation – Three Wire Mode, Sourcing Type Input Devices

- 1. Refer to Figures 21a through 24a for various switching devices which can be used.
- 2. Jumper the negative (-) inputs of the opto-coupler Terminal Block TB-1, Terminals 2, 4, and 6 together. Tighten Terminals 2 and 4 securely at this time. Snug Terminal 6 only.
- 3. Connect a DC power source, negative voltage or DC Common to Terminal 6 of Terminal Block TB-1.
 - a. Negative (-) DC or DC common of external power supply is used. Tighten Terminal 6 of Terminal Block TB-1.

or,
 - b. DC Common negative (-) of internal voltage source terminal 8 of Terminal Block TB-1 to Terminal 6 of TB-1. Tighten both Terminals 6 and 8 of TB-1 at this time.
- 4. Connect the output side of the switching circuit being used to the Channel 2 input (start) positive side (+) of the opto-coupler at Terminal 1 of Terminal Block TB-1.
 - a. Momentary switch contact (normally open)
 - b. Normally open contact of form “C” Relay
 - c. Open collector output of PNP Transistor from solid-state sensors
 - d. Collector of PNP output module from a PLC interface or computer card.

Tighten Terminal 1 of Terminal Block TB-1 securely.

NOTE: With the exception of the relay contact in 4b above, all other outputs or switches must be momentary in nature.

- 5. Connect the input side of the switching circuits if momentary switches or relay contact was used to the positive side (+) of the DC power source.
 - a. External positive (+) if external DC power source is used.

or,
 - b. Positive side (+) of the internal DC power supply, Terminal 7 of Terminal Block TB-1.
- 6. Connect the output side of the switching circuit (stop) being used to the Channel 1 input positive side (+) of the opto-coupler at Terminal 3 of Terminal Block TB-1.
 - a. Momentary switch contact (normally open)
 - b. Normally closed relay contact of form “c” relay
 - c. Open collector output of PNP Transistor for solid-state sensors
 - d. Collector of PNP Output Module for PLC interface or computer card

Tighten Terminal 3 of Terminal Block TB-1 securely.

NOTE: With the exception of the relay contact in 6b above, all other outputs or switches must be momentary in nature.

- 7. Connect the input side of the switching circuit of momentary switches or relay contact if used to the positive side (+) of the DC power source.
 - a. External positive (+) of external DC voltage source is used.

or,
 - b. Positive side (+) of the internal DC voltage source at Terminal 7 of Terminal Block TB-1.

8. For external sensors or when using PLC output modules or computer cards, connect power to sensors or cards accordingly.

a. External DC power source, positive (+) and negative (-) to sensor or card power leads per appropriate installation instructions.

or,

b. Internal DC power source, positive (+) Terminal 7 of Terminal Block TB-1 and negative (-) or DC Common Terminal 8 of Terminal Block TB-1. Make sure terminals are snugged.

9. Optional Channel 2 Override Input Switching

NOTE: If using the Channel 2 override input (start override) the switching circuit must be a maintained type so that Channel 1 and Channel 2 input switching will have no effect on output switching.

a. Connect the output side of the switching circuit to the Channel 2 override input positive side (+) of the opto-coupler at Terminal 5 of Terminal Block TB-1.

1. Maintained switch, normally open contact

2. Normally open relay contact

3. Open collector output of PNP Transistor from PLC output module or computer card.

Tighten Terminal 5 of Terminal Block TB-1.

b. Connect the input side of the Channel 2 override switch to positive side (+) of the power source.

1. External DC positive (+) of the external DC power source.

or,

2. Positive (+) of the internal DC voltage source, Terminal 7 of Terminal Block TB-1.

10. Double check all input switching circuit wiring and hook-ups to insure proper wiring and connections. Refer to figures 21a through 24a.

11. Make sure all terminal block connections on TB-1 are securely tightened at this time.

12. Double check any external wiring connections for hook-up and connections. Refer to the appropriate data sheets for confirmation.

13. This completes the input switching and wiring connections. Make sure all debris, insulation chips or wire fragments are cleaned up and control circuit boards blown off with dry air before proceeding.

14. Proceed to the start up section of the manual for start up and check out.

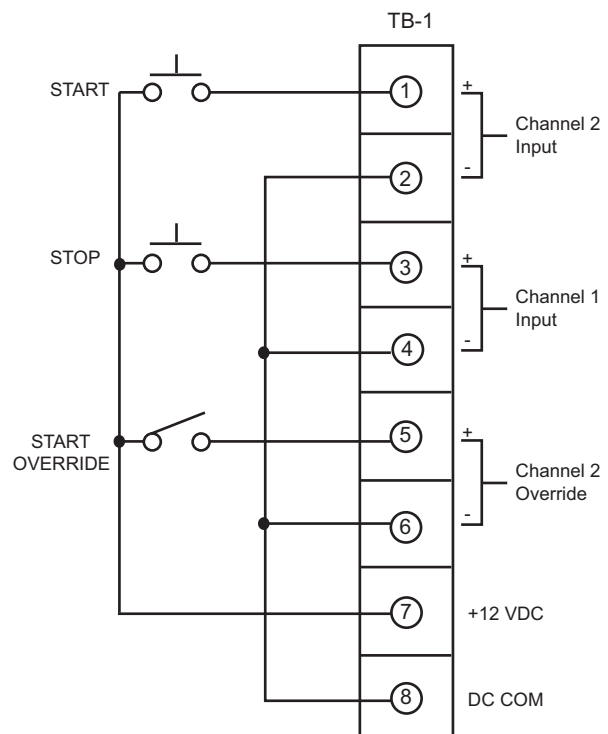

Figure 21a

Alternate Mode Operation (Single)

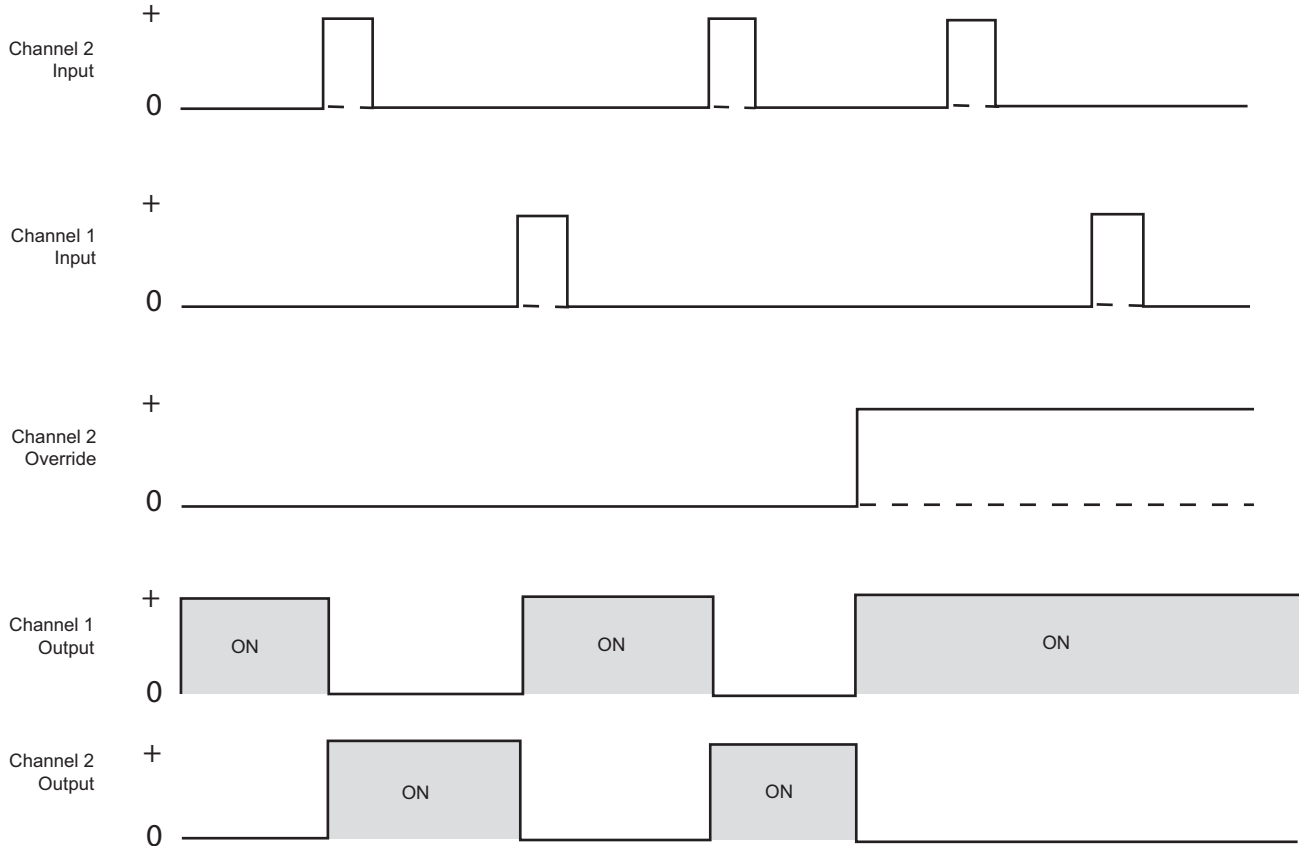

Figure 21b

Simultaneous Mode Operation

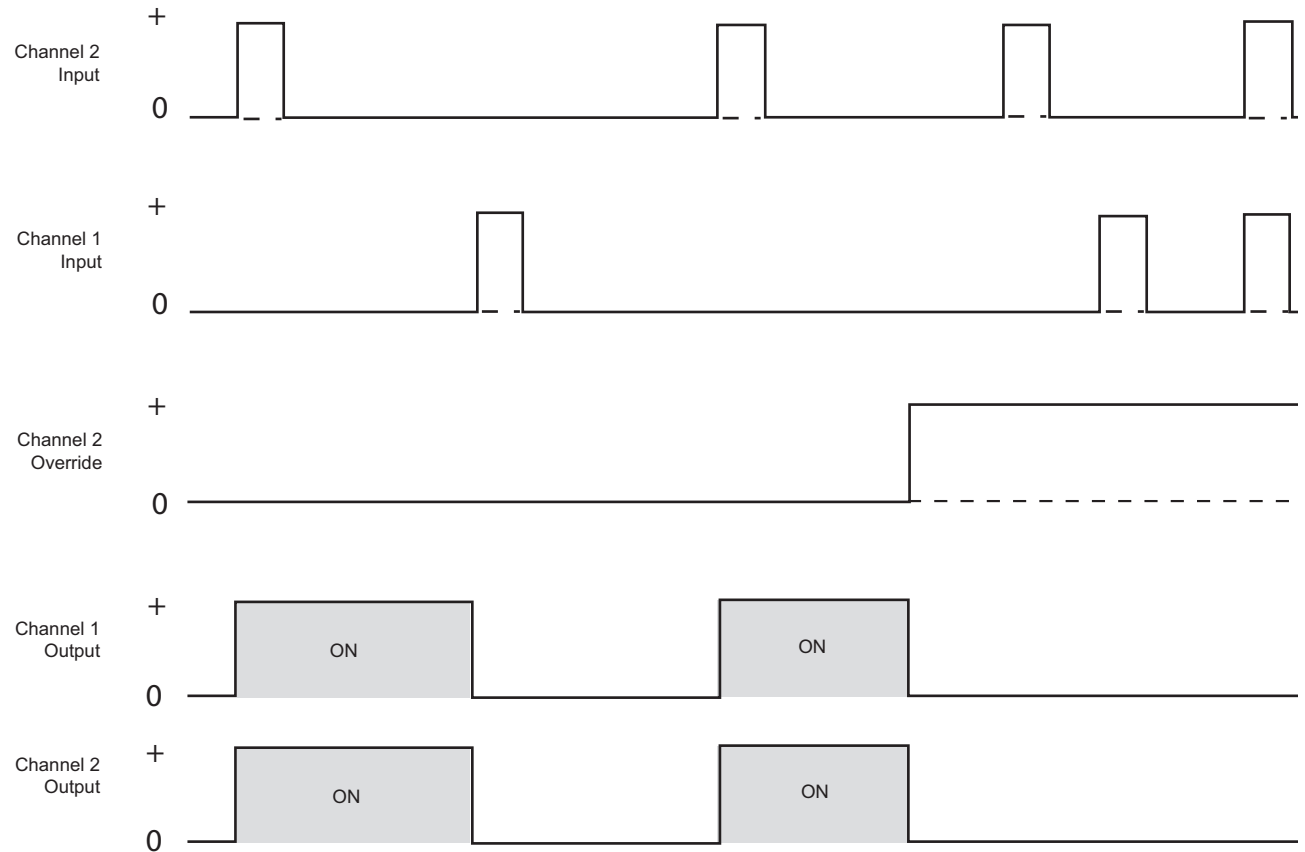

Figure 21c

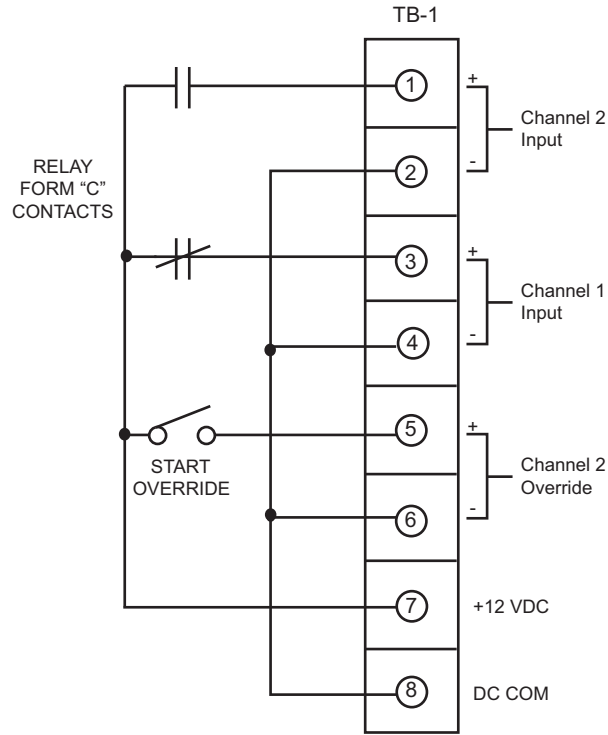

Figure 22a

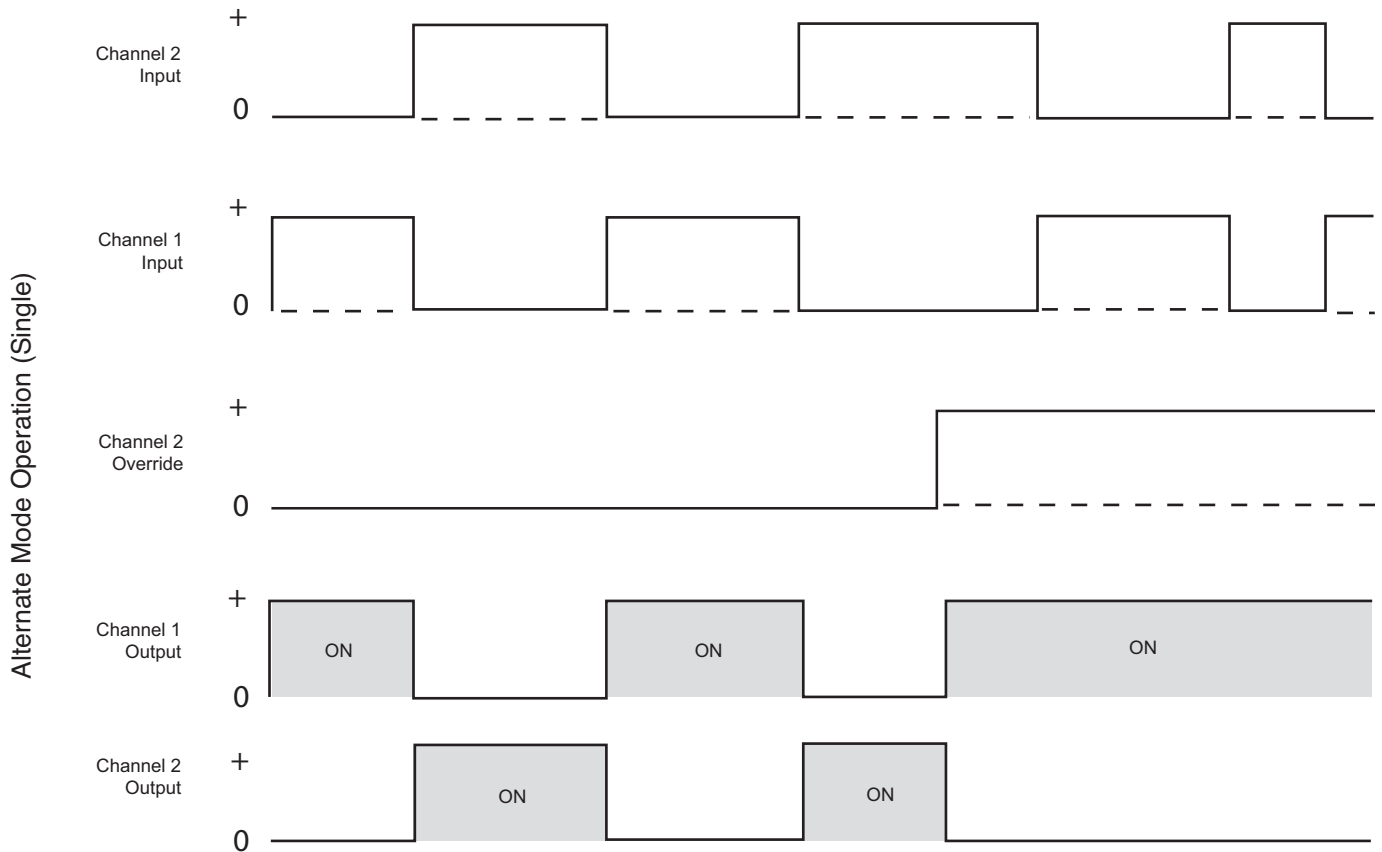

Figure 22b

Simultaneous Mode Operation

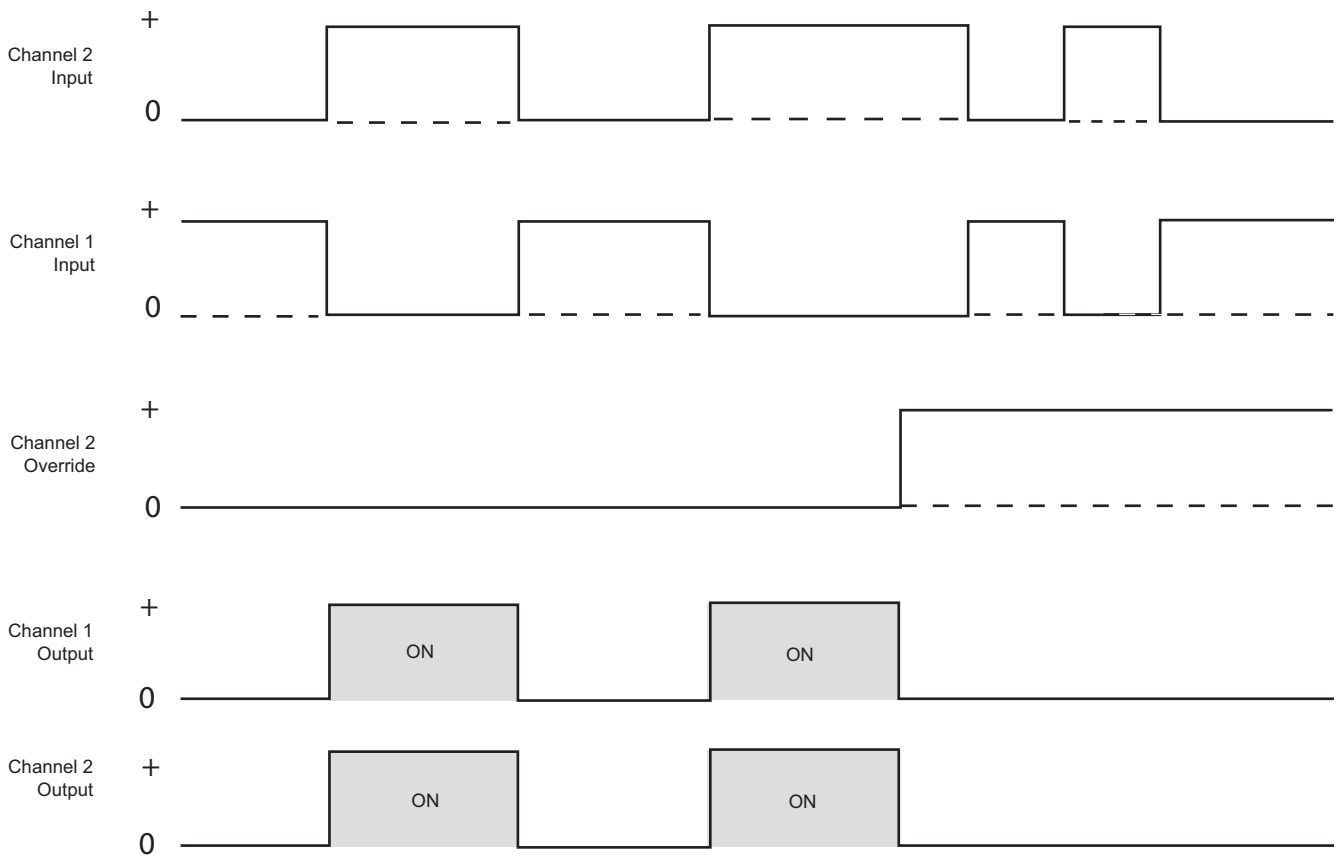

Figure 22c

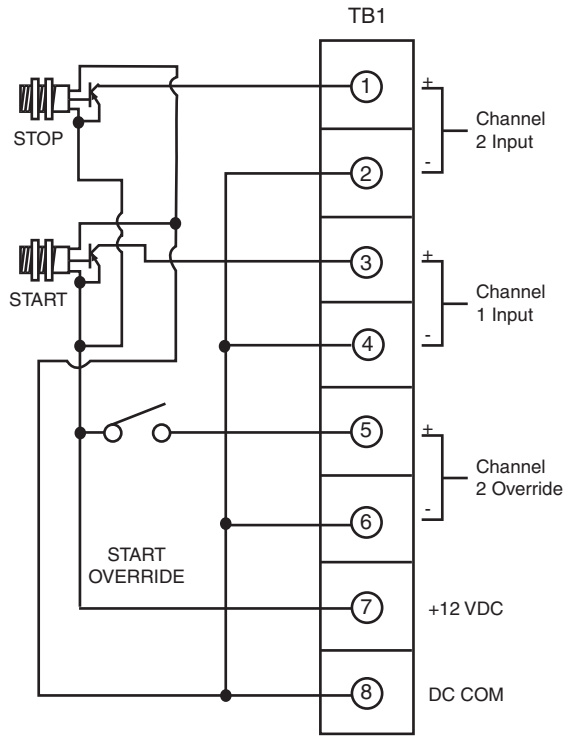

Figure 23a

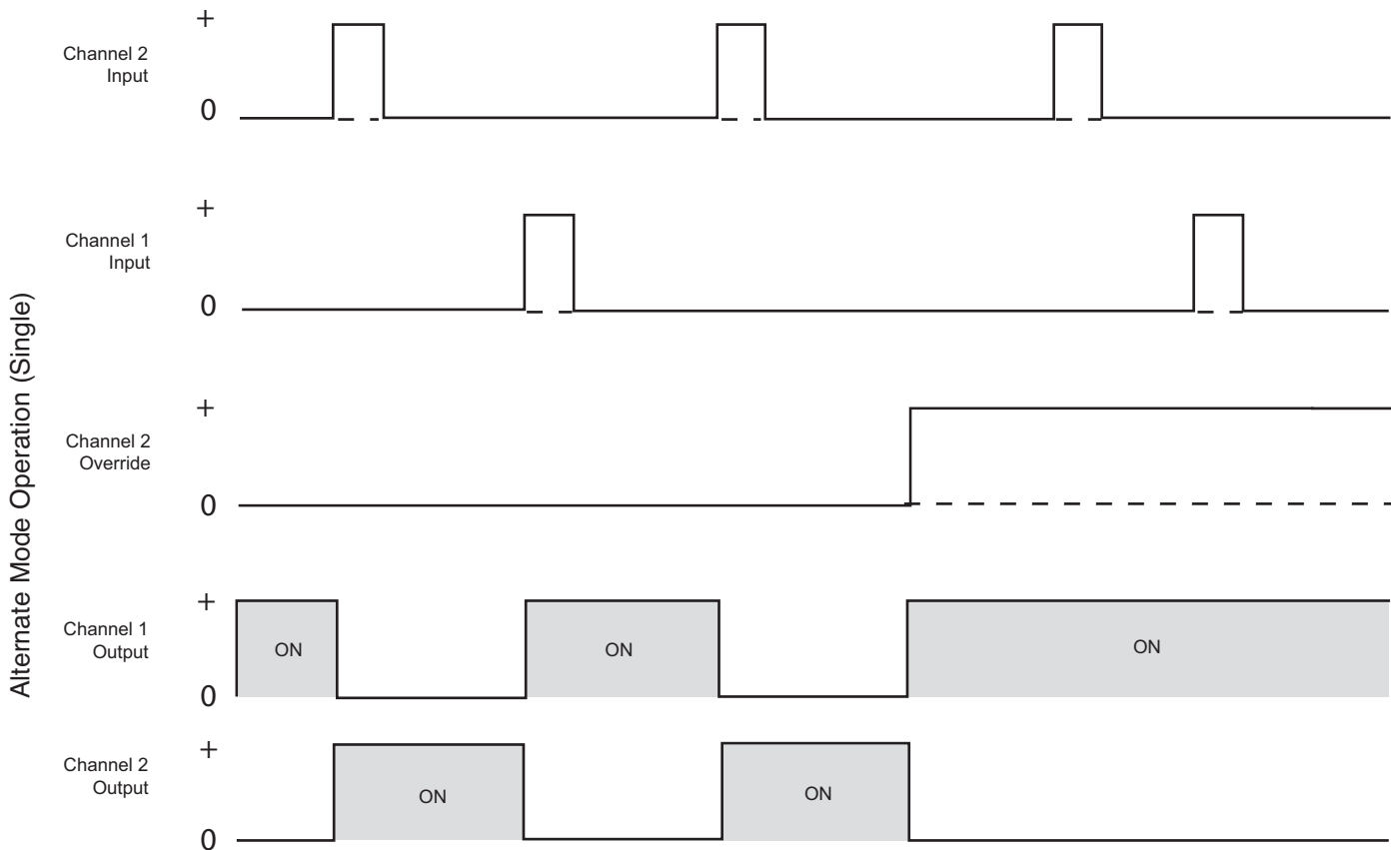

Figure 23b

Simultaneous Mode Operation

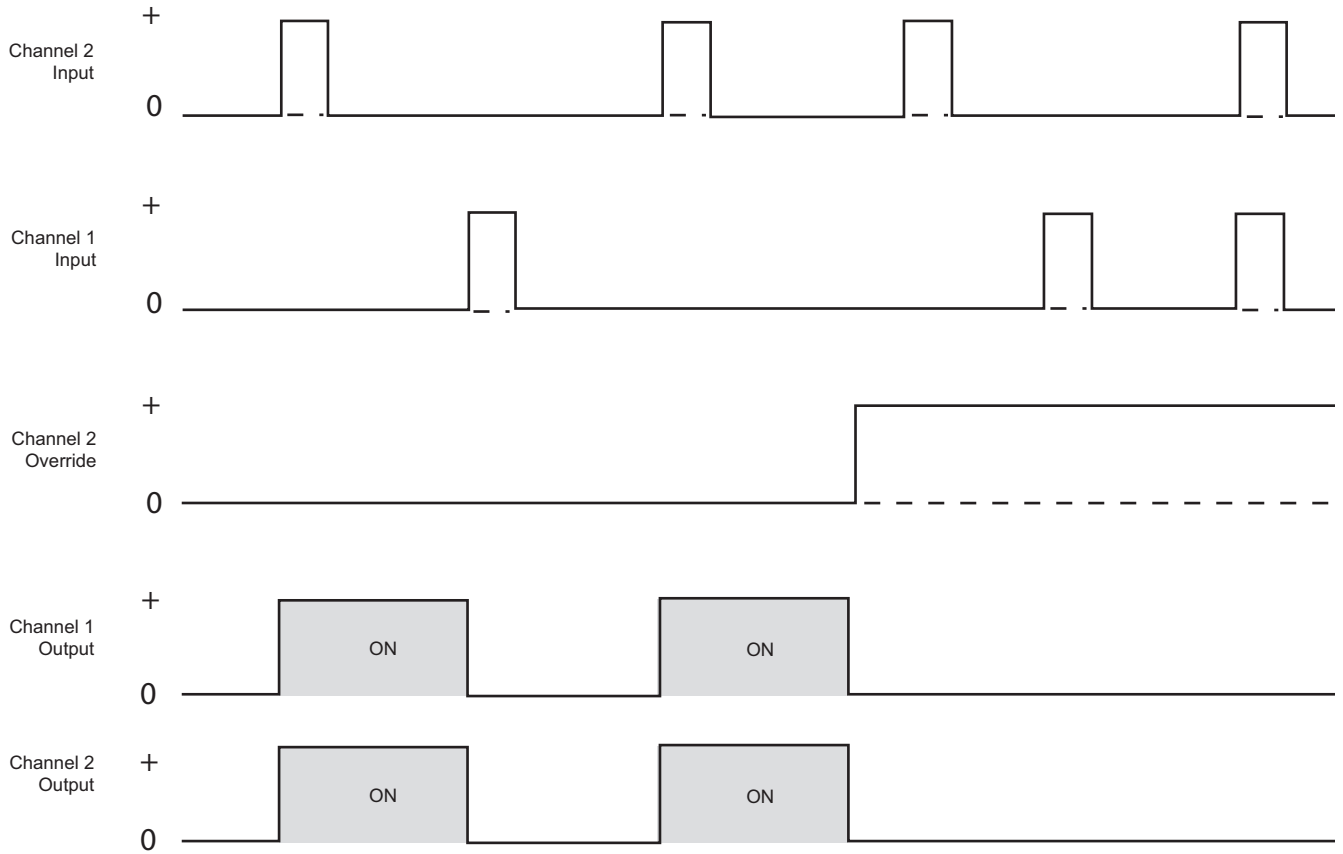

Figure 23c

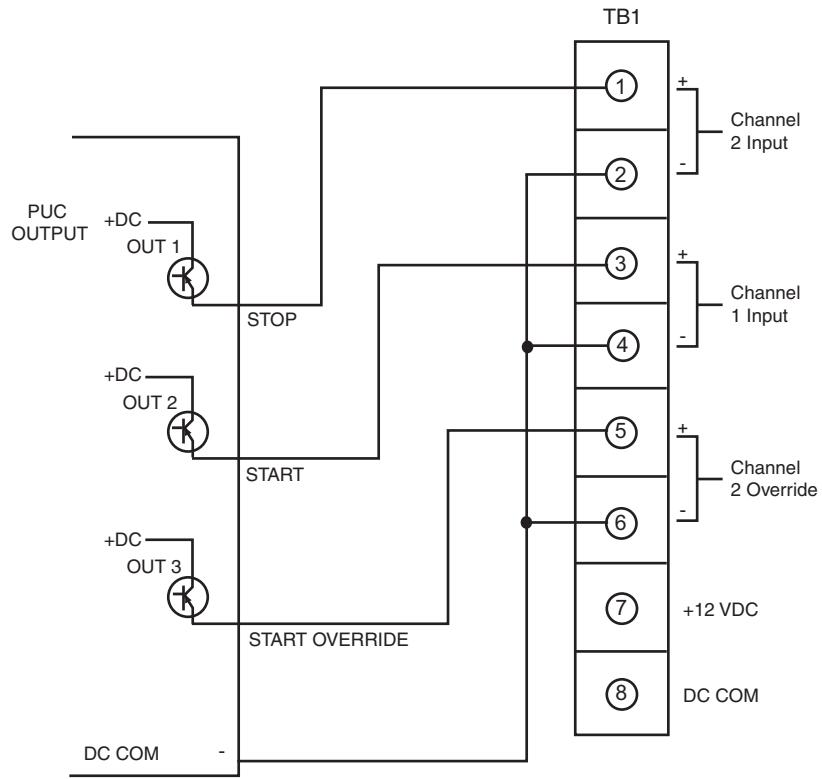

Figure 24a

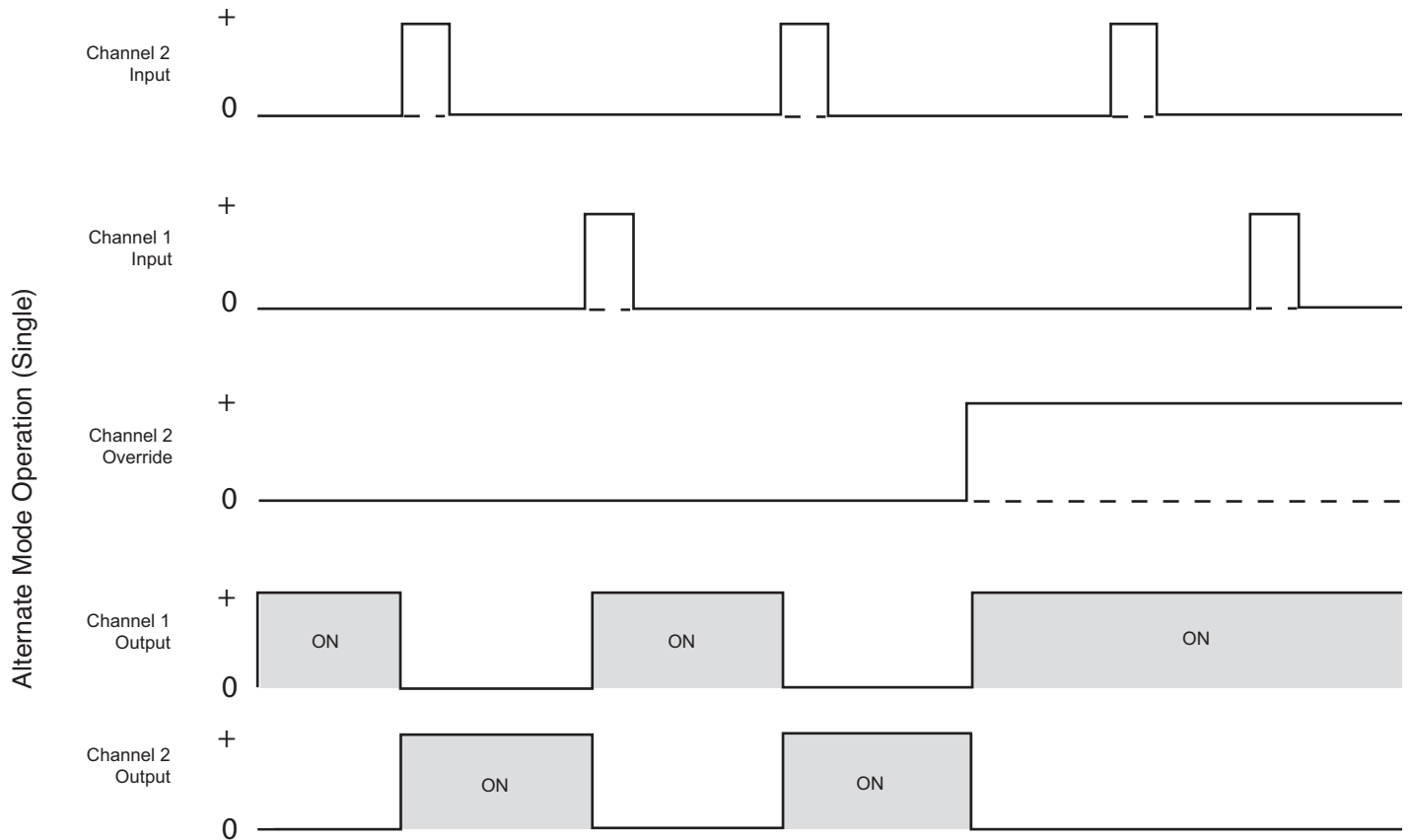

Figure 24b

Simultaneous Mode Operation

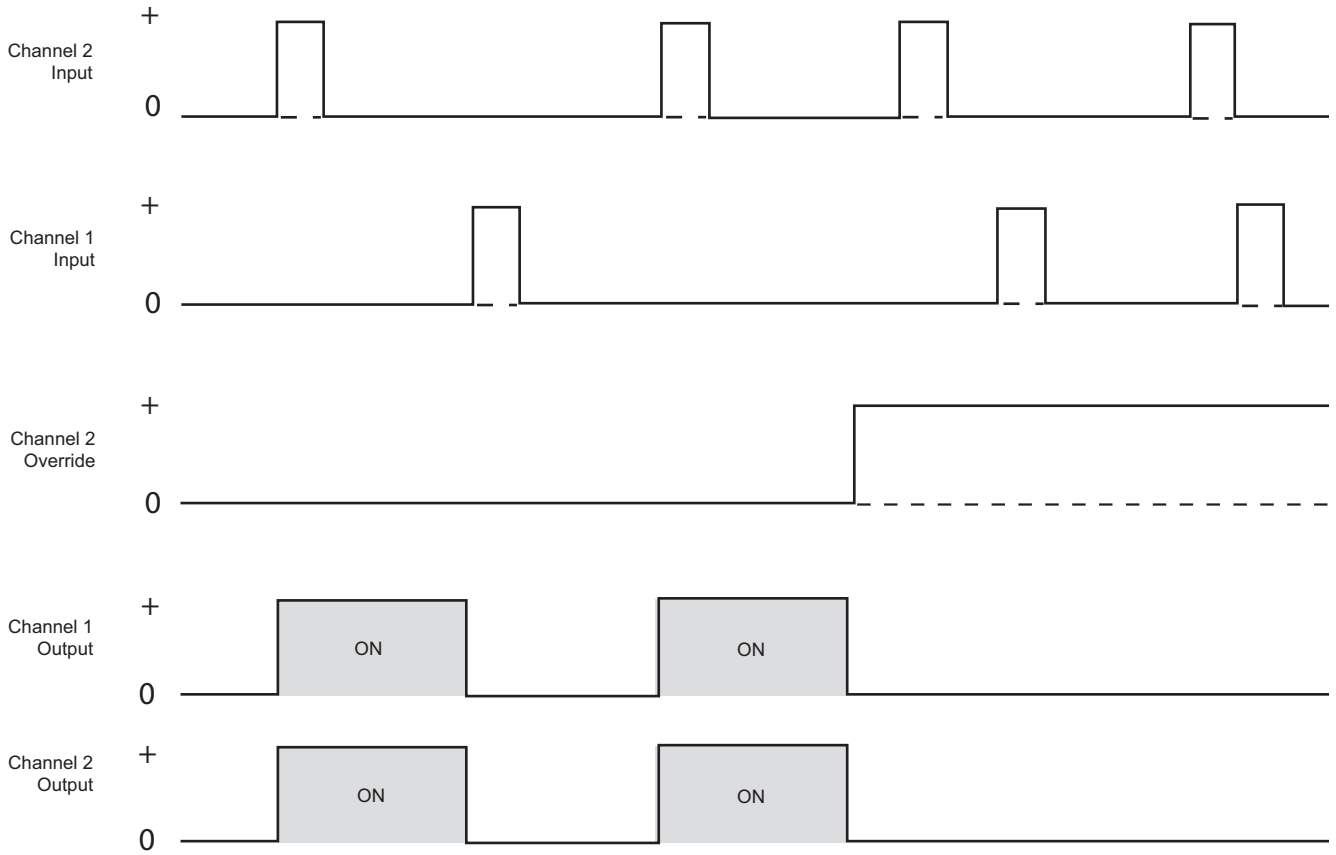

Figure 24c

Alternate/Simultaneous Operation – Two Wire Mode, Sourcing Type Input Devices

- 1. Refer to Figures 25a through 28a for various switching devices which can be used.
 - 2. Jumper the negative (-) inputs of the opto-coupler, Terminal Block TB-1, Terminals 2, 4, and 6 together. Tighten Terminals 2 and 4 of Terminal Block TB-1 securely. Snug Terminal 6 only at this time.
 - 3. Connect a DC power source, negative (-) or DC Common Terminal 6 of Terminal Block TB-1.
 - a. Negative (-) or DC Common of external DC power source to Terminal 6. Tighten Terminal 6 securely.

or,

 - b. Jumper from Terminal 8 of Terminal Block TB-1 DC Common (-) to Terminal 6 of Terminal Block TB-1 if internal DC power source is used. Tighten both Terminals 6 and 8 securely on Terminal Block TB-1.
- 4. Connect a DC power source positive (+) voltage to Terminal 1 of Terminal Block TB-1.
 - a. Positive (+) DC of external DC power source is used. Tighten Terminal 1, TB-1 securely.

or,

 - b. Jumper from Terminal 1 of Terminal Block TB-1 to Terminal 7 (+) DC of TB-1 if internal DC power supply is used. Tighten Terminal 1 only at this time.
- 5. Connect the output side of the switching circuit to the Channel 1 input, positive side (+) of the opto-coupler at Terminal Block TB-1, Terminal 3.
 - a. Normally closed contact of mechanical switch

- b. Normally closed contact of relay contact
- c. Open collector output of PNP Transistor (normally on) for solid-state sensors
- d. Collector output of PNP Transistor (normally on) for PLC output module or computer card

Tighten Terminal 3 of Terminal Block TB-1 securely.

NOTE: For operation of the CBC-400/CBC-450 to power up with Channel 1 output “on” in alternate mode or both outputs “off” in simultaneous mode, the Channel 1 input switch must be maintained closed for mechanical switches or “on” in the case of solid-state switches.

- 6. Connect the input side of the switching circuit when mechanical switches are used to the positive side (+) of the DC power source.
 - a. External positive (+) of the DC power source if used

or,

 - b. Positive (+) of the internal DC power source at Terminal 1 of Terminal Block TB-1 securely.
- Tighten Terminal 7 of TB-1 securely.
- 7. For external sensors or when using PLC output modules or computer cards, connect power source to sensors or cards accordingly.
 - a. External power source, positive (+) and negative (-) to appropriate leads on terminals

or,

 - b. Internal power source, positive (+) DC voltage Terminal 7 of Terminal Block TB-1 and negative (-) or DC Common Terminal 8 of Terminal Block TB-1 to appropriate sensor leads or terminals. Insure both Terminals 7 and 8 are snug at this time.
- 8. Optional Channel 2 Override Input Wiring

NOTE: If using the Channel 2 override input (start override) the switching circuit must be a maintained type so that Channel 1 input switching will have no effect on the output functions when maintained.

a. Connect the output side of the switching circuit to the Channel 2 override input, positive side (+) of the opto-coupler at Terminal 5 of Terminal Block TB-1.

- 1. Maintained switch, normally open contact
- 2. Normally open relay contact
- 3. Open collector output of PNP Transistor in PLC output module or computer card.

Tighten Terminal 5 of Terminal Block TB-1 securely at this time.

b. Connect the input side of the Channel 2 override switch to positive side (+) of the DC power source.

- 1. External positive (+) of external DC power source if used.

or,

2. Positive side (+) of the internal DC power source at Terminal 7 of Terminal Block TB-1. Tighten Terminal 7 securely at this time.

9. Double check all input wiring and switching circuit connections to insure proper wiring and hook-up. Refer to figures 25a through 28a.

10. Make sure all terminal block connections on TB-1 are securely tightened at this time.

11. Double check to insure any external sensor power wiring and connections are correct and secured properly. Refer to the appropriate sensor data sheets for connections.

12. This completes the input switching circuit wiring. Make sure all debris, insulation chips or wire fragments are cleaned up and control circuit boards blown off with dry air before proceeding.

13. Proceed to the start up section of the manual for start up and check out.

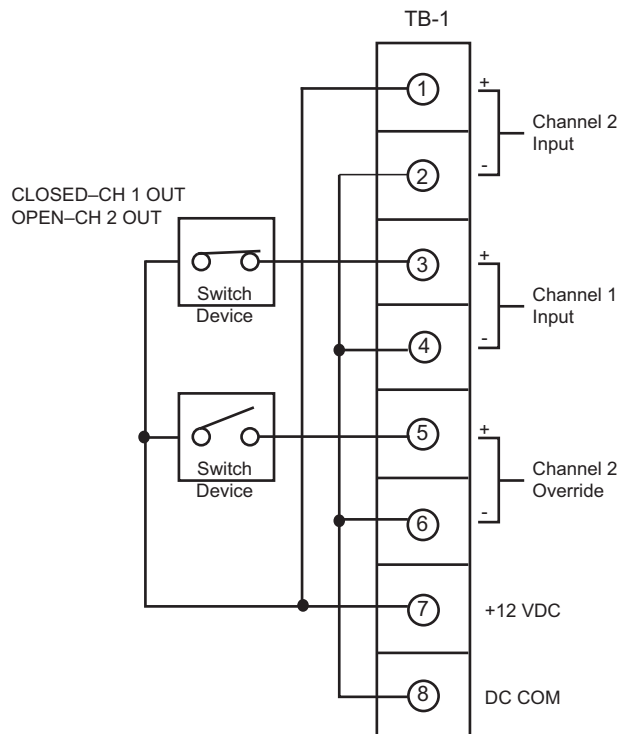

Figure 25a

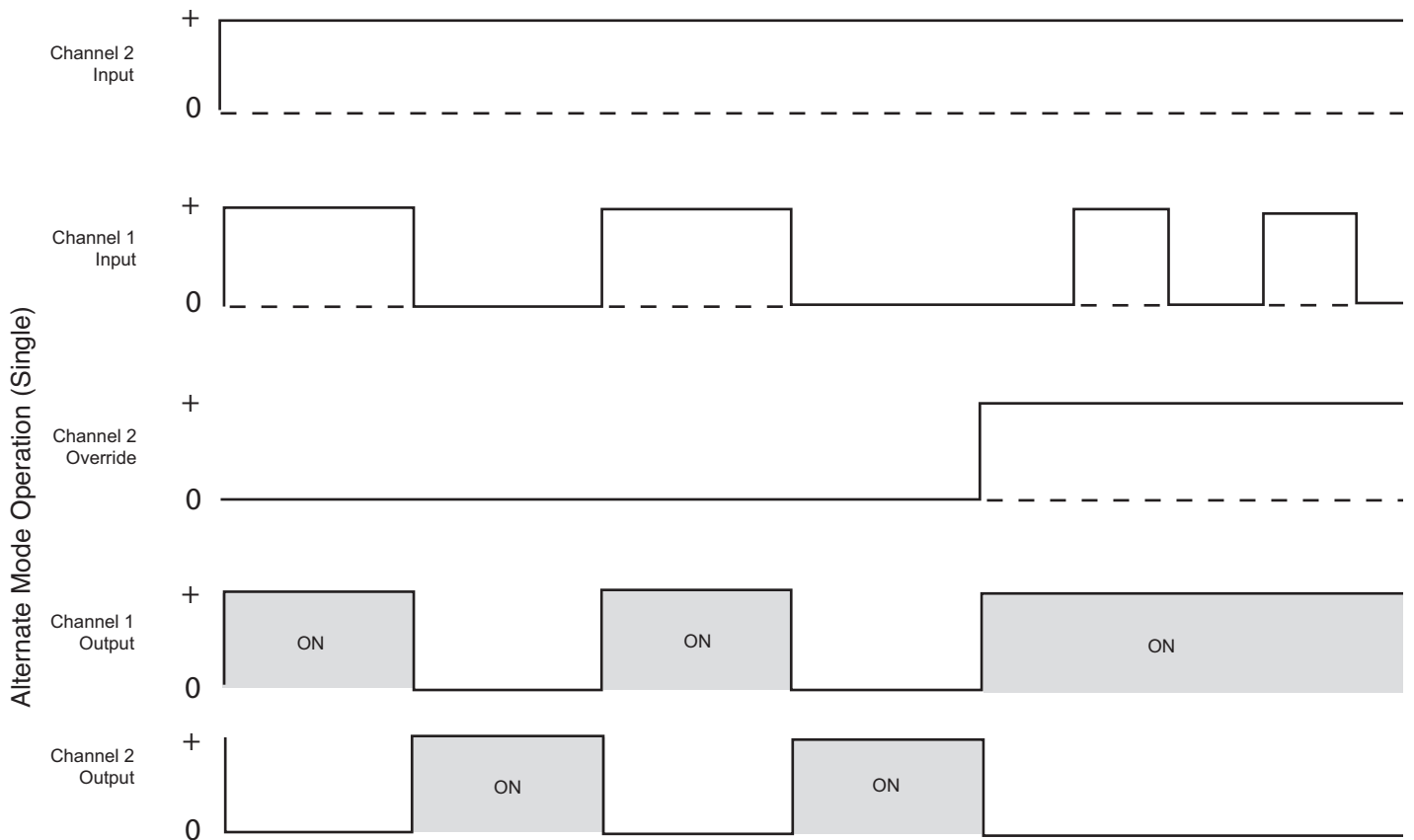

Figure 25b

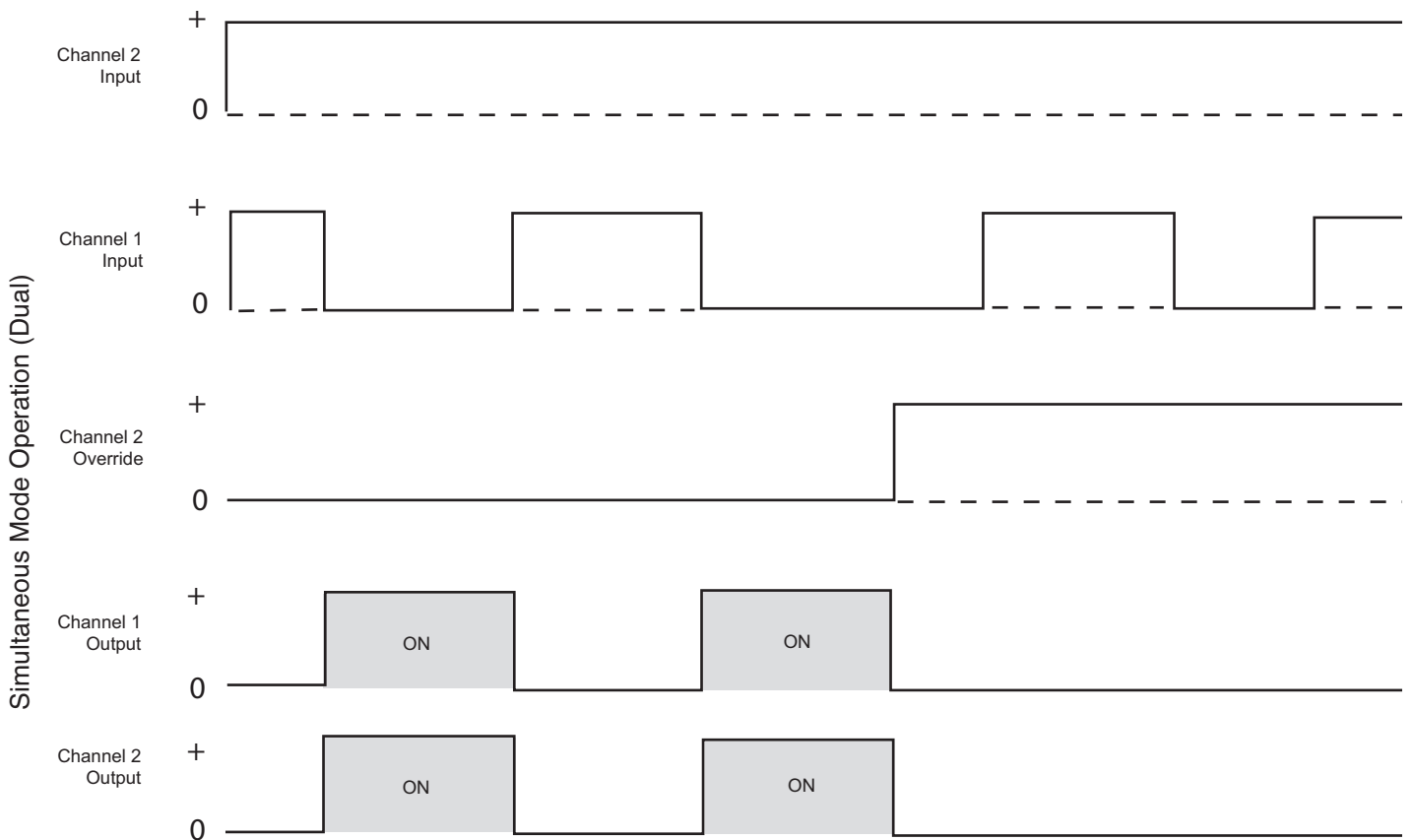

Figure 25c

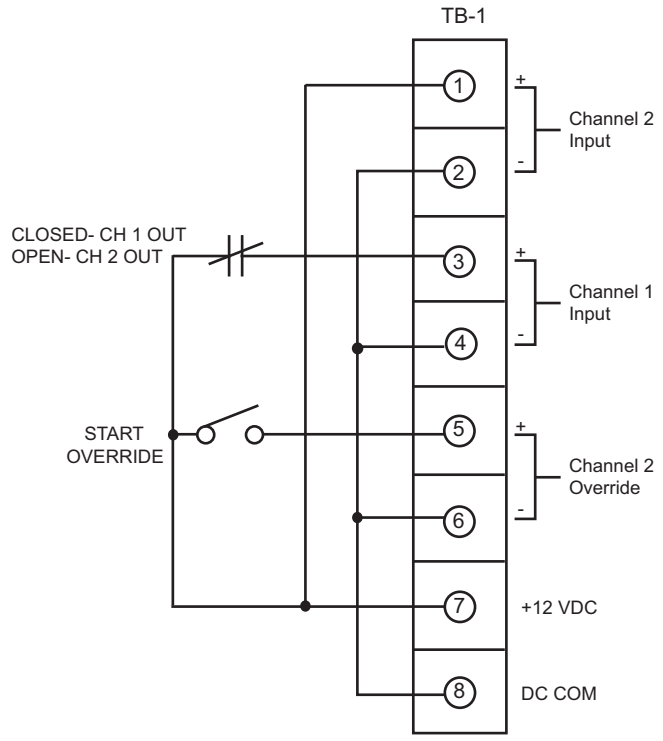

Figure 26a

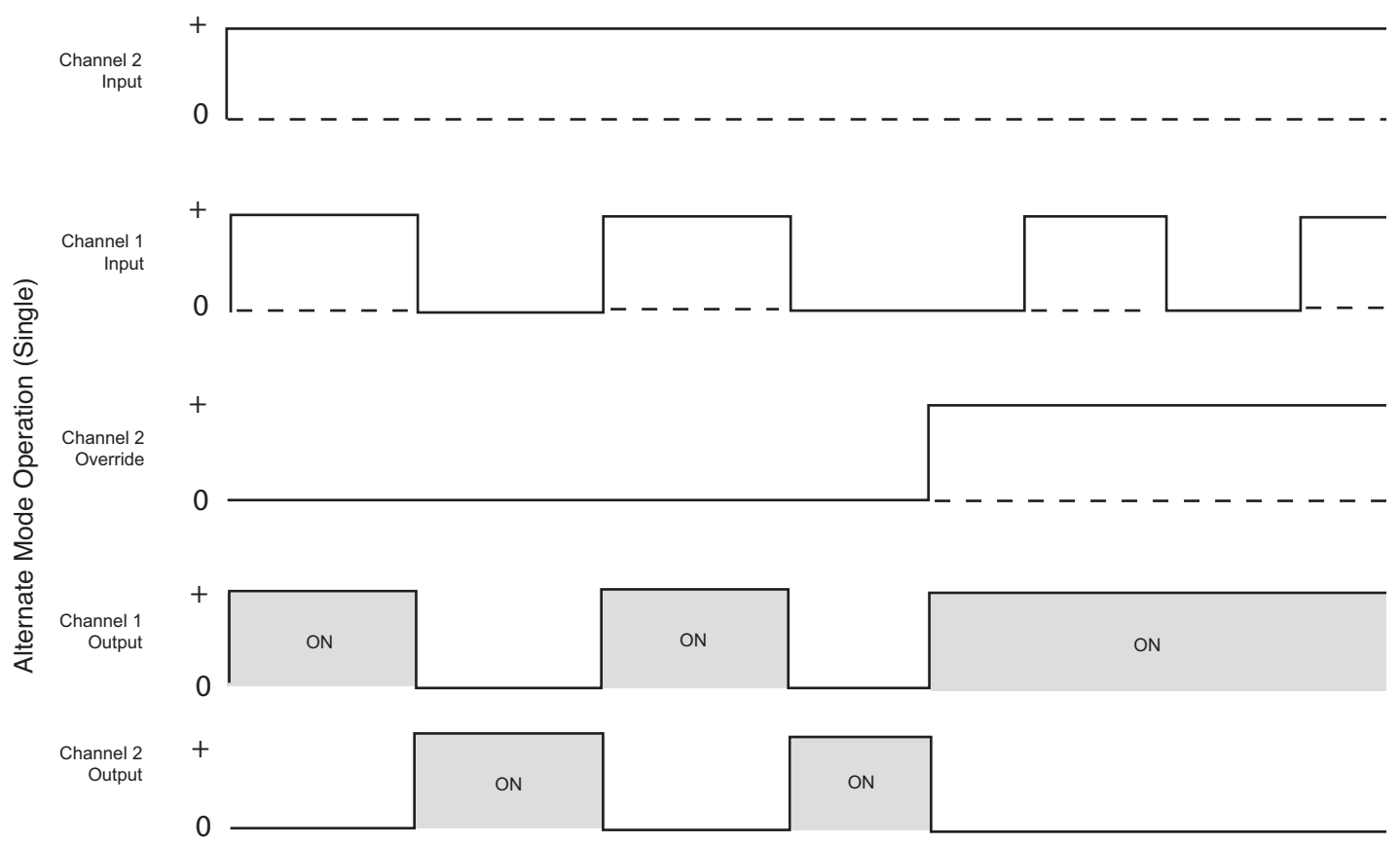

Figure 26b

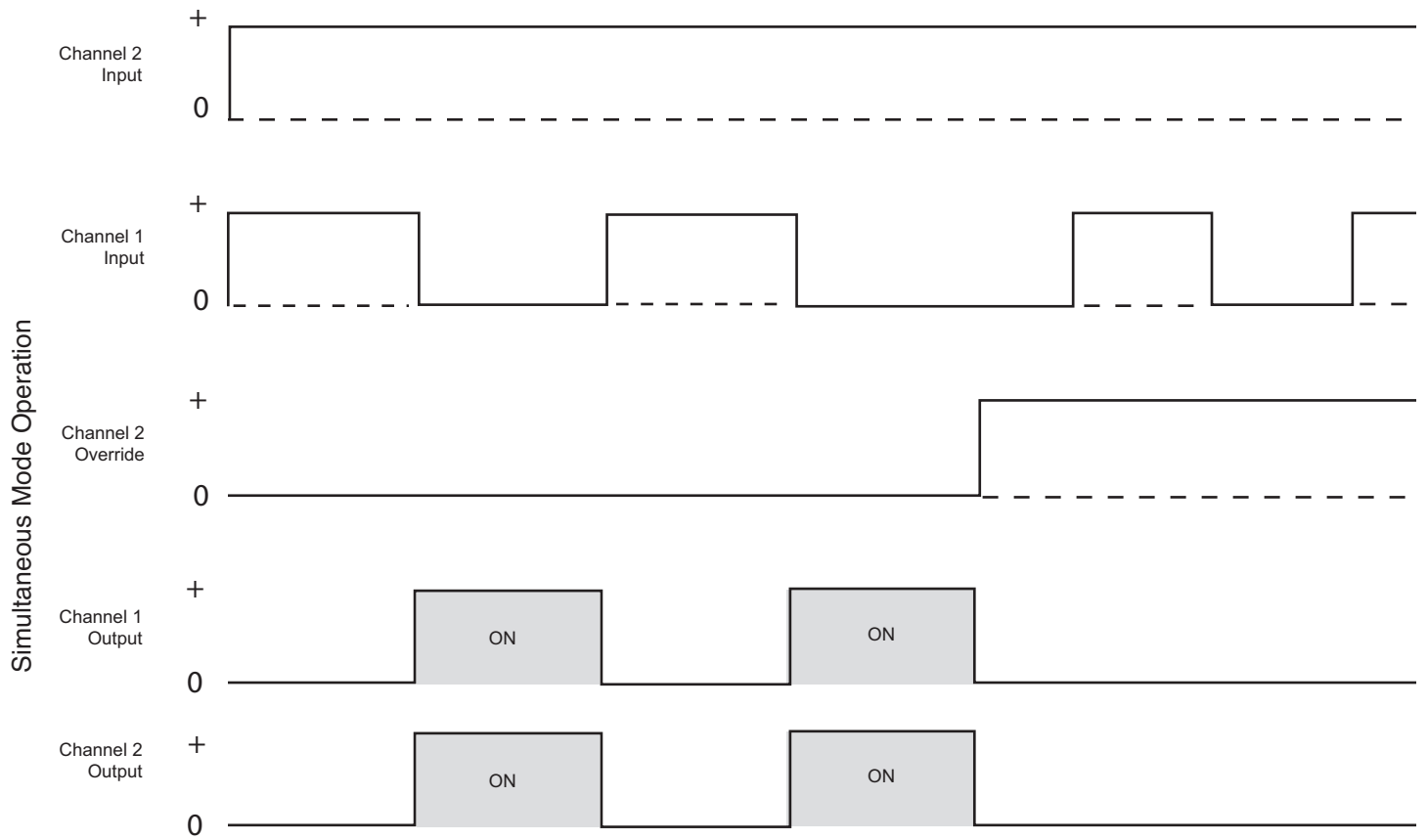

Figure 26c

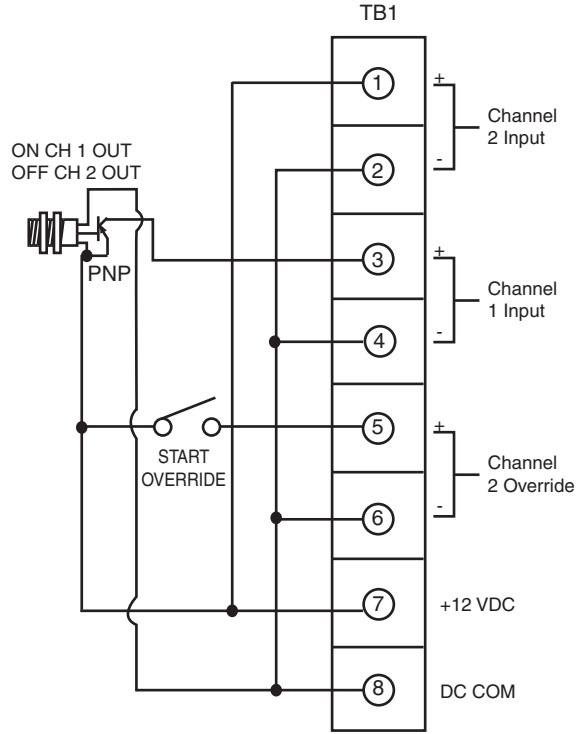

Figure 27a

Alternate Mode Operation (Single)

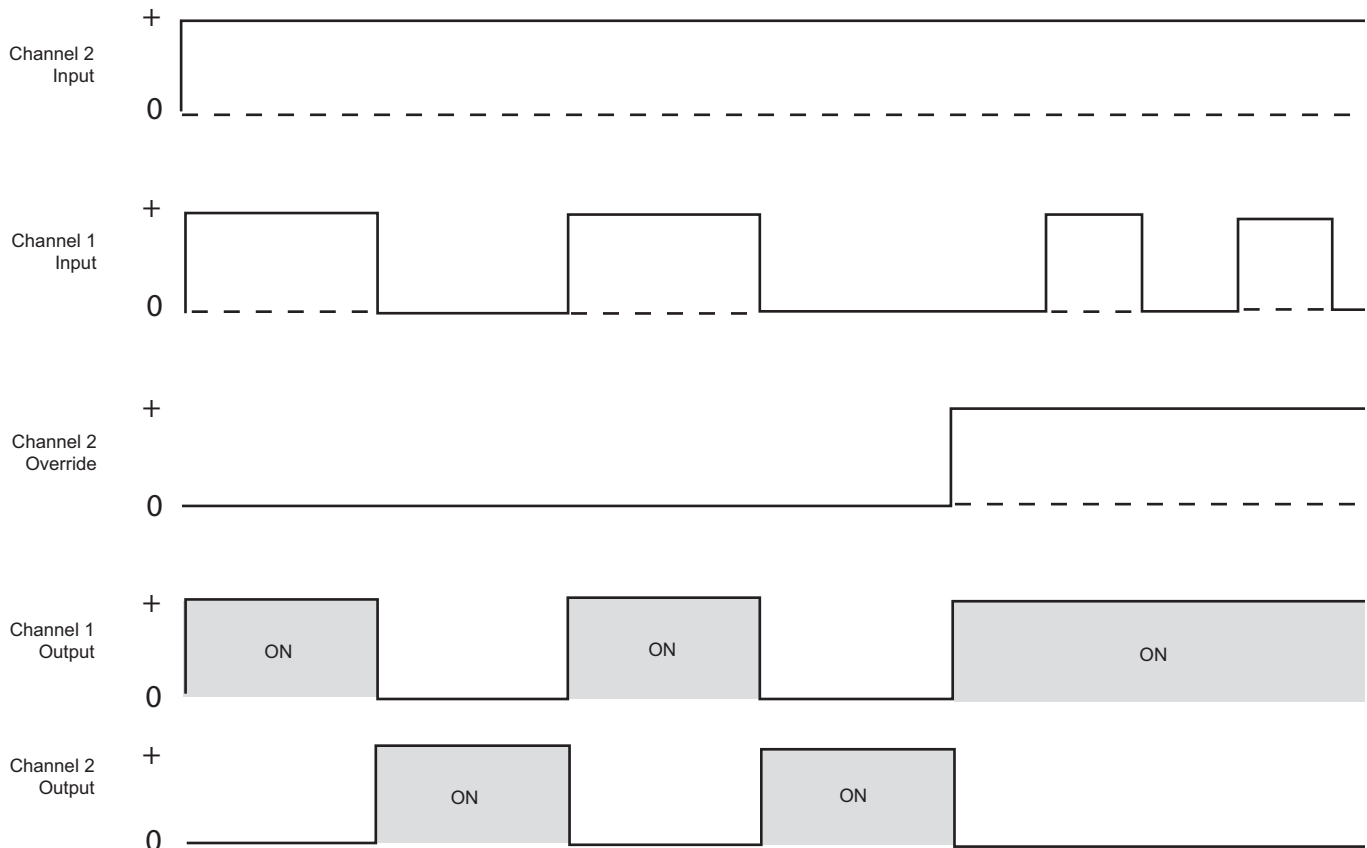

Figure 27b

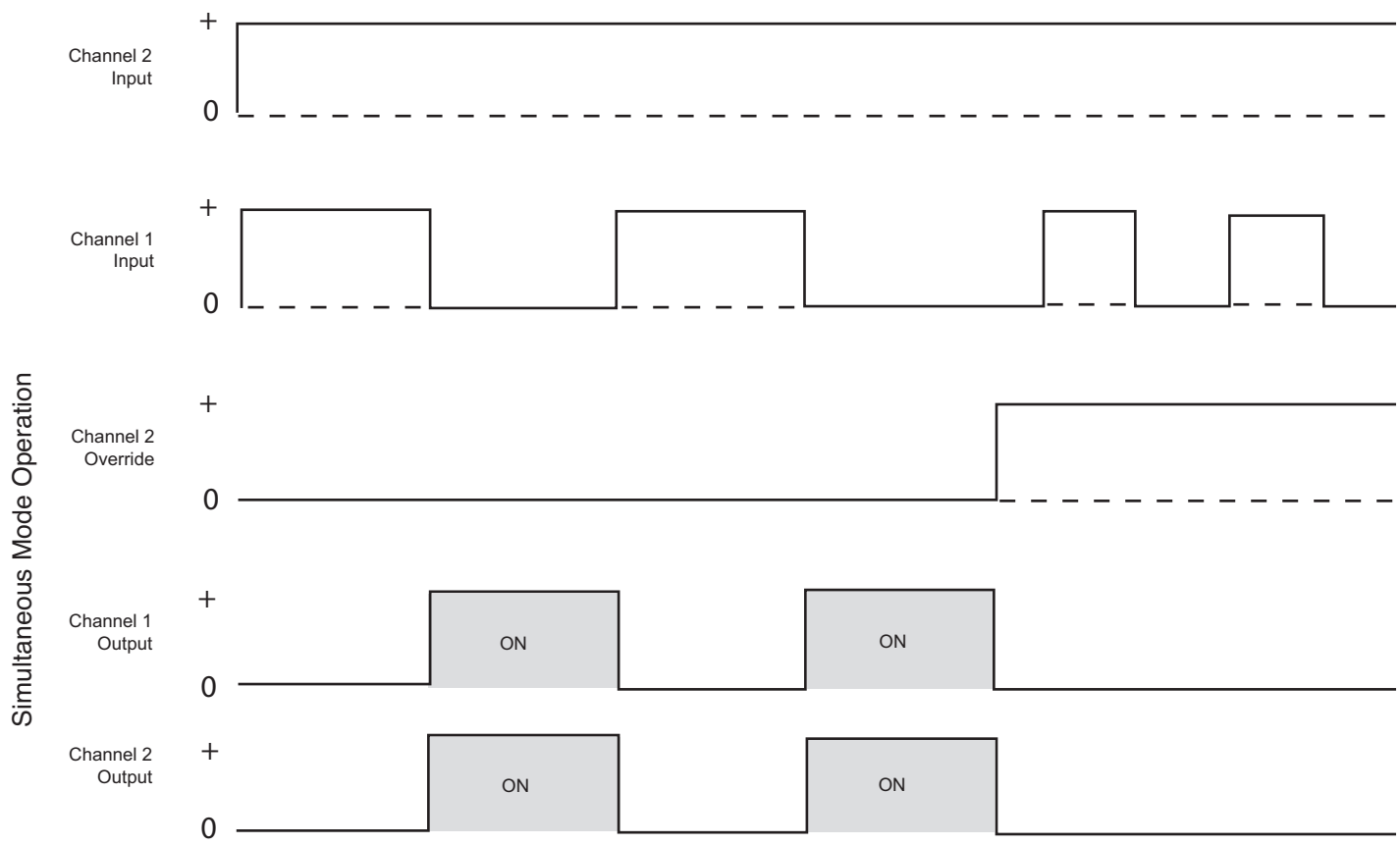

Figure 27c

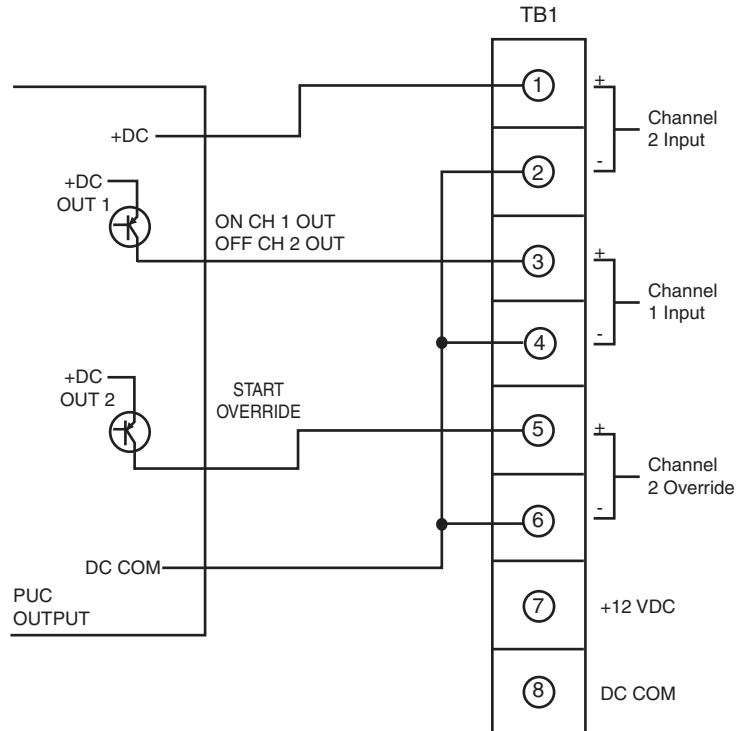

Figure 28a

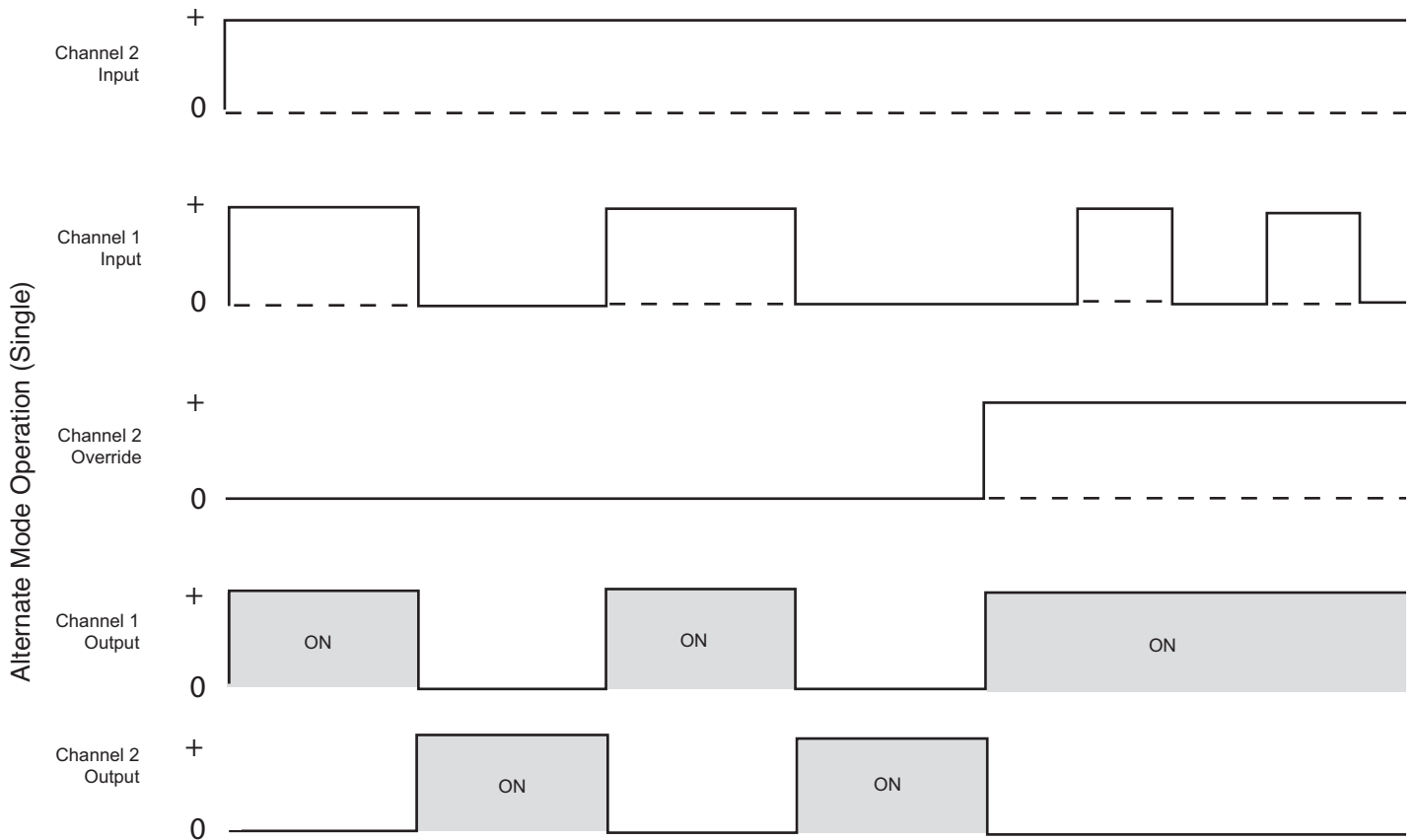

Figure 28b

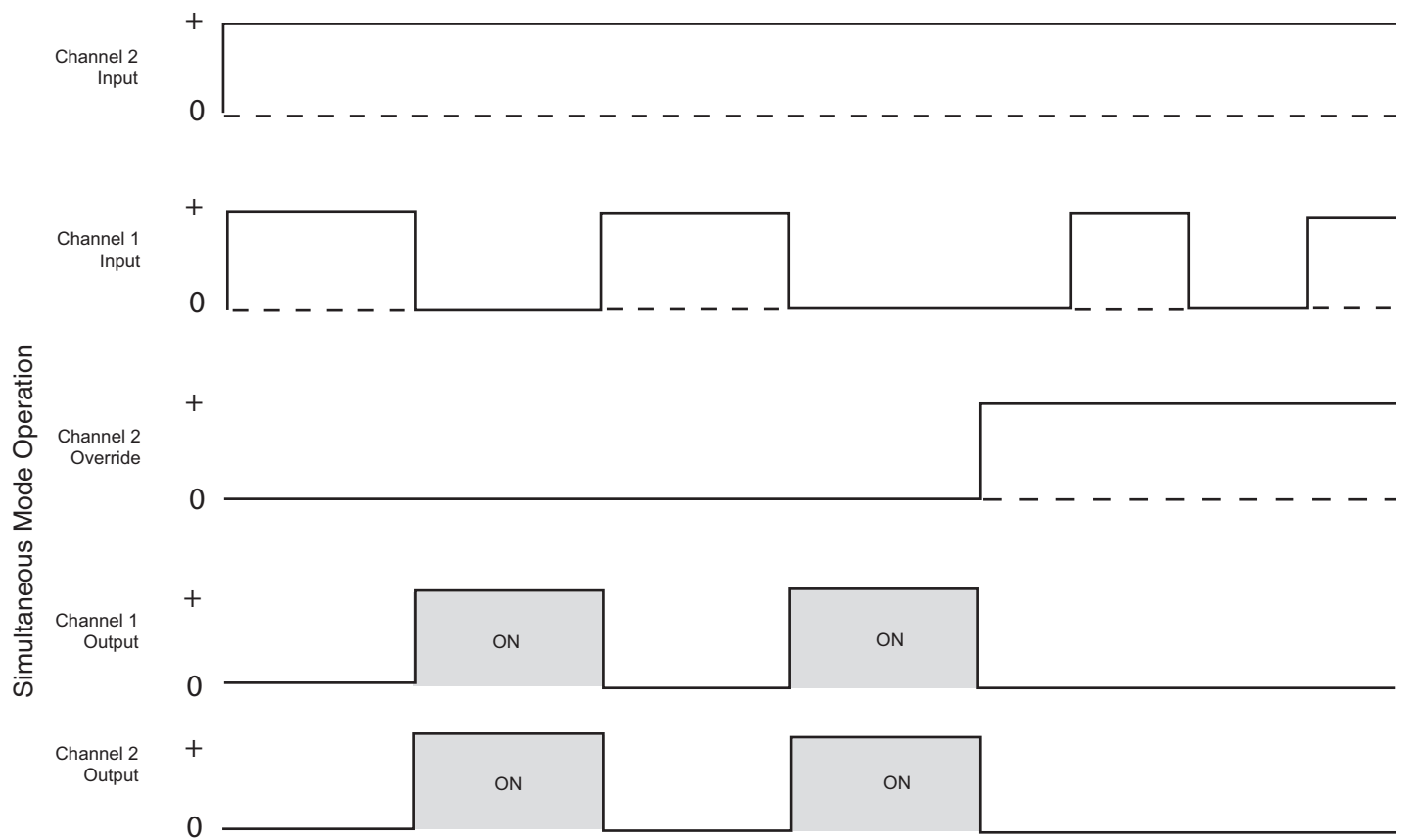

Figure 28c

Start up & Initial Check-Out

Start-up and check-out of the CBC-400/CBC-450 series of clutch/brake controls should be straight forward and simple if proper hook-up and connections were made per appropriate installation procedures.

Initial check-out can be accomplished statically without having the motor driving the system energized. Checks will be made to insure proper switching and output operation of the clutch/brake, clutches or brakes based on the operating mode and type of switching employed.

Refer to the following logic diagrams for proper switching and output functions based on various modes:

Alternate Mode, Three-Wire, Sinking.....	Figures 13b thru 16b
Simultaneous Mode, Three-Wire, Sinking	Figures 13c thru 16c
Alternate Mode, Two-Wire, Sinking	Figures 17b thru 20b
Simultaneous Mode, Two-Wire, Sinking	Figures 17c thru 20c
Alternate Mode, Three-Wire, Sourcing	Figures 21b thru 24b
Simultaneous Mode, Three-Wire, Sourcing.....	Figures 21c thru 24c
Alternate Mode, Two-Wire, Sourcing.....	Figures 25b thru 28b
Simultaneous Mode, Two-Wire, Sourcing	Figures 25c thru 28c

- | | |
|--|--|
| <p><input type="checkbox"/> 1. Apply AC power to the control. Check that proper outputs are activate based on operating modes and appropriate logic diagrams.</p> <p><input type="checkbox"/> 2. With the drive components still off-line, activate the appropriate inputs and determine that control switches output channels accordingly. Refer to the appropriate timing diagrams.</p> <p><input type="checkbox"/> 3. If using three-wire switching mode, alternate switching inputs and ensure outputs follow proper switching signals.</p> <p><input type="checkbox"/> 4. If Channel 2 override switching is used, switch control using normal switching inputs so that Channel 2 output is on (alternate mode) and switch Channel 2 override input. Insure Channel 1 output comes on when this occurs. If simultaneous mode is used, both output channels should switch off.</p> | <p><input type="checkbox"/> 5. If all switching functions and output functions operate correctly, system is ready for normal operation. If problems are encountered or system does not switch properly, refer to hook-up and troubleshooting sections of this manual. If this fails to correct the problem, contact your local Warner Electric Representative or the Technical Support Department at 1-800-825-9050 for further assistance.</p> <p><input type="checkbox"/> 6. This completes the preliminary check-out and start-up of your control. Turn off power and secure any enclosure or panel being used. The system is now ready to run.</p> |
|--|--|

System Troubleshooting

The chart below will be helpful when attempting to isolate problems which may be encountered in the control system. It can also prove useful when problems are encountered during initial start-up. By no means does this represent every possible problem which can occur, but highlights the most common problems that are typically encountered.

Probable Cause	Suggested Solution
No output on either Channel during power up	<ul style="list-style-type: none"> • Improper wiring – check wiring and correct • No power available – check AC input power • Blown fuse – check input fuse and replace • Wires not inserted into TB's – correct and secure
Fuse keeps blowing	<ul style="list-style-type: none"> • Incorrect wiring – check wiring and replace fuse • Incorrect AC line voltage applied – correct line voltage and replace fuse • Fuse size too small (rating) – check fuse ratings and replace with correct value • Incorrect magnet voltage – check coil ratings of magnets and replace with correct magnets if necessary • Shorted magnet coil – check magnet coil resistance for proper valve and replace if necessary
Channel 2 activates on power up	<ul style="list-style-type: none"> • Incorrectly wired – check control wiring and rewire if necessary • Input switching faulty – check input switching device and replace if necessary • Incorrect input logic from switching device – verify and change as necessary
Output channels do not switch, inputs do not switch	<ul style="list-style-type: none"> • Incorrect wiring – check wiring and correct if necessary • No AC input – check for AC input voltage to control and correct if necessary • Incorrect or faulty switching devices – check for proper operation and outputs and replace if necessary • AC input fuse blown – check for blown fuse and replace if necessary • Control is faulty – replace control
Magnets do not appear to have sufficient torque	<ul style="list-style-type: none"> • Incorrectly sized magnets – verify sizing and selection for application and resize if necessary • Full output voltage not applied to magnets – check for faulty control or proper magnet voltages selected for control voltage (90v magnet on 24v control) • AC input voltage below minimum – check for proper AC voltage and correct if necessary

Ordering Information

MODEL	PART NUMBER
CBC-400-24	6006-448-002
CBC-400-90	6006-448-003
CBC-450-24	6006-448-005
CBC-450-90	6006-448-006
CBC-400 Series Enclosure	6042-101-004
CBC-450 Series Enclosure	6006-101-007

DECLARATION OF CONFORMITY

WE: **WARNER ELECTRIC**
449 Gardner Street
South Beloit, IL 61080

declare under our sole responsibility that the products of the family
CBC 400-90, CBC 400-24
CBC 450-90 & CBC450-24

are exclusively designed for incorporation in another machine. The operation of the product is submitted to the conformity of the complete equipment, following the provisions of the directive **89/392/EEC**.

The conformity of the above specified products with the provisions of the Directive **72/23/EEC** is supported by the full respect of the standards **EN 61010-1**.

If the mounting and connecting instructions of the installation manual have been respected, this product will be conforming to the standards **EN50081-1** and **EN50082-1** relating to the EMC directive **89/336/EEC**.

South Beloit, IL 61080
General Manager: S. O.



⚠ WARNING To avoid injury, always make certain all power is off before attempting to install or repair this control.

DO NOT TOUCH THE BOARD IF POWER IS APPLIED.

Mounting and Connecting Instructions

related to the EMC-directive 89/336/EEC

For Clutch and Brake Control

1. The control must be mounted in a closed metal cabinet.
2. The power connection between control and clutch/brake must be MADE using shield cable.
3. The control connection must utilize shielded cables.
4. The shield of the cables must be grounded at both ends.
5. Power connections and control connection must be placed in separate canals.

KONFORMITÄTSEKLRÄRUNG

Wir: **WARNER ELECTRIC**
449 Gardner Street
South Beloit, IL 61080

erkären in alleiniger Verantwortung, daß die Produkte der Familie
CBC 400-90, CBC 400-24
CBC 450-90 & CBC450-24

ausschließlich zum Einbau in eine andere Maschine bestimmt sind. Die Inbetriebnahme ist solange untersagt, bis die Konformität des Endproduktes mit der Richtlinie **89/392/EWG** gegeben ist.

Die Übereinstimmung des bezeichneten Produktes mit den Vorschriften der Richtlinie **72/23/EWG** wird nachgewiesen durch die Einhaltung der Normen **EN 61010-1**.

Sofern die Montage-Anweisungen der Bedienungsanleitung eingehalten wurden, ist dieses Produkt konform zu **EN50081-1** und **EN50082-1** und die EMV somit gewährleistet - Richtlinie **89/336/EWG**.

South Beloit, IL 61080
General Manager: S. O.



⚠ WARUNG: Vor Einbau oder Wartung des Gerätes unbedingt die Stromversorgung unterbrechen um Verletzungen zu vermeiden.

KARTE BEI EINGESCHALTETER STROMVERSORGUNG NICHT BERÜHREN.

MONTAGE UND KABELVERBINDUNGEN ANWEISUNGEN

bezogen zu den EMW Richtlinie 89/336/EWG

FÜR STEURGERÄTE KUPPLUNGEN UND BREMSEN

1. Das Gerät muß in einem geschlossenen metallschrank eingebaut werden.
2. Leistungsverbindungen Steuergeräte/Kupplungen - Bremsen mit abgeschim Kabel durchfubren.
3. Steuerleitungen, Ein-und Ausgänge mittels abgeschimten Kabeln durchfuhren.
4. Abschirmung an beiden Enden des Kabels erden.
5. Leistungs-und Steuerverbindungen in separate Kabelkanäle durchziehen.

DECLARACION DE CONFORMIDAD

Nosotros: **WARNER ELECTRIC**
449 Gardner Street
South Beloit, IL 61080

declaramos bajo nuestra propia responsabilidad que los productos de la familia

CBC 400-90, CBC 400-24
CBC 450-90 & CBC450-24

son diseñados exclusivamente para incorporarse en otra maquina. El funcionamiento de este producto esta sujeto al cumplimiento de todo el equipo usado en la maquina, con los lineamientos de la norma **89/392/EEC**.

El cumplimiento de los lineamientos de la norma **72/23/EEC** con los productos mencionados anteriormente, se basa y respeta los estandares **EN 61010-1**.

Si las instrucciones de montaje e instalación electrica del instructivo son respetadas, este producto cumplirá con los estandares **EN50081-1** y **EN50082-1** que se relacionan con la norma **89/336/EEC**.

South Beloit, IL 61080
General Manager: S. O.



⚠ ADVERTENCIA: Para evitar cualquier daño personal, antes de intentar instalar o reparar este control, siempre asegurese que todas las fuentes de poder esten apagadas.

NO TOQUE EL CIRCUITO ELECTRICO SI LA FUENTE DE PODER ESTA ENCEDIDA.

INSTRUCCIONES DE MONTAJE Y CONEXIONES ELECTRICAS

en relación a la norma de EMC 89/336/EEC

PARA CONTROLES DE CLUTCHES Y FRENOS

1. El control debe de instalarse adentro de una caja metalica.
2. Las conexiones electricas entre el control y el cluch/freno DEBEN hacerse con cable blindado.
3. Las conexiones de bajo voltaje en el control deben utilizar cables blindados.
4. El blindaje de los cables debe de aterrizzarse en ambos lados.
5. Las conexiones entre la fuente de poder, y las conexiones de bajo voltaje deben de hacerse en diferentes cables.

DÉCLARATION DE CONFORMITÉ

Nous: **WARNER ELECTRIC**
449 Gardner Street
South Beloit, IL 61080

déclarons sous notre seule responsabilité que les produits de la famille
CBC 400-90, CBC 400-24
CBC 450-90 & CBC450-24

sont uniquement destinés à l'intégration dans une machine. La mise en service de ces produits est subséquente à l'homologation de l'ensemble de l'équipement, conformément à la directive **89/392/CEE**.

La conformité des produits spécifiés ci-dessus avec les exigences de la directive **72/23/CEE** est supportée par le respect des normes **EN 61010-1**.

Si les instructions de montage et de câblage du manuel sont respectées, ce produit est conforme aux normes **EN50081-1** et **EN50082-1** directive **89/336/CEE** relative à la CEM.

South Beloit, IL 61080
General Manager: S. O.



⚠ ADVERTISSEMENT: Afin d'éviter des blessures, s'assurer que toute puissance soit coupée avant installation ou intervention sur ces équipements.

NE PAS TOUCHER LE CIRCUIT ÉLECTRONIQUE, SI LA PUISSANCE EST APPLIQUÉE.

INSTRUCTIONS D'INSTALLATION ET DE CABLAGE

relatives à la CEM, directive 89/336/CEE

DES CONTROLES POUR EMBRAYAGES ET FREINS

1. L' appareil doit être monté dans une armoire métallique close.
2. Liaison de puissance entre contrôle et embrayage/frein par câble blindé.
3. Raccordements de consigne, entrées et sorties par câbles blindés.
4. Les blindages sont reliés à la terre aux deux extrémités du câble.
5. Les câbles de commande et les câbles de puissance ne seront pas placés dans le même caniveau.

Mounting Template for CBC-400

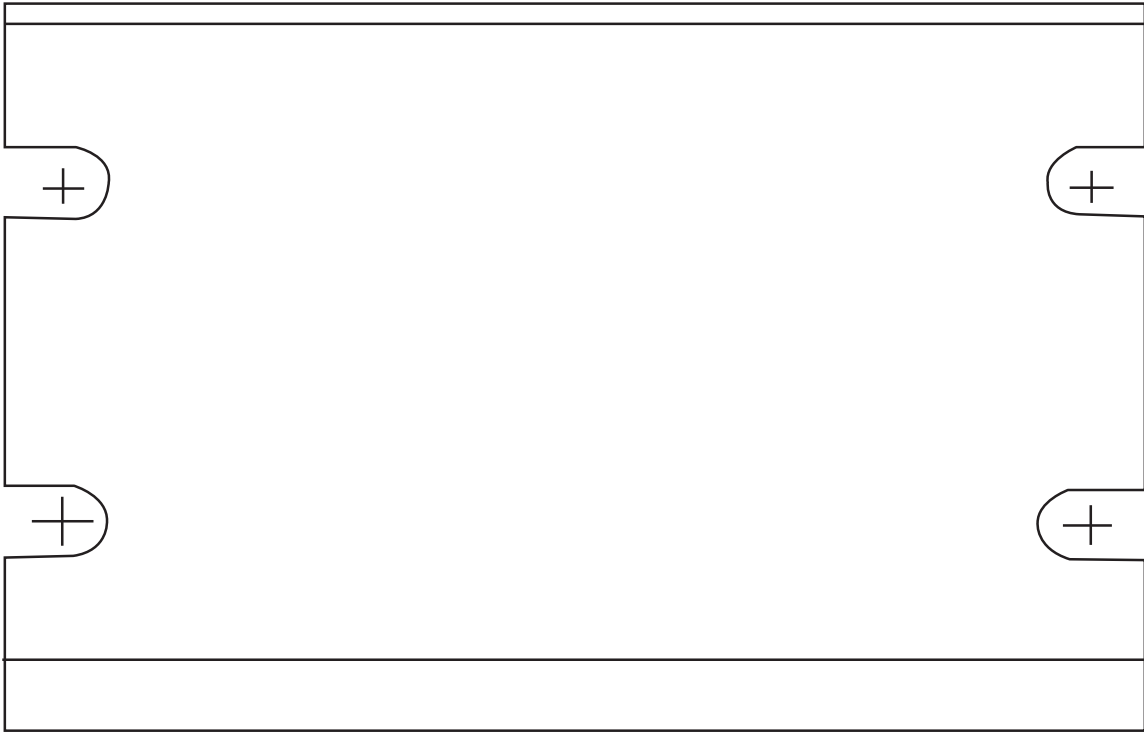

Figure 5



Mounting Template for CBC-450

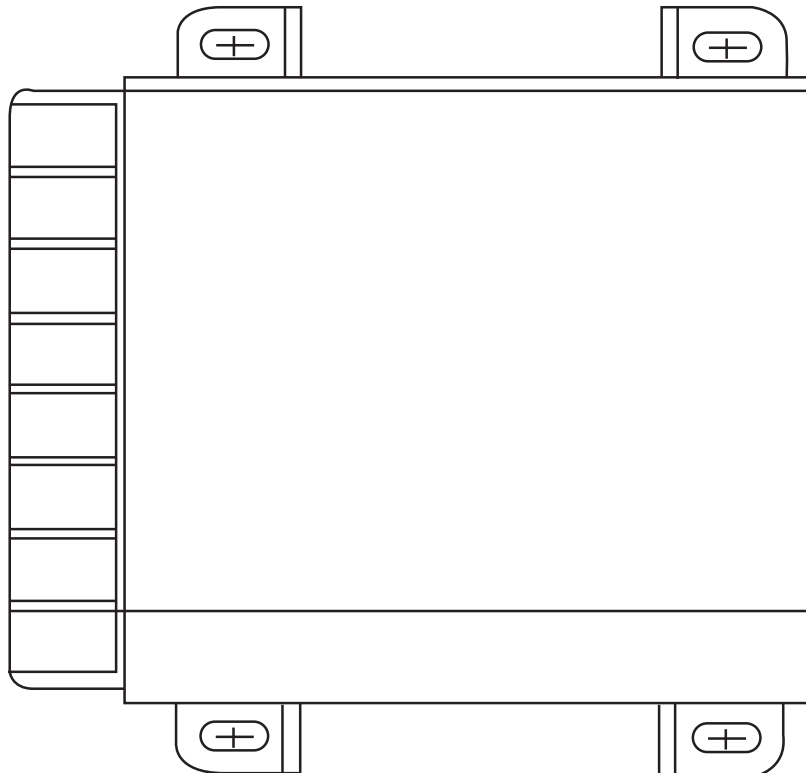

Figure 6



MEX (55) 53 63 23 31 MTY (81) 83 54 10 18
QRO (442) 1 95 72 60 ventas@industrialmagza.com



MEX (55) 53 63 23 31 MTY (81) 83 54 10 18
QRO (442) 1 95 72 60 ventas@industrialmagza.com

Warranty

Warner Electric LLC warrants that it will repair or replace (whichever it deems advisable) any product manufactured and sold by it which proves to be defective in material or workmanship within a period of one (1) year from the date of original purchase for consumer, commercial or industrial use.

This warranty extends only to the original purchaser and is not transferable or assignable without Warner Electric LLC's prior consent.

Warranty service can be obtained in the U.S.A. by returning any defective product, transportation charges prepaid, to the appropriate Warner Electric LLC factory. Additional warranty information may be obtained by writing the Customer Satisfaction Department, Warner Electric LLC, 449 Gardner Street, South Beloit, Illinois 61080, or by calling 815-389-3771.

A purchase receipt or other proof of original purchase will be required before warranty service is rendered. If found defective under the terms of this warranty, repair or replacement will be made, without charge, together with a refund for transportation costs. If found not to be defective, you will be notified and, with your consent, the item will be repaired or replaced and returned to you at your expense.

This warranty covers normal use and does not cover damage or defect which results from alteration, accident, neglect, or improper installation, operation, or maintenance.

Some states do not allow limitation on how long an implied warranty lasts, so the above limitation may not apply to you.

Warner Electric LLC's obligation under this warranty is limited to the repair or replacement of the defective product and in no event shall Warner Electric LLC be liable for consequential, indirect, or incidental damages of any kind incurred by reason of the manufacture, sale or use of any defective product. Warner Electric LLC neither assumes nor authorizes any other person to give any other warranty or to assume any other obligation or liability on its behalf.

WITH RESPECT TO CONSUMER USE OF THE PRODUCT, ANY IMPLIED WARRANTIES WHICH THE CONSUMER MAY HAVE ARE LIMITED IN DURATION TO ONE YEAR FROM THE DATE OF ORIGINAL CONSUMER PURCHASE. WITH RESPECT TO COMMERCIAL AND INDUSTRIAL USES OF THE PRODUCT, THE FOREGOING WARRANTY IS IN LIEU OF AND EXCLUDES ALL OTHER WARRANTIES, WHETHER EXPRESSED OR IMPLIED BY OPERATION OF LAW OR OTHERWISE, INCLUDING, BUT NOT LIMITED TO, ANY IMPLIED WARRANTIES OF MERCHANTABILITY OR FITNESS.

Some states do not allow the exclusion or limitation of incidental or consequential damages, so the above limitation or exclusion may not apply to you. This warranty gives you specific legal rights and you may also have other rights which vary from state to state.

Changes in Dimensions and Specifications

All dimensions and specifications shown in Warner Electric catalogs are subject to change without notice. Weights do not include weight of boxing for shipment. Certified prints will be furnished without charge on request to Warner Electric.



Warner Electric LLC
449 Gardner Street • South Beloit, IL 61080
815-389-3771 • Fax: 815-389-2582
www.warnerelectric.com
An Altra Industrial Motion Company