



GMR-SD Caliper Brakes for Dragline Applications



ALTRA INDUSTRIAL MOTION IS AT THE FOREFRONT OF LEADING POWER TRANSMISSION TECHNOLOGY PROVIDERS FOR HEAVY DUTY & OVERRUNNING CLUTCHES AND BRAKES

As a leading multinational designer and producer of advanced pneumatic, hydraulic and electromechanical power transmission solutions, Altra Industrial Motion has the technology and engineering capability to provide state-of-the-art drive and braking solutions.

Altra Industrial Motion's demonstrated expertise in the mining industry positions its multiple brands to meet the needs of this demanding marketplace.



- Extensive Application Experience
- Worldwide Customer Support
- Advanced Testing and Research
- State-of-the-Art Manufacturing Technology
- World Class Engineering

TWIFLEX GMR-SD CALIPER BRAKES PROVIDE RELIABLE, LONG-LASTING PERFORMANCE ON DRAGLINE APPLICATIONS

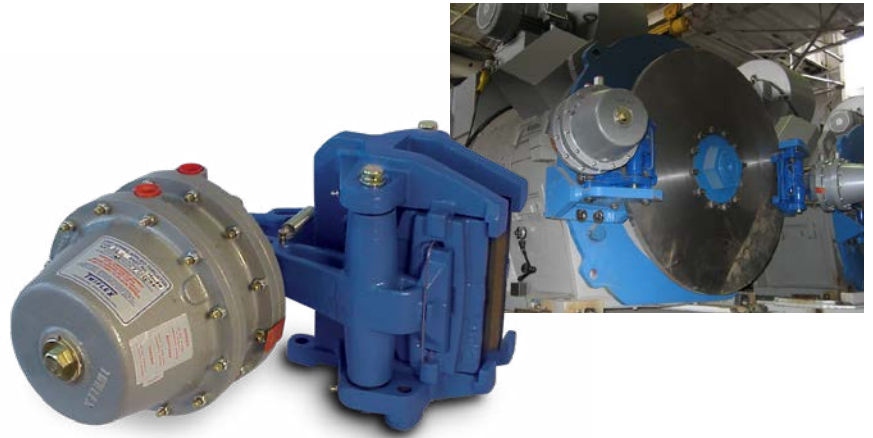

Now more than 25 years old, the Twiflex GMR-SD spring applied, air-released caliper brake is a recognized proven performer with over 8,000 units currently in service worldwide.

GMR-SD Brakes offer many advantages:

Modularity/Flexibility

Fit multiple units and vary size of thrusters to suit installation

Adjustable Torque

Torque adjusted according to operating conditions

Low Maintenance

Easy-to-replace brake pads, low cost spares

Easy Removal

Modularity allows for quick change out

Air Released

Spring applied, air released – both safe and reliable

WHY DO CUSTOMERS SELECT TWIFLEX BRAKES?



Problem: The dragline at a mine in Queensland, Australia recently required a comprehensive maintenance overhaul. Originally commissioned in 2008, the dragline's braking systems needed to be replaced after the extreme wear and tear of operating 24/7/365 for more than 4 years in the tough mine pit environment.

Solution: After a competitive review, Twiflex was selected to provide all required replacement brakes. To meet the machine's hoist and drag performance demands, Twiflex delivered spring applied, air-released GMR-SD 15.6 caliper brakes operating on 42" dia. discs that provided a combined braking force of 16186 lbf (72 kN) on each of 14 motors. GMR-SD 4.5 brakes operating on 40" dia. discs were used to supply 4721 lbf (21 kN) braking force on each of the 8 swing motors.

Models available up to 36 kN braking force

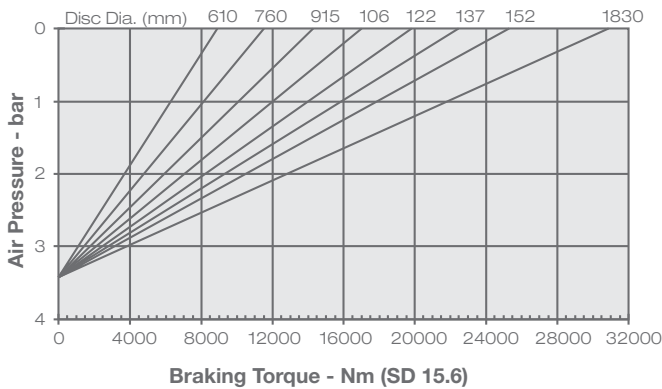

Thruster Type	Thruster Part No.	Thruster Weight (Kg)	Max. Braking Force (kN)	Retraction Air Pressure (bar)	Caliper Part No.	
					GMR	GMR40
SD4.5	7201265	17.7	10.5	1.4	6780971	6781006
SD8.4	7200924	18.2	19.5	2.4	6780971	6781006
SD11	7200811	19.2	25.0	3.3	6780971	6781006
SD12.9	7200810	20.0	30.0	3.8	6780971	6781006
SD15.6	7200778	21.0	36.0	4.6	6780971	6781006

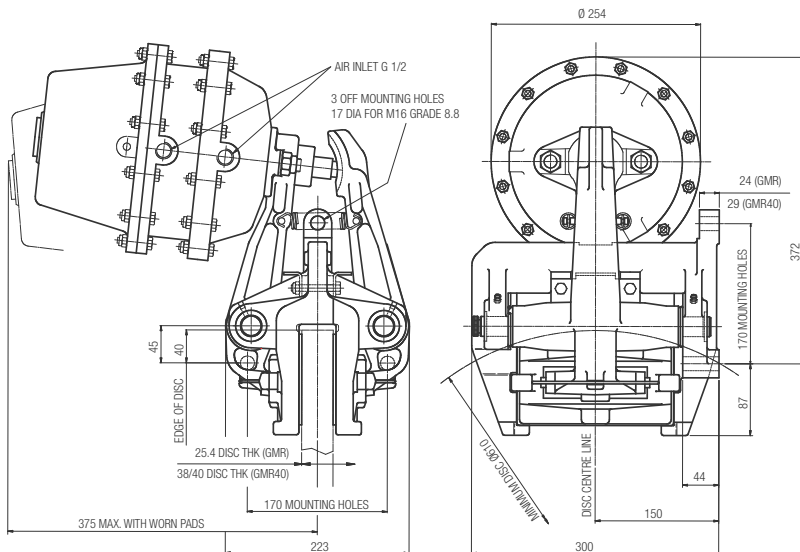

TWIFLEX IS A WELL KNOWN GLOBAL SUPPLIER OF DRAGLINE BRAKING SOLUTIONS

For more than 40 years, Twiflex has been providing dragline caliper (disc) brakes starting in the 1970's for Rapier 1000 and 2000 series machines.

More recently, Twiflex has supplied calipers for the following Marion (Caterpillar/Bucyrus) machines:

- Models 1370, 8050 and 8200 (drag and hoist)
- Model 8250 (drag, swing and propel)
- Model 8750 (swing and propel)
- Model 2750 (hoist drag)

On existing machines, Twiflex has been successful in replacing old shoe (drum) brakes and multi-disc friction brakes which are characterised by high wear rates under dynamic conditions and offer only limited adjustment.

Twiflex can provide comprehensive brake package solutions

Our wide product offering together with our extensive dragline application experience allows us to supply our customers with complete brake packages including:

- Brake calipers
- Thrusters
- Mounting frames
- Mounting bolts
- Discs, hubs and taper-lock bushings
- Air pressure regulators
- Local piping
- Guards

WHY DO CUSTOMERS SELECT TWIFLEX BRAKES ?



Twiflex recently provided GMR-SD caliper brakes for use on a new medium-duty 4,500 ton dragline at a mine in India. The brakes stop the dragline's load from moving as quickly as possible and bring it to rest in a controlled manner to avoid inducing torsional shock loads to the drivetrain and machine frame. The GMR-SD brakes are designed to handle the high energy associated with stopping these massive loads.

The GMR-SD caliper is Twiflex's most popular model for draglines and consists of a cast frame with two pivot-mounted arms which are actuated by a spring-applied, air-released thruster. Depending on the peak disc temperature calculated, the calipers can be fitted with either organic or sintered bronze pads which are suitable for emergency stops.

Twiflex Facilities

Europe

9 Briar Road, Twickenham
Middlesex TW2 6RB - England
+44 (0) 20 8894 1161
info@twiflex.com
sales@twiflex.com

Caliper Brakes and Thrusters

Amphill Road
Bedford, MK42 9RD - UK
+44 (0)1234 350311

Caliper Brakes and Thrusters

Hatschekstraße 36
69126 Heidelberg - Germany
+49 (0) 6221-30470

Caliper Brakes and Thrusters

North America

2800 Fisher Road
Wichita Falls, TX 76302 - USA
940-723-3483
Toll free: 844-723-3483
twiflex.info@twiflex.com

Caliper Brakes and Thrusters

The Brands of Altra Industrial Motion

Couplings

Ameridrives
www.ameridrives.com

Bibby Turboflex
www.bibbyturboflex.com

Guardian Couplings
www.guardiancouplings.com

Huco
www.huco.com

Lamiflex Couplings
www.lamiflexcouplings.com

Stromag
www.stromag.com

TB Wood's
www.tbwoods.com

G geared Cam Limit Switches

Stromag
www.stromag.com

Electric Clutches & Brakes

Inertia Dynamics
www.idicb.com

Matrix
www.matrix-international.com

Stromag
www.stromag.com

Warner Electric
www.warnerelectric.com

Linear Products

Warner Linear
www.warnerlinear.com

Engineered Bearing Assemblies

Kilian
www.kilianbearings.com

Heavy Duty Clutches & Brakes

Industrial Clutch
www.indclutch.com

Twiflex
www.twiflex.com

Stromag
www.stromag.com

Svendborg Brakes
www.svendborg-brakes.com

Wichita Clutch
www.wichitaclutch.com

Belted Drives

TB Wood's
www.tbwoods.com

Gearing

Bauer Gear Motor
www.bauergears.com

Boston Gear
www.bostongear.com

Delroyd Worm Gear
www.delroyd.com

Nuttall Gear
www.nuttallgear.com

Overrunning Clutches

Formsprag Clutch
www.formsprag.com

Marland Clutch
www.marland.com

Stieber Clutch
www.stieberclutch.com

Neither the accuracy nor completeness of the information contained in this publication is guaranteed by the company and may be subject to change in its sole discretion. The operating and performance characteristics of these products may vary depending on the application, installation, operating conditions and environmental factors. The company's terms and conditions of sale can be viewed at <http://www.altramotion.com/terms-and-conditions/sales-terms-and-conditions>. These terms and conditions apply to any person who may buy, acquire or use a product referred to herein, including any person who buys from a licensed distributor of these branded products.

©2017 by Twiflex LLC. All rights reserved. All trademarks in this publication are the sole and exclusive property of Twiflex LLC or one of its affiliated companies.